

## Description

The AL5810Q is an Automotive AEC-Q100 Linear LED Driver offering an excellent temperature and voltage current stability with output adjustable handling capability. The AL5810Q simplifies the design of LED drivers by setting the LED current with an external resistor using standard value resistors.

The AL5810Q has an open drain output that can swing from 2.0V up to 60V supply voltage enabling it drive long LED chains for high side or low side LED strings. Its low 0.5V  $R_{SET}$  pin is outside of the LED current path and can maintain current accuracy while minimizing the required overheads to regulate the LED current. This reduces its power dissipation when compared to traditional linear LED drivers. It makes it ideal for driving LEDs up to 200mA.

The AL5810Q is available in the Wettable Flank W-DFN2020-3/SWP (Type A) package (2mm x 2mm), power dissipation ( $P_D$ ) up to 2W. The AL5810Q has been qualified to AEC-Q100 Grade 2 with Automotive Compliant supporting PPAPs available.

## Features

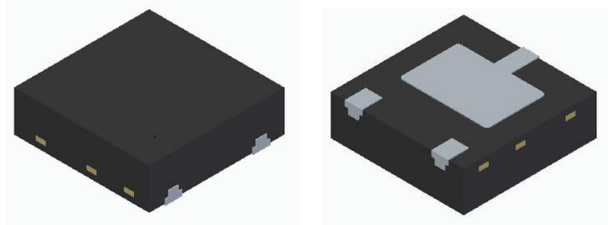
- ACE-Q100 Grade 2 Qualified
- 2.0V to 60V Wide Input Voltage Range
- Low Reference Voltage ( $V_{RSET} = 0.5V$ )
- Adjustable Sink or Source LED Current Up to 200mA
- $\pm 5\%$  LED Current Tolerance @Room Temperature
- Parallel Devices to Increase Regulated Current
- Over Temperature Shutdown
- $-40^{\circ}C$  to  $+105^{\circ}C$  Ambient Temperature Range
- Wettable W-DFN2020-3/SWP (Type A) (2mm x 2mm)  $P_D$  up to 2W
- **Totally Lead-Free & Fully RoHS Compliant (Notes 1 & 2)**
- **Halogen and Antimony Free. "Green" Device (Note 3)**
- **The AL5810Q is suitable for automotive applications requiring specific change control; this part is AEC-Q100 qualified, PPAP capable, and manufactured in IATF 16949 certified facilities.**

<https://www.diodes.com/quality/product-definitions/>

- Notes:
1. No purposely added lead. Fully EU Directive 2002/95/EC (RoHS), 2011/65/EU (RoHS 2) & 2015/863/EU (RoHS 3) compliant.
  2. See <https://www.diodes.com/quality/lead-free/> for more information about Diodes Incorporated's definitions of Halogen- and Antimony-free, "Green" and Lead-free.
  3. Halogen- and Antimony-free "Green" products are defined as those which contain <900ppm bromine, <900ppm chlorine (<1500ppm total Br + Cl) and <1000ppm antimony compounds.

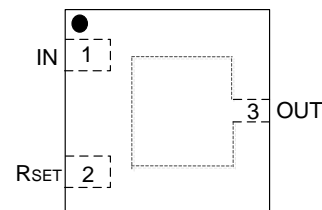
## Pin Assignments

### W-DFN2020-3/SWP (Type A)



(Top View)

(Bottom View)



(Top View)

## Applications

- Interior and Exterior Automotive LED Lighting
- Puddle Lighting
- Side Marker Lights
- Automotive Mirror Turning Lights
- LED Strings for Dome and Mood Lighting
- Instrumentation Illumination

**Typical Applications Circuit**

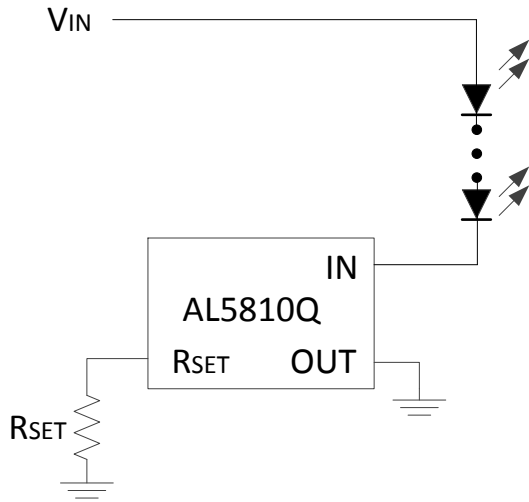


Figure 1. Low Side LED String Configuration

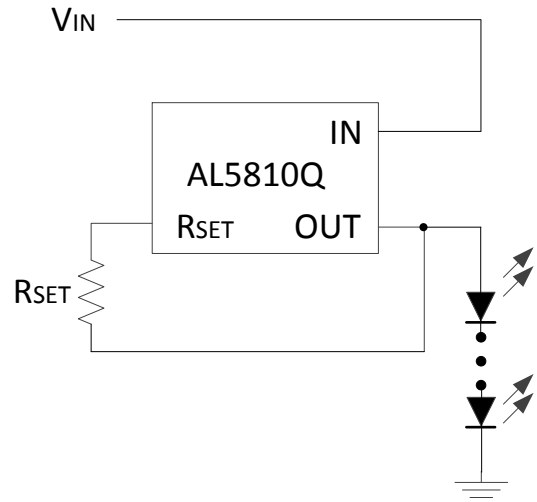


Figure 2. High Side LED String Configuration

**Pin Descriptions**

Pin Name	Pin Number	Function
IN	1	LED Current Input Terminal. Current flows <b>IN</b> to this pin. For low-side LED string application, connect the LED cathode terminal to the "IN" terminal. For high-side LED string application, connect the LED anode terminal to the "OUT" terminal.
RSET	2	LED Current Setting Pin. Connect a resistor from this pin to GND: $I_{LED} = 750/R_{SET}$
OUT	3	LED Current Output Terminal. Current flows <b>OUT</b> of this pin. For low-side LED string application, connect the LED cathode terminal to the "IN" terminal. For high-side LED string application, connect the LED anode terminal to the "OUT" terminal.

## Functional Block Diagram

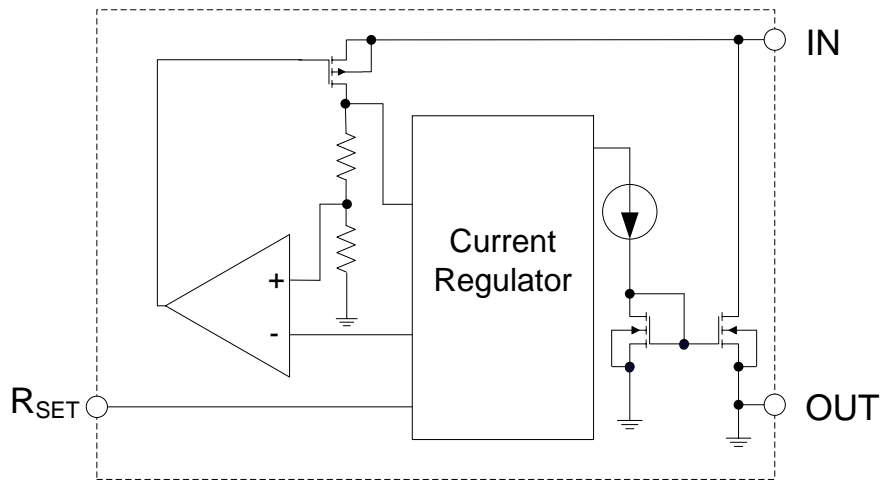


Figure 3. Functional Block Diagram

## Absolute Maximum Ratings (Note 4) (@T<sub>A</sub> = +25°C, unless otherwise specified.)

Symbol	Parameter	Rating	Unit
V <sub>IN_OUT</sub>	IN Pin Voltage Relative to OUT Pin	-0.3 to +66	V
V <sub>RSET</sub>	RSET Pin Voltage Relative to OUT Pin	-0.3 to +6	V
I <sub>IN_OUT</sub>	LED Current from "IN" to "OUT"	220	mA
ESD HBM	Human Body Model ESD Protection (Note 5)	4,000	V
ESD CDM	Charged Device Model ESD Protection (Note 5)	1,000	V
T <sub>J</sub>	Operating Junction Temperature	-40 to +150	°C
T <sub>STG</sub>	Storage Temperature	-55 to +150	°C

- Notes:
- Stresses greater than the *Absolute Maximum Ratings* specified above can cause permanent damage to the device. These are stress ratings only; functional operation of the device at these or any other conditions exceeding those indicated in this specification is not implied. Device reliability can be affected by exposure to absolute maximum rating conditions for extended periods of time.
  - Semiconductor devices are ESD sensitive and can be damaged by exposure to ESD events. Suitable ESD precautions should be taken when handling and transporting these devices.

## Package Thermal Data

Symbol	Parameter	Rating	Unit
θ <sub>JC</sub>	Thermal Resistance Junction-to-Case (Note 6)	10.76	°C/W
θ <sub>JA</sub>	Thermal Resistance Junction-to-Ambient (Note 6)	61.66	°C/W
P <sub>D</sub>	Power Dissipation T <sub>A</sub> = +25°C, T <sub>J</sub> = +150°C (Note 7)	2	W

- Notes:
- Test condition: Device mounted on FR-4 PCB (51mm x 51mm 2oz copper, minimum recommended pad layout on top layer and thermal vias to bottom layer with maximum area ground plane. For better thermal performance, larger copper pad for heat-sink is needed.
  - Dominant conduction path via exposed pad.

**Recommended Operating Conditions** (@T<sub>A</sub> = +25°C, unless otherwise specified.)

Symbol	Parameter	Min	Max	Unit
V <sub>IN_OUT</sub>	"IN" Voltage Range Relative to "OUT" Pin (Note 10)	2.5	60	V
I <sub>IN_OUT</sub>	LED Current (Notes 8 & 9)	1	200	mA
t <sub>PWM(ON)</sub>	PWM Pulse Width in Dimming Mode On-Time	100	—	μs
T <sub>J</sub>	Operating Junction Temperature Range (Note 11)	-40	+150	°C
T <sub>A</sub>	Operating Ambient Temperature Range AEC-Q100 Grade 2 (Note 9)	-40	+105	°C

**Electrical Characteristics** (@T<sub>A</sub> = +25°C, V<sub>IN\_OUT</sub> = 3.5V (Note 10), R<sub>SET</sub> = 7.5kΩ, unless otherwise specified.)

Symbol	Parameter	Conditions		Min	Typ	Max	Unit
V <sub>IN_OUT</sub>	In-Out Supply Voltage	I <sub>OUT</sub> ≥ 100mA (Note 12)	T <sub>A</sub> = -40°C to +105°C	2.5	—	60	V
		I <sub>OUT</sub> < 100mA (Note 12)		2.0	—	60	V
V <sub>RSET</sub>	R <sub>SET</sub> Voltage	—	T <sub>A</sub> = -40°C to +105°C	—	0.5	—	V
I <sub>IN_OUT</sub>	I <sub>IN_OUT</sub> Current Accuracy	R <sub>SET</sub> = 3.75kΩ	T <sub>A</sub> = +25°C	186	200	222	mA
		R <sub>SET</sub> = 5kΩ		141	150	163	
		R <sub>SET</sub> = 7.5kΩ		95	100	105	
		R <sub>SET</sub> = 7.5kΩ	T <sub>A</sub> = -40°C to +105°C	92	100	108	
		R <sub>SET</sub> = 15kΩ		43	50	56	
		R <sub>SET</sub> = 75kΩ		6	10	14	
R <sub>SET</sub> = 150kΩ	3	5	7				
I <sub>TEMCO</sub>	Temperature Coefficient of Current Accuracy	I <sub>OUT</sub> = 100mA	T <sub>A</sub> = -40°C to +105°C	—	1	—	%
I <sub>LINE</sub>	I <sub>IN_OUT</sub> Current Line Regulation	V <sub>IN</sub> = 3.5V to 60V (Note 11)	T <sub>A</sub> = +25°C	—	4	—	%
I <sub>CC</sub>	IN Pin Operating Current	V <sub>IN</sub> = 60V R <sub>SET</sub> = 1mΩ	T <sub>A</sub> = -40°C to +105°C	300	685	1000	μA
V <sub>MIN</sub>	Minimum Power Up Voltage	Increase V <sub>IN_OUT</sub> (Note 13)	T <sub>A</sub> = -40°C to +105°C	1	1.5	2	V
t <sub>ON_MIN</sub>	Minimum On Pulse Width for PWM Dimming	PWM Dimming with External MOSFET Connected to R <sub>SET</sub> , See PWM Dimming Section. (Notes 14 & 15)	—	100	—	—	μs
t <sub>OFF_MIN</sub>	Minimum Off Pulse Width for PWM Dimming	PWM Dimming with External MOSFET Connected to R <sub>SET</sub> , See PWM Dimming Section. (Notes 14 & 15)	—	—	—	10	μs
T <sub>SHDN</sub>	Thermal Shutdown	Junction Temperature (Note 16)	—	—	165	—	°C
T <sub>HYS</sub>	Thermal Shutdown Hysteresis	—	—	—	30	—	°C

- Notes:
- For improved accuracy LED current should be greater than 60mA.
  - Maximum LED current is also limited by ambient temperature and power dissipation such that junction temperature should be kept less than or equal to +150°C.
  - All voltages unless otherwise stated are measured with respect to OUT pin.
  - Measured by the percentage degree of LED current variation when V<sub>IN\_OUT</sub> varies from 3.5V to 60V each current option.
  - Subject to maximum junction temperature of +150°C not being exceeded. The Maximum ambient temperature range is limited by device power dissipation; such that its junction temperature should be kept less than or equal to +150°C. See Page 3 for more information on power dissipation. Devices have been qualified to AEC-Q100 Grade 2.
  - Apply the power linearly to the chip until the device starts to turn on.
  - t<sub>ON\_MIN</sub> time includes the delay and the rise time needed for I<sub>OUT</sub> to reach 90% of its final value. t<sub>OFF\_MIN</sub> time is the time needed for I<sub>OUT</sub> to drop below 10% of its final value.
  - This parameter only guaranteed by design, not tested in production.
  - Ambient temperature at which OTP is triggered may vary depending on application, PCB layout and material used.

**Typical Performance Characteristics – (100mA, 150mA, 200mA Settings)**

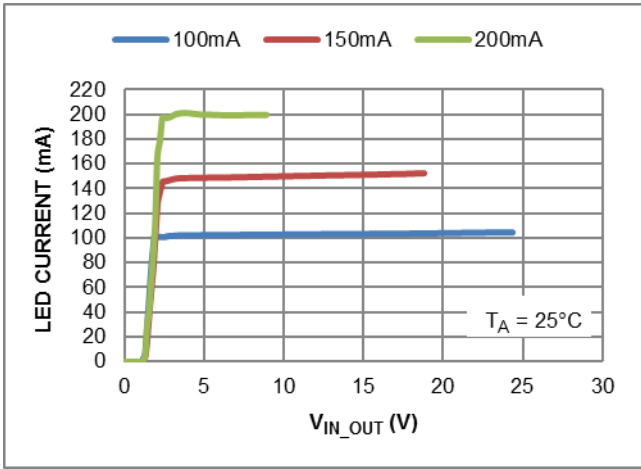


Figure 4. LED Current vs. V<sub>IN\_OUT</sub>

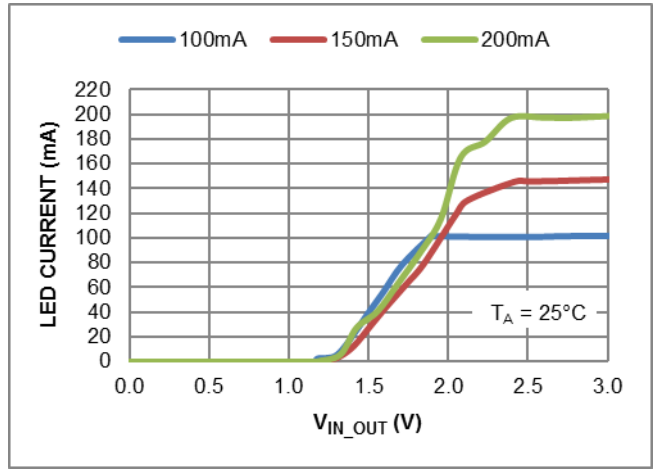


Figure 5. Startup Minimum Operating Voltage

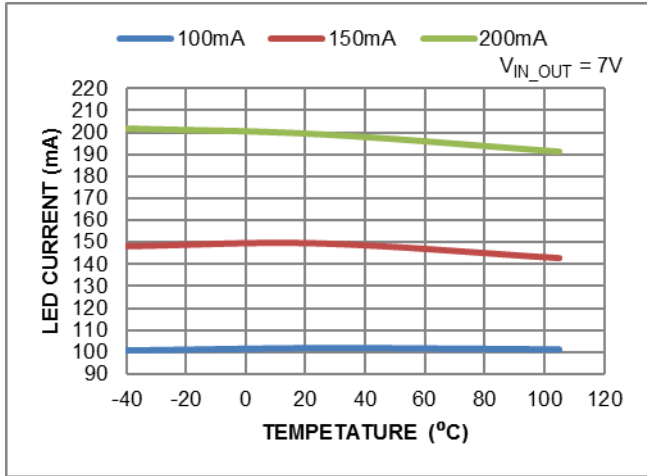


Figure 6. LED Current vs. Ambient Temperature

**Application Information**

**Description**

The AL5810Q is a linear LED driver and regulates the LED current by sinking current to the IN pin. The AL5810Q can support up to 200mA LED current, with ±5% accuracy @+25°C. The LED current is set by an external resistor, R<sub>SET</sub>, connected from the R<sub>SET</sub> pin to GND. This resistor supplies the bias current of the AL5810Q together with current regulator to set the LED current.

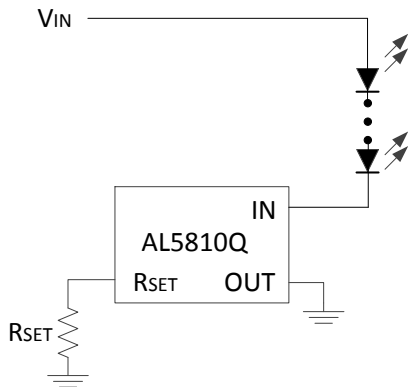
The LED current is determined by this equation:

$$I_{LED} = 1500 * \frac{0.5}{R_{SET}} \quad \text{where 1500 is the current ratio between the LED pin current and RSET pin current.}$$

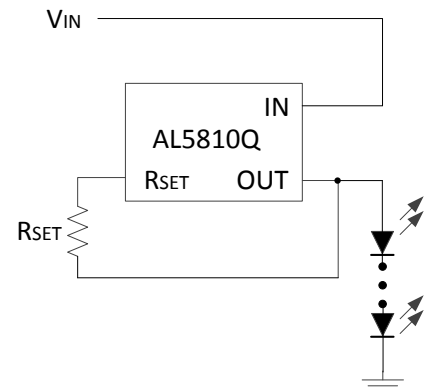
With R<sub>SET</sub> = 15k

$$I_{LED} = 1500 * \frac{0.5}{15k} = 50mA$$

The AL5810Q, with its 60V capability on the IN pin, allows operation from supply rails up to 60V and/or directly drive LED chains up to 60V as shown in Figures 7 and 8.

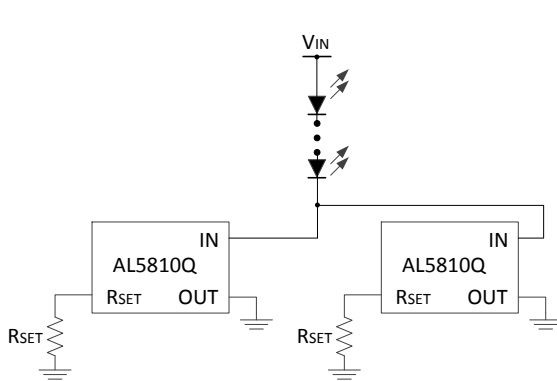


**Figure 7. Low Side LED String Setting**

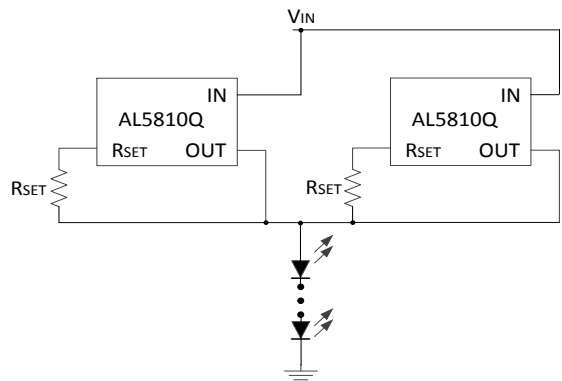


**Figure 8. High Side Current LED String**

The LED current can be increased by connecting two or more the AL5810Q in parallel shown in Figure 9.



**(a) Low-Side Configuration**



**(b) High-Side Configuration**

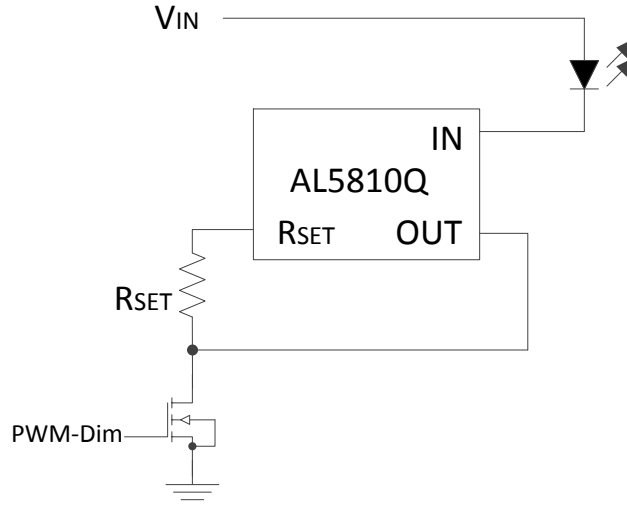
**Figure 9. Higher LED Current by Parallel Configuration of AL5810Q**

**Application Information** (continued)

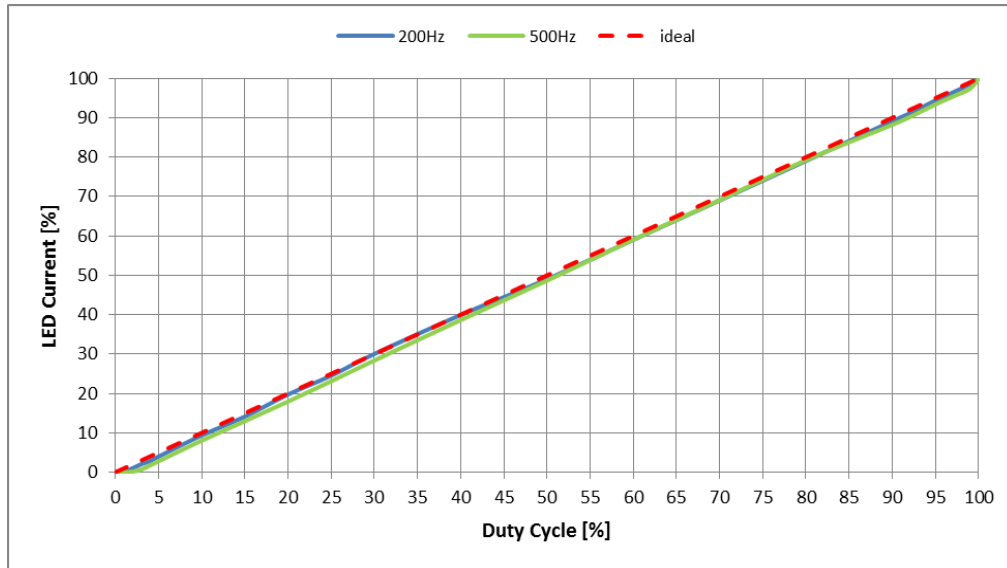
**PWM Dimming**

The AL5810Q can be used to provide LED current dimming driving the R<sub>SET</sub> pin via the current setting resistor (R<sub>SET</sub>) and a series MOSFET switch to ground (Figure 10). The R<sub>SET</sub> pin current is then effectively switched on and off causing the LED current to turn on and off. The linearity is shown in Figure 11.

Test conditions: V<sub>IN</sub> = 6V, 1LED low side configuration, R<sub>SET</sub> = 7.5kΩ, I<sub>LED</sub> = 100mA, N-Channel MOSFET (P/N: ZXMN6A11Z), PWM frequency 200Hz to 500Hz Square wave, 0V to 4V gate voltage.



**Figure 10. PWM Dimming by External MOSFET**



**Figure 11. PWM Dimming Linearity**

**Application Information** (continued)

**Recommended PWM Frequency and Dimming Range**

PWM Frequency (Hz)	Duty Cycle (%)	
	Min	Max
200	2	99.8
500	5	99.5

Use the following formula to calculate the Min and Max duty cycle:

Min. Duty cycle (%) = (t<sub>ON\_MIN</sub>) / (time period of the PWM signal)  
 Max. Duty cycle (%) = 100% - ((t<sub>OFF\_MIN</sub>) / (time period of the PWM signal))

Note: t<sub>ON\_MIN</sub> = 0.1ms (Min. value), and t<sub>OFF\_MIN</sub> = 0.01ms (Min. value) are listed in the Electrical Characteristics table on page 4.

**Thermal Considerations**

When designing linear LED driver's careful consideration must be given to the power dissipation within the LED driver and PCB layout / heat sinking. A Linear LED driver has to be able to handle the large potential input voltage variations due to the supply voltage tolerance and also the variation in LED forward voltage due to binning and temperature. This can cause a large potential difference across the LED driver resulting in a larger power dissipation than anticipated.

In automotive applications when the engine is running, the typical input voltage range varies from 13.5V to 14.7V.

The recommended minimum V<sub>IN\_OUT</sub> voltage of 2.5V enables the AL5810Q to drive 2 LED in series from the 12V battery voltage (assuming V<sub>LED</sub> < 3.25V).

The AL5810Q's power dissipation under these conditions will be:

$$V_{IN\_OUT} * I_{LED} = 2.5 * I_{LED}$$

So for the 100mA AL5810Q under these conditions this equals:

$$2.5V * 100mA = 250mW$$

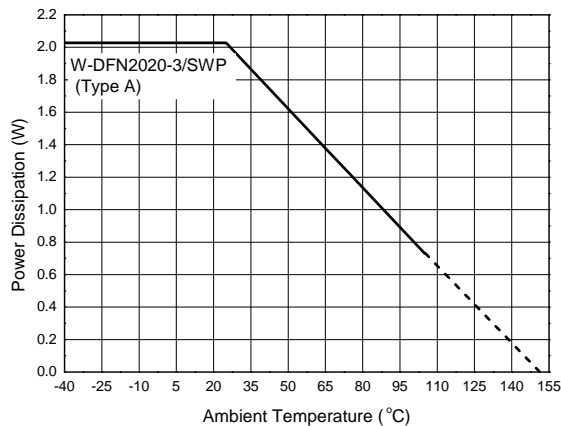
Under maximum input conditions (14.7V), V<sub>IN\_OUT</sub> = 14.7V to 6.5V (2 LEDs Voltage) the AL5810Q's power dissipation will be:

$$V_{IN\_OUT} * I_{LED} = 8.2 * I_{LED}$$

So for the 100mA AL5810Q this equals:

$$8.2V * 100mA = 820mW$$

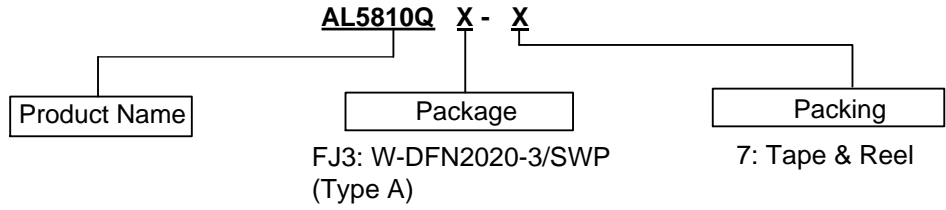
Figure 12 shows the AL5810Q's power dissipation capability, which varies with PCB size and area of metal associated with the ground plane used for heat sinking. By increasing the area on the top layer, the thermal impedance could be improved.



**Figure 12. Power Dissipation Derating**



**Ordering Information**

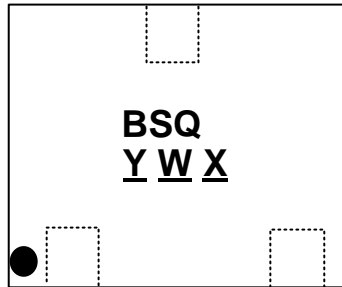


Part Number	Package Code	Packaging	Tape and Reel	
			Quantity	Part Number Suffix
AL5810QFJ3-7	FJ3	W-DFN2020-3 /SWP(Type A)	3,000/Tape & Reel	-7

**Marking Information**

**W-DFN2020-3 /SWP (Type A)**

**( Top View )**

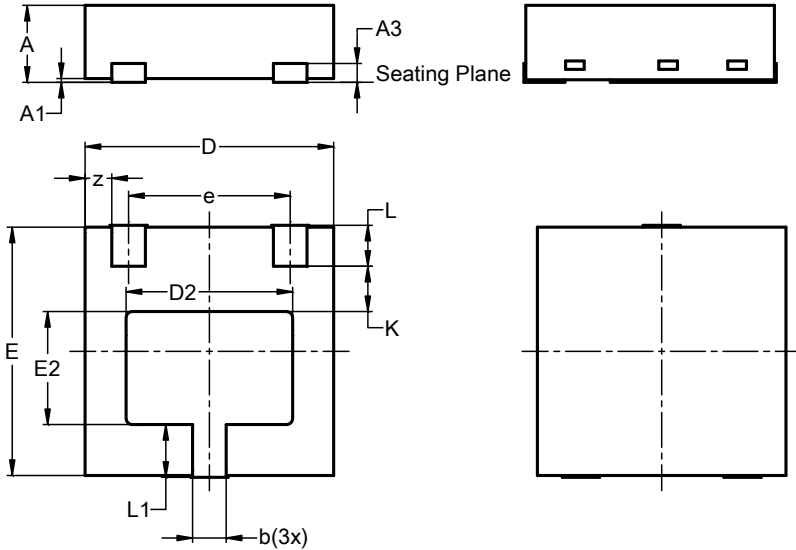


BSQ : Identification Code  
 Y : Year: 0 to 9  
 W : Week: A to Z: 1 to 26 Week;  
       a to z; 27 to 52 Week; z Represents  
       52 and 53 Week  
 X : Internal Code

**Package Outline Dimensions**

Please see <http://www.diodes.com/package-outlines.html> for the latest version.

W-DFN2020-3/SWP (Type A)

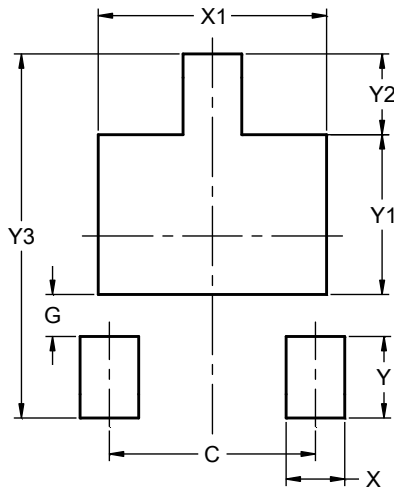


W-DFN2020-3 /SWP (Type A)			
Dim	Min	Max	Typ
A	0.57	0.67	0.62
A1	0.00	0.05	0.03
A3	—	—	0.152
b	0.22	0.32	0.27
D	1.95	2.05	2.00
D2	1.24	1.44	1.34
D4	0.56	0.76	0.66
E	1.95	2.05	2.00
E2	0.81	1.01	0.91
e	—	—	1.30
k	—	—	0.365
L	0.28	0.38	0.33
L1	0.375	0.475	0.425
z	—	—	0.215
All Dimensions in mm			

**Suggested Pad Layout**

Please see <http://www.diodes.com/package-outlines.html> for the latest version.

W-DFN2020-3/SWP (Type A)



Dimensions	Value (in mm)
C	1.300
G	0.265
X	0.370
X1	1.440
Y	0.515
Y1	1.010
Y2	0.510
Y3	2.300

**Mechanical Data**

- Moisture Sensitivity: MSL Level 1 per J-STD-020
- Terminals: Finish - Matte Tin Plated Leads, Solderable per JESD22-B102 (Ⓔ)
- Weight: 0.0071 grams (Approximate)

**IMPORTANT NOTICE**

1. DIODES INCORPORATED AND ITS SUBSIDIARIES (“DIODES”) MAKE NO WARRANTY OF ANY KIND, EXPRESS OR IMPLIED, WITH REGARDS TO ANY INFORMATION CONTAINED IN THIS DOCUMENT, INCLUDING, BUT NOT LIMITED TO, THE IMPLIED WARRANTIES OF MERCHANTABILITY, FITNESS FOR A PARTICULAR PURPOSE OR NON-INFRINGEMENT OF THIRD PARTY INTELLECTUAL PROPERTY RIGHTS (AND THEIR EQUIVALENTS UNDER THE LAWS OF ANY JURISDICTION).
2. The Information contained herein is for informational purpose only and is provided only to illustrate the operation of Diodes products described herein and application examples. Diodes does not assume any liability arising out of the application or use of this document or any product described herein. This document is intended for skilled and technically trained engineering customers and users who design with Diodes products. Diodes products may be used to facilitate safety-related applications; however, in all instances customers and users are responsible for (a) selecting the appropriate Diodes products for their applications, (b) evaluating the suitability of the Diodes products for their intended applications, (c) ensuring their applications, which incorporate Diodes products, comply the applicable legal and regulatory requirements as well as safety and functional-safety related standards, and (d) ensuring they design with appropriate safeguards (including testing, validation, quality control techniques, redundancy, malfunction prevention, and appropriate treatment for aging degradation) to minimize the risks associated with their applications.
3. Diodes assumes no liability for any application-related information, support, assistance or feedback that may be provided by Diodes from time to time. Any customer or user of this document or products described herein will assume all risks and liabilities associated with such use, and will hold Diodes and all companies whose products are represented herein or on Diodes’ websites, harmless against all damages and liabilities.
4. Products described herein may be covered by one or more United States, international or foreign patents and pending patent applications. Product names and markings noted herein may also be covered by one or more United States, international or foreign trademarks and trademark applications. Diodes does not convey any license under any of its intellectual property rights or the rights of any third parties (including third parties whose products and services may be described in this document or on Diodes’ website) under this document.
5. Diodes products are provided subject to Diodes’ Standard Terms and Conditions of Sale (<https://www.diodes.com/about/company/terms-and-conditions/terms-and-conditions-of-sales/>) or other applicable terms. This document does not alter or expand the applicable warranties provided by Diodes. Diodes does not warrant or accept any liability whatsoever in respect of any products purchased through unauthorized sales channel.
6. Diodes products and technology may not be used for or incorporated into any products or systems whose manufacture, use or sale is prohibited under any applicable laws and regulations. Should customers or users use Diodes products in contravention of any applicable laws or regulations, or for any unintended or unauthorized application, customers and users will (a) be solely responsible for any damages, losses or penalties arising in connection therewith or as a result thereof, and (b) indemnify and hold Diodes and its representatives and agents harmless against any and all claims, damages, expenses, and attorney fees arising out of, directly or indirectly, any claim relating to any noncompliance with the applicable laws and regulations, as well as any unintended or unauthorized application.
7. While efforts have been made to ensure the information contained in this document is accurate, complete and current, it may contain technical inaccuracies, omissions and typographical errors. Diodes does not warrant that information contained in this document is error-free and Diodes is under no obligation to update or otherwise correct this information. Notwithstanding the foregoing, Diodes reserves the right to make modifications, enhancements, improvements, corrections or other changes without further notice to this document and any product described herein. This document is written in English but may be translated into multiple languages for reference. Only the English version of this document is the final and determinative format released by Diodes.
8. Any unauthorized copying, modification, distribution, transmission, display or other use of this document (or any portion hereof) is prohibited. Diodes assumes no responsibility for any losses incurred by the customers or users or any third parties arising from any such unauthorized use.

Copyright © 2020 Diodes Incorporated

[www.diodes.com](http://www.diodes.com)