

DATE	ECO NO	DESCRIPTION	BY

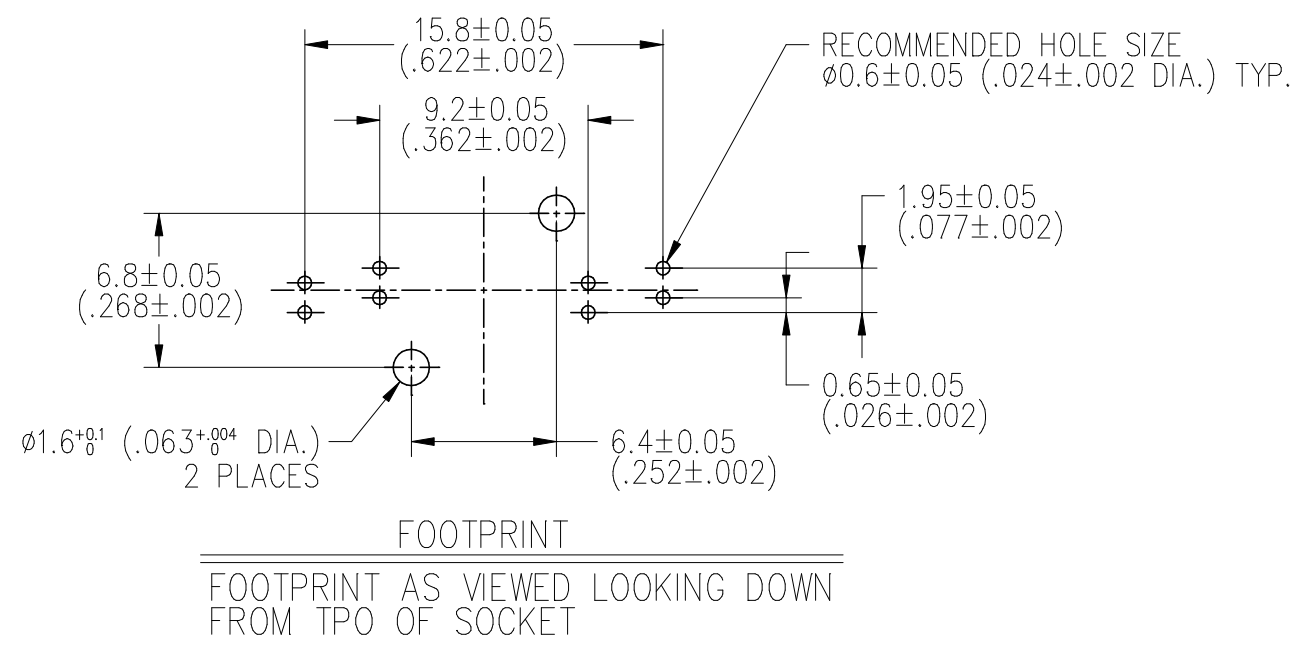
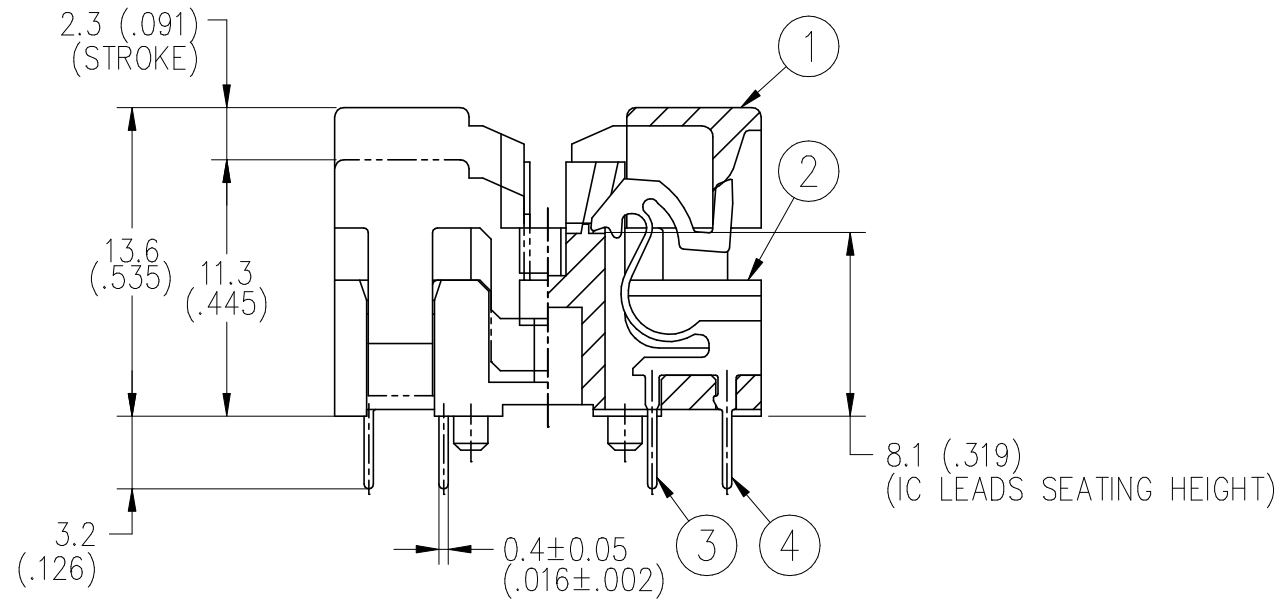
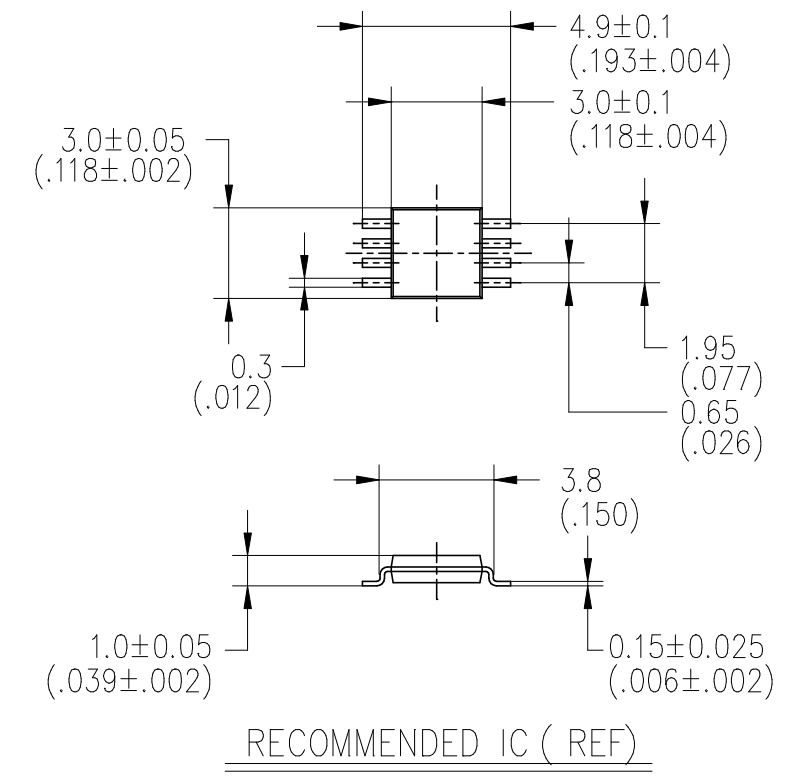
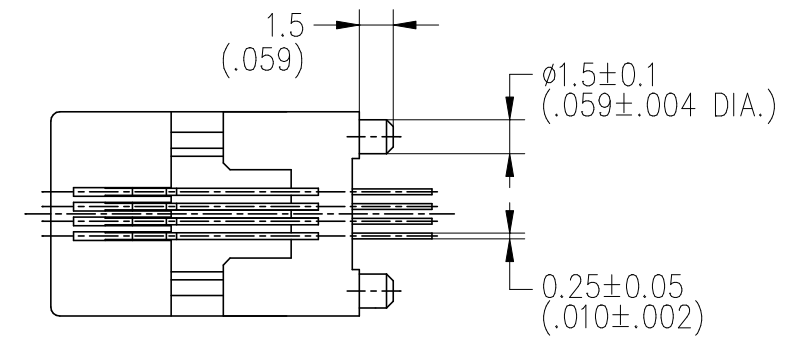
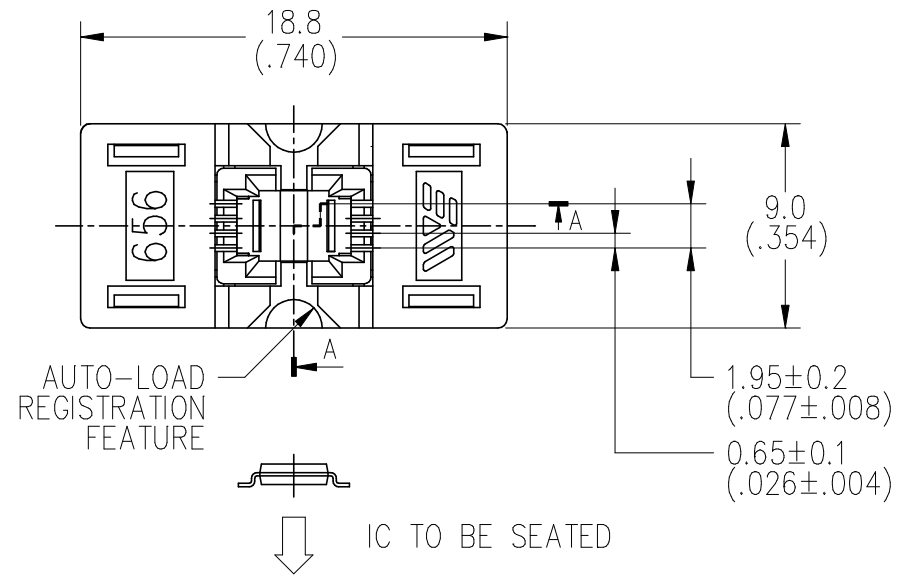

Performance.

1. Insulation Resistance : 1000 M Ω min. at 500V.D.C
2. Dielectric Withstanding Voltage : 600 V.A.C (RMS)
3. Contact Resistance : 30 m Ω max. at 20mV max.
4. Temperature Range : -40°C ~ +150°C

④	CONTACT-(2)	Be Cu	4	PLATING : Au
③	CONTACT-(1)	Be Cu	4	PLATING : Au
②	BASE-8P	PEI	1	COLOR : BLACK
①	COVER-8P	PEI	1	COLOR : BLACK
P.NO	PART DESCRIPTION	MATERIAL	QTY	NOTE
GENERAL TOLERANCES				
±0.3 (±.012)				
UNIT	SCALE	ANGLE	TITLE	
mm (in.)	3/1	3rd.	SSOP 8P SOCKET	
DRAWN	/ /	DWG NO.		
CHECKED	/ /	656-1082211		
APPROVED	/ /			

