

# Wheeled Laptop and Projector Floor Stand

**multicomp** PRO



## Description

A portable, floor standing platform with castors for complete mobility. Ideal to hold a notebook computer or projector for office, school or conference use.

## Features

- Tilting platform with cushioned safety sides
- Robust steel construction with plastic adjustment collars
- Folding tripod base with lockable castors
- Platform dimensions: 400mm × 300mm
- Adjustable working height: 1110mm to 1500mm
- Folded dimensions (W × H × D): 350mm × 970mm × 125mm
- 15kg Capacity

1. Invert the lower upright and place the wheeled foot assembly on the end.
2. Insert the locking bolt with washer and tighten with the hex key.
3. Rotate the individual feet so they are spaced evenly and lock into place.
4. Turn the upright over and stand it on its wheels. Insert the upper upright into the lower assembly and tighten the thumb wheel to set the height as required.
6. Remove the bolt and thumb wheel from the adjuster quadrant.
7. Lower the table assembly over the adjuster so the adjustment slots align with the cross tube.
8. Insert the bolt through the slots and fit the thumb wheel.
9. Adjust the angle of the table as required and fully tighten the thumb wheel.

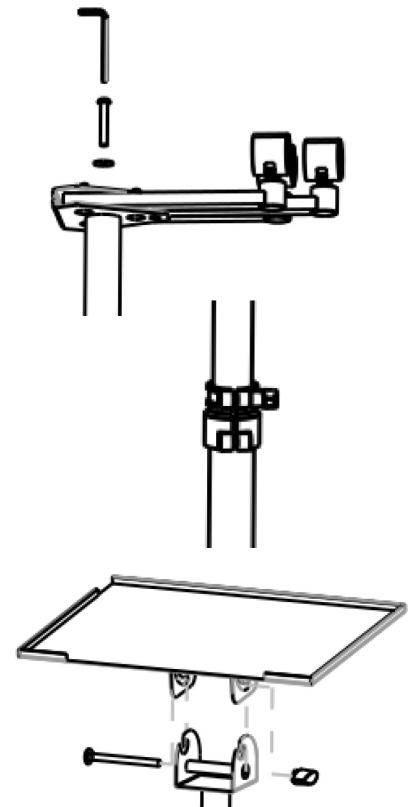

## Part Number Table

Description	Part Number
Wheeled Laptop and Projector Floor Stand, Black, 15kg Capacity	PLS00593

**Important Notice :** This data sheet and its contents (the "Information") belong to the members of the AVNET group of companies (the "Group") or are licensed to it. No licence is granted for the use of it other than for information purposes in connection with the products to which it relates. No licence of any intellectual property rights is granted. The Information is subject to change without notice and replaces all data sheets previously supplied. The Information supplied is believed to be accurate but the Group assumes no responsibility for its accuracy or completeness, any error in or omission from it or for any use made of it. Users of this data sheet should check for themselves the Information and the suitability of the products for their purpose and not make any assumptions based on information included or omitted. Liability for loss or damage resulting from any reliance on the Information or use of it (including liability resulting from negligence or where the Group was aware of the possibility of such loss or damage arising) is excluded. This will not operate to limit or restrict the Group's liability for death or personal injury resulting from its negligence. Multicomp Pro is the registered trademark of Premier Farnell Limited 2019.

Newark.com/multicomp-pro  
Farnell.com/multicomp-pro  
Element14.com/multicomp-pro

**multicomp** PRO