

CE

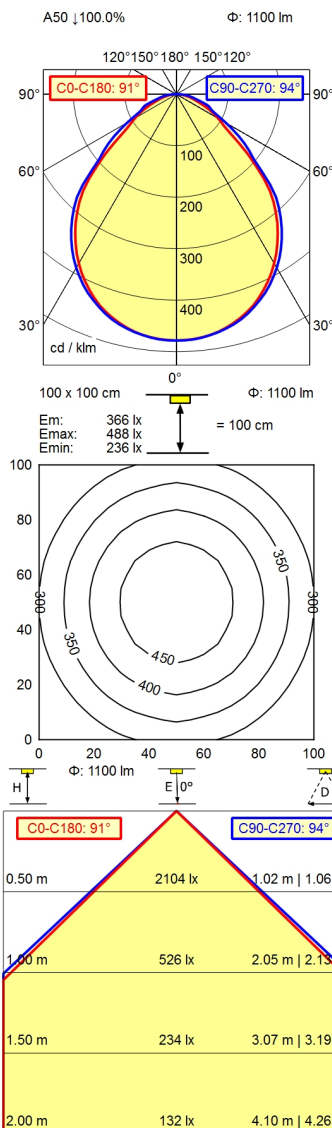

CEE 7/XVII



light source
work equipment
connected load
power consumption
luminous flux
light distribution
direct ratio
beam angle
colour temperature
colour temperatur
color rendering index (CRI)
glare control
luminance (L65)
unified glare rating (4H 8H)
system of protection
class of protection
technology
operation
housing
cover
weight (net)
mains lead
design
fastening
dimensions
special features

LED
electronic ballast
220-240V, 50/60Hz
env. 15 W
approx. 1.100 lm
direct
approx. 100 %
92°
neutral white
approx. 5.000 K
>= 80
structured screen
<= 13000 cd/m²
<= 25
20
I
switchable
rocker switch
aluminium/plastic; anodised; aluminium coloured
anodised
structured screen
env. 1,6 kg
approx. 3,0 m; mains plug; CEE 7/XVII
mounted version
screw down lash
449,00000 mm; 120,00000 mm; 40,00000 mm
mounting right