

STPOWER MOSFETs in the innovative TO-LL



The latest evolution in SMD power packages



The new space-saving and thermally efficient leadless package

The new STPOWER MOSFET Super-junction MDmesh™(*) M6 and MDmesh DM6 series in the space-saving and thermally efficient TO-LL leadless package allows more compact and space-saving power converters. Thanks to the additional Kelvin-source lead, designers can achieve better efficiency due to reduced turn-on / turn-off switching losses.

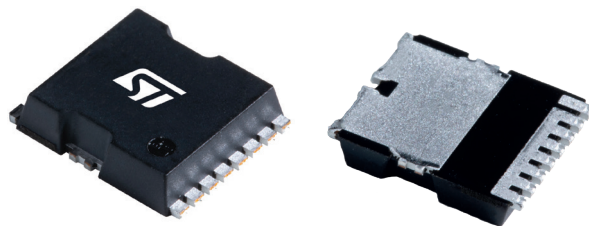

KEY FEATURES

- Reduced space on board
- Distributed heat sinks
- Additional Kelvin-source
- Reduced thickness (2.3 mm)
- High creepage (distance 2.7 mm)

KEY BENEFITS

- Increased power density
- Competitive thermal dissipation
- Improvement in Turn-on / Turn-off efficiency

KEY APPLICATIONS

- Servers
- Telecom 5G SMPS
- Solar Microinverters

Note: * is a registered and/or unregistered trademark of STMicroelectronics International NV or its affiliates in the EU and/or elsewhere

TO-LL with STPOWER MOSFET MDmesh M6 and MDmesh DM6 series

The TO-Leadless (TO-LL) package solution was tested against the TO-247 in the PFC and LLC sections of a 1.5 kW SMPS to compare their respective thermal performance and efficiency. The additional Kelvin-source lead generates significant efficiency gains in the PFC section at full load with high current levels, thanks to the reduction of the inductive effect on the turn-on commutation. The efficiency in the LLC section remains identical for both packages.

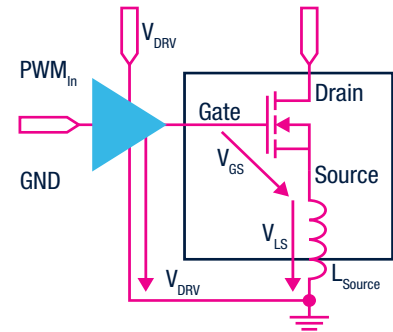

Power efficiency in PFC section

System Power Efficiency

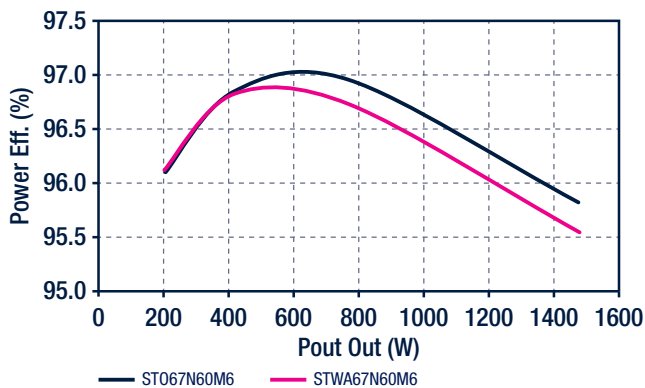

Power efficiency in LLC section

System Power Efficiency

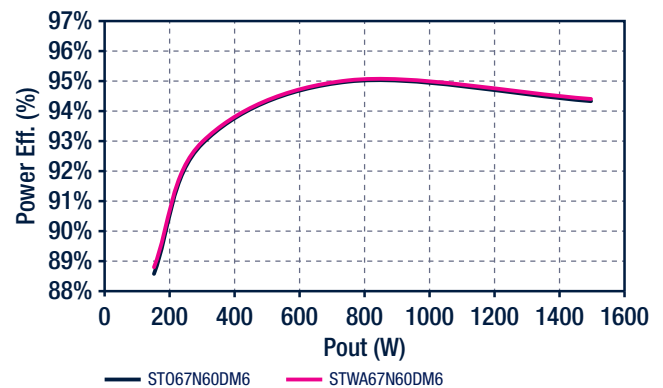

Product portfolio in TO-LL package

B_{VDS} (V)	$R_{DS(on)}$ (Ω)	I_o (A)	Q_o (nC)	Sales Type	Package	Technology
600	0.190	TBD	TBD	ST024N60M6	TO-LL	MDmesh M6
	0.125	30	38	ST033N60M6		
	0.099	34	47	ST036N60M6		
	0.080	40	57	ST047N60M6		
	0.054	38	80	ST067N60M6		MDmesh DM6
	0.078	TBD	61	ST065N60DM6*		
	0.076	40	65	ST052N60DM6*		
650	0.054	38	80	ST067N60DM6		
	0.059	34	80	ST068N65DM6*		

Note: * coming soon by Q4 2020



© STMicroelectronics - September 2020 - Printed in the United Kingdom - All rights reserved
 ST and the ST logo are registered and/or unregistered trademarks of STMicroelectronics International NV or its affiliates in the EU and/or elsewhere. In particular, ST and the ST logo are Registered in the US Patent and Trademark Office.
 For additional information about ST trademarks, please refer to www.st.com/trademarks.
 All other product or service names are the property of their respective owners.

