

MD21605D6W-FPTLRGB	2 x 16	5mm Character Height	LCD Module
<b>Specification</b>			
Version: 1		Date: 12/02/2021	
<b>Revision</b>			
1	10/02/2021	First Issue	

Display Features		
Character Count	2 x 16	
Appearance	Black on RGB	
Logic Voltage	5V	
Interface	Parallel	
Font Set	English / Japanese	
Display Mode	Transflective	
Character Height	5.23mm	
LC Type	FSTN	
Module Size	85.00 x 29.50 x 13.50 mm	
Operating Temperature	-20°C ~ +70°C	
Construction	COB	
LED Backlight	RGB	
	Box Quantity	---
	Weight / Display	---

\* - For full design functionality, please use this specification in conjunction with the ST7066U + ST7065C specification. (Provided Separately)

Display Accessories	
Part Number	Description

Optional Variants		
Fonts	Appearances	Voltage



## FEATURES

AVAILABLE OPTIONS	CHARACTERISTICS
DISPLAY FORMAT	16 Characters by 2 Lines
POLARIZER OPTIONS	Positive Transflective
BACKLIGHT TYPE OPTIONS	Edge Type LED Backlight (Long life span version)
BACKLIGHT COLOR OPTIONS	RGB color
LCD PANEL OPTIONS	FSTN
VIEWING ANGLE OPTIONS	6:00 ( Bottom )
TEMPERATURE RANGE OPTIONS	-20°C ~ 70°C, Single Supply Voltage
SUGGESTED DRIVING VOLTAGE	Vlcm = 5.0V, Vled = 5.0V
SUGGESTED LED DRIVING MODE	A: LED+, KR:LED-,KG:LED-,KB:LED-
CONTROLLER	ST7066U+ST7065C
FONT MAP CODE	E Version
DRIVING DUTY	1/16
DRIVING BIAS	1/5

## MECHANICAL SPECIFICATIONS

<b>OVERALL SIZE</b>	85.0W x 29.5H	mm	<b>THICKNESS</b>	max 13.5	mm
<b>VIEWING AREA</b>	64.5W x 16.4H	mm	<b>HOLE-HOLE</b>	81.0W x 24H	mm
<b>CHARACTER SIZE</b>	3.0W x 5.23H	mm	<b>CHARACTER PITCH</b>	0.51W x 0.52H	mm
<b>DOT SIZE</b>	0.56W x 0.61H	mm	<b>DOT PITCH</b>	0.05W x 0.05H	mm

## ABSOLUTE MAXIMUM RATINGS

ITEM	SYMBOL	CONDITION	MIN	TYP	MAX	UNIT
POWER SUPPLY ( LOGIC)	Vdd	25°C	-0.3	—	7.0	V
POWER SUPPLY (LCD)	V0	25°C	Vdd -13.5	—	Vdd +0.3	V
INPUT VOLTAGE	Vin	25°C	-0.3	—	Vdd +0.3	V
OPERATING TEMPERATURE	Vopr	—	-20	—	70	°C
STORAGE TEMPERATURE	Vstg	—	-30	—	80	°C

## ELECTRONIC CHARACTERISTICS \*

	ITEM	SYMBOL	CONDITION	MIN	TYP	MAX	UNIT
	INPUT VOLTAGE	Vlcm = Vdd	—	—	5.0	—	V
	SUPPLY CURRENT	Idd	Vdd=5.0V	—	1.5	—	mA
	DRIVING VOLTAGE FOR LCD PANEL	Vlcd = (Vdd - V0)	-20°C	4.30	—	4.80	V
			0°C	4.25	—	4.75	
			25°C	4.20	4.50	4.70	
50°C			4.05	—	4.60		
			70°C	3.90	—	4.50	

## LCD CHARACTERISTICS

FOR STN/FSTN TYPE LCD Panel (TA=25°C, VIcd=5.0V ± 0.5V)							
	ITEM	SYMBOL	CONDITION	MIN	TYP	MAX	UNIT
	VIEWING ANGLE	$\Phi 2 - \Phi 1$	K=4	40	—	—	deg
		$\theta$		60			
	CONTRAST RATIO	K	—	6	—	—	—
	RESPONSE TIME(RISE)	TR	—	—	150	250	ms
	RESPONSE TIME(FALL)	TF	—	—	150	250	ms

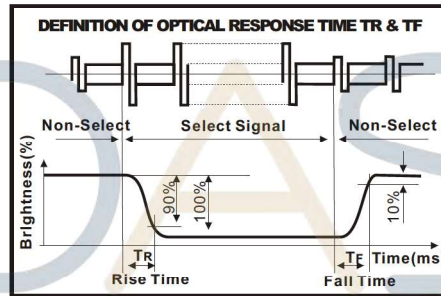
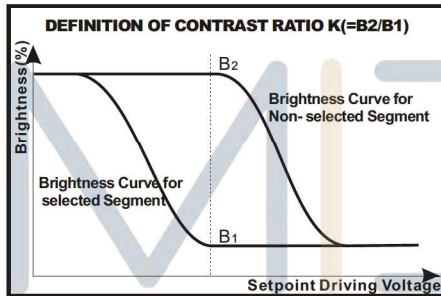
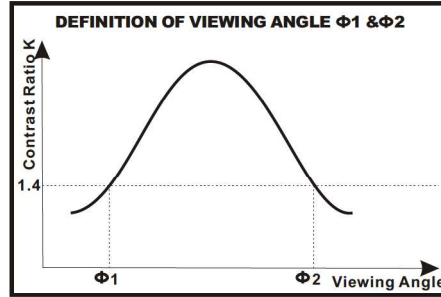
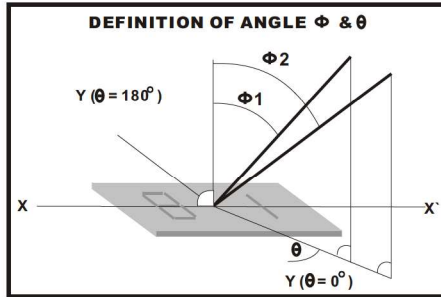

## LED CHARACTERISTICS

	ITEM	SYMBOL	CONDITION	MIN			TYP			MAX			UNIT
	LED FORWARD VOLTAGE	Vf	25°C	R	G	B	R	G	B	R	G	B	V
				1.8	2.9	2.9	—	—	—	2.2	3.4	3.4	
	LED FORWARD CURRENT <b>▲2</b>	If	25°C	—	—	—	—	—	—	20	20	20	mA
	LED REVERSE CURRENT	Ir	25°C	—	—	—	—	—	—	10	10	10	μA/LED
	LED PEAK WAVE LENGTH	$\lambda_p$	25°C	620	520	465	—	—	—	630	530	475	nm
	LED BRIGHTNESS (WITHOUT LCD)	Lv	25°C	—	—	—	30	135	35	—	—	—	cd/m <sup>2</sup>
	LED BRIGHTNESS UNIFORMITY	Lvmin/Lvmax	25°C	70			—			—			Ratio
	LED LIFE TIME	—	25°C	20K			—			—			Hours

**▲2** 请注意, 驱动背光考虑的是恒流而不是恒压. 所以, 这个数值非常重要!

YOUR ATTENTION: It is constant current (not constant voltage) that should be applied when driving LED backlight. Therefore, this data is very important!

\* 当工作温度高于25°C时, Ifm, Ifp和Pd必须降低; 电流降低率是 -0.36\*6mA/°C (直流驱动), 或-0.86\*6mA/°C (脉冲驱动), 功率降低率是-75\*6mW/°C. 产品工作电流不能大于对应的工作条件温度Ifm或Ifpr的60%.

For operation above 25°C, The Ifm Ifp & Pd must be derated, the Current derating is -0.36\*6mA/°C for DC drive and -0.86\*6mA/°C for Pulse drive, the power dissipation is -75\*6 mW/°C The product working current must not be more than 60% of the Ifm or Ifp according to the working temperature.



## PIN ASSIGNMENT

PIN	SYMBOL	DESCRIPTION	REMARKS
1	Vdd	Power supply for LCM	5.0V
2	Vss	GND	
3	V0	Contrast Adjust	
4	RS	Register Select Signal	
5	R/W	Data Read / Write	
6	E	Enable Signal	
7	DB0	Data bus line	
8	DB1	Data bus line	
9	DB2	Data bus line	
10	DB3	Data bus line	
11	DB4	Data bus line	
12	DB5	Data bus line	
13	DB6	Data bus line	
14	DB7	Data bus line	
	A	Power supply for BKL	5.0V
	KR	Power supply for BKL	0V
	KG	Power supply for BKL	0V
	KB	Power supply for BKL	0V

## BLOCK DIAGRAM

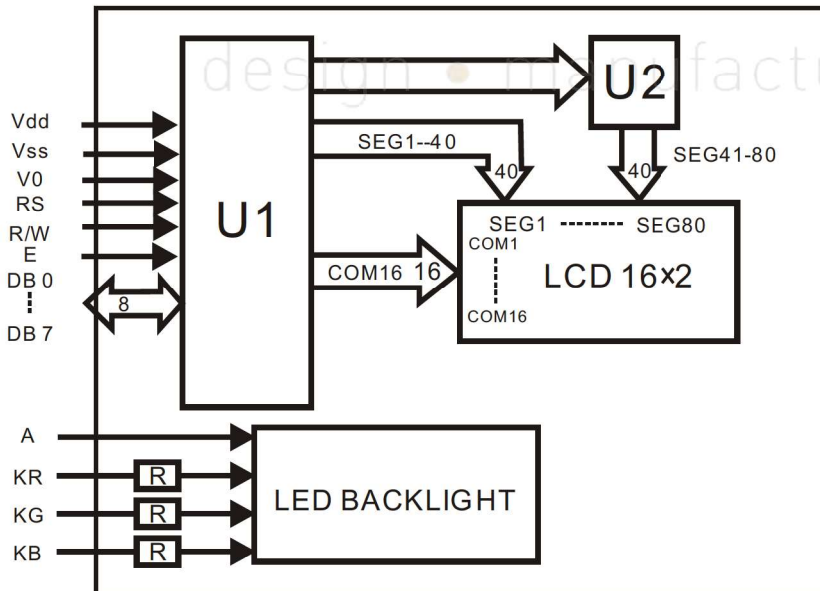

## POWER SUPPLY DIAGRAM

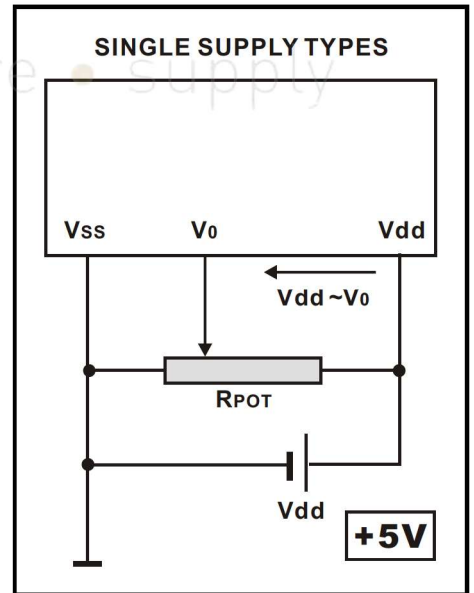



Upper 4bit Lower 4bit	LLLL	LLLH	LLHL	LLHH	LHLL	LHLH	LHHL	LHHH	HLLL	HLLH	HLHL	HLHH	HHLL	HHLH	HHHL	HHHH
LLLL	CG RAM (1)															
LLLH	(2)															
LLHL	(3)															
LLHH	(4)															
LHLL	(5)															
LHLH	(6)															
LHHL	(7)															
LHHH	(8)															
HLLL	(1)															
HLLH	(2)															
HLHL	(3)															
HLHH	(4)															
HHLL	(5)															
HHLH	(6)															
HHHL	(7)															
HHHH	(8)															



