

HITACHI

KAOHSIUNG HITACHI
ELECTRONICS CO.,LTD
P.O. BOX 26-27
2,13TH EAST ST. K.E.P.Z.
KAOHSIUNG TAIWAN R.O.C.
TEL:(07) 8215811 (7 LINE)
FAX:(07) 8215815

FOR MESSRS : _____

DATE. Apr.16,2004

Customer's Acceptance Specifications

SP14N003

CONTENTS

No.	ITEM	SHEET No.	PAGE
1	COVER	7B64PS 2701-SP14N003-3	1-1/1
2	RECORD OF REVISION	7B64PS 2702-SP14N003-3	2-1/1
3	GENERAL SPECIFICATION	7B64PS 2703-SP14N003-3	3-1/1
4	ABSOLUTE MAXIMUM RATINGS	7B64PS 2704-SP14N003-3	4-1/1
5	ELECTRICAL CHARACTERISTICS	7B64PS 2705-SP14N003-3	5-1/1
6	OPTICAL CHARACTERISTICS	7B64PS 2706-SP14N003-3	6-1/2~2/2
7	BLOCK DIAGRAM	7B64PS 2707-SP14N003-3	7-1/1
8	INTERFACE TIMING CHART	7B64PS 2708-SP14N003-3	8-1/2~2/2
9	OUTLINE DIMENSIONS	7B63PS 2709-SP14N003-3	9-1/3
		7B64PS 2709-SP14N003-3	9-2/3~3/3
10	APPEARANCE STANDARD	7B64PS 2710-SP14N003-3	10-1/4~4/4
11	PRECAUTION IN DESIGN	7B64PS 2711-SP14N003-3	11-1/3~3/3
12	DESIGNATION OF LOT MARK	7B64PS 2712-SP14N003-3	12-1/1
13	PRECAUTION FOR USE	7B64PS 2713-SP14N003-3	13-1/1

* When product will be discontinued , customer will be informed by HITACHI with twelve months prior announcement.

ACCEPTED BY : _____

PROPOSED BY : Jimmy Ho

KAOHSIUNG HITACHI ELECTRONICS CO.,LTD.	Sh. No.	7B64PS 2701-SP14N003-3	PAGE	1-1/1
---	------------	------------------------	------	-------

RECORD OF REVISION

DATE	SHEET No.	SUMMARY
May 29,'02	7B64PS 2703- SP14N003-2 PAGE 3-1/1	CHANGED: 3.MECHANICAL DATA (1) Part Name SP14N002 → SP14N003 (10) LCD Controller IC LC7981A → LC7981
	7B64PS 2708- SP14N003-2 PAGE 8-1/2	CHANGED: 8.INTERFACE TIMING CHART Ta=-20 to 75°C → Ta=0 to 50°C
	7B64PS 2708- SP14N003-2 PAGE 8-2/2	CHANGED: 8.2 Timing of power supply and interface signal Note : controller LC7982A → LC7981
Apr.16,'04	7B63PS 2709- SP14N003-3 PAGE 9-1/3	Changed : Revised : CFL cable length (50) → (56)

3. GENERAL SPECIFICATION

- | | |
|------------------------|---|
| (1) Part Name | SP14N003 |
| (2) Module Size | 159.4(W)mm × 101.0(H)mm × 11.0(D)mm max. |
| (3) Dot Size | 0.47(W)mm x 0.47(H)mm |
| (4) Dot Pitch | 0.50(W)mm × 0.50(H)mm |
| (5) Number Of Dots | 240(W) x 128(H)dots |
| (6) Duty | 1/128 |
| (7) LCD Type | Blue type (Negative type)
The upper polarizer is anti-glare type.(Hardness.3H)
The bottom polarizer is transmissive type. |
| (8) Viewing Direction | 6 O'clock |
| (9) Backlight | Cold cathode fluorescent lamp |
| (10) LCD Controller IC | LC7981 / SANYO |

4. ABSOLUTE MAXIMUM RATINGS

4.1 Electrical Absolute Maximum Ratings.

VSS = 0V : Standard

ITEM	SYMBOL	MIN.	MAX.	UNIT	COMMENT
Power Supply For Logic	VDD-VSS	0	6.5	V	
Power Supply For LC Drive	VDD-VEE	0	20.5	V	
Input Voltage	Vi	-0.3	VDD+0.3	V	
Input Current	li	0	1	A	
Static Electricity	-	-	-	-	(Note 1)

Note 1 : Make certain you are grounded when handling LCM.

4.2 Environmental Absolute Maximum Ratings

ITEM	OPERATING		STORAGE		COMMENT
	MIN.	MAX.	MIN.	MAX.	
Ambient Temperature	0°C	50°C	-20°C	60°C	(Note 2,3)
Humidity	(Note 1)		(Note 1)		Without Condensation
Vibration	-	4.9m/s ² (0.5G)	-	19.6m/s ² (2G) (Note 5)	(Note 4)
Shock	-	29.4m/s ² (3G)	-	490.0m/s ² (50G)	XYZ Directions
Corrosive Gas	Not Acceptable		Not Acceptable		

Note 1 : Ta ≤ 40°C : 85%RH max.

Ta > 40°C : Absolute humidity must be lower than the humidity of 85%RH at 40°C

Note 2 : Ta at -20°C —< 48h, at 60°C —< 168h.

Note 3 : Background color changes slightly depending on ambient temperature.

This phenomenon is reversible.

Higher starting voltage of CFL and higher LCD driving voltage are needed while operating at 0°C.

The life time of CFL will be reduced while operating at 0°C. Need to make sure the value of IL and characteristics of inverter.

Also the response time at 0°C will be slower.

Note 4 : 5Hz~100Hz (Except Resonance Frequency)

Note 5 : This module should be operated normally after finishing the test.

5. ELECTRICAL CHARACTERISTICS

5.1 Electrical Characteristics Of LCM

ITEM	SYMBOL	CONDITION	MIN.	TYP.	MAX.	UNIT
Power Supply Voltage for Logic	VDD-VSS	-	4.75	5.0	5.25	V
LC Driver Circuit Power Supply Voltage	VEE-VSS	-	-15.5	-15.0	-14.5	V
Input Voltage	VI	H Level	0.8VDD	-	VDD	V
		L Level	0	-	0.2VDD	V
Power Supply Current for Logic (Note 1)	IDD	VDD-VSS=5.0V	-	9.7	12.0	mA
Power Supply Current for LCD Driving (Note 1)	IEE	VDD-VSS=5.0V	-	2.5	4.0	mA
Recommended LC Driving Voltage (Note 2)	VDD-V0	Ta= 0°C , $\phi = 0^\circ$	-	16.9	-	V
		Ta=25°C , $\phi = 0^\circ$	-	15.8	-	V
		Ta=50°C , $\phi = 0^\circ$	-	15.2	-	V
Frame Frequency (Note 2)	fFrame	-	-	75	-	Hz

Note 1 : fFrame=75Hz, VDD-V0=15.8V, Ta=25°C

Note 2 : Recommended LC driving voltage fluctuate about $\pm 1.0V$ by each module.

Test pattern is all "Q"

Note 3 : Need to make sure of flickering and rippling of display when setting the frame frequency in your set.

5.2 Electrical Characteristics Of Backlight

ITEM	SYMBOL	MIN.	TYP.	MAX.	UNIT	NOTE
Lamp Voltage	VL	-	360	-	V	Ta=25°C
Frequency	FL	30	70	85	KHz	Ta=25°C
Lamp Current	IL	2.5	5	5.5	mA	Ta=25°C
Start Discharge Voltage	VS (Note 2)	(1000)	-	-	V	Ta=25°C

Note 1 : Please certainly inform HITACHI before designing lamp drive circuit according to the above specifications.

Note 2 : Starting discharge voltage is increased when LCM is operating at lower temperature. Please check the characteristics of inverter before applying

Note 3 : Average life time of CFL will be decreased when LCM is operating at lower temperature.

6. OPTICAL CHARACTERISTICS

6.1 Optical Characteristics

Ta=25°C (Backlight On)

ITEM	SYMBOL	CONDITIONAL	MIN.	TYP.	MAX.	UNIT	NOTE
Viewing Area	$\phi 2-\phi 1$	$K \geq 2.0$	30	40	-	deg.	1,2
Contrast Ratio	K	$\phi = 10^\circ, \theta = 0^\circ$	-	7	-	-	3
Response Time (Rise)	tr	$\phi = 10^\circ, \theta = 0^\circ$	-	(160)	-	ms	4
Response Time (Fall)	tf	$\phi = 10^\circ, \theta = 0^\circ$	-	(110)	-	ms	4

(Measure condition by HITACHI)

Note 1 : Definition of θ and ϕ
z (Normal)

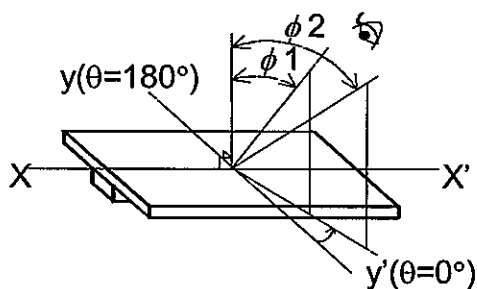

Note 3 : Definition of contrast "K"

$$K = \frac{\text{Brightness on selected dot (B1)}}{\text{Brightness on non-selected dot (B2)}}$$

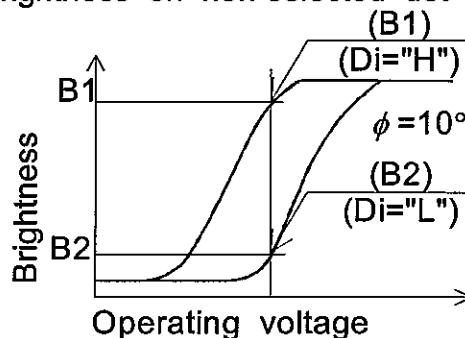

Note 2 : Definition of viewing angle
 $\phi 1$ and $\phi 2$.

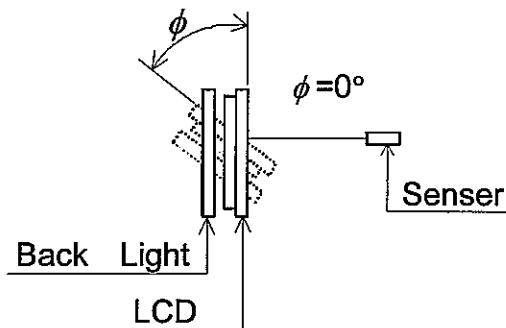
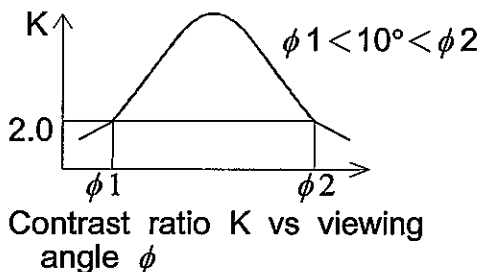

Note 4 : Definition of optical response

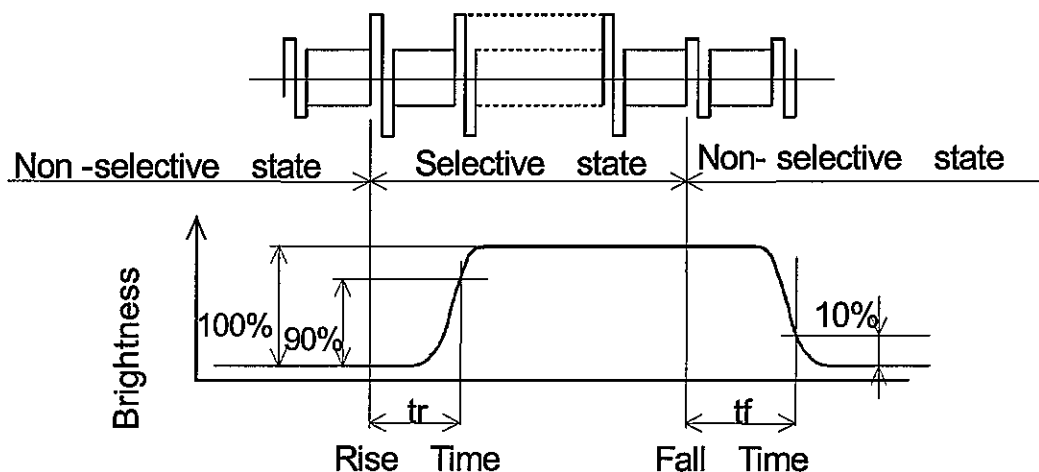

6.2 Optical Characteristics Of Backlight

(LCM, Backlight On, Ta = 25°C)

I T E M	MIN.	TYP.	MAX.	UNIT	NOTE
Brightness	70.0	90.0	-	cd / m ²	IL= 5mA (Note 1,2)
Rise Time	-	5	-	Minute	IL= 5mA Brightness 80%
Brightness Uniformity	-	-	±30	%	Undermentioned (Note 1,3)

CFL : Inital, Ta=25°C, VDD - V0=15.8V
Display data should be all "ON".

Note 1 : Measurement after 10 minutes of CFL operating.

Note 2 : Brightness control : 100%

Note 3 : Measurement of the following 9 places on the display.
Definition of the brightness tolerance.

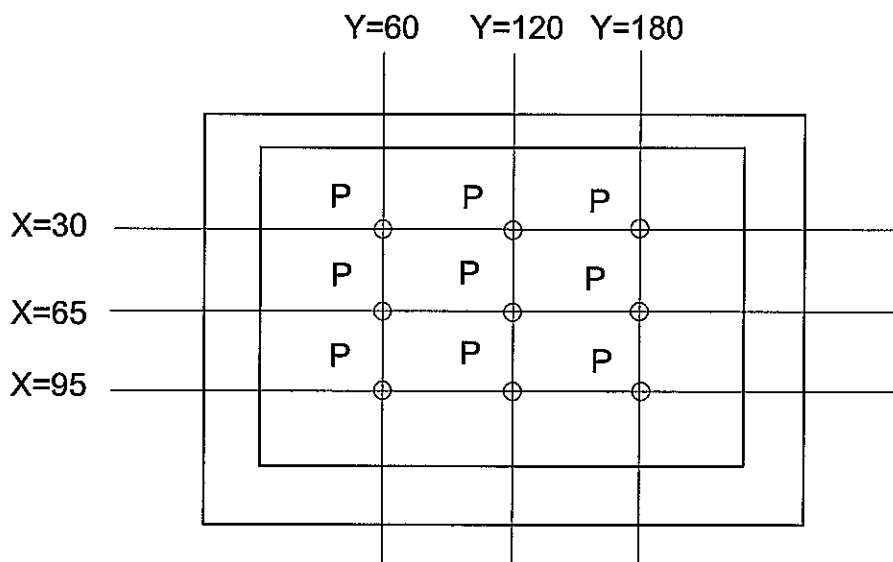

$$\left(\frac{\text{max. brightness or min. brightness} - \text{Average brightness}}{\text{Average brightness}} \right) \times 100$$

7. BLOCK DIAGRAM

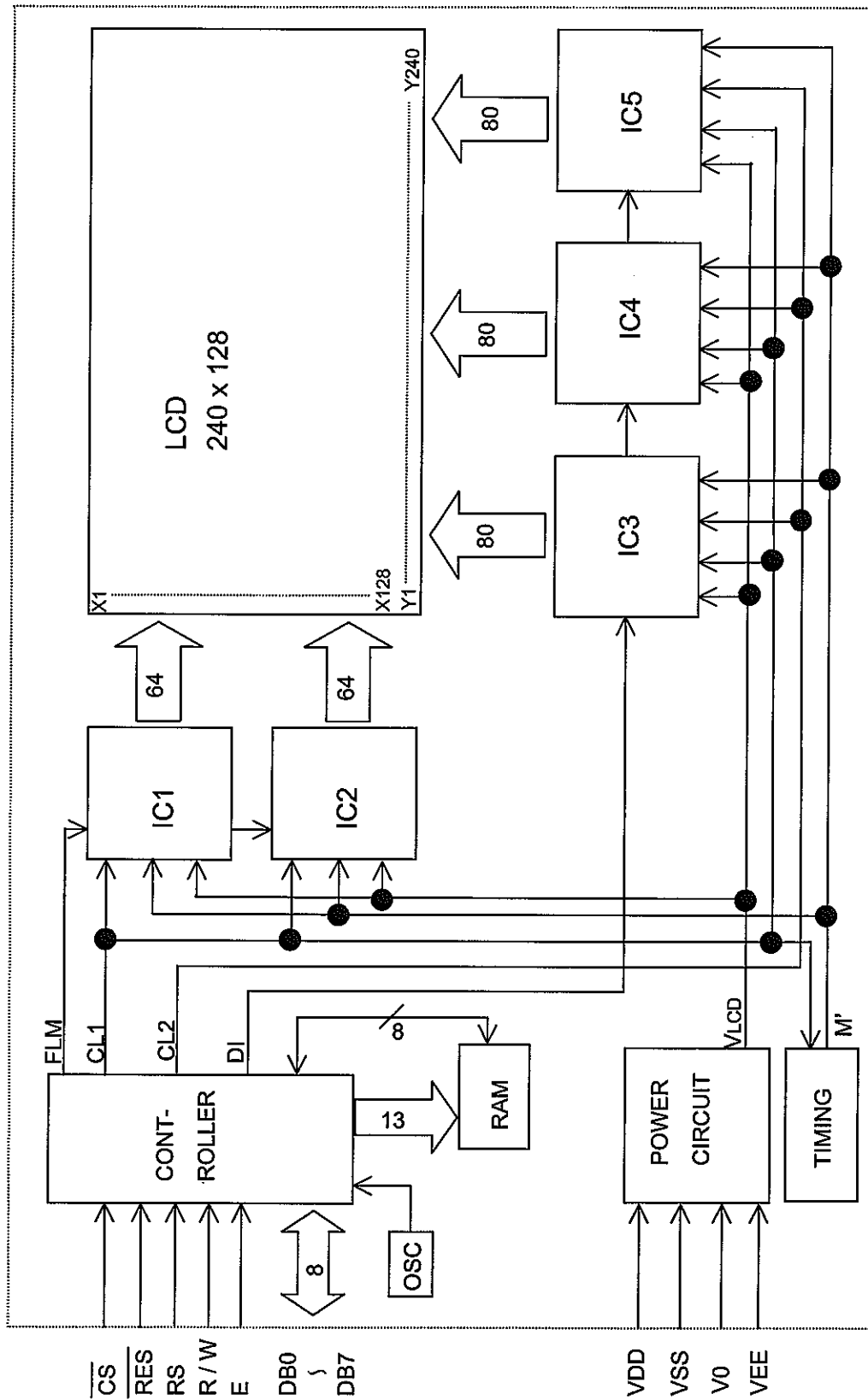

8. INTERFACE TIMING CHART

8.1 INTERFACE TIMING CHART

- Bus read / write operation 1

Read cycle

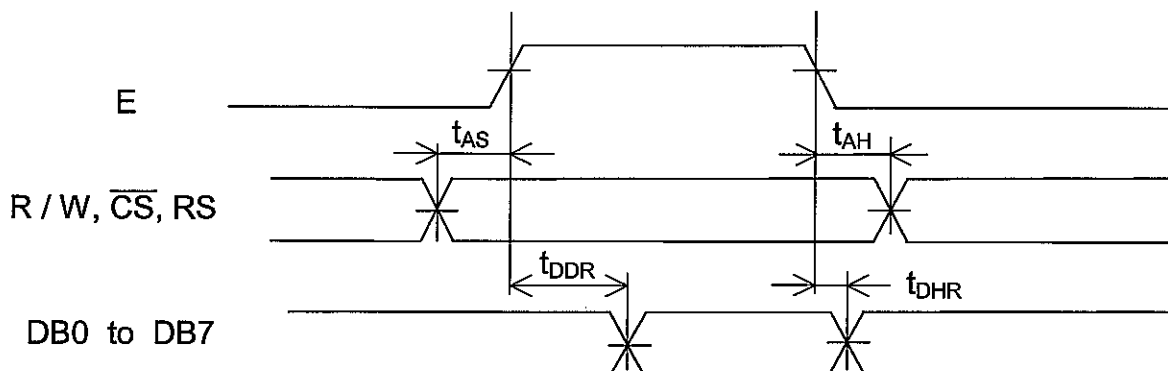

Write cycle

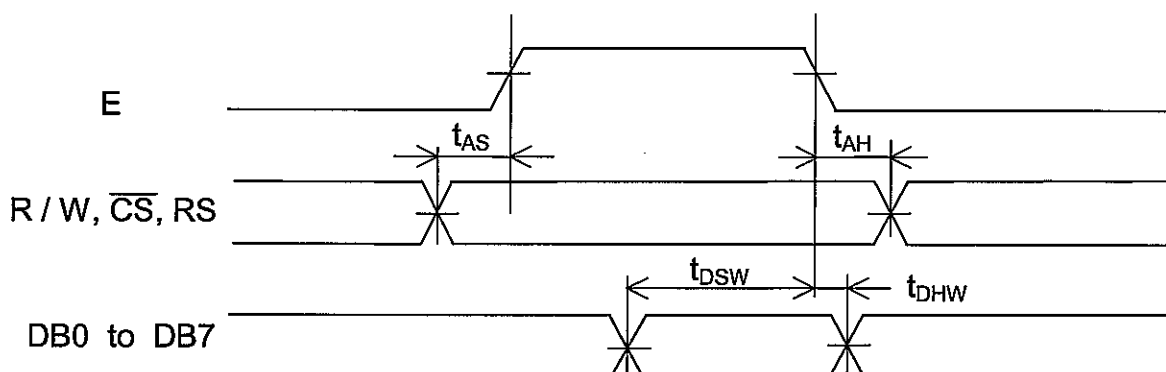

$T_a = 0$ to $+50^\circ\text{C}$, $V_{DD} = 5\text{V} \pm 5\%$, $\text{GND} = 0\text{V}$

PARAMETER	SYMBOL	CONDITIONS	RATINGS			UNIT
			min.	typ.	max.	
Address Setup Time	t_{AS}		90			ns
Address Hold Time	t_{AH}		10			ns
Data Delay Time (Read)	t_{DDR}	$C_L = 50 \text{ pF}$			140	ns
Data Hold Time (Read)	t_{DHR}		10			ns
Data Setup Time (Write)	t_{DSW}		220			ns
Data Hold Time (Write)	t_{DHW}		20			ns

8.2 Timing of power supply and interface signal

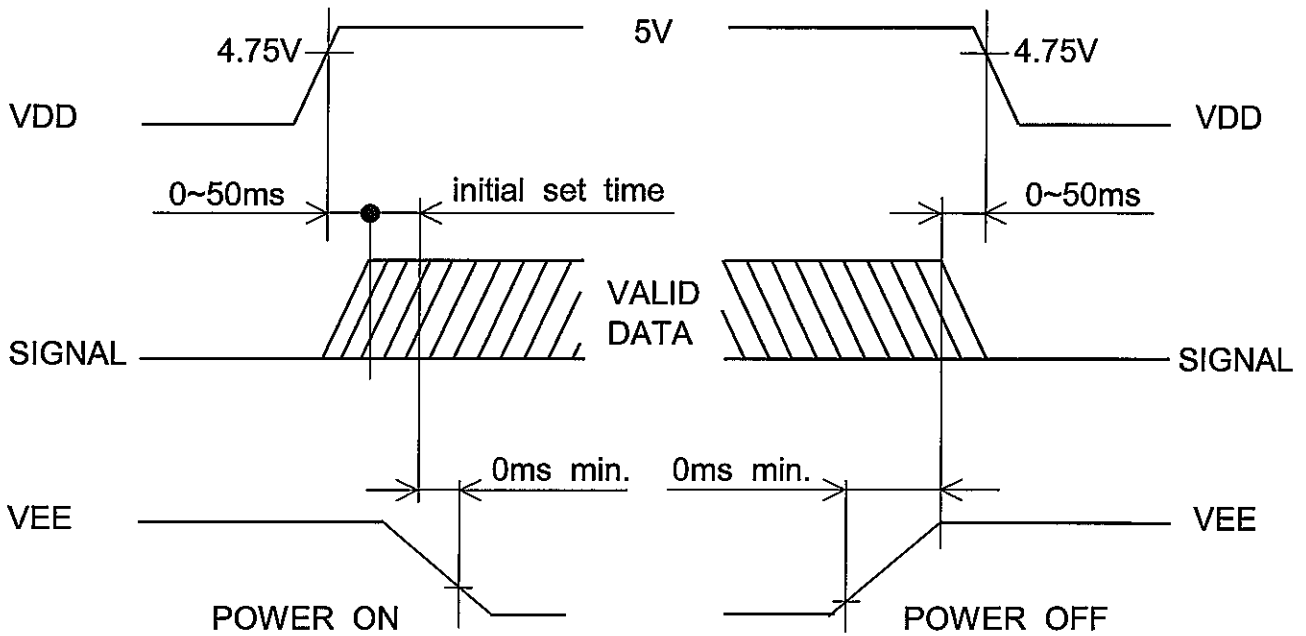

Note : Initial set time – the time is initial instructions set time of controller LC7981
(Initial Instructions) :

- ① Mode Control
- ② Set Character Pitch
- ③ Set Number Of Character
- ④ Set Number Of Time Division.

8.3 Power supply for LCM (Example)

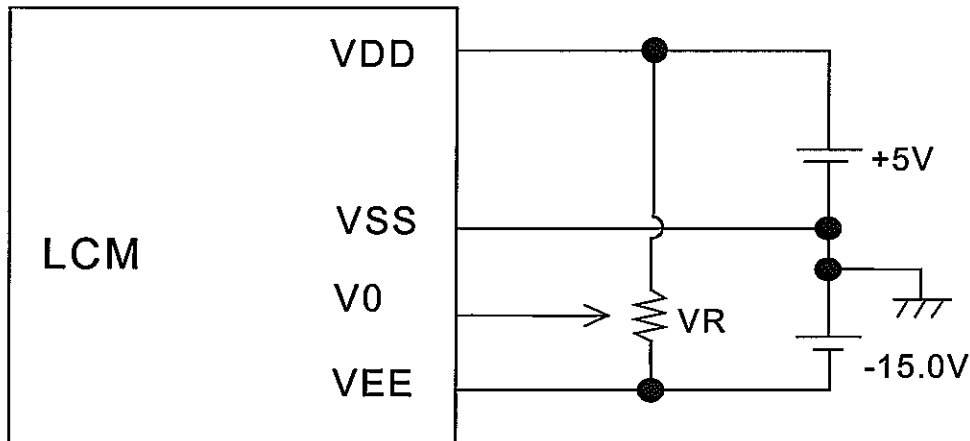

VR : 10~20k Ω

VDD – V0 : LCD Driving Voltage

9. OUTLINE DIMENSIONS
9.1 OUTLINE DIMENSIONS

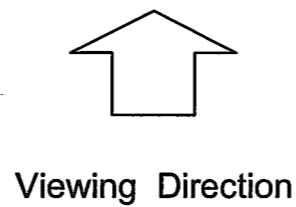
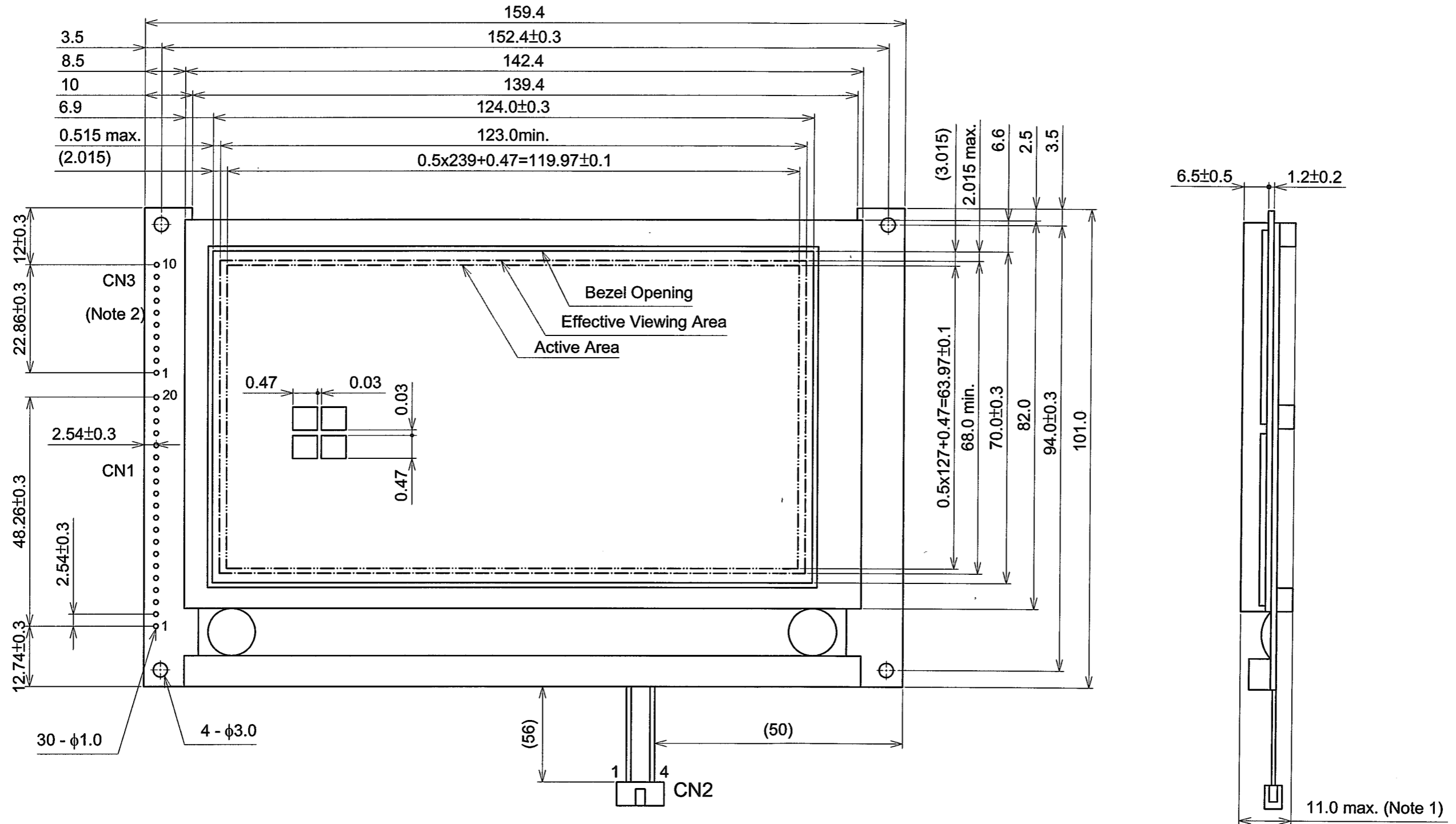

Unit : mm
Scale : NTS
Tolerance not specified is ±0.5mm
Note 1 : Measurement when adding 9.8×10^4 PA
(1.0 kgf/cm^2) At the measuring point
Note 2 : Do not connect any signal to CN3.
Use CN1 as interface

9.2 DISPLAY PATTERN

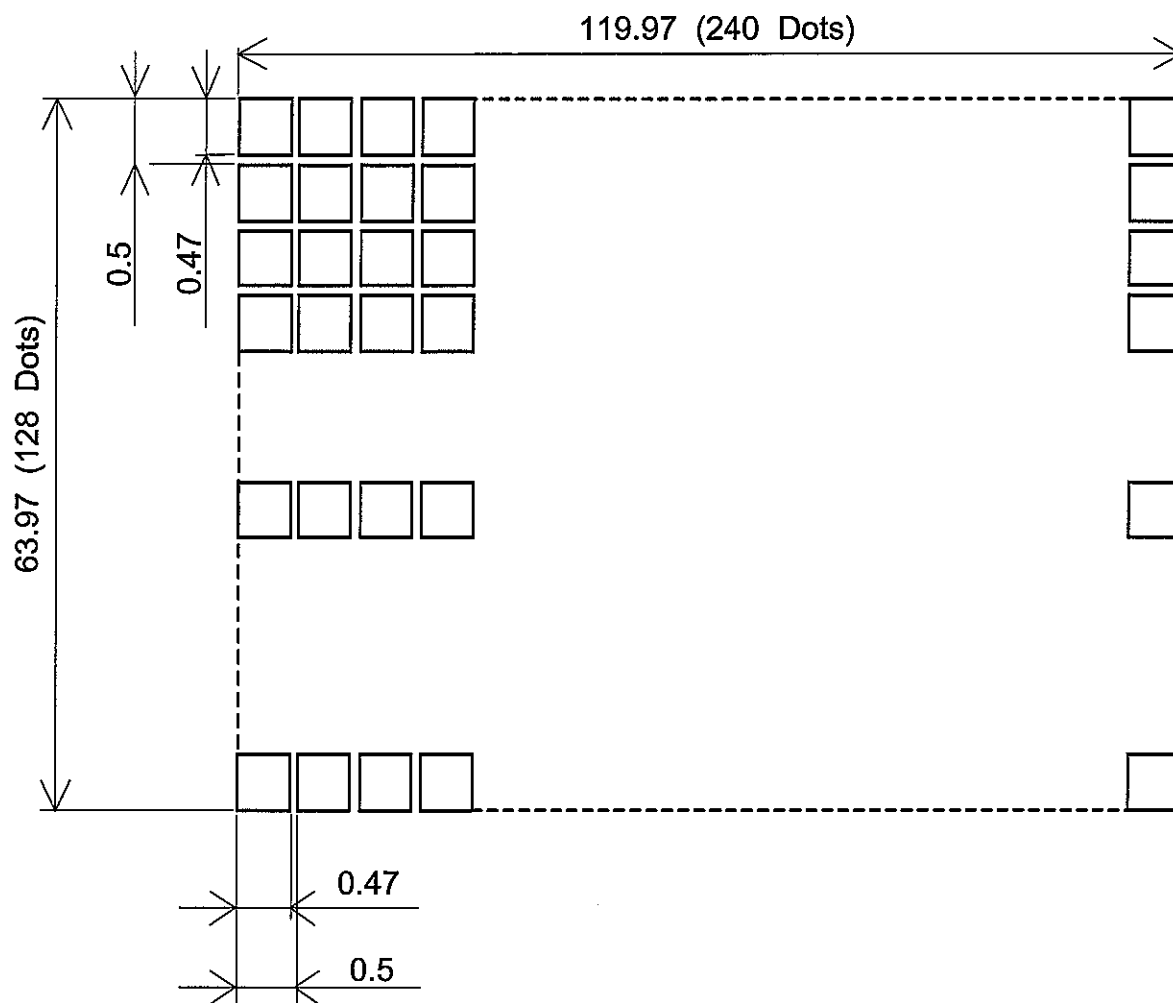

Scale: NTS

Unit : mm

Measurement Tolerance : ± 0.1

9.3 Internal Pin Connection

CN1 :

PIN No.	SYMBOL	FUNCTION
A1	VSS(0V)	Ground
A2	VDD(+5V)	Power supply for logic
A3	V0	Power supply for LCD drive
A4	RS	Register select
A5	R / W	Read / write
A6	E	Enable
A7~14	DB0~DB7	Data bus
A15	CS	Chip select
A16	RES	Reset
A17	VEE(-15.0V)	Power supply for LCD drive
A18	DOFF	NC / Display GND / Display off
A19~20	N.C	No connection

CN2 :

INTERFACE	PIN No.	SYMBOL	LEVEL	FUNCTION	
CFL	CFL I / F	1	GND	————	CFL GND
		2	N.C	————	————
		3	N.C	————	————
		4	H.V.	————	Power supply for CFL

CFL I / F : Mitsumi M63M83 - 04

(Suitable Connector : Mitsumi M61M73 - 04
 Mitsumi M60 - 04 - 30 - 114P(Straight)
 Mitsumi M60 - 04 - 30 - 134P(Angle))

10. APPEARANCE STANDARD

10.1 Appearance inspection condition.

Visual inspection should be done under the following condition.

- (1) In the dark room
- (2) With CFL panel lighted with prescribed inverter circuit.
- (3) With eyes 25cm distance from LCM.
- (4) Viewing angle within 45 degrees from the vertical line to the center LCD

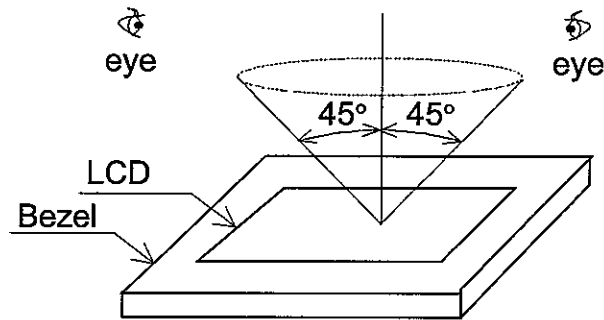

10.2 Definition of each zone

A ZONE : Within the effective display area specified at page 9-1/3 of this document.

B ZONE : Area between the window of bezel line and the effective display area line specified at page 9-1/3 of this document.

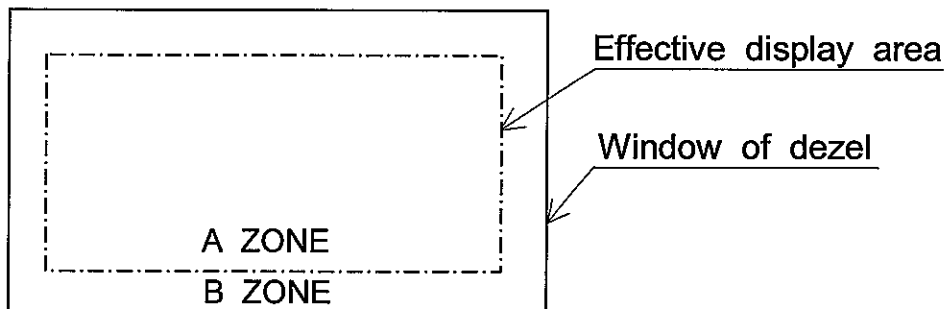

10.3 Appearance Specification

(1) LCD Appearance

※) If the problem occurs about this item. The responsible person of both party (Customer and HITACHI) will discuss more detail.

No.	ITEM	CRITERIA		A	B	
L C D	Scratches	Distinguished one is not acceptable (To be judged by HITACHI standard)		※	-	
	Dent	Same as above		※	-	
	Wrinkles In Polarizer	Same as above		※	-	
	Bubbles	Average Diameter D(mm)		Maximum Number Acceptable	0	-
		$D \leq 0.2$		Ignore		
		$0.2 < D \leq 0.3$		5		
		$0.3 < D \leq 0.5$		1		
		$0.5 < D$		None		
	Stains, Foreign Materials, Dark Spot	Filamentous			0	-
		Length L(mm)	Width W(mm)	Maximum Number Acceptable		
		$L \leq 2.0$	$W \leq 0.03$	Ignore		
		$L \leq 3.0$	$0.03 < W \leq 0.05$	3		
		-	$0.05 < W$	None		
	Round	Average Diameter D(mm)		Maximum Number Acceptable	0	-
		$D \leq 0.2$		Ignore		
		$0.2 \leq D < 0.3$		3		
		$0.3 \leq D < 0.4$		2		
		$0.4 \leq D$		None		
		The whole number		Filamentous+Round=5		
		Those wiped out easily are acceptable				
	Color Tone	To be Judged by HITACHI standard		0	-	
Color Uniformity	Same as above		0	-		
Pinhole	$(A+B) / 2 \leq 0.15$		Maximum Number : Ignored	0	-	
	$0.15 < (A+B) / 2 \leq 0.3$		Maximum Number : Ignored			
	$C \leq 0.03$		Maximum Number : Ignored			

No.	ITEM	CRITERIA			A	B	
L	Contrast Irregularity (Spot)	Average Diameter D(mm)	Contrast	Maximum Number Acceptable	Minimum Space	O	-
		$D \leq 0.25$	To be Judged by Hitachi Standard	Ignore	-		
		$0.25 < D \leq 0.35$		5	20mm		
		$0.35 < D \leq 0.5$		2	20mm		
		$0.5 < D$		None	-		
C D	Contrast Irregularity (A Pair Of Scratch)	Width W(mm)	Length L(mm)	Maximum Number Acceptable	Minimum Space	O	-
		$W \leq 0.25$	$L \leq 1.2$	2	20mm		
		$W \leq 0.2$	$L \leq 1.5$	3	20mm		
		$W \leq 0.15$	$L \leq 2.0$	3	20mm		
		$W \leq 0.1$	$L \leq 3.0$	4	20mm		
The whole			6				
	Rubbing Scratch	To be Judged by HITACHI standard					

No.	ITEM	CRITERIA			A	B
C F L	Dark Spots Irregularity Foreign (Spot)	Average Diameter D(mm)		Maximum Number Acceptable	O	-
		$D \leq 0.4$		Ignored		
		$0.4 < D$		None		
B A C K L I G H T	Foreign Materials (Line)	Width W(mm)	Length L(mm)	Maximum Number Acceptable	O	-
		$W \leq 0.2$	$L \leq 2.5$	1		
		$0.2 < W$	$2.5 < L$	None		
	Scratches	Width W(mm)	Length L(mm)	Maximum Number Acceptable	O	-
		$W \leq 0.1$	-	Ignored		
		$0.1 < W \leq 0.2$	$L \leq 11.0$	1		
			$11.0 < L$	None		
	$0.2 < W$	-	None			

Note 1 : Definition of average diameter D

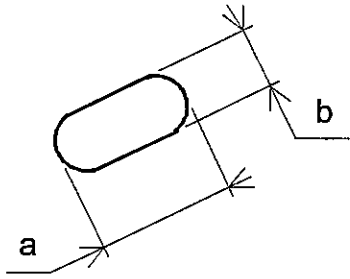

$$D = \frac{a+b}{2}$$

Note 2 : Definition of length L and width W

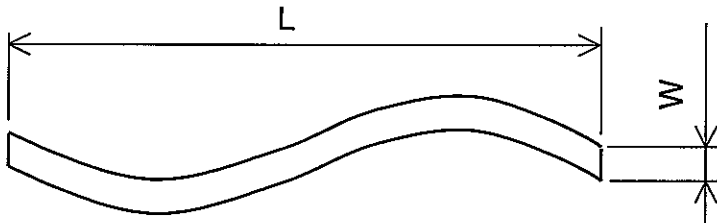

Note 3 : Definition of pinhole

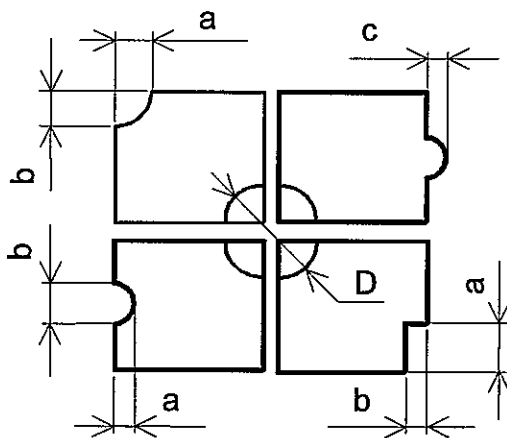

c : Salience

11. PRECAUTION IN DESIGN

11.1 Mounting Method

Since the module is so constructed as to be fixed by utilizing fitting holes in the module as shown below, it is necessary to take consideration the following items on attachment to a frame.

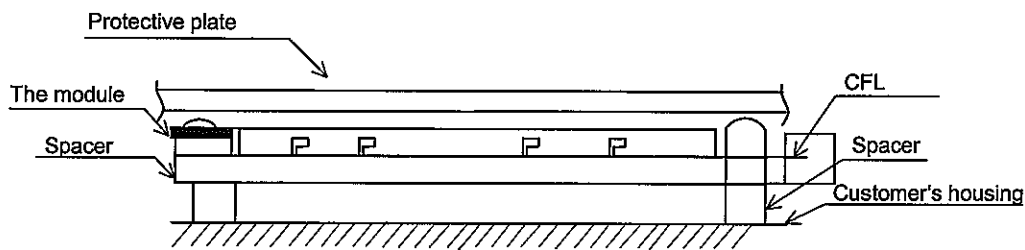

Example of Mounting

Unit : mm
Scale : NTS

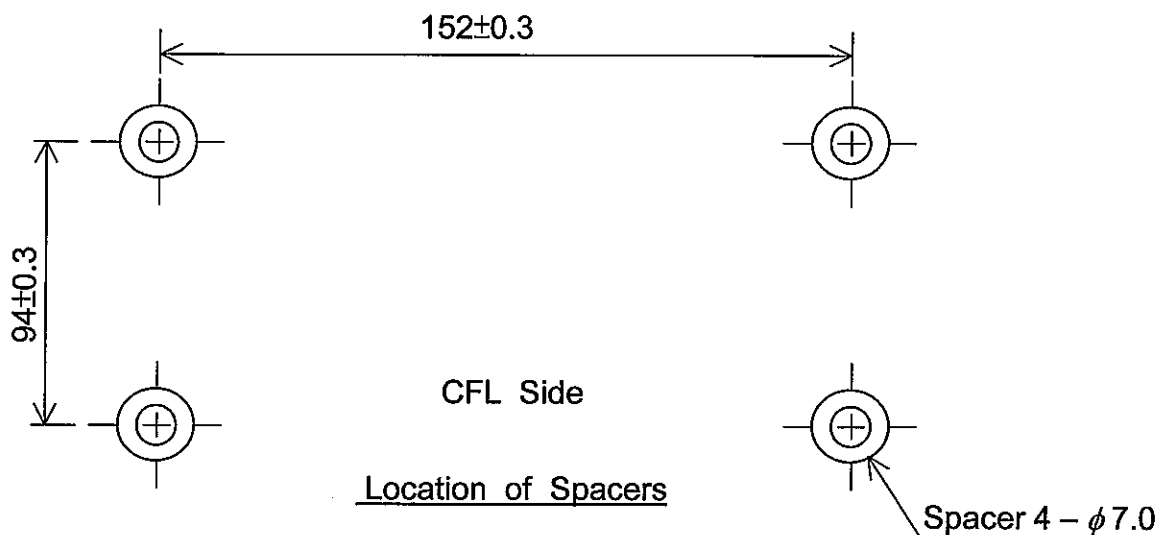

- (1) Use of protective plate, made of an acrylic plate, etc, in order to protect a polarizer and LC cell.
- (2) To prevent the model cover from being pressed, the spacers between the module and the fitting plates should be longer than 0.5mm.
- (3) We recommend you to use protective spacer as figure for protecting LCD module from any kind of shock to your set.

11.2 LC driving voltage (V0) and viewing angle range.

Setting V0 out of the recommended condition will be a cause for a change of viewing angle range.

11.3 Caution Against Static Charge

As this module is provided with C-MOS. LSI, the care to take such a precaution as to grounding the operator's body is required when handling it.

11.4 Power On Sequence

Input signals should not be applied to LCD module before power supply voltage is applied and reaches to specified voltage ($5 \pm 0.25V$).

If above sequence is not kept, C-MOS. LSIs of LCD modules may be damaged due to latch up problem.

11.5 Packaging

- (1) No. leaving product is preferable in the place of high humidity for a long period of time. For their storage in the place where temperature is $35^{\circ}C$ or higher, special care to prevent them from high humidity is required. A combination of high temperature and high humidity may cause them polarization degradation as well as bubble generation and polarizer peel-off. Please keep the temperature and humidity within the specified range for use and storing.
- (2) Since upper polarizers and lower aluminum plates tend to be easily damaged, they should be handled with full care so as not to get them touched, pushed or rubbed by a piece of glass. Tweezers and anything else which are harder than a pencil lead 3H.
- (3) As the adhesives used for adhering upper/lower polarizers and aluminum plates and aluminum plates are made of organic substances which will be deteriorated by a chemical reaction with such chemicals as acetone, talon ethanol and isopropylalcohol. The following solvents are recommended for use:
normal hexane
- (4) Lightly wipe to clean the dirty surface with absorbent cotton waste or other soft material like chamois, soaked in the chemicals recommended without scrubbing it hardly. To prevent the display surface from damage and keep the appearance in good state, in general, to wipe it with absorbent cotton.
- (5) Immediately wipe off saliva or water drop attached on the display area because its long period adherence may cause deformation or faded color on the spot.
- (6) Foggy dew deposited on the surface and contact terminals due to coldness will be a cause for polarizer damage, stain and dirt on product. When necessary to take out the products from some place at low temperature for test, etc. It is required for them to be warmed up in a container once at the temperature higher than that of the room.
- (7) Touching the display area and contact terminals with bare hands and contaminating them are prohibited, because the stain on the display area and poor insulation between terminals are often caused by being touched by bare hands. (There are some cosmetics detrimental to polarizers.)
- (8) In general the quality of glass is fragile so that it tends to be cracked or chipped or chipped in handling, specially on its periphery. Please be careful not to give it sharp shock caused by dropping down, etc.

KAOHSIUNG HITACHI ELECTRONICS CO.,LTD.	DATE	Apr.16,'04	Sh. No.	7B64PS 2711-SP14N003-3	PAGE	11-2/3
---	------	------------	------------	------------------------	------	--------

11.6 Caution For Operation

- (1) It is an indispensable condition to drive LCD's within the specified voltage limit since the higher voltage than the limit causes the shorter LCD life.
An electrochemical reaction due to direct current causes LCD's undesirable deterioration, so that the use of direct current driver should be avoided.
- (2) Response time will be extremely delayed at lower temperature than the operating temperature range and on the other hand at higher temperature LCD show dark blue color in them. However those phenomena do not mean malfunction or out of order with LCD's which will come back to the specified operating temperature range.
- (3) If the display area is pushed hard during operation, some font will be abnormally displayed but it resumes normal condition after turning off once.
- (4) A slight dew depositing on terminals is a cause for electrochemical reaction resulting in terminal open circuit. Usage under the relative condition of 40°C 50%RH or less is required.

11.7 Storage

In case of storing for a long period of time (For instance, for years) for the purpose of replacement use, the following ways are recommended.

- (1) Storage in a polyethylene bag with the opening sealed so as not to enter fresh air outside in it, and with no desiccant.
- (2) Placing in a dark place where neither exposure to direct sunlight nor light is, keeping temperature in the range from 0°C to 35°C.
- (3) Storing with no touch on polarizer surface by anything else. (It is recommended to store them as they have been contained in the inner container at the time of delivery from us.)

11.8 Safety

- (1) It is recommendable to crash damaged or unnecessary LCD's into pieces and wash off liquid crystal by either of solvents such as acetone and ethanol, which should be burned up later.
- (2) When any liquid leaked out of a damaged glass cell comes in contact with your hands, please wash it off well with soap and water.

12. DESIGNATION OF LOT MARK

Lot Mark

Lot mark is consisted of 4 digits for production lot.

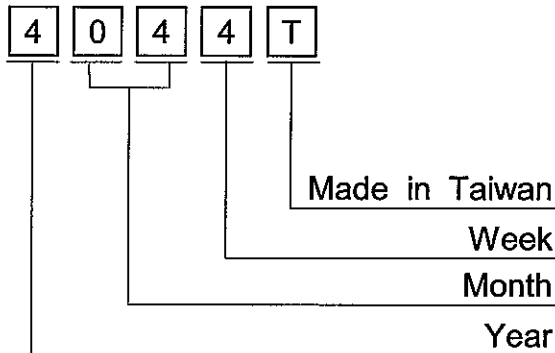

YEAR	FIGURE IN LOT MARK
2004	4
2005	5
2006	6
2007	7

MONTH	FIGURE IN LOT MARK	MONTH	FIGURE IN LOT MARK
Jan.	01	Jul.	07
Feb.	02	Aug.	08
Mar.	03	Sep.	09
Apr.	04	Oct.	10
May	05	Nov.	11
Jun.	06	Dec.	12

WEEK (DAY IN CALENDAR)	FIGURE IN LOT MARK
21~27	1
28~3	2
4~10	3
11~17	4
18~20	5

Location of lot : On the back side of LCM

4 0 4 4 T

13. PRECAUTION FOR USE

- (1) A limit sample should be provided by the both parties on an occasion when the both parties agreed its necessity. Judgement by a limit sample shall take effect after the limit sample has been established and confirmed by the both parties.
- (2) On the following occasions, the handling of the problem should be decided through discussion and agreement between responsible persons of the both parties.
- 1) When a question is arisen in the specifications.
 - 2) When a new problem is arisen which is not specified in this specifications.
 - 3) When an inspection specifications change or operating condition change in customer is reported to HITACHI, and some problem is arisen in this specification due to the change.
 - 4) When a new problem is arisen at the customer's operating set for sample evaluation in the customer site.

The precaution that should be observed when handling LCM have been explained above. If any point is unclear or if you have any request, please contact HITACHI.

KAOHSIUNG HITACHI ELECTRONICS CO.,LTD.	DATE	Apr.16,'04	Sh. No.	7B64PS 2713-SP14N003-3	PAGE	13-1/1
---	------	------------	------------	------------------------	------	--------