

DP & PC Series

Protects electronic equipment and systems against surges on signal and I/O cabling



- **Easy installation – simple DIN rail mounting**
- **Multistage hybrid protection circuitry – 10kA peak current capability**
- **Range of voltage ratings to suit all process I/O applications**
- **High bandwidth, low resistance and PSTN versions available**
- **10 year product warranty**



The DP & PC DIN Series of surge protection devices combines application versatility, proven reliable hybrid circuitry, and simple installation – features which make the range an ideal protection solution for process equipment, I/O systems and communications networks.

Sophisticated hybrid circuitry protects vulnerable equipment without affecting normal operation, passing ac or dc signals with little attenuation while diverting surge currents safely to earth and clamping output voltages to safe levels. The DP & PC DIN Series can prevent costly damage to equipment, system downtime and loss of production.

One simple manual operation clamps modules securely onto standard 'top-hat' (T-section) or 'G' type DIN rail. Where a number of DP or PC DIN modules are mounted on one rail, any that are incorrectly mounted are very obvious and can easily be remounted correctly.

Modules with a comprehensive range of voltage ratings cover all process related signals such as RTDs, THCs, 4-20mA loops, telemetry outstations, shutdown systems and fire and gas detectors. Industrial Bus system applications include Lonworks, Modbus plus, Modbus and Worldfip. DP DIN modules are suitable for general process I/O applications. However, where higher currents are required or loop resistance is critical, the PC DIN units are ideal.

Telecom applications are served by the DP DIN range which has been approved for use on telecom networks. Private wire installations can be protected using the standard DP DIN range while the DP200/D is designed for public switched telephone networks (PSTN).

Complete protection can be achieved using our wide range of mains power

devices to prevent surges entering equipment via their mains/power supply. Modules for I/O sub-systems, with working voltages up to 240V ac rms, are available in the form of the MA05/D, MA10/D and MA15/D which utilise the same compact enclosure as the DP and PC DIN range. These devices combine a high level of protection with the additional benefit of RFI filtering, thus removing noise and other unwanted signals from the supply.

A 10 year, unconditional product warranty is offered with the DP & PC DIN Series, like all Telematic surge protection devices.

Data & Signal Protection

Specification

All figures typical at 25°C (77°F) unless otherwise stated

Maximum surge current

10kA (8/20µs waveform)

Ambient temperature limits

-40°C to +80°C (-40°F to 176°F) - working
-40°C to +100°C (-40°F to 212°F) - storage

Humidity

5% to 95% RH (non-condensing)

Casing

Polyamide-PA with G- or T-section ('Top-hat')
DIN rail mounting foot

Connectors

Screw-clamp terminal

Terminals

2.5mm² (0.1 inch²)
12 AWG

Mounting

T-section ('Top-hat') or 35mm (1.4 inch) DIN rail

Weight

100g (3.53oz) approx.

Dimensions

See figure 1

EMC compliance

To Generic Immunity Standards
BS EN 50082, part 2 for industrial environments

R&TTE compliance

BS EN 50082-2: 1995
BS EN 41003: 1999

LVD compliance (DP200/D)

BS EN 41003: 1999

Installation

Figure 2 shows the installation for a typical control system. Each signal pair enters the system via a DIN rail mounted DP or PC Series surge protection device (SPD). A number of earth terminals may be used to simplify earthing.

Signal SPD earths are daisy-chained together using the 6.3mm spade terminals at the side of the units. A further link is taken from the outermost units to the earth terminals and forms a high integrity earth through the DIN rail.

As many as seven SPDs can be mounted in this way - further units will require additional earth terminals after every seven SPDs. Insulating spacers may be required to isolate this common surge earth from the system backplane.

The instrument rail should be bonded to the SPD earth rail and a short link taken from the SPD earth rail down to the local electrical earth bar. This method, with the addition of ac power protection, provides the maximum protection for a given installation.

To order specify -

Model number as per specification table above.

Note: In accordance with our policy of continuous improvement, Telematic reserves the right to change the product's specification without notice.

Model	Working voltage (V)	Rated load current (mA)	Nominal resistance per line (Ω)	Max. leakage current (µA)	Max. continuous operating voltage (V)	Limiting voltage (V)	Bandwidth
DP06/D	5.5	70	43	1000	6	30	220kHz
DP16/D	13.5	180	43	5	16	40	380kHz
DP30/D	25.5	340	43	5	30	60	500kHz
DP51/D	43.5	400	43	5	51	100	580kHz
DP75/D	64.0	400	43	5	75	150	600kHz
PC06/D	6	2A	1	2000	6	30	200kHz
PC16/D	15	2A	1	10	16	40	580kHz
PC30/D	27	2A	1	10	30	60	1.0MHz
PC51/D	47	2A	1	10	51	100	2.6MHz
DP200/D	180	N/A	5	10	200	250	10MHz

Definitions of terminology used in table

1 Working voltage

Maximum voltage between lines or lines/earth for the specified leakage current

2 Maximum leakage current

Maximum current drawn by the SPD at the working voltage

3 Maximum continuous operating voltage

Maximum voltage that can be applied to the protected terminals without damage

4 Limiting voltage

Peak output voltage after injection of test impulse from 6kV/3kA combination waveform generator (often known as 'let-through' voltage)

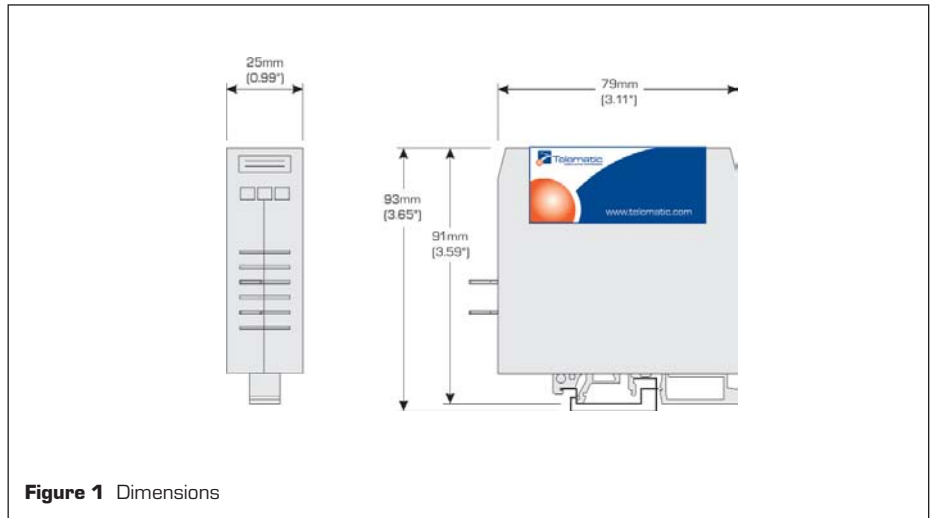

Figure 1 Dimensions

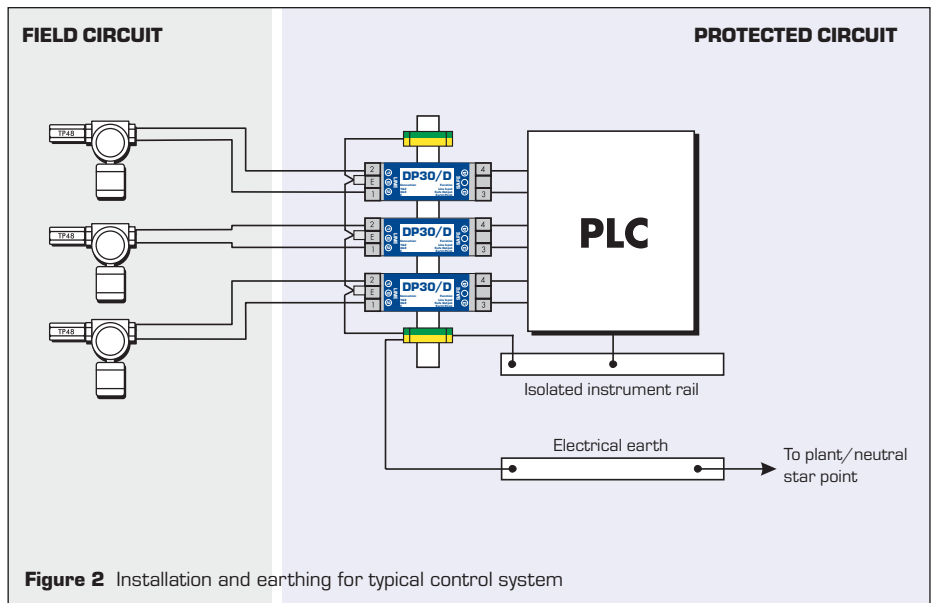

Figure 2 Installation and earthing for typical control system

MTL Surge Technologies

Power Court, Luton, Bedfordshire, England LU1 3JJ
Tel: +44 (0)1582 723633 Fax: +44 (0)1582 422283
E-mail: enquiry@mtlurge.com WWW: www.mtlurge.com

A member of the MTL Instruments Group plc

