

Molded SMD Power Inductor

ASPI-5050LR

Request Samples



Check Inventory



6.0 x 5.7 x 4.8 mm
RoHS/RoHS II Compliant
MSL Level = 1

Features

- Shielded construction
- Soft saturation
- Low DCR, High Efficiency
- Designed for switching frequencies between 100KHz-2MHz

Applications

- DC/DC Switching converters
- Power supplies for Notebooks, workstations, and Servers
- Low Profile applications
- High current, transient load applications
- Applications requiring extended temperature.

Electrical Specifications

Part Number	Inductance	Tolerance	DC Resistance	Saturation	Temperature
	0.1MHz/0.1V		Typ/Max	Current	Rise Current
Units	μ H	%	m Ω	A	A
Symbol	L	M	DCR	Isat	Irms
ASPI-5050LR-5R6	5.6	M	22.0 / 24.2	7.2	7.2
ASPI-5050LR-6R8	6.8	M	26.0 / 28.6	6.6	6.4
ASPI-5050LR-8R2	8.2	M	29.5 / 32.5	6.1	6.1
ASPI-5050LR-100	10	M	39.0 / 43.0	5.4	5.0
ASPI-5050LR-150	15	M	60.0 / 66.0	4.6	4.0
ASPI-5050LR-220	22	M	90.6 / 99.7	4.10	3.40

Test Conditions

Isat: DC current at which the inductance drops 30% from its value.

Irms: DC current that causes the temperature rise (ΔT , approximate 40 °C) from 20°C ambient

Operating Temperature: -40°C ~ +125°C (including self-temperature rise)

Storage Condition: -40°C ~ +125°C and R.H. 60 max

Operating Voltage: 15V (across inductor)

ASPI-5050LR Series is **RoHS Compliant and Pb free**

MSL level: 1



5101 Hidden Creek Ln Spicewood TX 78669
Phone: 512-371-6159 | Fax: 512-351-8858
For terms and conditions of sales, please visit:
www.abracon.com

REVISED: 06-28-21

ABRACON IS
ISO9001-2015
CERTIFIED

Molded SMD Power Inductor

ASPI-5050LR

Request Samples



Check Inventory



6.0 x 5.7 x 4.8 mm
RoHS/RoHS II Compliant
MSL Level = 1

Marking

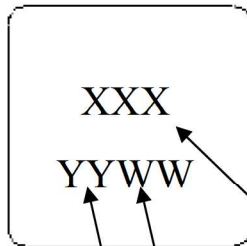

Inductance Code

e.g. 5R6

W: Week: E.g. 05 for the 5th week of the year.

Y: Year: E.g. 20 for 2020

Marking Method: Ink

Part Identification

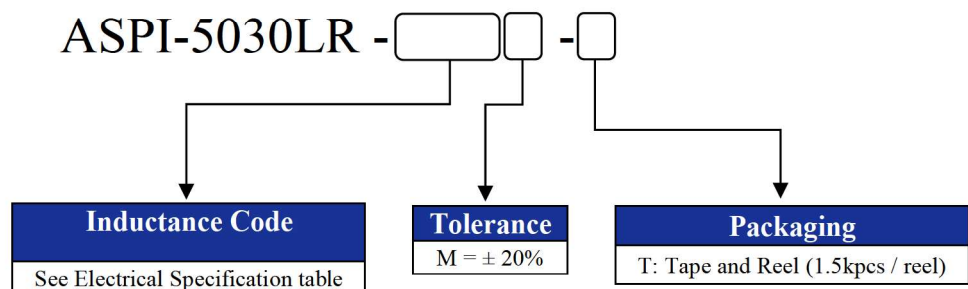

Molded SMD Power Inductor

ASPI-5050LR

Request Samples



Check Inventory



6.0 x 5.7 x 4.8 mm
 RoHS/RoHS II Compliant
 MSL Level = 1

Mechanical Dimensions

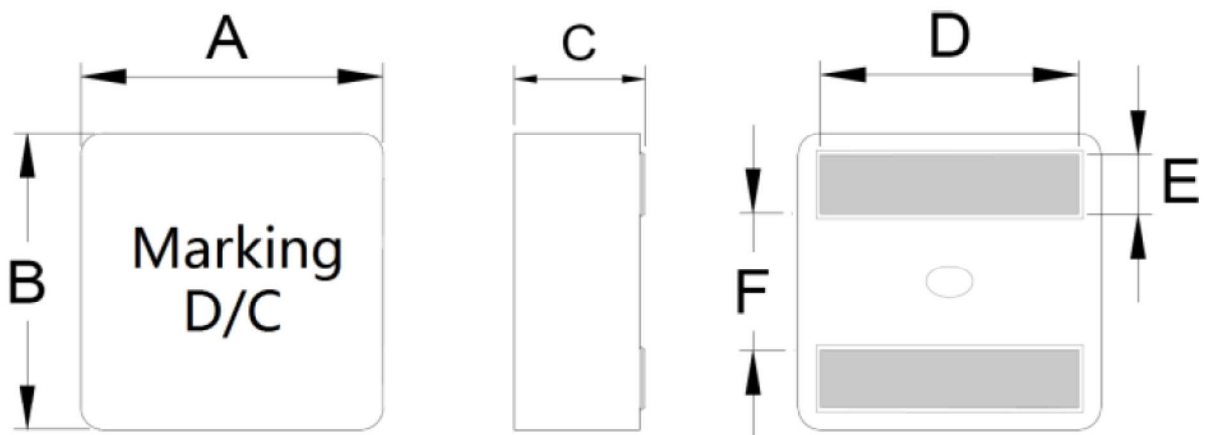

Series	A	B	C	D	E	F
ASPI-5050LR	6.0 ± 0.2	5.7 ± 0.2	4.8 ± 0.2	4.3 ± 0.3	1.1 ± 0.2	2.3 ± 0.25

Recommended Land Pattern

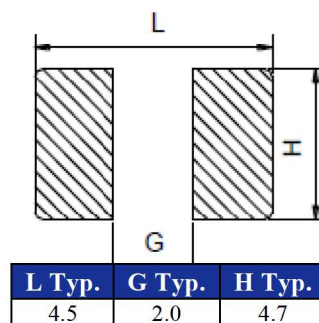

Dimensions: mm



5101 Hidden Creek Ln Spicewood TX 78669
 Phone: 512-371-6159 | Fax: 512-351-8858
 For terms and conditions of sales, please visit:
www.abracon.com

REVISED: 06-28-21

ABRACON IS
 ISO9001-2015
 CERTIFIED

Molded SMD Power Inductor

ASPI-5050LR

Request Samples



Check Inventory



6.0 x 5.7 x 4.8 mm
RoHS/RoHS II Compliant
MSL Level = 1

Materials

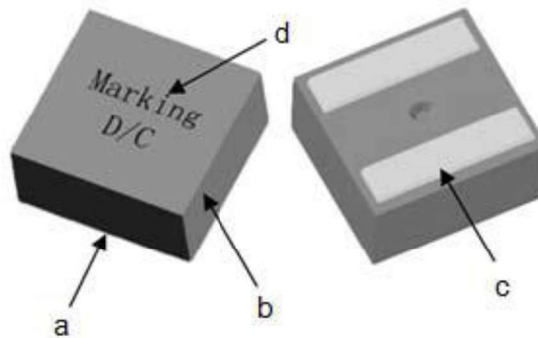

	Components	Material
a	Core	Alloy powder
b	Wire	220 deg. C Flat Wire
c	Solder	100% Pb free solder
d	Ink	Halogen-free ketone

Molded SMD Power Inductor

ASPI-5050LR

Request Samples



Check Inventory



6.0 x 5.7 x 4.8 mm
RoHS/RoHS II Compliant
MSL Level = 1

Reflow Profile

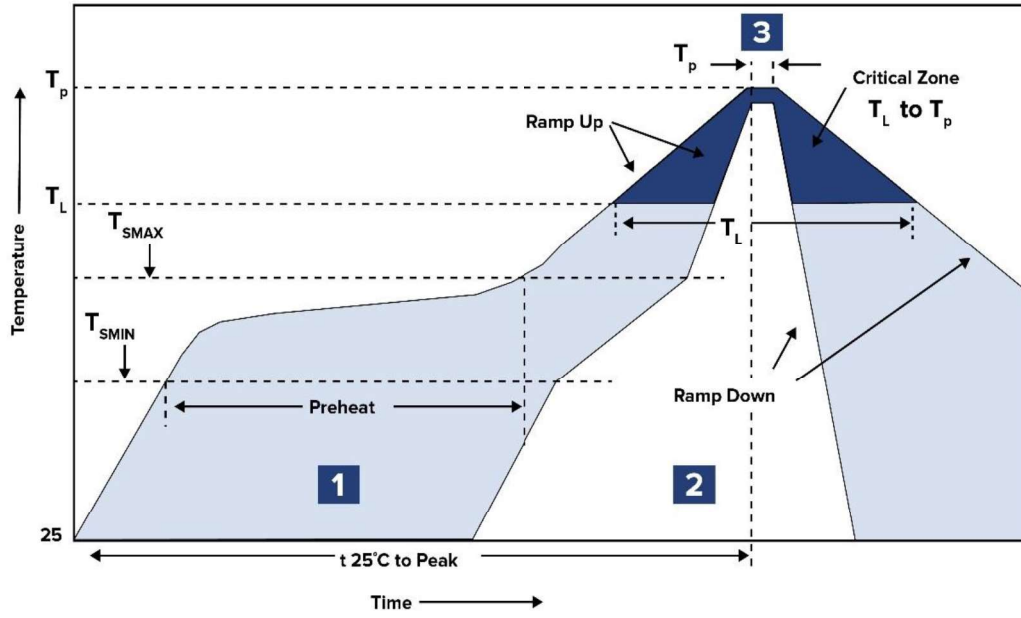

Zone	Description	Temperature	Times
1	Preheat	$T_{SMIN} \sim T_{SMAX}$ 150°C ~ 200°C	60 ~ 180 sec.
2	Reflow	T_L 217°C	60 ~ 150 sec.
3	Peak heat	T_P 260°C±5°C	10 sec. MAX

Molded SMD Power Inductor

ASPI-5050LR

Request Samples



Check Inventory



6.0 x 5.7 x 4.8 mm
RoHS/RoHS II Compliant
MSL Level = 1

Packaging

Tape & Reel: 1500 pcs/reel

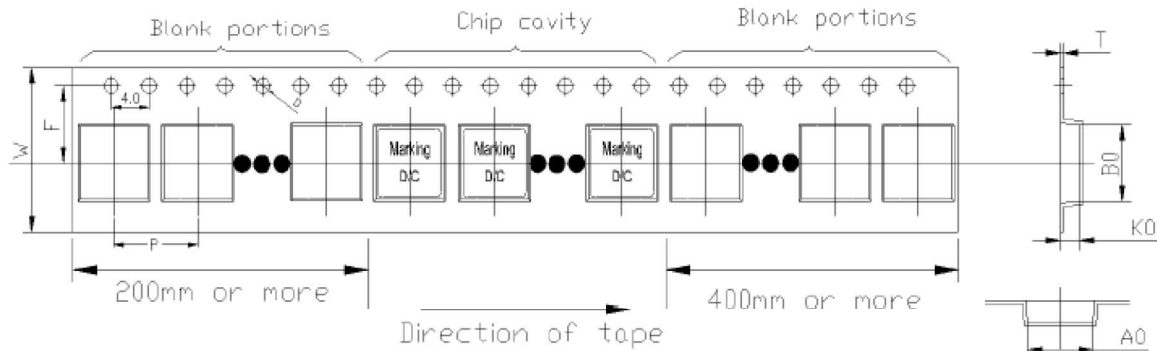

W	F	P	D	A ₀	B ₀	T	K ₀
16.0±0.3	7.5±0.1	8.0±0.1	1.5±0.1	6.4±0.1	6.1 ±0.1	0.35±0.05	5.3±0.1

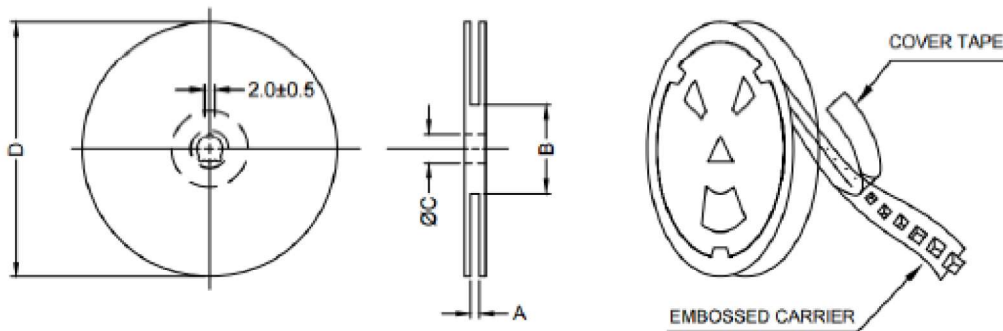

A	B	C	D
16.4+2/-0	100 ± 2	13.0+0.5/-0.2	330

Dimension: mm

ATTENTION: Abracon LLC's products are COTS – Commercial-Off-The-Shelf products; suitable for Commercial, Industrial and, where designated, Automotive Applications. Abracon's products are not specifically designed for Military, Aviation, Aerospace, Life-dependent Medical applications or any application requiring high reliability where component failure could result in loss of life and/or property. For applications requiring high reliability and/or presenting an extreme operating environment, written consent and authorization from Abracon LLC is required. Please contact Abracon LLC for more information.



5101 Hidden Creek Ln Spicewood TX 78669
 Phone: 512-371-6159 | Fax: 512-351-8858
 For terms and conditions of sales, please visit:
www.abracon.com

REVISED: 06-28-21

ABRACON IS
 ISO9001-2015
 CERTIFIED