

Spacer Bars

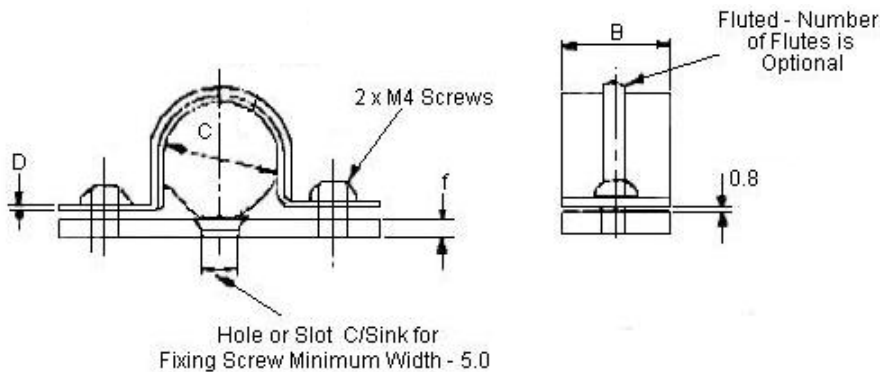

Features:

- Saddle tops shall be so designed as to permit assembly or removal with the screws in position.
- The base may be made of malleable case iron steel but if of dished section the minimum thickness must not be less than 1.09mm and the threaded holes shall provide a minimum engagement of 1 1/2 full threads.
- The base may exceed the dimensions A and B.
- Dimension B for 16mm size for keyhole pattern to be 17.5mm minimum.



Radii may be Greater than B/2

Some Designs may Require the Fixing Screws to be Offset

Example of Slotted Pattern

Example of Keyhole Pattern

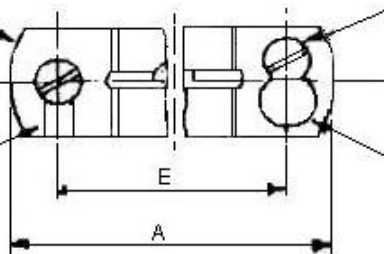

Dimensions : Millimetres

Specifications

Material	Nominal Size	Finish	A Minimum	B Minimum	C (Diameter)		D Minimum	E Nominal	F Minimum	Part Number
					Minimum	Maximum				
Steel	20	Black	55.0	19	20.0	20.4	0.87	39.0	3.0	20BSBS
	25		61.0		25.0	25.4		45.0	3.3	25BSBS
		Galvanized								25GSBS

Dimensions : Millimetres

Disclaimer This data sheet and its contents (the "Information") belong to the Premier Farnell Group (the "Group") or are licensed to it. No licence is granted for the use of it other than for information purposes in connection with the products to which it relates. No licence of any intellectual property rights is granted. The Information is subject to change without notice and replaces all data sheets previously supplied. The Information supplied is believed to be accurate but the Group assumes no responsibility for its accuracy or completeness, any error in or omission from it or for any use made of it. Users of this data sheet should check for themselves the Information and the suitability of the products for their purpose and not make any assumptions based on information included or omitted. Liability for loss or damage resulting from any reliance on the Information or use of it (including liability resulting from negligence or where the Group was aware of the possibility of such loss or damage arising) is excluded. This will not operate to limit or restrict the Group's liability for death or personal injury resulting from its negligence. SPC Multicomp is the registered trademark of the Group. © Premier Farnell plc 2009.

<http://www.farnell.com>
<http://www.newark.com>
<http://www.cpc.co.uk>

