

Sensors

Control and Communication

Electronic monitoring relays

Safety Relays

PNOZ X

PNOZsigma

PNOZelog

PNOZmulti

PNOZpower

Configurable control systems

Programmable safety and control systems

Industrial communication

Motion Control

Operating and Monitoring

Software

- [Back to overview](#)

PNOZsigma - Contact expansion

Safe monitoring of E-STOP, safety gate, light grid and two-hand control



PNOZ s7 24VDC 4 n/o 1 n/c
Order numbers: 750107

- Type: **PNOZ s7**
- Application options: **Instantaneous contact expansion**
- Category in accordance with: **EN 954-1 , EN ISO 13849-1**
- SIL value: --
- Approvals: **BG , CCC , GOST Russia , UL/cUL**
- Operating modes: **Without detection of shorts across contacts , Single-channel**
- Selectable times: --
- Number of instantaneous safety contacts: **4**
- Number of delayed safety contacts: --
- Number of auxiliary contacts: **1**
- Number of delayed auxiliary contacts: --
- Number of semiconductor outputs: --
- Stop category: --
- Supply voltage [V]: **24**
- Supply voltage range: --
- Supply voltage type: **DC**
- Max. current at DC1: **8,0 A**
- Power consumption AC: --
- Power consumption DC: --
- Terminal type: **Screw terminal**
- Terminal style: **Plug-in**
- Height dimension: **98,0 mm**
- Width dimension: **17,5 mm**
- Depth dimension: **120,0 mm**
- Height dimension (inches): **3.86"**
- Width dimension (inches): **0.69"**
- Depth dimension (inches): **4.72"**
- Gross weight: **225 g**
- Net weight: **170 g**
- Ambient temperature in °C: **-10 - 55 °C**

Up to PL e of EN ISO 13849-1 PNOZ s7



Contact expansion module for increasing the number of available contacts

Approvals

PNOZ s7	
	◆
	◆
	◆

Unit features

- ▶ Positive-guided relay outputs:
 - 4 safety contacts (N/O), instantaneous
 - 1 auxiliary contact (N/C), instantaneous
- ▶ Safe separation of safety contacts 13-14, 23-24, 33-34 from all other circuits
- ▶ LED indicator for:
 - Input status, channel 1
 - Input status, channel 2
 - Switch status of the safety contacts
 - Errors
- ▶ Plug-in connection terminals (either spring-loaded terminal or screw terminal)

Unit description

The unit meets the requirements of EN 60947-5-1, EN 60204-1 and VDE 0113-1. The contact expansion module is used to increase the number of instantaneous safety contacts available on a base unit. Base units are all safety relays with feedback loop monitoring.

The category that can be achieved in accordance with EN 954-1 and EN ISO 13849-1 depends on the category of the base unit. The contact expansion module may not exceed this.

Safety features

The unit meets the following safety requirements:

- ▶ The contact expansion module expands an existing circuit. As the output relays are monitored via the base unit's feedback loop, the safety functions on the existing circuit are transferred to the contact expansion module.
- ▶ The safety function remains effective in the case of a component failure.
- ▶ Earth fault in the feedback loop: Detected, depending on the base unit that is used.
- ▶ Earth fault in the input circuit: The output relays de-energise and the safety contacts open.

Block diagram

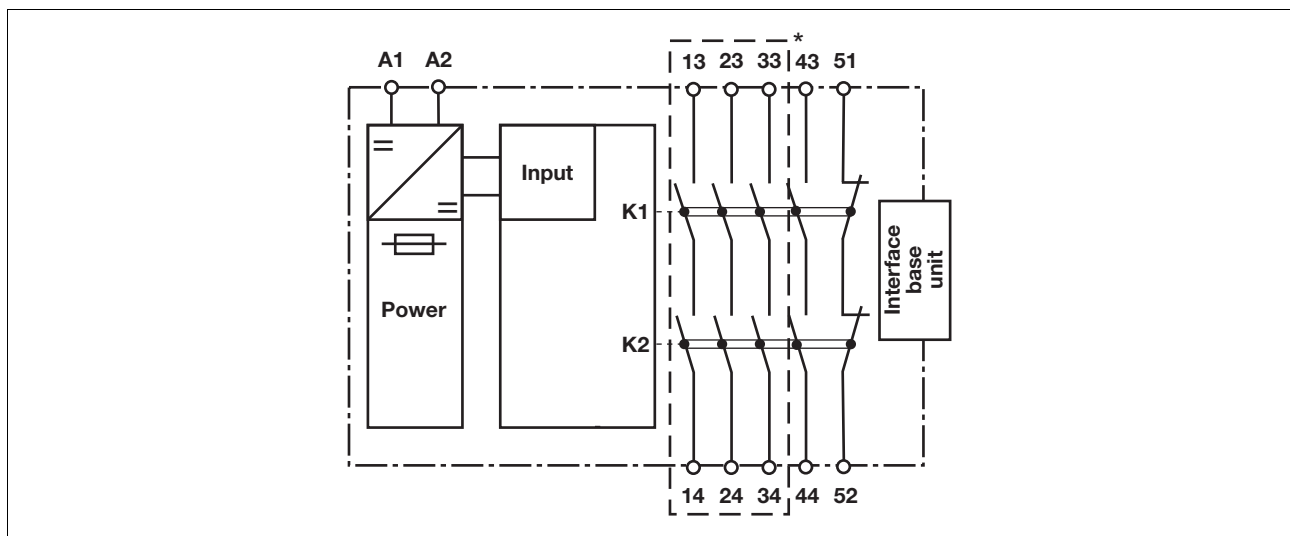

* Safe separation in accordance with EN 60947-1, 6 kV

Up to PL e of EN ISO 13849-1 PNOZ s7

Function description

with PNOZsigma base unit:

- ▶ Dual-channel operation via PNOZsigma connector

without PNOZsigma base unit:

- ▶ Single-channel operation: one input circuit affects the output relays

Timing diagram

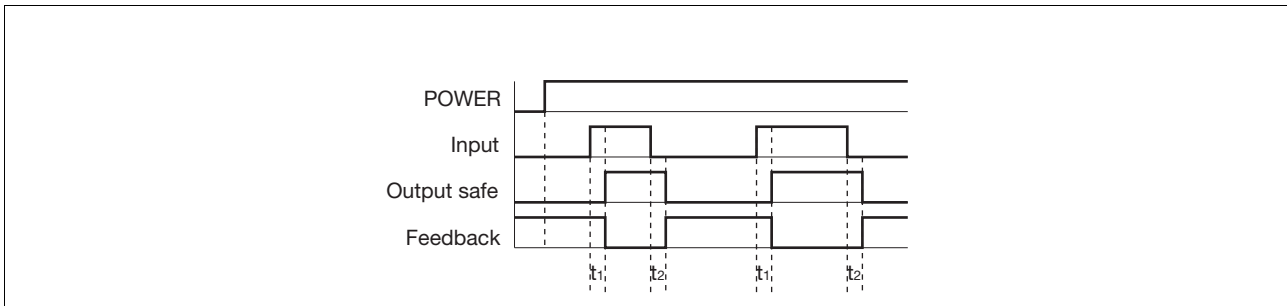

Key

- ▶ Power: Supply voltage
- ▶ Input: Input circuits A1
- ▶ Output safe: Safety contacts 13-14, 23-24, 33-34, 43-44
- ▶ Feedback: Feedback loop 51-52
- ▶ t_1 : Switch-on delay
- ▶ t_2 : Delay-on de-energisation

Wiring

Please note:

- ▶ Information given in the "Technical details" must be followed.
- ▶ Outputs 13-14, 23-24, 33-34, 43-44 are safety contacts, output 51-52 is an auxiliary contact (e.g. for display).
- ▶ To prevent contact welding, a fuse should be connected before the output contacts (see technical details).
- ▶ Calculation of the max. cable runs l_{max} in the input circuit:

$$l_{max} = \frac{R_{lmax}}{R_l / km}$$

R_{lmax} = max. overall cable resistance (see technical details)

R_l / km = cable resistance/km

- ▶ Use copper wire that can withstand 60/75 °C.
- ▶ Sufficient fuse protection must be provided on all output contacts with capacitive and inductive loads.

Up to PL e of EN ISO 13849-1 PNOZ s7

Preparing for operation

Supply voltage

Supply voltage	AC	DC

Input circuit

Input circuit	Single-channel	Dual-channel
Base unit: PNOZ X safety relay		
Base unit: PNOZelog safety relay Driven via semiconductor outputs (24 VDC)		

Feedback loop

Feedback loop	Base unit: Safety relay PNOZ X	Base unit: PNOZelog safety relay
Y1, Y2 and Input are inputs on the base unit; they evaluate the feedback loop		

Connection to PNOZsigma base unit

	Base unit: PNOZsigma safety relay
The feedback loop is connected and evaluated via the connector	

INFORMATION

If a base unit and a contact expander module from the PNOZsigma range

are connected via the connector, no additional wiring is necessary.

Do not connect A1 to the contact expander module!

Up to PL e of EN ISO 13849-1 PNOZ s7

Terminal configuration

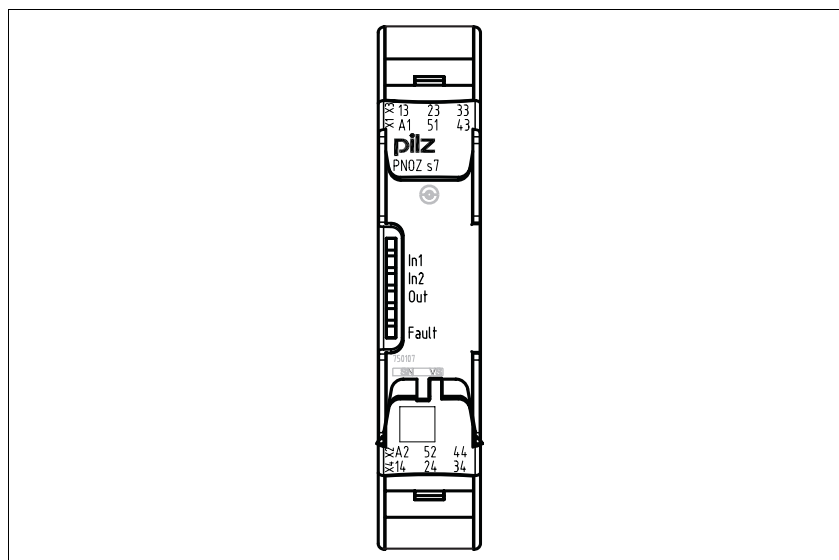

Installation

Install contact expander module without base unit:

- ▶ Ensure that the plug terminator is inserted at the side of the unit.

Connect base unit and PNOZsigma contact expander module:

- ▶ Remove the plug terminator at the side of the base unit and at the contact expander module
- ▶ Connect the base unit and the contact expander module to the supplied connector before mounting the units to the DIN rail.

Installation in control cabinet

- ▶ The safety relay should be installed in a control cabinet with a protection type of at least IP54.
- ▶ Use the notch on the rear of the unit to attach it to a DIN rail.
- ▶ Ensure the unit is mounted securely on a vertical DIN rail (35 mm) by using a fixing element (e.g. retaining bracket or an end angle).
- ▶ Push the unit upwards or downwards before lifting it from the DIN rail.

Dimensions

*with spring-loaded terminals

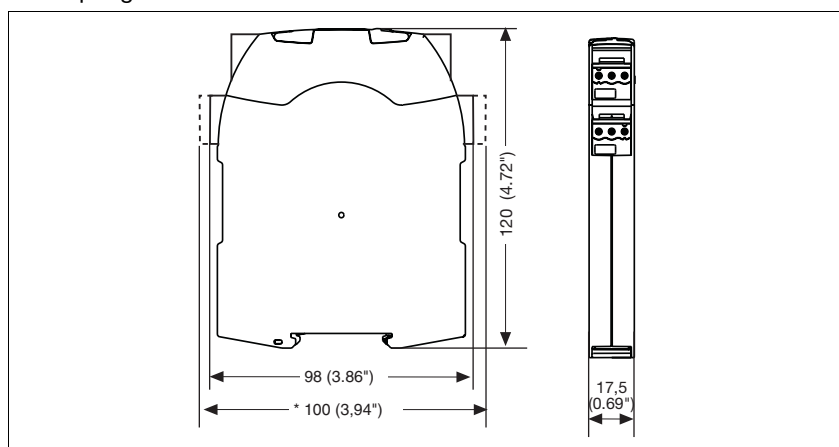

Up to PL e of EN ISO 13849-1 PNOZ s7

NOTICE

This data sheet is only intended for use during configuration. For installation and operation, please refer to the operating instructions supplied with the unit.

Service life graph

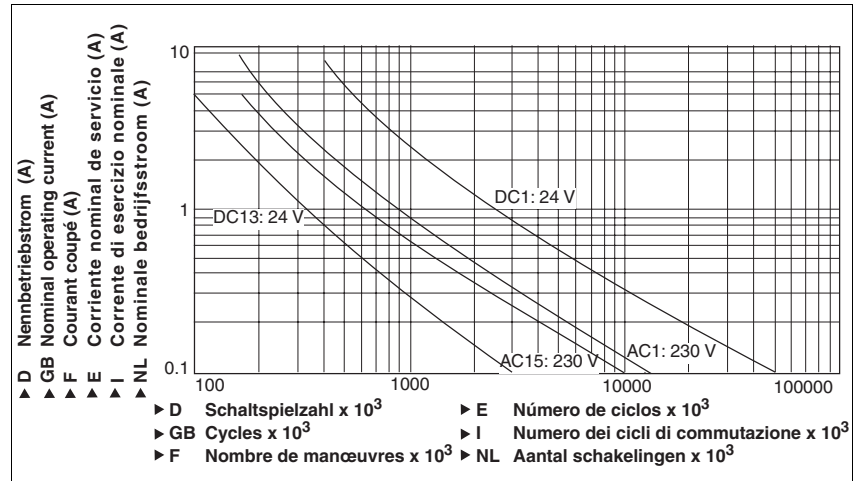

Technical details

Electrical data

Supply voltage	
Supply voltage U_B DC	24 V
Voltage tolerance	-20 %/+20 %
Power consumption at U_B DC	2.0 W
Residual ripple DC	20 %
Voltage and current at Input circuit DC: 24.0 V	70.0 mA
Number of output contacts	
Safety contacts (S) instantaneous:	4
Auxiliary contacts (N/C):	1
Utilisation category in accordance with EN 60947-4-1	
Safety contacts: AC1 at 240 V	$I_{min}: 0.01 A, I_{max}: 8.0 A$ $P_{max}: 2000 VA$
Safety contacts: DC1 at 24 V	$I_{min}: 0.01 A, I_{max}: 8.0 A$ $P_{max}: 200 W$
Auxiliary contacts: AC1 at 240 V	$I_{min}: 0.01 A, I_{max}: 2.0 A$ $P_{max}: 500 VA$
Auxiliary contacts: DC1 at 24 V	$I_{min}: 0.01 A, I_{max}: 2.0 A$ $P_{max}: 50 W$
Utilisation category in accordance with EN 60947-5-1	
Safety contacts: AC15 at 230 V	$I_{max}: 6.0 A$
Safety contacts: DC13 at 24 V (6 cycles/min)	$I_{max}: 5.0 A$
Auxiliary contacts: AC15 at 230 V	$I_{max}: 2.0 A$
Auxiliary contacts: DC13 at 24 V (6 cycles/min)	$I_{max}: 2.0 A$
Contact material	AgCuNi + 0.2 µm Au
External contact fuse protection ($I_k = 1 kA$) to EN 60947-5-1	
Blow-out fuse, quick	
Safety contacts:	10 A
Auxiliary contacts:	4 A
Blow-out fuse, slow	
Safety contacts:	6 A
Auxiliary contacts:	2 A
Circuit breaker 24 VAC/DC, characteristic B/C	
Safety contacts:	6 A
Auxiliary contacts:	2 A

Up to PL e of EN ISO 13849-1 PNOZ s7

Electrical data	
Max. overall cable resistance R_{lmax} input circuits, reset circuits single-channel at U_B DC	30 Ohm
Safety-related characteristic data	
Performance level (PL) in accordance with EN ISO 13849-1	
Safety contacts, instantaneous	e
Category of output contacts in accordance with EN 954-1 , EN ISO 13849-1	
Safety contacts (S) instantaneous:	4
SIL claim limit (SIL CL) in accordance with EN IEC 62061	
Safety contacts, instantaneous	3
Probability of dangerous failure per hour (PFH_D) in accordance with EN IEC 62061	
Safety contacts, instantaneous	2.31E-09 1/h
Mission time/Proof test interval in years	20
Times	
Switch-on delay	
with automatic reset after power on typ.	30 ms
with automatic reset after power on max.	50 ms
Delay-on de-energisation	
with E-STOP typ.	18 ms
with E-STOP max.	30 ms
with power failure typ.	18 ms
with power failure max.	30 ms
Environmental data	
EMC	EN 60947-5-1, EN 61000-6-2, EN 61000-6-4
Vibration to EN 60068-2-6	
Frequency	10 - 55 Hz
Amplitude	0.35 mm
Climatic suitability	EN 60068-2-78
Airgap creepage in accordance with EN 60947-1	
Pollution degree	2
Rated insulation voltage	250 V
Rated impulse withstand voltage	6.0 kV
Ambient temperature	-10 - 55 °C
Storage temperature	-40 - 85 °C
Protection type	
Mounting (e.g. cabinet)	IP54
Housing	IP40
Terminals	IP20
Mechanical data	
Housing material	
Housing	PC
Front	PC
Cross section of external conductors with screw terminals	
1 core flexible	0.25 - 2.50 mm ² , 24 - 12 AWG Order no.: 750107
2 core, same cross section, flexible:	
with crimp connectors, without insulating sleeve	0.25 - 1.00 mm ² , 24 - 16 AWG Order no.: 750107
without crimp connectors or with TWIN crimp connectors	0.20 - 1.50 mm ² , 24 - 16 AWG Order no.: 750107
Torque setting with screw terminals	0.50 Nm Order no.: 750107
Cross section of external conductors with spring-loaded terminals: Flexible with/without crimp connectors	
Spring-loaded terminals: Terminal points per connection	2 Order no.: 751107
Stripping length	9 mm Order no.: 751107

Up to PL e of EN ISO 13849-1 PNOZ s7

Mechanical data

Dimensions	
Height	102.0 mm Order no.: 751107 98.0 mm Order no.: 750107
Width	17.5 mm
Depth	120.0 mm
Weight	170 g

The standards current on **2006-04** apply.

Conventional thermal current

I_{th} (A) at U_B DC

1 contact	8.00 A
2 contacts	5.50 A
3 contacts	4.50 A
4 contacts	4.00 A

Order reference

Type	Features	Terminals	Order no.
PNOZ s7	24 VDC	With screw terminal	750 107
PNOZ s7 C	24 VDC	With spring-loaded terminal	751 107
PNOZ s7 C (coated version)	24 V DC	With spring-loaded terminal	751 187