

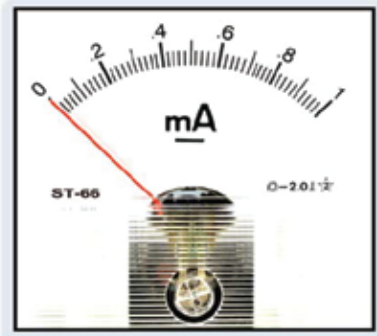

Model HST-66

Analog Panel Meters



HST-66 2.5"

Features

Case and Composition: Acrylic resin front and ABS resin case.
Four studs mounting.

Accuracy: Moving coil type: Class 2.0
Rectifier: Class 2.0

Color: Black case and white scale plate.
Pointer: Tube type, color in black or red.

Measuring Ranges

Moving Coil Type

DC uA	DCmA	DC A	DC mV	DC V
50	1	1	50	3
100	5	5	60	5
150	10	10	100	10
200	50	15	500	30
300	100			50
500	150			100
800	200			150
	300			200
	500			300
	800			500
				600

Rectifier Type

AC V
30
50
100
150
200
300
500

■ Consult Hoyt for other measuring ranges and scales

Dimensions

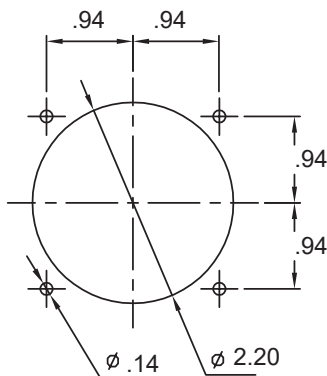

PANEL CUT-OUT

