

PREPARED BY: DATE	<p style="text-align: center;">SHARP[®]</p> <p style="text-align: center;">MOBILE LIQUID CRYSTAL DISPLAY GROUP SHARP CORPORATION</p> <p style="text-align: center;">SPECIFICATION</p>	SPEC No. LCY-W-07201A
APPROVED BY: DATE		FILE No.
		ISSUE Mar.7.2007
		PAGE Pages 29 APPLICABLE DIVISION MOBILE LCD CHINA DESIGN CENTER WUXI SHARP

DEVICE SPECIFICATION for
 TFT LCD Module
 (320 × RGB × 240 dots)

 Model No.
LQ035Q1DH01

CUSTOMER'S APPROVAL

DATE _____

BY _____

PRESENTED BY *K. Yamamoto*

YAMAMOTO.KUNIIHIKO

GENERAL MANAGER
 MOBILE LCD CHINA DESIGN CENTER
 WUXI SHARP

NOTICE

This publication is the proprietary of SHARP and is copyrighted, with all rights reserved. Under the copyright laws, no part of this publication may be reproduced or transmitted in any form or by any means, electronic or mechanical for any purpose, in whole or in part, without the express written permission of SHARP. Express written permission is also required before any use of this publication may be made by a third party.

The application circuit examples in this publication are provided to explain the representative applications of SHARP's devices and are not intended to guarantee any circuit design or permit any industrial property right or other rights to be executed. SHARP takes no responsibility for any problems related to any industrial property right or a third party resulting from the use of SHARP's devices, except for those resulting directly from device manufacturing processes.

In the absence of confirmation by device specification sheets, SHARP takes no responsibility for any defects that occur in equipment using any of SHARP's devices, shown in catalogs, data books, etc. Contact SHARP in order to obtain the latest device specification sheets before using any SHARP's device.

SHARP reserves the right to make changes in the specifications, characteristics, data, materials, structures and other contents described herein at any time without notice in order to improve design or reliability. Contact SHARP in order to obtain the latest specification sheets before using any SHARP's device. Manufacturing locations are also subject to change without notice.

Observe the following points when using any device in this publication. SHARP takes no responsibility for damage caused by improper use of the devices.

The devices in this publication are designed for use in general electronic equipment designs, such as:

- Personal computers • Office automation • Telecommunication equipment
- Test and measurement equipment • Industrial control • Personal Digital Assistant
- Audio visual and multimedia equipment • Consumer electronics

The appropriate design measures should be taken to ensure reliability and safety when SHARP's devices are used for equipment such as:

- Transportation control and safety equipment(i.e. aircraft, trains, automobiles, etc.)
- Traffic signals • Gas leakage sensor breakers
- Alarm equipment • Various safety devices etc.

SHARP's devices shall not be used for equipment that requires extremely high level of reliability, such as:

- Military and space applications • Nuclear power control equipment
- Medical equipment for life support

Contact a SHARP representative, in advance, when intending to use SHARP's devices for any "specific" applications other than those recommended by SHARP.

Contact and consult with a SHARP representative if there are any questions about the contents of this publication.

1. Applicable Scope

This specification is applicable to TFT-LCD Module “LQ035Q1DH01”.

2. General Description

This module is a color active matrix LCD module incorporating amorphous silicon TFT (Thin Film Transistor). It is composed of a color TFT-LCD panel, driver IC, Input FPC, a back light unit and a touch panel. Graphics and texts can be displayed on a 320 × RGB × 240 dots panel with about 262k colors by supplying 18bit data signals (6bit × RGB), four timing signals, 3wires 9bit serial interface signals, logic (Typ. +3.3V), analog (Typ. +3.3V) supply voltages for TFT-LCD panel driving and supply voltage for back light.

3. Mechanical (Physical) Specifications

Item	Specifications	Unit
Screen size	8.8 (3.5" type) diagonal	cm
Active area	70.56 (H) × 52.92 (V)	mm
Pixel format	320 (H) × 240 (V)	pixel
	1 Pixel = R+G+B dots	-
Pixel pitch	0.2205 (H) × 0.2205 (V)	mm
Pixel configuration	R,G,B vertical stripes	-
Display mode	Normally white	-
Unit outline dimensions *	63.9 (W) × 76.9 (H) × 4.5 (D)	mm
Mass	Approx. 43	g
Surface hardness	2H	-
Surface treatment	Anti glare	-

*The above-mentioned table indicates module sizes without some projections and FPC. For detailed measurements and tolerances, please refer to 19. Outline Dimensions.

4. Input Terminal Names and Functions

Recommendation CN : [HIROSE] FH26G-67S-0.3SHBW(05) or [KYOCERA ELCO] 00 6281 067 2X2 829 +

Pin No.	Symbol	I/O	Description	Remarks
1	LED_C (-)	-	Power supply for LED (Low voltage)	
2	LED_A(+)	-	Power supply for LED (High voltage)	
3	DGND1	-	Digital Ground	
4	X1	O	Touch Panel Right Electrode	
5	Y2	O	Touch Panel Bottom Electrode	
6	X2	O	Touch Panel Left Electrode	
7	Y1	O	Touch Panel Top Electrode	
8	AGND1	-	Analog Ground	
9	V _{GH}	-	Connect to a Stabilizing capacitor	Note 4
10	C2P	-	Connect a Booster capacitor to C2N	Note 3
11	C2N	-	Connect a Booster capacitor to C2P	Note 3
12	C1P	-	Connect a Booster capacitor to C1N	Note 3
13	C1N	-	Connect a Booster capacitor to C1P	Note 3
14	V _{GL}	-	Connect a Stabilizing capacitor to GND	Note 4
15	C3P	-	Connect a Booster capacitor to C3N	Note 3
16	C3N	-	Connect a Booster capacitor to C3P	Note 3
17	AGND2	-	Analog Ground	
18	V _{CIX2}	-	Connect a Stabilizing capacitor to GND	Note 4
19	CYP	-	Connect a Booster capacitor to CYN	Note 3
20	CYN	-	Connect a Booster capacitor to CYP	Note 3
21	V _{CI}	-	Booster input voltage pin	Note 4
22	NC	-	Not connected	Note 1
23	AGND3	-	Analog Ground	
24	V _{CIM}	-	Connect a Stabilizing capacitor to GND	Note 4
25	CXP	-	Connect a Booster capacitor to CXN	Note 3
26	CXN	-	Connect a Booster capacitor to CXP	Note 3
27	ID	O	MFG ID pin	Note 2
28	RESB	I	System reset	
29	DGND2	-	Digital Ground	
30	V _{DDIO}	-	Voltage input pin for logic I/O	
31	V _{CORE}	-	Connect a Stabilizing capacitor to GND	Note 4
32	DGND3	-	Digital Ground	
33	SHUT	I	Sleep mode control	
34	CSB	I	Chip select pin of serial interface	
35	SDI	I	Data input pin in serial mode	
36	SCK	I	Clock input pin in serial mode	
37	V _{DROP}	-	Connect a Stabilizing capacitor	
38	DEN	I	Display enable	
39	B5	I	BLUE data signal(MSB)	
40	B4	I	BLUE data signal	
41	B3	I	BLUE data signal	

Pin No.	Symbol	I/O	Description	Remarks
42	B2	I	BLUE data signal	
43	B1	I	BLUE data signal	
44	B0	I	BLUE data signal(LSB)	
45	G5	I	GREEN data signal(MSB)	
46	G4	I	GREEN data signal	
47	G3	I	GREEN data signal	
48	G2	I	GREEN data signal	
49	G1	I	GREEN data signal	
50	G0	I	GREEN data signal(LSB)	
51	R5	I	RED data signal(MSB)	
52	R4	I	RED data signal	
53	R3	I	RED data signal	
54	R2	I	RED data signal	
55	R1	I	RED data signal	
56	R0	I	RED data signal(LSB)	
57	VSYNC	I	Frame synchronization signal	
58	HSYNC	I	Line synchronization signal	
59	DOTCLK	I	Dot-clock signal	
60	CDUM0	-	Connect a Stabilizing capacitor to GND	Note 4
61	DGND4	-	Digital Ground	
62	V _{LCD63}	-	Connect a Stabilizing capacitor to GND	Note 4
63	V _{COMH}	-	Connect a Stabilizing capacitor to GND	Note 4
64	V _{COML}	-	Connect a Stabilizing capacitor to GND	Note 4
65	DGND5	-	Digital Ground	
66	CSVCMN	-	Connect a Stabilizing capacitor to CSVCMN	Note 4
67	CSVCMN	-	Connect a Stabilizing capacitor to CSVCMN	Note 4

Note 1) this pin should be opened.

Note 2) ID is connected to V_{DDIO} via FPC.

Note 3) Booster Capacitors

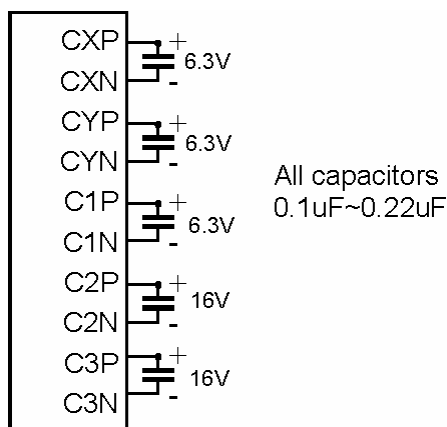

Note 4) Stabilization and charge sharing Capacitors

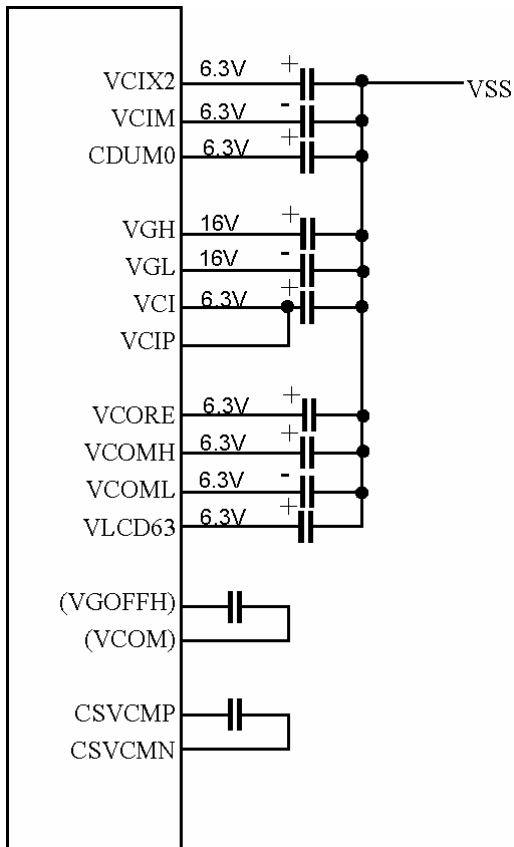

Mandatory requirement on external components for SSD2116 is 16 capacitors.

V_{CIX2} , V_{CIM} , $CDUM0$, V_{GH} , V_{GL} , V_{CL} , V_{CORE} , V_{COMH} , V_{COML} , V_{LCD63} , $CSVCMN/CSVCMN$, $C1P/C1N$, $C2P/C2N$, $C3P/C3N$, CYP/CYN , CXP/CXN

Remark:

Capacitor for $V_{CIX2G}/V_{CIX2} = 2.2\mu F$

All other capacitors $1.0\mu F \sim 2.2\mu F$ (2.2 μF is preferred for better display quality and power consumption.)

(Optional capacitors)

Capacitors on V_{GOFFHL}/V_{COM} are only for Cs on gate application

5. Absolute Maximum Ratings

Item	Symbol	Conditions	Rated value	Unit	Remarks
Input voltage	VI	Ta = 25°C	-0.3 ~ V _{DDIO} +0.3	V	Note 1
Logic I/O power supply voltage	V _{DDIO}	Ta = 25°C	-0.3 ~ +4.0	V	
Analog power supply voltage	V _{CI}	Ta = 25°C	AGND-0.3 ~ +5.0	V	
Temperature for storage	T _{stg}	-	-30 ~ +85	°C	Note 2
Temperature for operation	T _{opr}	-	-10 ~ +70	°C	Note 3
LED input electric current	I _{LED}	Ta = 25°C	35	mA	
LED electricity consumption	P _{LED}	Ta = 25°C	123	mW	

Note 1) RESB, SHUT, CSB, SDI, SCK, DEN, B5~B0, G5~G0, R5~R0, VSYNC, HSYNC, DOTCLK

Note 2) Humidity: 80%RH Max. (Ta ≤ 40°C)

Maximum bulb temperature under 39°C (Ta > 40°C) See to it that no dew will be condensed.

Note 3) Panel surface temperature prescribes.

(Reliability is examined at ambient temperature of 50°C.)

Note 4) Power consumption of one LED (Ta = 25°C). (use 7 pieces LED)

Ambient temperature and the maximum input are fulfilling the following operating conditions.

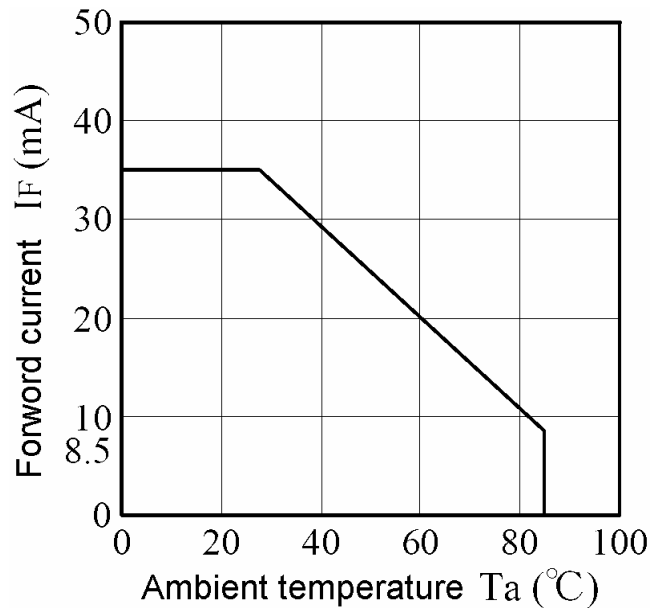

Ambient temperature and the maximum input

6. Electrical Characteristics
 6-1. TFT LCD Panel Driving

Ta = 25°C

Item		Symbol	Min.	Typ.	Max.	Unit	Remarks
Logic I/O power supply	DC voltage	V _{DDIO}	+2.5	+3.3	+3.6	V	
	DC Current	I _{VDDIO}	-	0.35	0.50	mA	Note 1
Analog power supply	DC voltage	V _{CI}	+2.5 or V _{DDIO}	+3.3	+3.6	V	
	DC Current	I _{VCI}	-	8.5	12.0	mA	Note 1
Permissive input Ripple voltage		V _{RFVDDIO}	-	-	(100)	mVp-p	Note 2
		V _{RFVCI}	-	-	(100)	mVp-p	Note 2
Logic Input Voltage	High	V _{IH}	0.8 V _{DDIO}	-	V _{DDIO}	V	Note 3
	Low	V _{IL}	0	-	0.2 V _{DDIO}	V	Note 3
Logic input Current		I _{IH} / I _{IL}	-1	-	1	μA	Note 3

Note 1) V_{DDIO} = V_{CI} = +3.3V
 Current situation for I_{VDDIO}: Black & White checker flag pattern
 Current situation for I_{CI}: All black pattern

Note 2) V_{DDIO} = V_{CI} = +3.3V

Note 3) RESB, SHUT, CSB, SDI, SCK, DEN, B5~B0, G5~G0, R5~R0, VSYNC, HSYNC, DOTCLK

6-2. Register Setting

Reg. #	Register	Data (Gamma 2.2)	Remark
R01 h	Driver output control	2AEF h	
R02 h	LCD drive AC control	0300 h	
R03 h	Power control (1)	7A7E h	
R0B h	Frame cycle control	DC00 h	
R0C h	Power control (2)	0005 h	
R0D h	Power control (3)	0002 h	
R0E h	Power control (4)	2900 h	
R0F h	Gate scan starting Position	0000 h	
R16 h	Horizontal Porch	9F86 h	Note1
R17 h	Vertical Porch	0002 h	Note2
R1E h	Power control (5)	0000 h	
R2E h	3 Gamma	B945 h	
R30 h	Gamma control (1)	0000 h	
R31 h	Gamma control (1)	0707 h	
R32 h	Gamma control (1)	0003 h	
R33 h	Gamma control (1)	0401 h	
R34 h	Gamma control (1)	0307 h	
R35 h	Gamma control (1)	0000 h	
R36 h	Gamma control (1)	0707 h	
R37 h	Gamma control (1)	0204 h	
R3A h	Gamma control (2)	0D0B h	
R3B h	Gamma control (2)	0D0B h	
R40 h	Gamma control (3)	0000 h	
R41 h	Gamma control (3)	0707 h	
R42 h	Gamma control (3)	0003 h	
R43 h	Gamma control (3)	0401 h	
R44 h	Gamma control (3)	0307 h	
R45 h	Gamma control (3)	0000 h	
R46 h	Gamma control (3)	0707 h	
R47 h	Gamma control (3)	0204 h	
R4A h	Gamma control (4)	0D0B h	
R4B h	Gamma control (4)	0D0B h	
R50 h	Gamma control (5)	0000 h	
R51 h	Gamma control (5)	0707 h	
R52 h	Gamma control (5)	0003 h	
R53 h	Gamma control (5)	0401 h	
R54 h	Gamma control (5)	0307 h	
R55 h	Gamma control (5)	0000 h	
R56 h	Gamma control (5)	0707 h	
R57 h	Gamma control (5)	0204 h	
R5A h	Gamma control (6)	0D0B h	
R5B h	Gamma control (6)	0D0B h	

Note 1)

Horizontal Porch (R16h) (POR = 9F86h)

R/W	DC	IB15	IB14	IB13	IB12	IB11	IB10	IB9	IB8	IB7	IB6	IB5	IB4	IB3	IB2	IB1	IB0
W	1	XL8	XL7	XL6	XL5	XL4	XL3	XL2	XL1	XL0	0	HBP5	HBP4	HBP3	HBP2	HBP1	HBP0
POR	1	1	0	0	1	1	1	1	1	1	0	0	0	0	1	1	0

XL7-0: Set the number of valid pixel per line.

XL8	XL7	XL6	XL5	XL4	XL3	XL2	XL1	XL0	No. of pixel per line
0	0	0	0	0	0	0	0	0	1
0	0	0	0	0	0	0	0	1	2
0	0	0	0	0	0	0	1	0	3
									:
									Step = 1
									:
1	0	0	1	1	1	1	1	0	319
1	0	0	1	1	1	1	1	1	320
1	0	1	*	*	*	*	*	*	Reserved
1	1	*	*	*	*	*	*	*	Reserved

HBP5-0: Set the delay period from falling edge of HSYNC signal to first valid data. The pixel data exceed the range set by XL8-0 and before the first valid data will be treated as dummy data.

HBP5	HBP4	HBP3	HBP2	HBP1	HBP0	No. of clock cycle of DOTCLK
0	0	0	0	0	0	2
0	0	0	0	0	1	3
0	0	0	0	1	0	4
0	0	0	0	1	1	5
0	0	0	1	0	0	6
0	0	0	1	0	1	7
0	0	0	1	1	0	8
0	0	0	1	1	1	9
0	0	1	0	0	0	10
						:
						Step = 1
						:
1	1	1	1	1	0	64
1	1	1	1	1	1	65

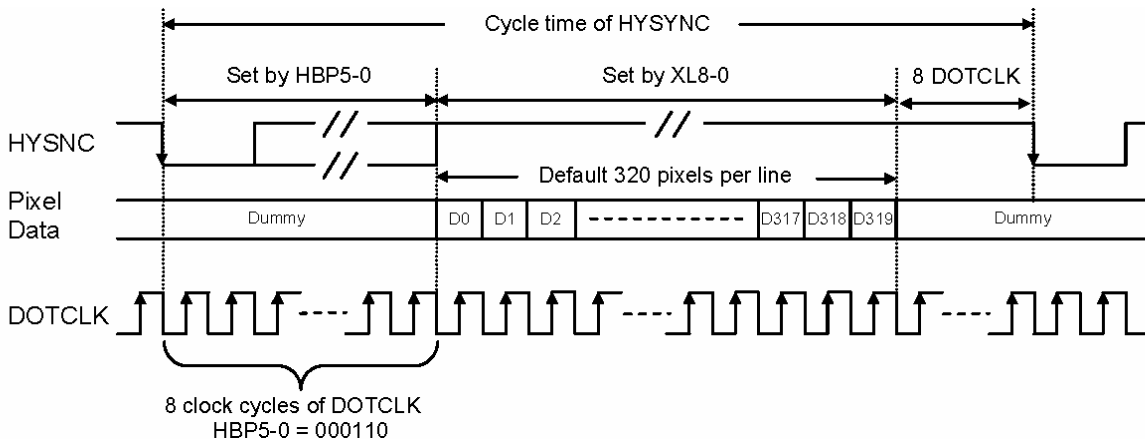

Note 2)

Vertical Porch (R17h) (POR = 0002h)

R/W	DC	IB15	IB14	IB13	IB12	IB11	IB10	IB9	IB8	IB7	IB6	IB5	IB4	IB3	IB2	IB1	IB0
W	1	0	0	0	0	0	0	0	VBP8	VBP7	VBP6	VBP5	VBP4	VBP3	VBP2	VBP1	VBP0
POR		0	0	0	0	0	0	0	0	0	0	0	0	0	0	1	0

VBP7-0: Set the delay period from falling edge of VSYNC to first valid line. The line data within this delay period will be treated as dummy line.

VBP8	VBP7	VBP6	VBP5	VBP4	VBP3	VBP2	VBP1	VBP0	No. of clock cycle of HSYNC
0	0	0	0	0	0	0	0	0	0 (only allow when CAD=0)
0	0	0	0	0	0	0	0	1	1
0	0	0	0	0	0	0	1	0	2
0	0	0	0	0	0	0	1	1	3
0	0	0	0	0	0	1	0	0	4
⋮									⋮
⋮									Step = 1
⋮									⋮
1	0	0	1	1	1	1	1	0	319
1	0	0	1	1	1	1	1	1	320
1	0	1	*	*	*	*	*	*	Reserved
1	1	*	*	*	*	*	*	*	Reserved

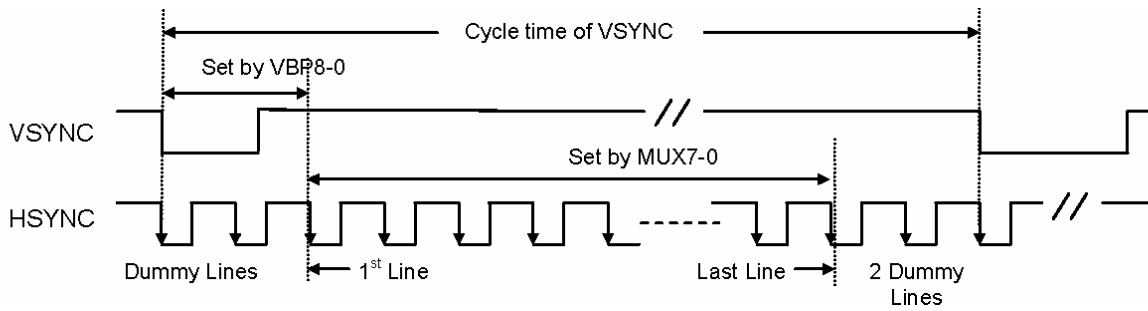

6-3. Back light driving

The back light system has 7 LEDs

[NSSW020B]

Parameter	Symbol	Min.	Typ.	Max.	Unit	Remark
Rated Voltage	V _{BL}	-	22.4	24.5	V	
Rated Current	I _L	-	20	-	mA	Ta=25°C
Power consumption	W _L	-	448	-	mW	

7. Timing characteristics of input signals

7-1. Pixel Clock Timing

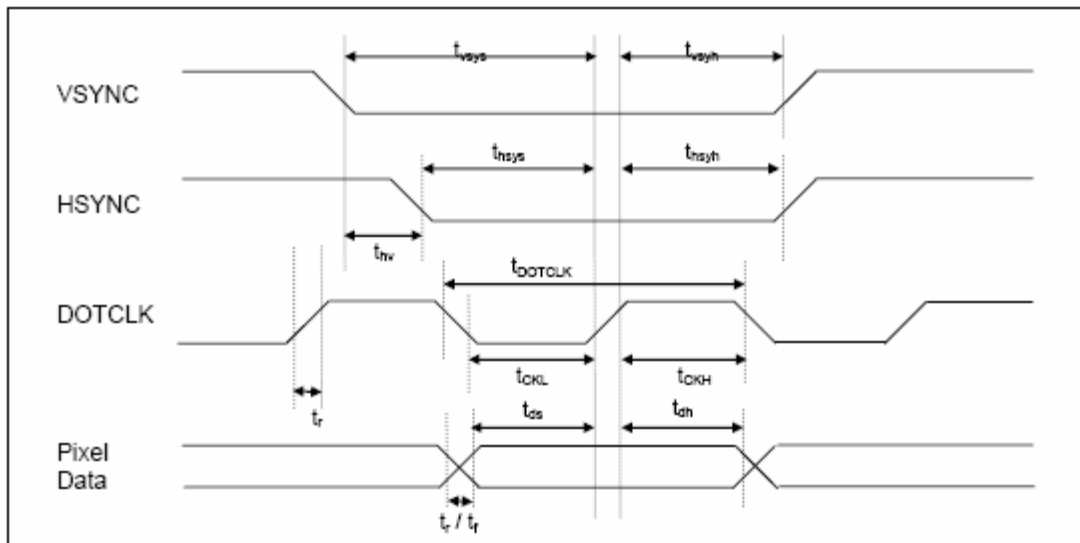

Pixel Clock Timing

Characteristics	Symbol	Min	Typ	Max	Units
DOTCLK Frequency	f_{DOTCLK}	-	5.0	8.0	MHz
DOTCLK Period	t_{DOTCLK}	125	200	-	nSec
Vertical Sync Setup Time	t_{vsys}	20	-	-	nSec
Vertical Sync Hold Time	t_{vsh}	20	-	-	nSec
Horizontal Sync Setup Time	t_{hsys}	20	-	-	nSec
Horizontal Sync Hold Time	t_{hsh}	20	-	-	nSec
Phase difference of Sync Signal Falling Edge	t_{nv}	0	-	320	t_{DOTCLK}
DOTCLK Low Period	t_{CKL}	62	-	-	nSec
DOTCLK High Period	t_{CKH}	62	-	-	nSec
Data Setup Time	t_{ds}	40	-	-	nSec
Data hold Time	t_{dh}	40	-	-	nSec
Reset pulse width	t_{RES}	10	-	-	uSec
Rise / Fall time	t_r / t_f	20	-	100	nSec

Note: External clock source must be provided to DOTCLK pin of SSD2116Z. The driver will not operate if absent of the clocking signal.

7-2. Data Transaction Timing in Normal Operating Mode (262k color)

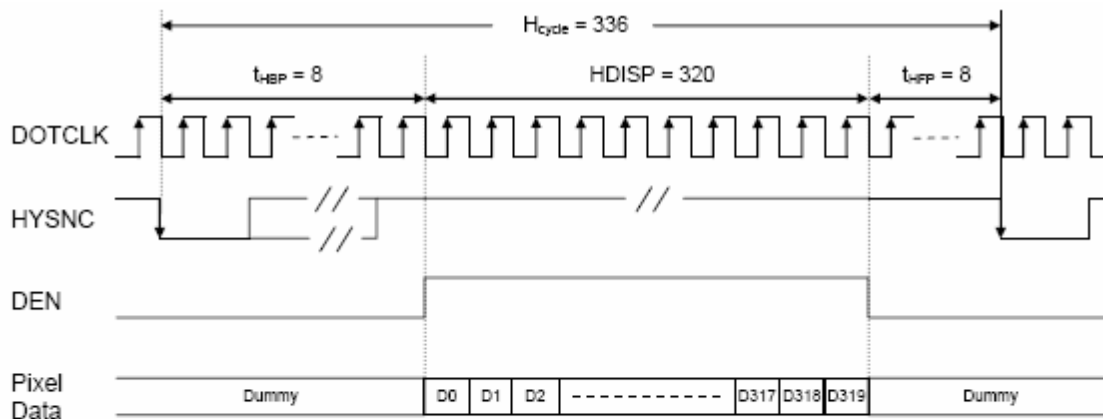

a) Horizontal Data Transaction Timing

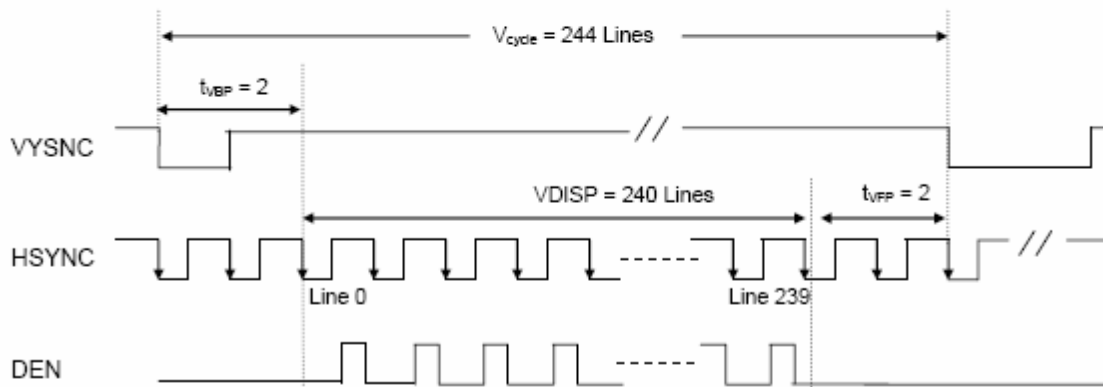

b) Vertical Data Transaction Timing

Characteristics	Symbol	Min	Typ	Max	Unit
DOTCLK Frequency	f_{DOTCLK}	-	5.0	8.0	MHz
DOTCLK Period	t_{DOTCLK}	125	200	-	nSec
Horizontal Frequency (Line)	f_{H}	-	14.9	-	kHz
Vertical Frequency (Refresh)	f_{V}	-	60.1	-	Hz
Horizontal Back Porch	t_{HBP}	-	8	-	t_{DOTCLK}
Horizontal Front Porch	t_{HFP}	-	8	-	t_{DOTCLK}
Horizontal Data Start Point	t_{HBP}	-	8	-	t_{DOTCLK}
Horizontal Blanking Period	$t_{\text{HBP}} + t_{\text{HFP}}$	-	16	-	t_{DOTCLK}
Horizontal Display Area	HDISP	-	320	-	t_{DOTCLK}
Horizontal Cycle	H_{cycle}	-	336	-	t_{DOTCLK}
Vertical Back Porch	t_{VBP}	-	2	-	Line
Vertical Front Porch	t_{VFP}	-	2	-	Line
Vertical Data Start Point	t_{VBP}	-	2	-	Line
Vertical Blanking Period	$t_{\text{VBP}} + t_{\text{VFP}}$	-	4	-	Line
Vertical Display Area	VDISP	-	240	-	Line
Vertical Cycle	V_{cycle}	-	244	-	Line

7-3. Synchronization Signals Timing in Power Save Mode (8 color)

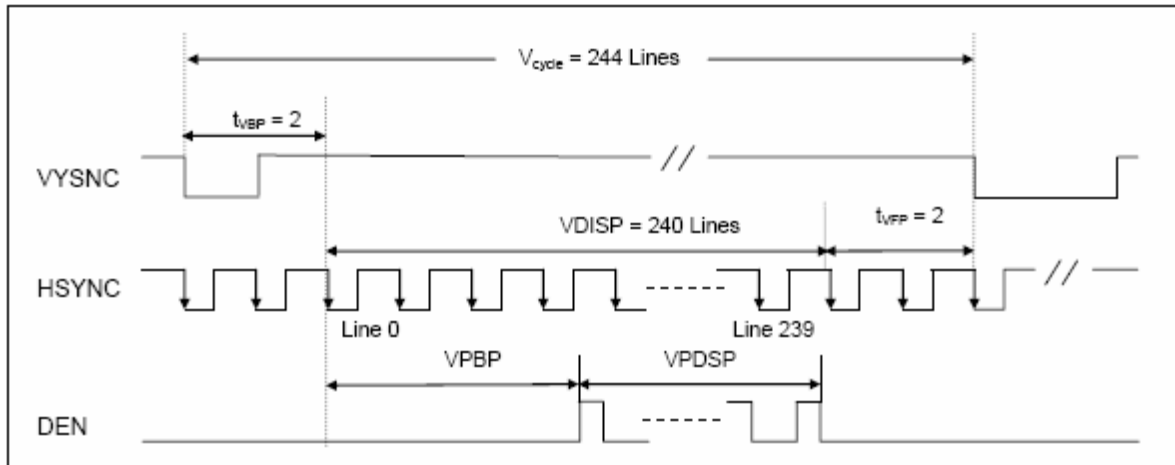

Characteristics	Symbol	Min	Typ	Max	Units
DOTCLK Frequency	f_{DOTCLK}	-	5.0	8.0	MHz
DOTCLK Period	t_{DOTCLK}	125	200	-	nSec
Horizontal Frequency (Line)	f_{H}	-	14.9	-	kHz
Vertical Frequency (Refresh)	f_{V}	-	60.1	-	Hz
Vertical Partial Back Porch	VPBP	0	-	239	Line
Vertical Active Area	VPDSP	1	-	240	Line
Vertical Back Porch	t_{VBP}	-	2	-	Line
Vertical Front Porch	t_{VFP}	-	2	-	Line
Vertical Display Area	VDISP	-	240	-	Line
Vertical Cycle	V_{cycle}	-	244	-	Line

Note: When entered to 8-color display mode, the RGB graphic data through the interface pins RR5, GG5 and BB5 are valid within the Vertical Active Area. Data "0" will be displayed outside the Vertical Active Area.

Synchronization Signals Timing in Power Save Mode (8 color)

7-4. V_{GH} Output against SHUT & RESB

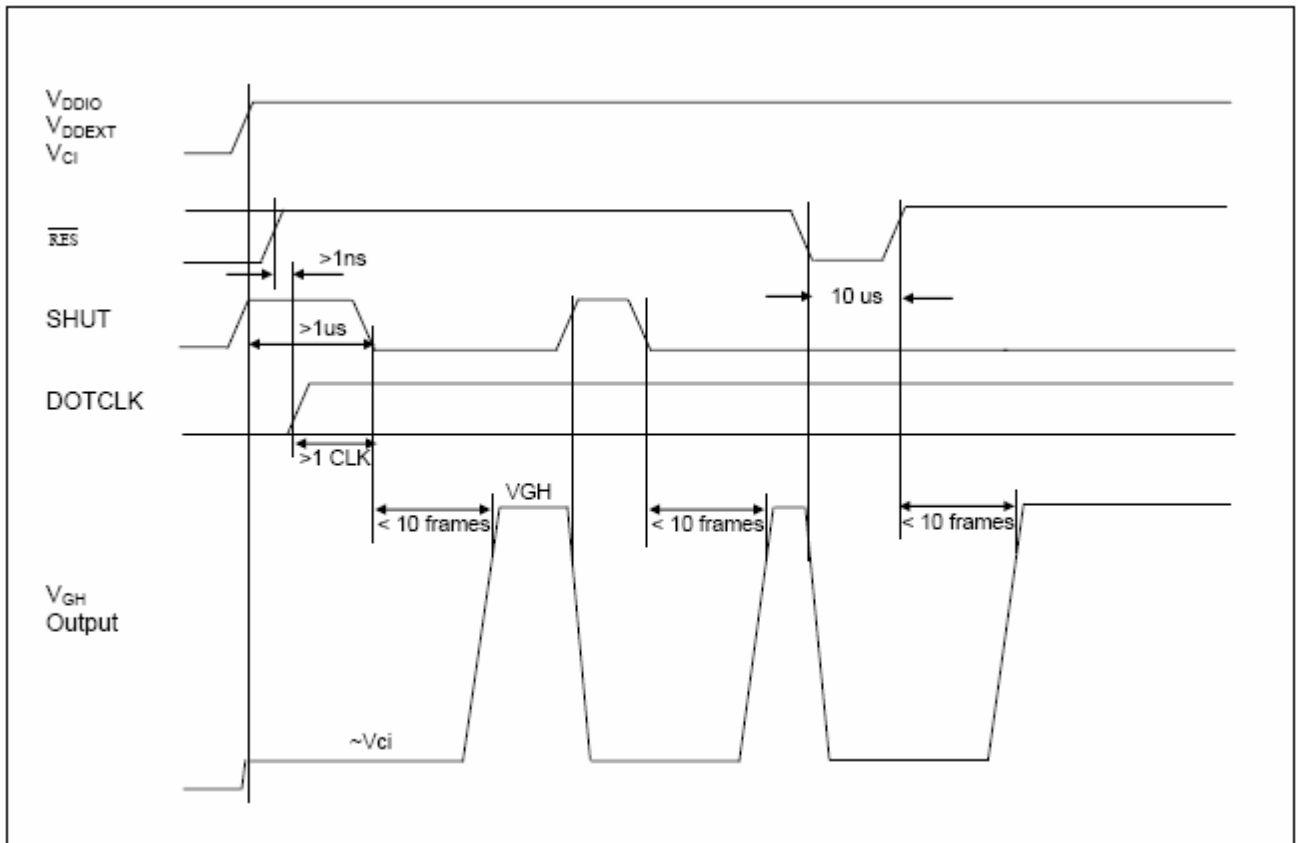

V_{GH} Output against SHUT & RESB

- Note1:** The minimum cycle time of SHUT is $10 + 2$ frames.
- Note2:** DOTCLK must be provided for boosting of V_{GH} . The above timing diagram assumed voltages and DOTCLK are continuous supplied after power on.
- Note3:** V_{GH} will be forced to V_{CI} at the low stage of \overline{RES} .
- Note4:** The minimum pulse width of RESET is $10\ \mu s$.

7-5. Power Up Sequence

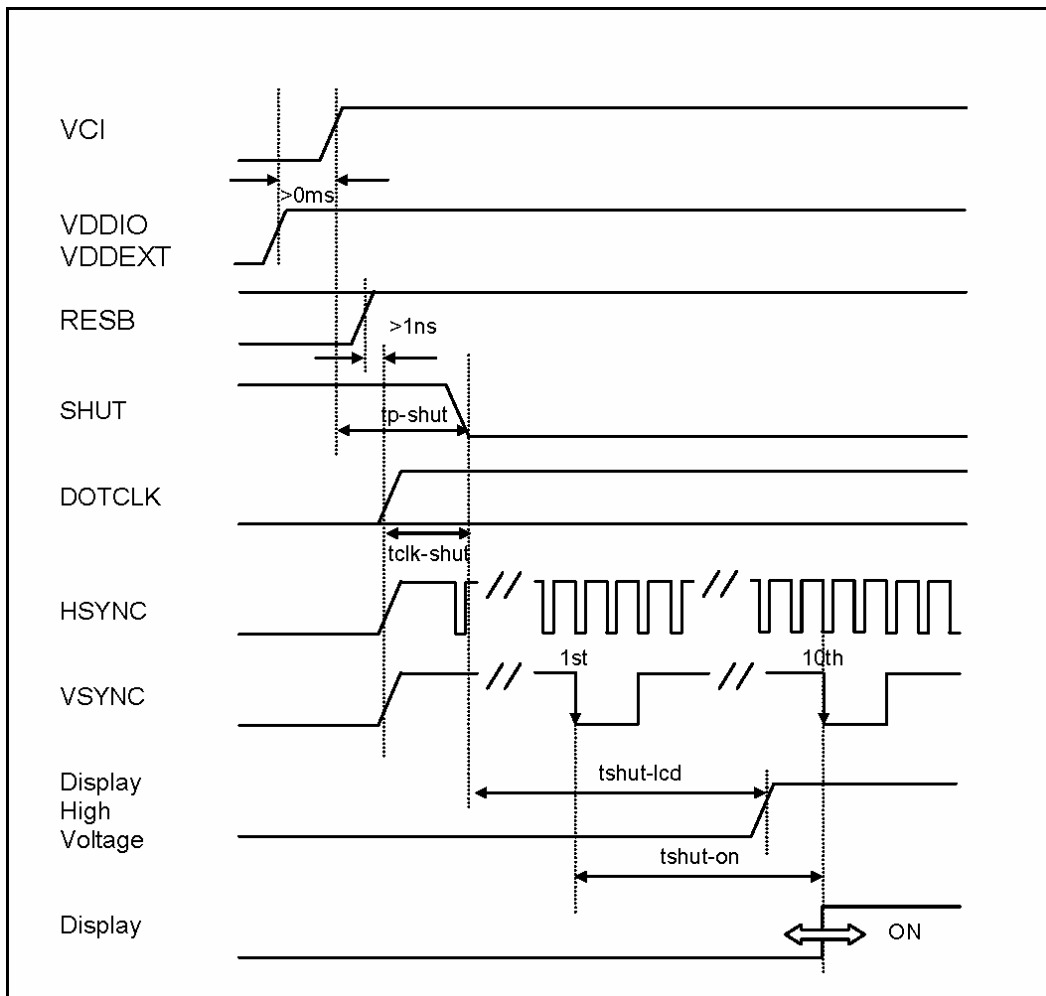

Characteristics	Symbol	Min	Typ	Max	Units
V_{DDEXT} / V_{DDIO} on to falling edge of SHUT	tp-shut	1	-	-	μ sec
DOTCLK	tclk-shut	1	-	-	clk
Falling edge of SHUT to LCD power on	tshut-lcd	-	-	164	msec
Falling edge of SHUT to display start	tshut-on	-	-	10	frame
-- 1 line: 336 clk		-	164	-	msec
-- 1 frame: 244 line		-	164	-	msec
-- DOTCLK = 5.0MHz		-	164	-	msec

Note1: It is necessary to input DOTCLK before the falling edge of SHUT.

Note2: Display starts at 10th falling edge of VSTNC after the falling edge of SHUT.

7-6. Power Down Sequence

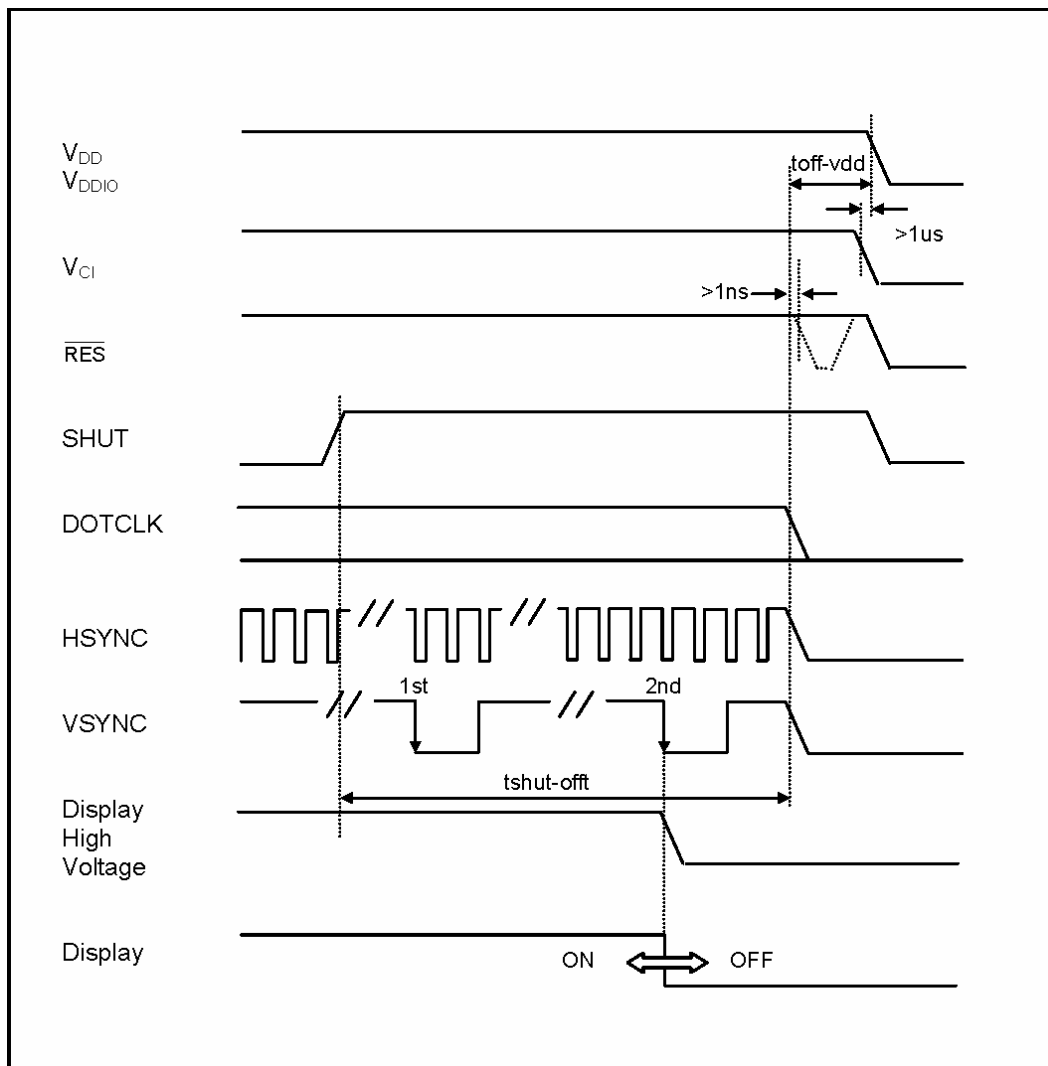

Characteristics	Symbol	Min	Typ	Max	Units
Rising edge of SHUT to display off	tshut-off	2	-	-	frame
-- 1 line: 336 clk		32.8	-	-	msec
-- 1 frame: 244 line					
-- DOTCLK = 5.0 MHz					
Input-signal-off to V _{DDEXT} / V _{DDIO} off	toff-vdd	1	-	-	μsec

Note1: DOTCLK must be maintained at least 2 frames after the rising edge of SHUT.

Note2: Display become off at the 2nd falling edge of VSTNC after the falling edge of SHUT.

Note3: If RESET signal is necessary for power down, provide it after the 2-frames-cycle of the SHUT period.

7-7. SPI Interface Timing Diagram & Transaction Example (9 bit)

The clock synchronized serial peripheral interface (SPI) using the chip select line (CSB), serial transfer clock line (SCK), serial input data (SDI). The serial data transfer starts at the falling edge of CSB input and ends at the rising edge of CSB. DC bit determinate the data of SDI which is register or data.

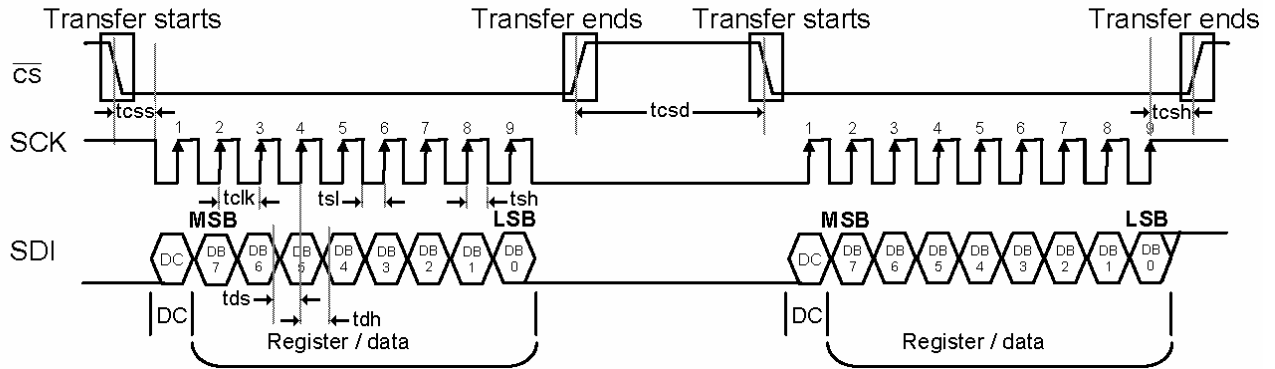

Characteristics	Symbol	Min	Typ	Max	Units
Serial Clock Frequency	fclk	-	-	20	MHz
Serial Clock Cycle Time	tclk	50	-	-	nsec
Clock Low Width	tsl	25	-	-	nsec
Clock High Width	tsh	25	-	-	nsec
Chip Select Setup Time	tcss	0	-	-	nsec
Chip Select Hold Time	tcsh	10	-	-	nsec
Chip Select High Delay Time	tcsd	20	-	-	nsec
Data Setup Time	tds	5	-	-	nsec
Data Hold Time	tdh	10	-	-	nsec

7-8. Input Data Signals and Display Position on the screen

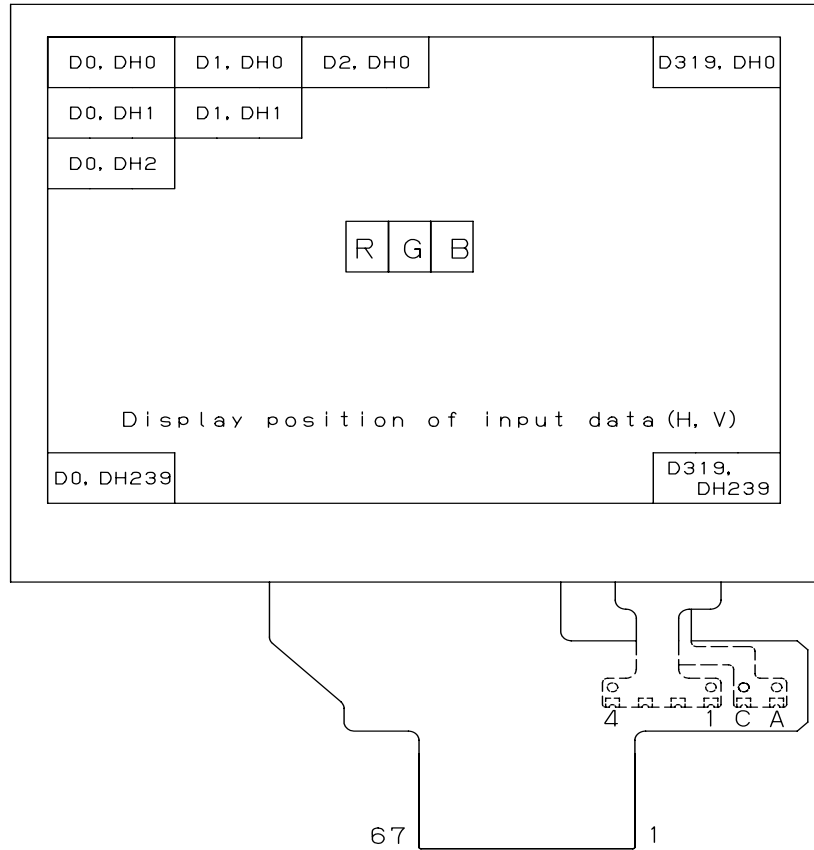

Please refer to Input Terminal Names and Functions

8. Input Signals, Basic Display Colors and Gray Scale of Each Color

	Colors &	Data signal																		
		Gray	R0	R1	R2	R3	R4	R5	G0	G1	G2	G3	G4	G5	B0	B1	B2	B3	B4	B5
		Scale	MSB						MSB						MSB					
Basic Color	Black	—	0	0	0	0	0	0	0	0	0	0	0	0	0	0	0	0	0	0
	Blue	—	0	0	0	0	0	0	0	0	0	0	0	0	1	1	1	1	1	1
	Green	—	0	0	0	0	0	0	1	1	1	1	1	1	0	0	0	0	0	0
	Cyan	—	0	0	0	0	0	0	1	1	1	1	1	1	1	1	1	1	1	1
	Red	—	1	1	1	1	1	1	0	0	0	0	0	0	0	0	0	0	0	0
	Magenta	—	1	1	1	1	1	1	0	0	0	0	0	0	1	1	1	1	1	1
	Yellow	—	1	1	1	1	1	1	1	1	1	1	1	1	0	0	0	0	0	0
	White	—	1	1	1	1	1	1	1	1	1	1	1	1	1	1	1	1	1	1
Gray Scale of Red	Black	GS0	0	0	0	0	0	0	0	0	0	0	0	0	0	0	0	0	0	0
	↑	GS1	1	0	0	0	0	0	0	0	0	0	0	0	0	0	0	0	0	0
	Darker	GS2	0	1	0	0	0	0	0	0	0	0	0	0	0	0	0	0	0	0
	↑	↓	↓						↓						↓					
	↓	↓	↓						↓						↓					
	Brighter	GS61	1	0	1	1	1	1	0	0	0	0	0	0	0	0	0	0	0	0
	↓	GS62	0	1	1	1	1	1	0	0	0	0	0	0	0	0	0	0	0	0
	Red	GS63	1	1	1	1	1	1	0	0	0	0	0	0	0	0	0	0	0	0
Gray Scale of Green	Black	GS0	0	0	0	0	0	0	0	0	0	0	0	0	0	0	0	0	0	0
	↑	GS1	0	0	0	0	0	0	1	0	0	0	0	0	0	0	0	0	0	0
	Darker	GS2	0	0	0	0	0	0	0	1	0	0	0	0	0	0	0	0	0	0
	↑	↓	↓						↓						↓					
	↓	↓	↓						↓						↓					
	Brighter	GS61	0	0	0	0	0	0	1	0	1	1	1	1	0	0	0	0	0	0
	↓	GS62	0	0	0	0	0	0	0	1	1	1	1	1	0	0	0	0	0	0
	Green	GS63	0	0	0	0	0	0	1	1	1	1	1	1	0	0	0	0	0	0
Gray Scale of Blue	Black	GS0	0	0	0	0	0	0	0	0	0	0	0	0	0	0	0	0	0	0
	↑	GS1	0	0	0	0	0	0	0	0	0	0	0	0	1	0	0	0	0	0
	Darker	GS2	0	0	0	0	0	0	0	0	0	0	0	0	0	1	0	0	0	0
	↑	↓	↓						↓						↓					
	↓	↓	↓						↓						↓					
	Brighter	GS61	0	0	0	0	0	0	0	0	0	0	0	0	1	0	1	1	1	1
	↓	GS62	0	0	0	0	0	0	0	0	0	0	0	0	0	1	1	1	1	1
	Blue	GS63	0	0	0	0	0	0	0	0	0	0	0	0	1	1	1	1	1	1

0: Low level voltage, 1: High level voltage

Each basic color can be displayed in 64 gray scales from 6 bit data signals.
 According to the combination of 18 bit data signals, the 262k color display can be achieved on the screen.

9. Optical Characteristics

Ta = 25°C, V_{DDIO} = +3.3V, V_{CI} = +3.3V

Parameter		Symbol	Condition	Min.	Typ.	Max.	Unit	Remark
Viewing angle range (Without Wide View)	Horizontal	θ21	CR > 10	-	45	-	deg.	【Note1,4】
		θ22		-	45	-	deg.	
	Vertical	θ11		-	20	-	deg.	
		θ12		-	55	-	deg.	
Contrast ratio		CR	Optimum viewing angle	100	300	-		【Note2,4】
Response Time	Rise	τ _r	θ=0°	-	30	45	ms	【Note3,4】
	Decay	τ _d		-	30	45	ms	
Chromaticity of White		x		0.26	0.31	0.36		【Note4】
		y		0.29	0.34	0.39		
Luminance of white		X _{L1}		300	400	-	cd/m ²	I _{LED} =20mA 【Note6】
Uniformity		U		70	80		%	【Note5】

* The optical characteristics measurements are operated under a stable luminescence (I_{LED} = 20mA) and a dark condition. (Refer to Fig.9-1)

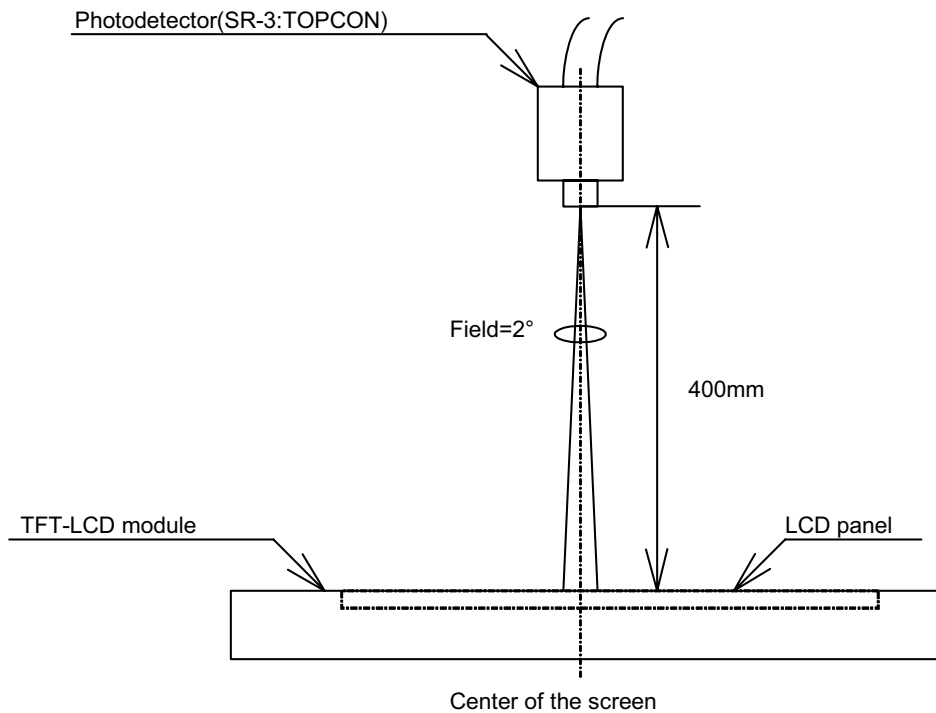
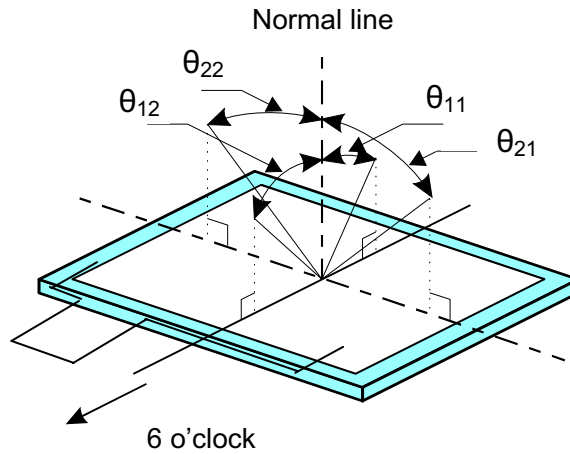

Fig.9-1 Optical characteristics measurement method

【 Note 1 】 Definitions of viewing angle range



【 Note 2 】 Definition of contrast ratio

The contrast ratio is defined as the following

$$\text{Contrast ratio (CR)} = \frac{\text{Luminance (brightness) with all pixels white}}{\text{Luminance (brightness) with all pixels black}}$$

【 Note 3 】 Definition of response time

The response time is defined as the following figure and shall be measured by switching the input signal for “Black” and “White”

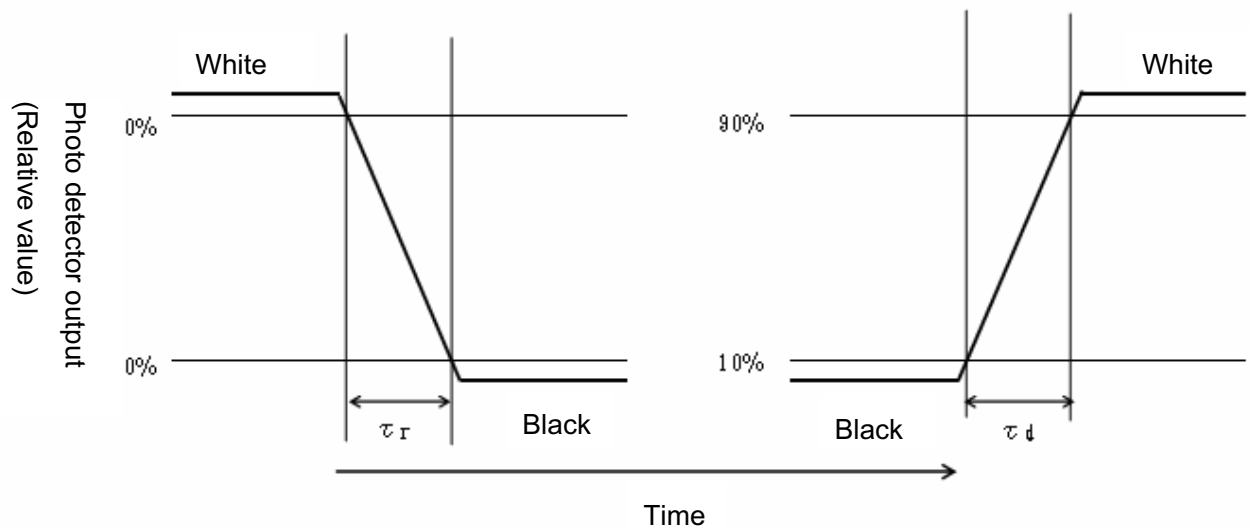

【 Note 4 】 This shall be measured at center of the screen.

【 Note 5 】 Definition of Uniformity

$$\text{Uniformity} = \frac{\text{Minimum Brightness}}{\text{Maximum Brightness}} \times 100 (\%)$$

The brightness should be measured on the 9-point as shown in the right figure.

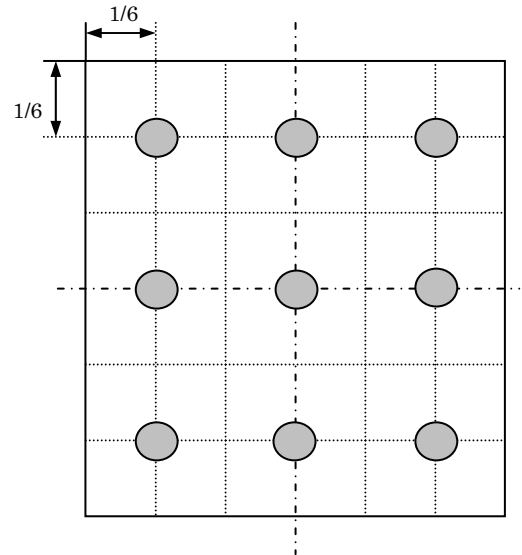

【 Note 6 】 This shall be measured on the 9-point as shown in the right figure.

$$\text{Luminance of white} = \frac{\text{Summation of the 9 - point Brightness}}{9}$$

10. Touch panel characteristics

Parameter	Min.	Typ.	Max.	Unit	Remark
Input voltage	-	5.0	7.0	V	
Resistor between terminals(XL-XR)	260	615	1,200	Ω	Provisional specification
Resistor between terminals(YU-YD)	160	400	800	Ω	
Line linearity(X direction)	-	-	1.5	%	
Line linearity(Y direction)	-	-	1.5	%	
Insuration resistance	20	-	-	MΩ	at DC25V
Minimum tension for detecting	-	-	0.8	N	

Note) For use of finger input

11. Handling of modules

11-1. Inserting the FPC into its connector and pulling it out

- 1) Be sure to turn off the power supply and the signals when inserting or disconnecting the cable.
- 2) Please insert for too much stress not to join FPC in the case of insertion of FPC.

11-2. About handling of FPC

- 1) The bending radius of the FPC should be more than 1.4mm, and it should be bent evenly.
- 2) Do not dangle the LCD module by holding the FPC, or do not give any stress to it.

11-3. Mounting of the module

- 1) The module should be held on to the plain surface. Do not give any warping or twisting stress to the module.
- 2) Please consider that GND can ground a modular metal portion etc. so that static electricity is not charged to a module.
- 3) Design guidance for touch panel (T/P)
 - a) Example of housing design
 - (1) If a consumer will put a palm on housing in normal usage, care should be taken as follows.
 - (2) Keep the gap, for example 0.3 to 0.7mm, between bezel edge and T/P surface.
The reason is to avoid the bezel edge from contacting T/P surface that may cause a "short" with bottom layer. (See Fig.11-3-1)
 - (3) Insertion a cushion material is recommended.
 - (4) The cushion material should be limited just on the busbar insulation paste area.
If it is over the transparent insulation paste area, a "short" may be occurred.
 - (5) There is one where a resistance film is left in the T/P part of the end of the pole.
Design to keep insulation from the perimeter to prevent from mis-operation and so on.

b) Mounting on display and housing bezel

- (1) In all cases, the T/P should be supported from the backside of the Plastic.
- (2) Do not use an adhesive-tape to bond it on the front of T/P and hang it to the housing bezel.
- (3) Never expand the T/P top layer (PET-film) like a balloon by internal air pressure.

The life of the T/P will be extremely short.

- (4) Top layer, PET, dimension is changing with environmental temperature and humidity.

Avoid a stress from housing bezel to top layer, because it may cause “waving”.

- (5) The input to the touch panel sometimes distorts touch panel itself.

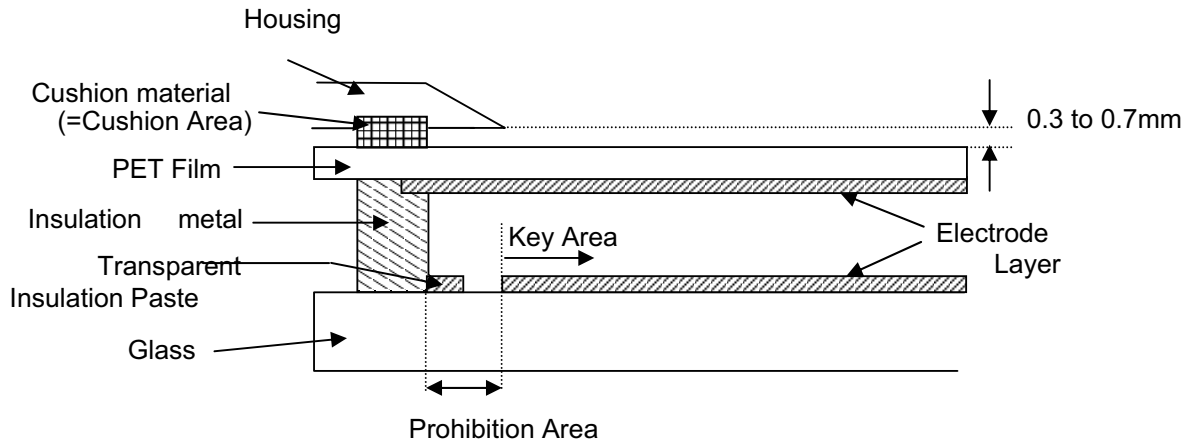

Fig.11-3-1

11-4. Cautions in assembly / Handling pre cautions

As the polarizer can be easily scratched, be most careful in handling it.

1) Work environments in assembly.

Working under the following environments is desirable:

- a) Implement more than 1MΩ conductive treatment (by placing a conductive mat or applying conductive paint) on the floor or tiles.
- b) No dusts come in to the working room. Place an adhesive, anti-dust mat at the entrance of the room.
- c) Humidity of 50 to 70% and temperature of 15 to 27°C are desirable.
- d) All workers wear conductive shoes, conductive clothes, conductive fingerstalls and grounding belts without fail.
- e) Use a blower for electrostatic removal. Set it in a direction slightly tilt downward so that each Module can be well subjected to its wind. Set the blower at an optimum distance between the blower and the module.

2) How the remove dust on the polarizer

- a) Blow out dust by the use of an N2 blower with antistatic measures taken. Use of an ionized air Gun is recommendable.
- b) When the panel surface is soiled, wipe it with soft cloth.

3) In the case of the module's metal part (shield case) is stained, wipe it with a piece of dry, soft cloth.

If rather difficult, give a breath on the metal part to clean better.

- 4) If water dropped, etc. remains stuck on the polarizer for a long time, it is apt to get discolored or cause stains. Wipe it immediately.
- 5) As a glass substrate is used for the TFT-LCD panel, if it is dropped on the floor or hit by something hard, it may be broken or chipped off.
- 6) Since CMOS LSI is used in this module, take care of static electricity and take the human earth into consideration when handling.

11-5. Others

- 1) Regarding storage of LCD modules, avoid storing them at direct sunlight-situation.

You are requested to store under the following conditions:

(Environmental conditions of temperature/humidity for storage)

- a) Temperature: 0 to 40°C
- b) Relative humidity : 95% or less

As average values of environments (temperature and humidity) for storing, use the following control guidelines:

Summer season: 20 to 35°C, 85% or less Winter season: 5 to 15°C, 85% or less

If stored under the conditions of 40°C and 95% RH, cumulative time of storage must be less than 240 hours.

- 2) If stored at temperatures below the rated values, the inner liquid crystal may freeze, causing cell destruction. At temperatures exceeding the rated values for storage, the liquid crystal may become isotropic liquid, making it no longer possible to come back to its original state in some cases.
- 3) If the LCD is broken, do not drink liquid crystal in the mouth. If the liquid crystal adheres to a hand or foot or to clothes, immediately cleanse it with soap.
- 4) If a water drop or dust adheres to the polarizer, it is apt to cause deterioration. Wipe it immediately.
- 5) Be sure to observe other caution items for ordinary electronic parts and components.
- 6) If local pressure joins T/P surface for a long time, it will become the cause of generating of Newton's ring.

12. Reliability test items

No.	Test item	Conditions
1	High temperature storage test	Ta = 85°C 240h
2	Low temperature storage test	Ta = -30°C 240h
3	High temperature & high humidity operation test	Ta = 40°C ; 95%RH 240h (No condensation)
4	High temperature operation test	Ta = 70°C 240h (The panel temp. must be less than 50°C)
5	Low temperature operation test	Ta = -10°C 240h
6	Vibration test (non- operating)	Frequency range: 10 to 55Hz Stroke: 1.5mm Sweep time: 1minutes Test period: 2 hours for each direction of X,Y,Z
7	Shock test	Direction: ±X, ±Y, ±Z, Time: Third for each direction. Impact value: 980m/s ² , Action time 6ms
8	Thermal shock test	Ta=-10°C to 70°C /10 cycles (30 min) (30min)
9	Point activation test (Touch panel)	Hit it 100,000 times with a silicon rubber. Hitting force : 2.4 N Hitting speed : 2 times per second
10	Electro static discharge test	±200V·200pF(0Ω) to Terminals(Contact) (1 time for each terminals) ±4kV · 150pF(330Ω) to Housing bezel or T/P(Contact) ±8kV · 150pF(330Ω) to Housing bezel or T/P(in Air)

【Note】 Ta = Ambient temperature, Tp = Panel temperature

【Check items】

(a)Test No.1 to No.8

In the standard condition, there shall be no practical problems that may affect the display function.

(b)Test No.9

The measurements after the tests are satisfied “10 Touch panel characteristics”.

13. Display Grade

The standard regarding the grade of color LCD displaying modules should be based on the delivery inspection standard.

14. Delivery Form

14-1. Carton storage conditions

1) Carton piling-up: Max 8 rows

2) Environments

Temperature: 0~40°C

Humidity: 65% RH or less (at 40°C)

There should be no dew condensation even at a low temperature and high humidity.

3) Packing form: As shown in 16. LCD module packing carton

※Cartons are weak against damp, and they are apt to be smashed easily due to the compressive pressure applied when piled up. The above environmental conditions of temperature and humidity are set in consideration of reasonable pile-up for storage.

14-2. Packing composition

Name	quantity	Note
Carton size	1	575×360×225 (mm)
Tray	12	Material: Electrification prevention polypropylene
(The number of Module)	120	12 unit/tray: 120 unit/carton
Electrification prevention bag	2	Material: Electrification prevention polyethylene 680mm(length)×500mm(depth)×50μm(thin)

Carton weight (120 modules): Approx. 9.8kg

15. Lot No. marking

The lot No. will be indicated on individual labels. The location is as shown

Indication Label

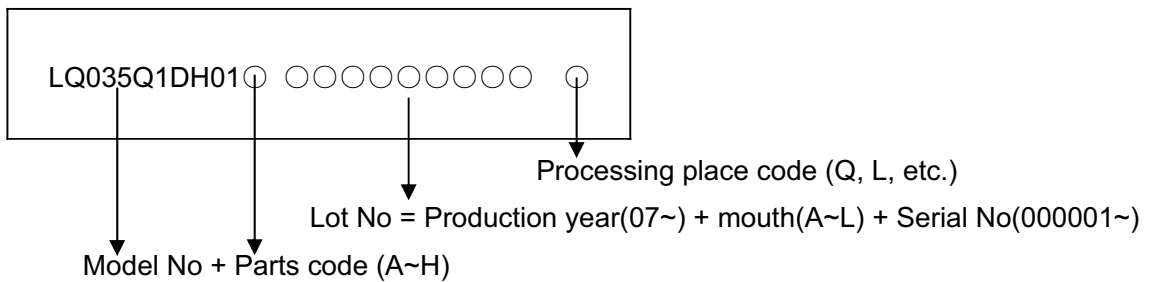

16. LCD module packing carton

TYPE		Internal NO. #431LQ035Q1DH01
QUANTITY		Lot NO. (11) 2007. XX.XX
LOT(ATE)		Quantity (0) 120 PCS
		User NO. 1
		SHARP Distribution Label. (X)

[Quantities]

- 1 tray: 12 modules (MAX)
- 1 sleeve: 60modules (MAX)
- 1 carton: 120modules (MAX)

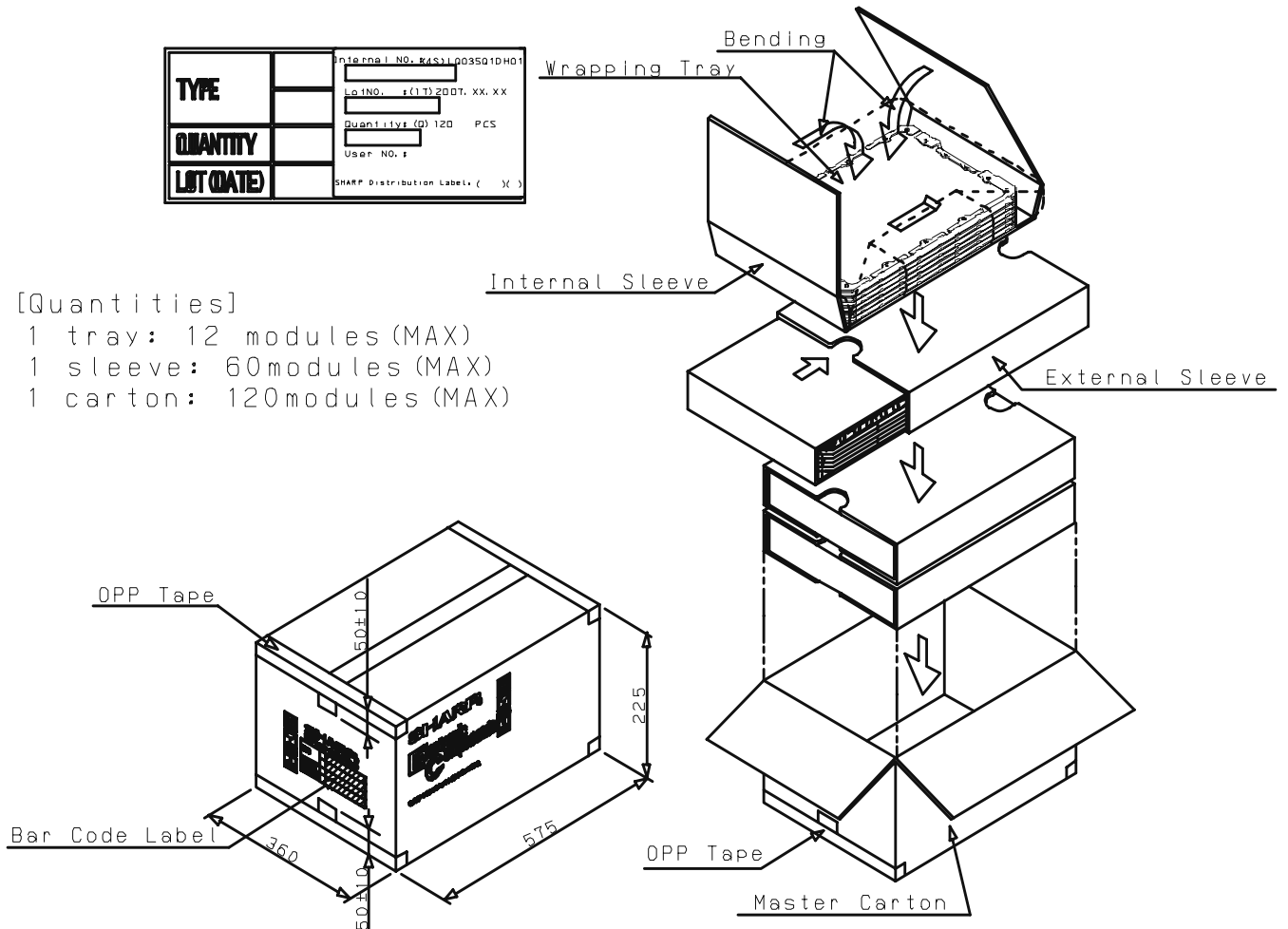

17. Others

- 1 Disassembling the module can cause permanent damage and you should be strictly avoided.
- 2 Please be careful that you don't keep the screen displayed fixed pattern image for a long time, since retention may occur.
- 3 If you pressed down a liquid crystal display screen with your finger and so on, the alignment disorder of liquid crystal will occur. And then It will become display fault.
Therefore, be careful not to touch the screen directly, and to consider not stressing to it.
- 4 If any problem arises regarding the items mentioned in this specification sheet or otherwise, it should be discussed and settled mutually in a good faith for remedy and/or improvement.

18. Sticking position of insulated tape in Soldering area

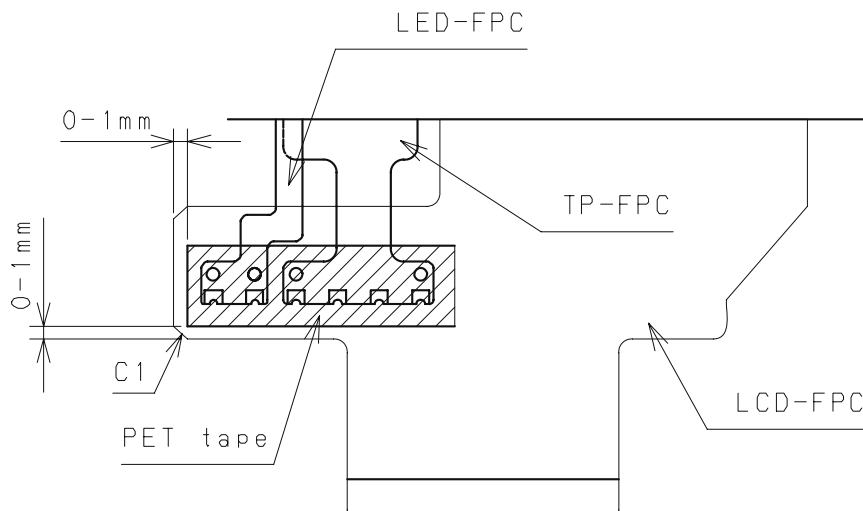

Notice: Do not stick out of the edge of FPC.

19.Outline Dimensions

