

PULSE+



PAGING HORN SPEAKER, ABS, 100V
Model: PHV15 and PHV30

Please read these instructions carefully before use and retain for future reference.

IMPORTANT SAFETY INFORMATION

- When using any electrical appliances basic safety precautions should always be followed.

Safety Information for Installation and Operation

- Check the product before use for any damage. Should you notice any damage on the cable or casing, do not use.
- When installing, make sure that the product is not exposed to extreme heat, moisture or dust.
- Do not expose to flammable sources or gases.
- A secondary means of suspension should be provided, such that in the event of a failure of the primary suspension, no part of the speaker can fall.
- The operator must be sure that safety related matters are observed and that the installation is approved by a qualified installer before use.
- Avoid the loudspeaker cable coming into contact with other cables.
- Handle the loudspeaker cable and all mains voltage connections with particular caution!
- Beware of high voltages in the speaker cable. Always power down the source equipment and disconnect from the mains supply before cleaning or connecting or disconnecting any cables.
- Do not open the equipment and do not attempt to modify the equipment, there are no user serviceable parts inside.
- Do not power the equipment on and off in short intervals, as this will reduce the devices life span.
- Make sure that the loudspeaker cable is not crushed or damaged. Check the equipment and the loudspeaker cable periodically.
- If the equipment is dropped or damaged, disconnect the supply immediately and have a qualified engineer inspect the equipment before operating again.
- Only use fuses of same type and rating.

PRODUCT OVERVIEW

- This 100V horn loudspeaker is designed specifically for use in permanent audio installations, where sound quality and reliability are required. Highly rugged construction and a highly efficient design make this horn speaker perfect for continuous use applications.

FEATURES

- Weather resistant horn loudspeakers suitable for indoor or outdoor applications.
- Ideal for general purpose and standard industrial installations.
- 30W/15W power taps at 100V line - PHV30.
- 15W/7.5W power taps at 100V line - PHV15.
- Supplied with adjustable angle mounting bracket.
- Tough ABS enclosure.

INSTALLATION

- Avoid excessive force when installing.
- Always install on a surface that can support the weight of the speaker.
- Using the mounting bracket as a template mark the wall then drill three holes and fit wall plugs if required.
- Attach the mounting bracket onto the wall with the screws.
- Connect the 100V/70V supply wiring as follows:-
 - Green wire: Full power tapping
 - White wire: Half power tapping
 - Black wire: Common ground terminal.
- Attach the loudspeaker to the mounting bracket using the screws on either side.
- Adjust the directional angle of the speaker before fully tightening the screws.

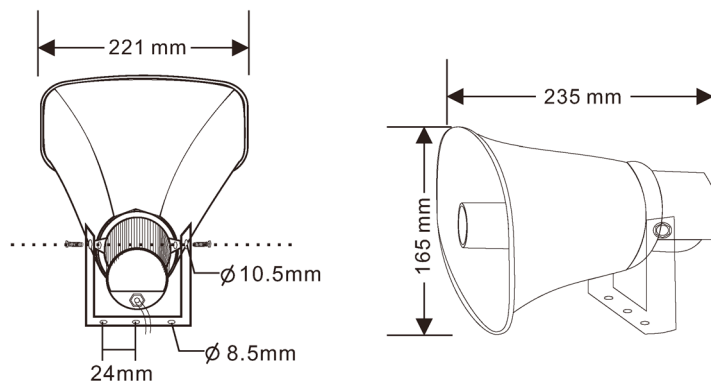
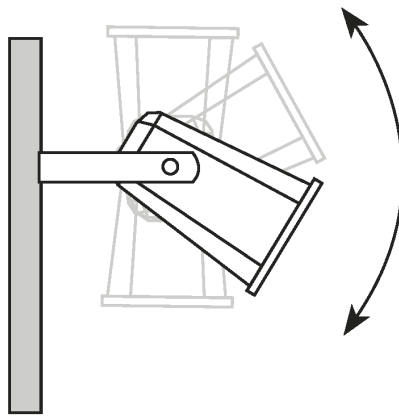

PHV15

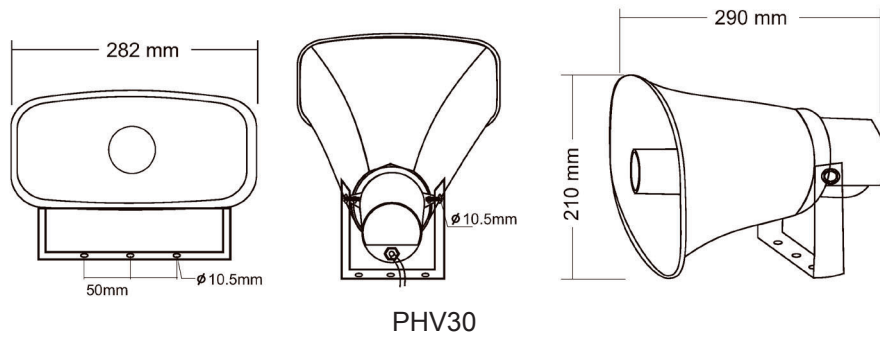

SPECIFICATIONS

MHV50	PHV15	PHV30
Power Taps@100V	Green:15W, White:7.5W	Green:30W, White:15W
Power Taps@70V	Green:7.5W, White:3.75W	Green:15W, White:7.5W
Impedance	Black: COM: 1.3k Ω 670 Ω	Black: COM: 330 Ω 670 Ω
SPL(1W/1M)	103dB \pm 3dB	103dB \pm 3dB
Freq Response	250-8KHz	300-13KHz
IP Ratng	IP65	IP65
Dimensions	221x235x165mm	282x210x290mm
Weight	1.6Kg	2.1Kg



INFORMATION ON WASTE DISPOSAL FOR CONSUMERS OF ELECTRICAL & ELECTRONIC EQUIPMENT.

When this product has reached the end of its life it must be treated as Waste Electrical & Electronic Equipment (WEEE). Any WEEE marked products must not be mixed with general household waste, but kept separate for the treatment, recovery and recycling of the materials used. Contact your local authority for details of recycling schemes in your area.

Made in China.
 PO Box 13362 Dublin 2
 PR2 9PP
 Man Rev 1.0