

GPIB

GPIB-140A User Manual

Worldwide Technical Support and Product Information

ni.com

Worldwide Offices

Visit ni.com/niglobal to access the branch office Web sites, which provide up-to-date contact information, support phone numbers, email addresses, and current events.

National Instruments Corporate Headquarters

11500 North Mopac Expressway Austin, Texas 78759-3504 USA Tel: 512 683 0100

For further support information, refer to the *Technical Support and Professional Services* appendix. To comment on National Instruments documentation, refer to the National Instruments Web site at ni.com/info and enter the Info Code *feedback*.

Important Information

Warranty

The GPIB-140A and GPIB-140A/2 are warranted against defects in materials and workmanship for a period of one year from the date of shipment, as evidenced by receipts or other documentation. National Instruments will, at its option, repair or replace equipment that proves to be defective during the warranty period. This warranty includes parts and labor.

The media on which you receive National Instruments software are warranted not to fail to execute programming instructions, due to defects in materials and workmanship, for a period of 90 days from date of shipment, as evidenced by receipts or other documentation. National Instruments will, at its option, repair or replace software media that do not execute programming instructions if National Instruments receives notice of such defects during the warranty period. National Instruments does not warrant that the operation of the software shall be uninterrupted or error free.

A Return Material Authorization (RMA) number must be obtained from the factory and clearly marked on the outside of the package before any equipment will be accepted for warranty work. National Instruments will pay the shipping costs of returning to the owner parts which are covered by warranty.

National Instruments believes that the information in this document is accurate. The document has been carefully reviewed for technical accuracy. In the event that technical or typographical errors exist, National Instruments reserves the right to make changes to subsequent editions of this document without prior notice to holders of this edition. The reader should consult National Instruments if errors are suspected. In no event shall National Instruments be liable for any damages arising out of or related to this document or the information contained in it.

EXCEPT AS SPECIFIED HEREIN, NATIONAL INSTRUMENTS MAKES NO WARRANTIES, EXPRESS OR IMPLIED, AND SPECIFICALLY DISCLAIMS ANY WARRANTY OF MERCHANTABILITY OR FITNESS FOR A PARTICULAR PURPOSE. CUSTOMER'S RIGHT TO RECOVER DAMAGES CAUSED BY FAULT OR NEGLIGENCE ON THE PART OF NATIONAL INSTRUMENTS SHALL BE LIMITED TO THE AMOUNT THEREOF PAID BY THE CUSTOMER. NATIONAL INSTRUMENTS WILL NOT BE LIABLE FOR DAMAGES RESULTING FROM LOSS OF DATA, PROFITS, USE OF PRODUCTS, OR INCIDENTAL OR CONSEQUENTIAL DAMAGES, EVEN IF ADVISED OF THE POSSIBILITY THEREOF. This limitation of the liability of National Instruments will apply regardless of the form of action, whether in contract or tort, including negligence. Any action against National Instruments must be brought within one year after the cause of action accrues. National Instruments shall not be liable for any delay in performance due to causes beyond its reasonable control. The warranty provided herein does not cover damages, defects, malfunctions, or service failures caused by owner's failure to follow the National Instruments installation, operation, or maintenance instructions; owner's modification of the product; owner's abuse, misuse, or negligent acts; and power failure or surges, fire, flood, accident, actions of third parties, or other events outside reasonable control.

Copyright

Under the copyright laws, this publication may not be reproduced or transmitted in any form, electronic or mechanical, including photocopying, recording, storing in an information retrieval system, or translating, in whole or in part, without the prior written consent of National Instruments Corporation.

National Instruments respects the intellectual property of others, and we ask our users to do the same. NI software is protected by copyright and other intellectual property laws. Where NI software may be used to reproduce software or other materials belonging to others, you may use NI software only to reproduce materials that you may reproduce in accordance with the terms of any applicable license or other legal restriction.

End-User License Agreements and Third-Party Legal Notices

You can find end-user license agreements (EULAs) and third-party legal notices in the following locations:

- Notices are located in the <National Instruments>_Legal Information and <National Instruments> directories.
- EULAs are located in the <National Instruments>\Shared\MDF\Legal\license directory.
- Review <National Instruments>_Legal Information.txt for more information on including legal information in installers built with NI products.

Trademarks

Refer to the *NI Trademarks and Logo Guidelines* at ni.com/trademarks for more information on National Instruments trademarks.

ARM, Keil, and μ Vision are trademarks or registered of ARM Ltd or its subsidiaries.

LEGO, the LEGO logo, WEDO, and MINDSTORMS are trademarks of the LEGO Group. ©2013 The LEGO Group.

TETRIX by Pitsco is a trademark of Pitsco, Inc. ©2013

FIELDBUS FOUNDATION™ and FOUNDATION™ are trademarks of the Fieldbus Foundation.

EtherCAT® is a registered trademark of and licensed by Beckhoff Automation GmbH.

CANopen® is a registered Community Trademark of CAN in Automation e.V.

DeviceNet™ and EtherNet/IP™ are trademarks of ODVA.

Go!, SensorDAQ, and Vernier are registered trademarks of Vernier Software & Technology. Vernier Software & Technology and vernier.com are trademarks or trade dress.

Xilinx is the registered trademark of Xilinx, Inc.

Taptite and Trilobular are registered trademarks of Research Engineering & Manufacturing Inc.

FireWire® is the registered trademark of Apple Inc.

Linux® is the registered trademark of Linus Torvalds in the U.S. and other countries.

Handle Graphics®, MATLAB®, Real-Time Workshop®, Simulink®, Stateflow®, and xPC TargetBox® are registered trademarks, and TargetBox™ and Target Language Compiler™ are trademarks of The MathWorks, Inc.

Tektronix®, Tek, and Tektronix, Enabling Technology are registered trademarks of Tektronix, Inc.

The Bluetooth® word mark is a registered trademark owned by the Bluetooth SIG, Inc.

The ExpressCard™ word mark and logos are owned by PCMCIA and any use of such marks by National Instruments is under license.

The mark LabWindows is used under a license from Microsoft Corporation. Windows is a registered trademark of Microsoft Corporation in the United States and other countries.

Other product and company names mentioned herein are trademarks or trade names of their respective companies.

Members of the National Instruments Alliance Partner Program are business entities independent from National Instruments and have no agency, partnership, or joint-venture relationship with National Instruments.

Patents

For patents covering National Instruments products/technology, refer to the appropriate location: **Help»Patents** in your software, the `patents.txt` file on your media, or the *National Instruments Patent Notice* at ni.com/patents.

Export Compliance Information

Refer to the *Export Compliance Information* at ni.com/legal/export-compliance for the National Instruments global trade compliance policy and how to obtain relevant HTS codes, ECCNs, and other import/export data.

WARNING REGARDING USE OF NATIONAL INSTRUMENTS PRODUCTS

(1) NATIONAL INSTRUMENTS PRODUCTS ARE NOT DESIGNED WITH COMPONENTS AND TESTING FOR A LEVEL OF RELIABILITY SUITABLE FOR USE IN OR IN CONNECTION WITH SURGICAL IMPLANTS OR AS CRITICAL COMPONENTS IN ANY LIFE SUPPORT SYSTEMS WHOSE FAILURE TO PERFORM CAN REASONABLY BE EXPECTED TO CAUSE SIGNIFICANT INJURY TO A HUMAN.

(2) IN ANY APPLICATION, INCLUDING THE ABOVE, RELIABILITY OF OPERATION OF THE SOFTWARE PRODUCTS CAN BE IMPAIRED BY ADVERSE FACTORS, INCLUDING BUT NOT LIMITED TO FLUCTUATIONS IN ELECTRICAL POWER SUPPLY, COMPUTER HARDWARE MALFUNCTIONS, COMPUTER OPERATING SYSTEM SOFTWARE FITNESS, FITNESS OF COMPILERS AND DEVELOPMENT SOFTWARE USED TO DEVELOP AN APPLICATION, INSTALLATION ERRORS, SOFTWARE AND HARDWARE COMPATIBILITY PROBLEMS, MALFUNCTIONS OR FAILURES OF ELECTRONIC MONITORING OR CONTROL DEVICES, TRANSIENT FAILURES OF ELECTRONIC SYSTEMS (HARDWARE AND/OR SOFTWARE), UNANTICIPATED USES OR MISUSES, OR ERRORS ON THE PART OF THE USER OR APPLICATIONS DESIGNER (ADVERSE FACTORS SUCH AS THESE ARE HEREAFTER COLLECTIVELY TERMED "SYSTEM FAILURES"). ANY APPLICATION WHERE A SYSTEM FAILURE WOULD CREATE A RISK OF HARM TO PROPERTY OR PERSONS (INCLUDING THE RISK OF BODILY INJURY AND DEATH) SHOULD NOT BE RELIANT SOLELY UPON ONE FORM OF ELECTRONIC SYSTEM DUE TO THE RISK OF SYSTEM FAILURE. TO AVOID DAMAGE, INJURY, OR DEATH, THE USER OR APPLICATION DESIGNER MUST TAKE REASONABLY PRUDENT STEPS TO PROTECT AGAINST SYSTEM FAILURES, INCLUDING BUT NOT LIMITED TO BACK-UP OR SHUT DOWN MECHANISMS. BECAUSE EACH END-USER SYSTEM IS CUSTOMIZED AND DIFFERS FROM NATIONAL INSTRUMENTS' TESTING PLATFORMS AND BECAUSE A USER OR APPLICATION DESIGNER MAY USE NATIONAL INSTRUMENTS PRODUCTS IN COMBINATION WITH OTHER PRODUCTS IN A MANNER NOT EVALUATED OR CONTEMPLATED BY NATIONAL INSTRUMENTS, THE USER OR APPLICATION DESIGNER IS ULTIMATELY RESPONSIBLE FOR VERIFYING AND VALIDATING THE SUITABILITY OF NATIONAL INSTRUMENTS PRODUCTS WHENEVER NATIONAL INSTRUMENTS PRODUCTS ARE INCORPORATED IN A SYSTEM OR APPLICATION, INCLUDING, WITHOUT LIMITATION, THE APPROPRIATE DESIGN, PROCESS AND SAFETY LEVEL OF SUCH SYSTEM OR APPLICATION.

Compliance

Electromagnetic Compatibility Information

This hardware has been tested and found to comply with the applicable regulatory requirements and limits for electromagnetic compatibility (EMC) as indicated in the hardware's Declaration of Conformity (DoC)¹. These requirements and limits are designed to provide reasonable protection against harmful interference when the hardware is operated in the intended electromagnetic environment. In special cases, for example when either highly sensitive or noisy hardware is being used in close proximity, additional mitigation measures may have to be employed to minimize the potential for electromagnetic interference.

While this hardware is compliant with the applicable regulatory EMC requirements, there is no guarantee that interference will not occur in a particular installation. To minimize the potential for the hardware to cause interference to radio and television reception or to experience unacceptable performance degradation, install and use this hardware in strict accordance with the instructions in the hardware documentation and the DoC¹.

If this hardware does cause interference with licensed radio communications services or other nearby electronics, which can be determined by turning the hardware off and on, you are encouraged to try to correct the interference by one or more of the following measures:

- Reorient the antenna of the receiver (the device suffering interference).
- Relocate the transmitter (the device generating interference) with respect to the receiver.
- Plug the transmitter into a different outlet so that the transmitter and the receiver are on different branch circuits.

Some hardware may require the use of a metal, shielded enclosure (windowless version) to meet the EMC requirements for special EMC environments such as, for marine use or in heavy industrial areas. Refer to the hardware's user documentation and the DoC¹ for product installation requirements.

When the hardware is connected to a test object or to test leads, the system may become more sensitive to disturbances or may cause interference in the local electromagnetic environment.

Operation of this hardware in a residential area is likely to cause harmful interference. Users are required to correct the interference at their own expense or cease operation of the hardware.

Changes or modifications not expressly approved by National Instruments could void the user's right to operate the hardware under the local regulatory rules.

¹ The Declaration of Conformity (DoC) contains important EMC compliance information and instructions for the user or installer. To obtain the DoC for this product, visit ni.com/certification, search by model number or product line, and click the appropriate link in the Certification column.

Contents

About This Manual

Conventions	ix
Related Documentation	ix

Chapter 1

Introduction

What Your Kit Should Contain	1-1
Optional Equipment	1-1
Hardware Overview	1-2
Time-Saving Development Tools	1-3

Chapter 2

Connecting Your Hardware

Step 1. Verify the DIP Switch Setting	2-1
Step 2. Connect the Cables	2-2
Step 3. Switch On Your GPIB Extender	2-2
Step 4. Verify the Connection	2-2

Chapter 3

Configuring and Using Your Hardware

Data Transfer Modes	3-1
Selecting a Data Transfer Mode	3-1
Unbuffered Mode	3-1
Buffered Mode	3-1
Setting the Data Transfer Mode	3-2
HS488 Mode	3-2
Selecting an HS488 Mode	3-2
HS488 Disabled	3-2
HS488 Enabled	3-2
Setting the HS488 Mode	3-2
Parallel Poll Response Modes	3-3
Immediate PPR Mode	3-3
Latched PPR Mode	3-3
Selecting a PPR Mode	3-4
Setting the PPR Mode	3-4
Using Your Extension System	3-5

Chapter 4

Theory of Operation

Message Interpreter Layer	4-2
Packet Translation Layer	4-2
Link Management Layer.....	4-2
Parallel-to-Serial Conversion Layer	4-2
Physical Layer.....	4-2

Appendix A

GPIB Basics

Appendix B

Introduction to HS488

Appendix C

Multiline Interface Messages

Appendix D

Specifications

Appendix E

Technical Support and Professional Services

Glossary

About This Manual

This manual describes how to install, configure, and operate the National Instruments GPIB-140A or GPIB-140A/2 bus extender.

Conventions

The following conventions appear in this manual:



This icon denotes a note, which alerts you to important information.



This icon denotes a caution, which advises you of precautions to take to avoid injury, data loss, or a system crash.

bold

Bold text denotes the names of LEDs.

GPIB-140A

GPIB-140A refers to a National Instruments GPIB extender that extends the GPIB to a maximum distance of 1 km.

GPIB-140A/2

GPIB-140A/2 refers to a National Instruments GPIB extender that extends the GPIB to a maximum distance of 2 km.

GPIB extender

GPIB extender refers to the GPIB-140A and the GPIB-140A/2.

IEEE 488 and

IEEE 488 and *IEEE 488.2* refer to the ANSI/IEEE Standard 488.1-1987

IEEE 488.2

and the ANSI/IEEE Standard 488.2-1992, respectively, which define the GPIB.

italic

Italic text denotes variables, emphasis, a cross-reference, or an introduction to a key concept. Italic text also denotes text that is a placeholder for a word or value that you must supply.

monospace

Text in this font denotes text or characters that you should enter from the keyboard, sections of code, programming examples, and syntax examples. This font is also used for the proper names of disk drives, paths, directories, programs, subprograms, subroutines, device names, functions, operations, variables, filenames and extensions, and code excerpts.

Related Documentation

The following documents contain information that you might find helpful as you read this manual:

- ANSI/IEEE Standard 488.1-1987, *IEEE Standard Digital Interface for Programmable Instrumentation*
- ANSI/IEEE Standard 488.2-1992, *IEEE Standard Codes, Formats, Protocols, and Common Commands*

Introduction

This chapter lists the kit contents and briefly describes the GPIB-140A bus extender.

What Your Kit Should Contain

Before you connect your GPIB-140A or GPIB-140A/2, make sure you have all of the following items:

- One of the following GPIB-140A or GPIB-140A/2 bus extenders:
 - U.S. 100-120 VAC
 - Switzerland 220-240 VAC
 - Australia 220-240 VAC
 - Universal European 220-240 VAC
 - North American 220-240 VAC
 - U.K. 220-240 VAC
 - Japan 100 VAC

- One of the following standard 3-wire power cables:
 - 100-120 VAC
 - 220-240 VAC

Optional Equipment

- One of the following transmission cables, which you can purchase from National Instruments:
 - Type T7 fiber-optic cable—up to 1 km (used with GPIB-140A)
 - Type T8 fiber-optic cable—up to 2 km (used with GPIB-140A/2)



Caution To meet FCC emission limits for this device, you must use a shielded GPIB cable. If you operate this equipment with a non-shielded cable, it may interfere with radio and television reception.

- A Type X2 double-shielded cable (1, 2, or 4 m), which you can purchase from National Instruments.

Hardware Overview



Note You cannot use the GPIB-140A or GPIB-140A/2 bus extenders to communicate with either a GPIB-140 or GPIB-140/2 bus extender. The GPIB-140A and GPIB-140A/2 bus extenders use a different protocol to communicate with each other across the fiber optic cable.

The GPIB-140A and GPIB-140A/2 are high-speed bus extenders that you can use in pairs with fiber-optic cable to connect two separate GPIB systems in a functionally transparent manner.

Although the two bus systems are physically separate, as shown in Figure 1-1, devices logically appear to be located on the same bus, as shown in Figure 1-2.

Figure 1-1. Typical Extension System (Physical Configuration)

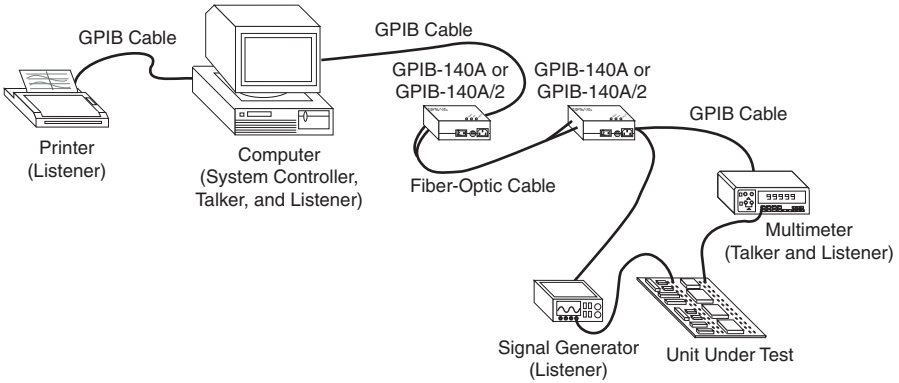
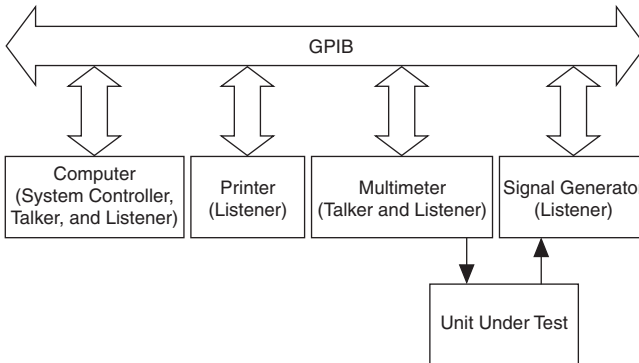

Figure 1-2. Typical Extension System (Logical Configuration)



The GPIB-140A and GPIB-140A/2 bus extenders comply with the specifications of the ANSI/IEEE Standard 488.1-1987 and the ANSI/IEEE Standard 488.2-1992, including the Find Listeners protocol. With the GPIB extenders, you can overcome the following two configuration restrictions imposed by IEEE 488:

- A cable length limit of 20 m total per contiguous bus or 2 m per each device on the bus, whichever is smaller
- An electrical loading limit of 15 devices per contiguous bus

Each GPIB-140A system extends the GPIB to a maximum distance of 1 km, and each GPIB-140A/2 system extends the GPIB to a maximum distance of 2 km. Both systems extend the loading limit to 28 devices (including the GPIB extenders), without sacrificing speed or performance. You can connect these point-to-point extension systems in series for longer distances or in star patterns for additional loading.

Using the HS488 protocol, the maximum data transfer rate over the extension is greater than 2.8 Mbytes/s. The GPIB extenders use a buffered transfer technique with a serial extension bus, which maximizes performance and minimizes the cabling cost. Furthermore, the extender does not affect the transfer rate between devices on the same side of the extension. The GPIB extender can also check for errors to make sure that the data transmitted successfully over the fiber-optic link.

Because the GPIB-140A and GPIB-140A/2 are functionally transparent extenders, the GPIB communications and control programs that work with an unextended system also work with an extended system. However, the [Parallel Poll Response Modes](#) section in Chapter 3, [Configuring and Using Your Hardware](#), describes one exception to this transparency in conducting parallel polls.

Time-Saving Development Tools

Your kit includes the GPIB-140A or GPIB-140A/2 bus extender. In addition, you can order the NI-488.2, LabWindows™/CVI™, or LabVIEW software from National Instruments to speed your application development time and make it easier to communicate with your instruments.

The NI-488.2 software supports the concurrent use of multiple types of GPIB hardware. For example, you can communicate with GPIB devices through a PCI-GPIB, a PCMCIA-GPIB, and a GPIB-ENET/100 in the same system at the same time. The NI-488.2 software, along with the GPIB hardware, transforms your computer into a GPIB Talker/Listener/Controller with complete communications and bus management capability.

LabVIEW is an easy-to-use, graphical programming environment you can use to acquire data from thousands of different instruments, including IEEE 488.2 devices, VXI devices, serial devices, PLCs, and plug-in data acquisition boards. After you have acquired raw data, you can convert it into meaningful results using the powerful data analysis routines in LabVIEW. LabVIEW also comes with hundreds of instrument drivers, which dramatically reduce software development time, because you do not have to spend time programming the low-level control of each instrument.

LabWindows/CVI is similar to LabVIEW, except that it combines an interactive, easy-to-use development approach with the programming power and flexibility of compiled ANSI C code.

The GPIB Analyzer is another optional tool available from National Instruments that is useful in troubleshooting a variety of IEEE 488 hardware and software problems. With its built-in time-stamping capability, you can easily determine the throughput and overhead of your GPIB systems. The GPIB Analyzer software for Windows works with the AT-GPIB/TNT+, PCI-GPIB+, and NI PCIe-GPIB+ products, which provide GPIB Analyzer support along with the functionality of a high-performance GPIB Controller.

For ordering information, or to request free demonstration software, contact National Instruments.

Connecting Your Hardware

This chapter describes how to connect your GPIB extender and verify that it is working properly.

Step 1. Verify the DIP Switch Setting

The 3-bit DIP switch sets the operation mode of the GPIB extender. The default switch setting is for unbuffered transfer mode, latched parallel poll response (PPR), and HS488 disabled mode, as shown in Figure 2-1.

Figure 2-1. Default DIP Switch Setting

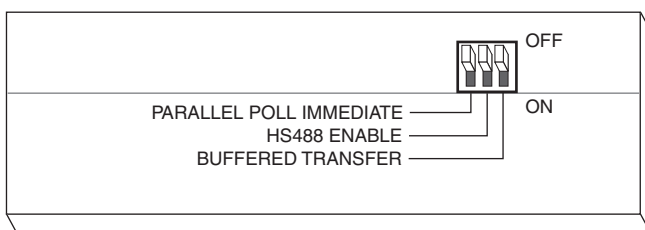

Verify that the DIP switches on your GPIB extender are in these default positions. If you need to change these settings, refer to Chapter 3, *Configuring and Using Your Hardware*, for instructions on how to set the operation mode for your application.

Step 2. Connect the Cables

To connect the cables to both GPIB extenders, complete the following steps:

1. Make sure that each GPIB extender is powered off.
2. Connect the two connectors on each end of the fiber-optic cable to your GPIB extenders, as follows:
 - a. As shown in Figure 2-2, align the connector marked T (transmit) with the connector marked TRANS on the side panel of the GPIB extender. Align the connector marked R (receive) with the connector marked RCVR on the side panel of the GPIB extender.

Figure 2-2. Connecting the Fiber-Optic Cable to Both GPIB Extenders

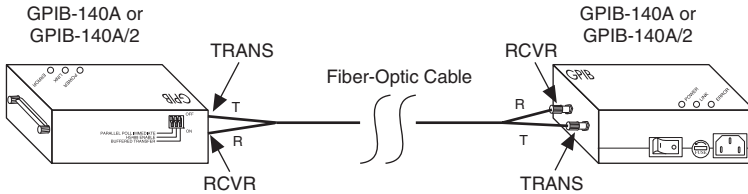

- b. Remove the caps on the connectors.
 - c. Align the notch on each cable connector to the slot of the fiber-optic connector on the box.
 - d. Firmly push in the cable connector and rotate the sleeve clockwise until it locks on to the side notch of the fiber-optic connector on the box.
3. Connect the end of the extender with the GPIB connector to your GPIB system. Make sure that you follow all IEEE 488 cabling restrictions. For typical restrictions, refer to the [Configuration Requirements](#) section in Appendix A, *GPIB Basics*.
4. Plug the utility power cord included with your GPIB extender into an AC outlet of the correct voltage.
5. Plug the other end of the utility power cord into your GPIB extender.

Step 3. Switch On Your GPIB Extender

Power on each GPIB extender. The **POWER** LED should light immediately. If the **POWER** LED does not light immediately, make sure that power is supplied to your GPIB extender.

The **LINK** LED lights only when both GPIB extenders are on and the fiber-optic cable is properly connected between them.

Step 4. Verify the Connection

Each GPIB extender has a self test that determines whether the GPIB extender receivers, transmitters, and packet transmission and reception circuitry are working properly.

To run the self test, complete the following steps:

1. Power off the GPIB extender.
2. Disconnect the fiber-optic cable from the GPIB extender.
3. Power on the GPIB extender.

The **POWER** LED lights, indicating that power is supplied to the extender. The **LINK** LED remains off.

4. Connect the connector marked T (transmit) on one end of the fiber-optic cable to the connector marked TRANS on the side panel of the GPIB extender.
5. Connect the connector marked R (receive) on the opposite end of the fiber-optic cable to the connector marked RCVR on the side panel of the GPIB extender.

Figure 2-3. GPIB Extender Self-Test Configuration

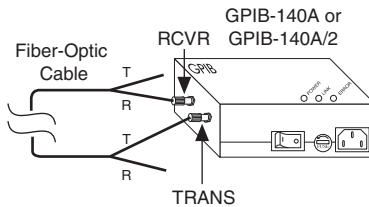

The **LINK** LED lights, indicating that the cable is connected. The **ERROR** LED should remain off, indicating that the GPIB extender is working properly.

6. If the **ERROR** LED does not remain off, complete the following steps to solve the problem:
 - a. Verify that the fiber-optic cable is connected to the GPIB extender, as described in steps 4 and 5. If the problem persists, continue to the next step.
 - b. Repeat steps 4 and 5 using the unconnected ends of the fiber-optic cable. If switching the fiber-optic cable connectors solves the problem, you need to replace your fiber-optic cable. To order a new fiber-optic cable, contact National Instruments. If switching the fiber-optic cable connectors does not solve the problem, continue to the next step.
 - c. If possible, repeat steps 4 and 5 using a different fiber-optic cable. If the problem persists, you might need to replace your GPIB extender. For more information, contact National Instruments.

Configuring and Using Your Hardware

This chapter describes how to configure and use your GPIB-140A or GPIB-140A/2 system.

Data Transfer Modes

The GPIB extender has two data transfer modes—unbuffered mode and buffered mode. The data transfer mode determines how data is transmitted across the extension.

Selecting a Data Transfer Mode

To select a data transfer mode, refer to the following descriptions of each mode.

Unbuffered Mode

In unbuffered mode, each data byte is transmitted using the GPIB double-interlocked handshaking protocol. For long data streams, transfers are slower than transfers using buffered mode. However, the GPIB extension is transparent in unbuffered mode.

Buffered Mode

In buffered mode, the GPIB extenders use FIFO (first-in-first-out) buffers to buffer data between the remote and local units. For long data streams, the data throughput is much higher than with unbuffered mode.

However, a few applications may not operate properly in buffered mode. For example, a GPIB device on the local side of the extension is addressed to talk, another device on the remote side is addressed to listen. When the Talker sources data bytes, the GPIB extenders accept the data bytes and store them in a FIFO buffer. At the same time, the GPIB extenders read data from the FIFO buffer and source data bytes to the Listener. If the FIFO buffer contains data, the number of bytes sourced by the Talker differs from the number of bytes accepted by the Listener.

GPIB command bytes are not stored in the FIFO buffers; they are transmitted using the GPIB double-interlocked handshaking protocol.

Setting the Data Transfer Mode

The two GPIB extenders in your extension system must use the same data transfer mode.

To use buffered mode, set DIP switch 1 to the ON position, as shown in Figure 3-1. To use unbuffered mode, set DIP switch 1 to the OFF position.

Figure 3-1. DIP Switch Setting for Buffered Mode

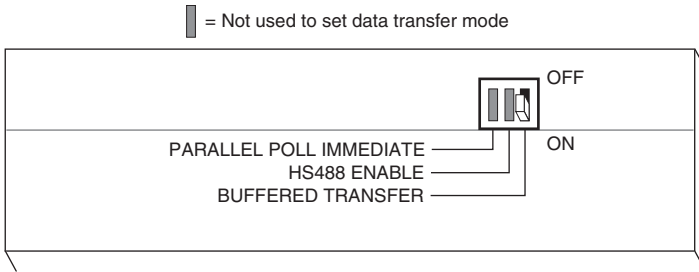

HS488 Mode

The GPIB extender can handle data transfers using the HS488 protocol. HS488 transfers data between two or more devices using a noninterlocked handshaking protocol. You can use HS488 to transfer data at rates higher than rates possible using the IEEE 488 protocol. For more information about HS488, refer to Appendix B, [Introduction to HS488](#).

Selecting an HS488 Mode

To select an HS488 mode, refer to the following descriptions of each mode.

HS488 Disabled

If you disable HS488, the GPIB extender sources and accepts data using a three-wire handshaking protocol, even if both the Talker and Listener can transfer data using the HS488 protocol.

HS488 Enabled

After the Talker indicates that it wants to issue HS488 transfers, HS488 is enabled and the GPIB extender accepts data using the HS488 protocol. Also, when talking, the GPIB extender always tries to use the HS488 mode. In HS488 mode, FIFO buffers buffer data during HS488 transfers, even if the data transfer mode is set to unbuffered. When you use the HS488 protocol with the GPIB extender, you should set the GPIB cable length to 5 m for both the local and the remote system. To do so, use your IEEE 488.2 software configuration utility.

Setting the HS488 Mode

The two GPIB extenders in your extension system do not need to use the same HS488 mode. However, the system uses the maximum data transfer rate when both sides in your extension system use HS488.

To enable HS488, set DIP switch 2 to the ON position, as shown in Figure 3-2. To disable HS488, set DIP switch 2 to the OFF position.

Figure 3-2. DIP Switch Setting for Enabled HS488

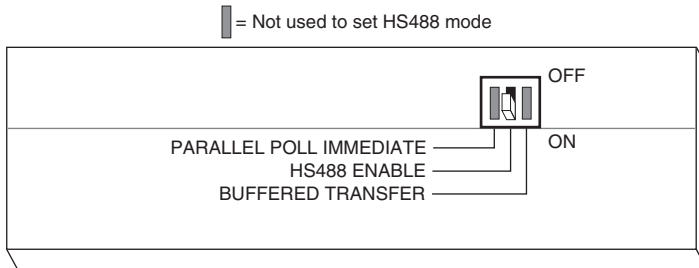

Parallel Poll Response Modes

According to IEEE 488, devices must respond to a parallel poll within 200 ns after the Controller-In-Charge (CIC) asserts the Identify (IDY) message—Attention (ATN) and End or Identify (EOI). The CIC waits at least 2 μ s before reading the Parallel Poll Response (PPR). In many cases, a remote device on an extended system cannot respond to parallel polls this quickly because of cable propagation delays. To solve this problem, use one of the following two solutions in your application:

- If possible, specify in your application that the CIC must allow enough time to receive the response. For more information, refer to the following section, *Immediate PPR Mode*. If you are using the NI-488.2 software, you can use the NI-488.2 Configuration utility to set the amount of time that the CIC waits.
- Execute two consecutive parallel polls and use the second response. For more information, refer to the *Latched PPR Mode* section later in this chapter.

Immediate PPR Mode

In immediate PPR mode, the GPIB extenders do not use the internal PPR data register. When a Controller on the local system asserts IDY, the local extender sends the IDY message to the remote bus and the response is returned as fast as propagation delays permit. Your application must allow enough time to receive the response.

Latched PPR Mode

In latched PPR mode, the GPIB extenders use an internal PPR data register. When a Controller on the local system asserts IDY, the local extender sends the contents of the PPR data register to the local data lines. At the same time, a parallel poll message is sent to the remote bus. When the local system unasserts IDY, the PPR from the remote system is loaded into the internal PPR data register. Consequently, the register always contains the response of the previous complete poll. To obtain the response of both local and remote systems, your application should execute two consecutive parallel polls and use the second response.

The software driver library of most Controllers contains an easy-to-use parallel poll function. For example, if the function is called `ibrpp` and your application is written in BASIC, the sequence to execute a poll in latched PPR mode might be similar to the following sequence:

```
CALL ibrpp (brd0%, ppr%)
CALL ibrpp (brd0%, ppr%)
IF ppr > 0 GOTO 300
```

Selecting a PPR Mode

To select a PPR mode, consider the type of Controller present in your GPIB system and the length of cable between the GPIB-140A extenders. However, if your application does not use parallel polls, you do not need to select a PPR mode.

Some Hewlett Packard GPIB Controllers remain in a parallel poll state with IDY asserted if they are not performing another function. A change in the response interrupts the application. In some Controllers, the IDY signal is toggled on and off, and you can change the duration of the signal to accommodate delayed responses over extenders. If you are using these types of Controllers, you should set the GPIB extender to immediate PPR mode.

Most other Controllers pulse the IDY signal for approximately 2 μ s and expect a response within that time. If you are using this type of Controller and if the cable between the extenders is longer than 60 m, you should set the GPIB extender to latched PPR mode. For shorter cable distances, use immediate PPR mode.

The two GPIB extenders in your extension system do not need to use the same PPR mode. Select the PPR mode of the local GPIB extender based on the Controllers on the local GPIB system. Likewise, select the PPR mode of the remote GPIB extender based on the Controllers on the remote GPIB system. If no Controllers are physically connected to one of the GPIB extenders, the PPR mode of that GPIB extender has no effect on your system.

Setting the PPR Mode

To use immediate PPR mode, set DIP switch 3 to the ON position, as shown in Figure 3-3. To use latched PPR mode, set DIP switch 3 to the OFF position.

Figure 3-3. DIP Switch Setting for Immediate PPR Mode

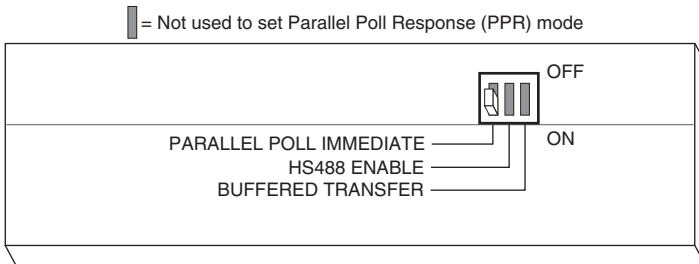

Using Your Extension System

After you supply power to both extenders and connect the fiber-optic cable, you can use your GPIB-140A or GPIB-140A/2 extension system.

Table 3-1 lists the three LEDs that indicate the operational status of each GPIB extender.

Table 3-1. GPIB-140A LEDs

LED	Description
POWER	Lights if power is supplied to the GPIB extender and the power switch is in the on position.
LINK	Lights if both GPIB extenders are powered on and the transmission cable is properly connected to both extenders. During operation, the LINK LED turns off if you disconnect the cable from the receiver of the GPIB extender, or if you power off either GPIB extender.
ERROR	Lights if the GPIB extender receives corrupted data. The ERROR LED turns off after the GPIB extender starts re-transmission and has received the first retransmitted data byte without error.

Theory of Operation

This chapter describes how the GPIB extender circuitry operates.

This chapter assumes that you are familiar with GPIB. If you are a first-time user or if you would like to review the basics about GPIB, refer to Appendix A, *GPIB Basics*.

Figure 4-1 shows the five layers of a GPIB extender. To form a complete link, you can connect each layer to the corresponding layer of another extender at the remote side.

Figure 4-1. GPIB Extender Block Diagram

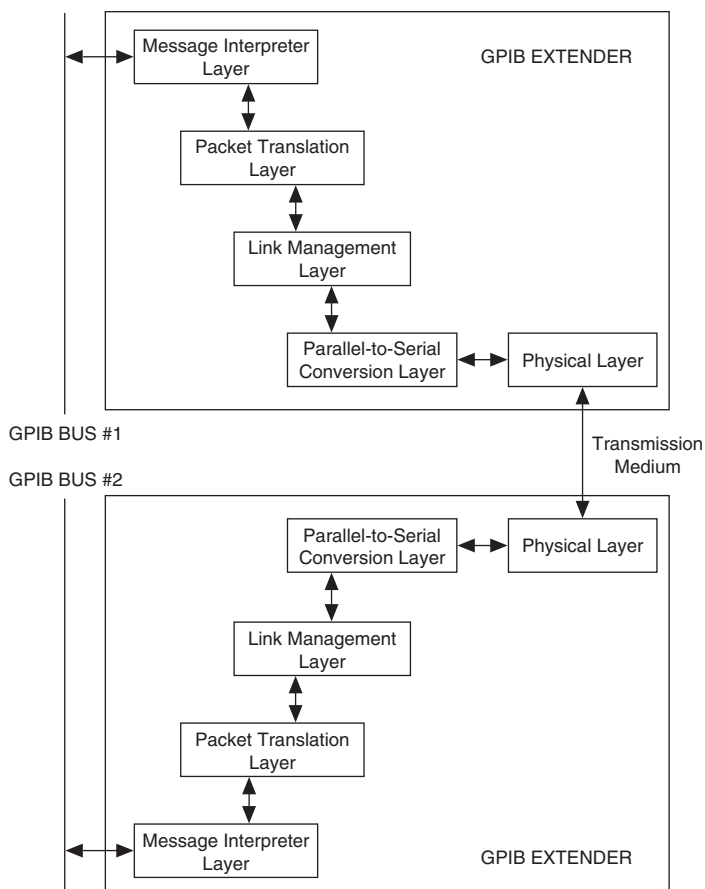

Message Interpreter Layer

The Message Interpreter Layer handles the handshake between the GPIB extender and other devices on the GPIB. At the same time, the layer monitors the activities that occur on the GPIB, translates them into equivalent local and remote GPIB messages, and sends these messages to the Packet Translation Layer.

Packet Translation Layer

The Packet Translation Layer converts the messages that it receives to packets and sends them to the Link Management Layer. It can also receive packets from the Link Management Layer and convert them back to local or remote GPIB messages.

Link Management Layer

The Link Management Layer receives packets from the Packet Translation Layer. It sends the packets to the Parallel-to-Serial Conversion Layer and it stores them in a local buffer. If a transmission error occurs, the Link Management Layer can re-send the packets from this local buffer. The Link Management Layer also receives packets from the Parallel-to-Serial Conversion Layer and checks the packets for transmission errors. If the Link Management Layer does not detect an error, it sends the packets to the Packet Translation Layer. However, if it detects a transmission error, the it re-transmits the packets.

Parallel-to-Serial Conversion Layer

The Parallel-to-Serial Conversion Layer accepts packets from the Link Management Layer, converts them into serial data, and sends the data to the Physical Layer. It also extracts serial bits from the Physical Layer, reconstructs them back into packets, and sends them to the Link Management Layer.

Physical Layer

The Physical Layer transmits and receives serial data over the fiber-optic link.

GPIB Basics

This appendix describes the basic concepts of GPIB, including its physical and electrical characteristics, and configuration requirements.

The ANSI/IEEE Standard 488.1-1987, also known as General Purpose Interface Bus (GPIB), describes a standard interface for communication between instruments and controllers from various vendors. It contains information about electrical, mechanical, and functional specifications. GPIB is a digital, 8-bit parallel communications interface with data transfer rates of 1 Mbyte/s and higher, using a three-wire handshake. The bus supports one System Controller, usually a computer, and up to 14 additional instruments. The ANSI/IEEE Standard 488.2-1992 extends IEEE 488.1 by defining a bus communication protocol, a common set of data codes and formats, and a generic set of common device commands.

Types of Messages

Interconnected GPIB devices communicate by passing messages through the interface system, including device-dependent messages and interface messages.

- Device-dependent messages, also called *data* or *data messages*, contain device-specific information, such as programming instructions, measurement results, machine status, and data files.
- Interface messages, also called *commands* or *command messages*, manage the bus itself. Interface messages initialize the bus, address and unaddress devices, and set device modes for remote or local programming.

The term *command* as used here does not refer to device instructions, which are also called commands. Those device-specific instructions are data messages.

Talkers, Listeners, and Controllers

GPIB devices can be Talkers, Listeners, or Controllers. A Talker sends out data messages. Listeners receive data messages. The Controller, usually a computer, manages the flow of information on the bus. It defines the communication links and sends GPIB commands to devices.

Some devices are capable of playing more than one role. A digital voltmeter, for example, can be a Talker and a Listener. If your system has a National Instruments GPIB interface and software installed, it can function as a Talker, Listener, and Controller.

The GPIB is like a typical computer bus, except that the typical computer has circuit cards interconnected via a backplane bus, whereas the GPIB has standalone devices interconnected via a cable bus.

The role of the GPIB Controller is similar to the role of the CPU of a computer, but a better analogy is to the switching center of a city telephone system. The switching center (Controller) monitors the communications network (GPIB). When the center (Controller) notices that a party (device) wants to make a call (send a data message), it connects the caller (Talker) to the receiver (Listener).

The Controller addresses a Talker and a Listener before the Talker can send its message to the Listener. After the message is transmitted, the Controller may unaddress both devices.

Some bus configurations do not require a Controller. For example, one device may always be a Talker (called a Talk-only device) and there may be one or more Listen-only devices.

A Controller is necessary when the active or addressed Talker or Listener must be changed. The Controller function is usually handled by a computer.

With the GPIB interface board and its software your personal computer plays all three roles.

- Controller—to manage the GPIB
- Talker—to send data
- Listener—to receive data

Controller-In-Charge and System Controller

You can have multiple Controllers on the GPIB, but only one Controller at a time can be the active Controller, or Controller-In-Charge (CIC). The CIC can be either active or inactive (standby). Control can pass from the current CIC to an idle Controller, but only the System Controller, usually a GPIB interface, can make itself the CIC.

GPIB Signals and Lines

Devices on the bus communicate by sending messages. Signals and lines transfer these messages across the GPIB interface, which consists of 16 signal lines and 8 ground return (shield drain) lines. The 16 signal lines are discussed in the following sections.

Data Lines

Eight data lines, DIO1 through DIO8, carry both data and command messages.

Handshake Lines

Three hardware handshake lines asynchronously control the transfer of message bytes between devices. This process is a three-wire interlocked handshake, and it guarantees that devices send and receive message bytes on the data lines without transmission error. Table A-1 summarizes the GPIB handshake lines.

Table A-1. GPIB Handshake Lines

Line	Description
NRFD (not ready for data)	Listening device is ready/not ready to receive a message byte. Also used by the Talker to signal high-speed GPIB transfers.
NDAC (not data accepted)	Listening device has/has not accepted a message byte.
DAV (data valid)	Talking device indicates signals on data lines are stable (valid) data.

Interface Management Lines

Five hardware lines manage the flow of information across the bus. Table A-2 summarizes the GPIB interface management lines.

Table A-2. GPIB Interface Management Lines

Line	Description
ATN (attention)	Controller drives ATN true when it sends commands and false when it sends data messages.
IFC (interface clear)	System Controller drives the IFC line to initialize the bus and make itself CIC.
REN (remote enable)	System Controller drives the REN line to place devices in remote or local program mode.
SRQ (service request)	Any device can drive the SRQ line to asynchronously request service from the Controller.
EOI (end or identify)	Talker uses the EOI line to mark the end of a data message. Controller uses the EOI line when it conducts a parallel poll.

Physical and Electrical Characteristics

Devices are usually connected with a cable assembly consisting of a shielded 24-conductor cable with both a plug and receptacle connector at each end, as shown in Figure A-1. With this design, you can link devices in a linear configuration, a star configuration, or a combination of the two configurations. Figure A-2 shows the linear and star configurations.

Figure A-1. GPIB Connector and the Signal Assignment

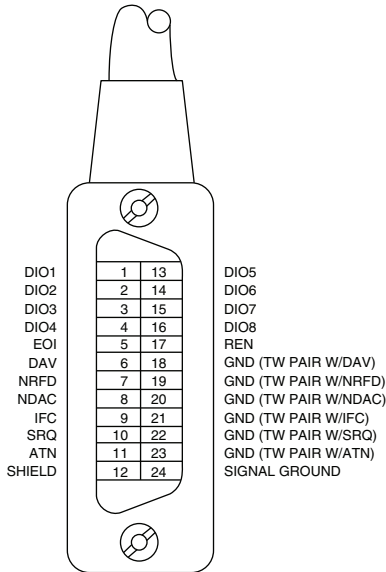
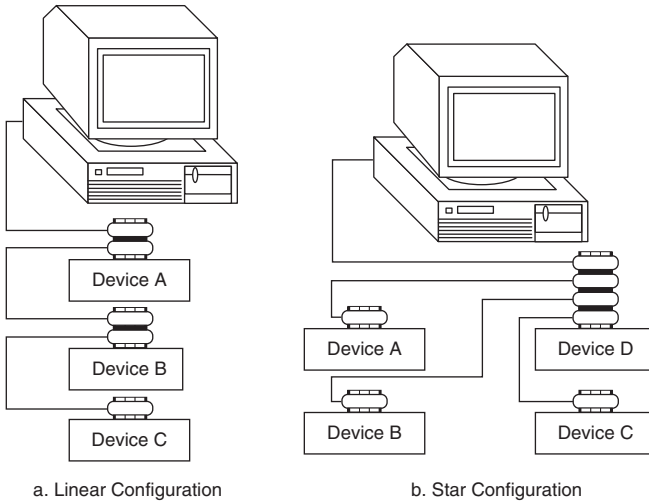

Figure A-2. Linear and Star System Configuration

The standard connector is the Amphenol or Cinch Series 57 *Microribbon* or *Amp Champ* type. For special interconnection applications, you use an adapter cable using a non-standard cable and/or connector.

The GPIB uses negative logic with standard TTL (transistor-transistor logic) level. For example, when DAV is true, it is a TTL low level (≤ 0.8 V), and when DAV is false, it is a TTL high level (≥ 2.0 V).

Configuration Requirements

To achieve the high data transfer rate that the GPIB was designed for, you must limit the number of devices on the bus and the physical distance between devices. The following restrictions are typical:

- A maximum separation of 4 m between any two devices and an average separation of 2 m over the entire bus.
- A maximum total cable length of 20 m.
- A maximum of 15 devices connected to each bus, with at least two-thirds powered on.

For high-speed operation, the following restrictions apply:

- All devices in the system must be powered on.
- Cable lengths must be as short as possible with up to a maximum of 15 m of cable for each system.
- There must be at least one equivalent device load per meter of cable.

If you want to exceed these limitations, you can use a bus expander to increase the number of device loads. You can order bus expanders from National Instruments.

Introduction to HS488

This appendix describes HS488 and the sequence of events in high-speed data transfers.

National Instruments has designed a high-speed data transfer protocol for IEEE 488 called HS488. This protocol increases performance for GPIB reads and writes up to 8 Mbytes/s, depending on your system.

If HS488 is enabled, the TNT4882C hardware implements high-speed transfers automatically when communicating with HS488 instruments. If you attempt to enable HS488 on a GPIB interface that does not have the TNT4882C hardware, the ECAP error code is returned.

Objectives

The following sections describe the objectives of HS488.

Faster Transfer Rates

HS488 enables transfer rates that are substantially faster than the IEEE 488 standard. In small systems, the raw transfer rate can be up to 8 Mbytes/s. The faster raw transfer rates improve system throughput in systems where devices send long blocks of data. The physical limitations of the cabling system, however, limit the transfer rate.

Compatibility with IEEE 488 Devices

HS488 is a superset of the IEEE 488 standard; thus, you can mix IEEE 488.1, IEEE 488.2, and HS488 devices in the same system.

When connected to an HS488 device, the Controller does not need to be capable of HS488 noninterlocked transfers. While ATN is asserted, the Controller sources multiline messages to HS488 devices just as it sources multiline messages to any IEEE 488 devices.

Automatic HS488 Detection

Addressed HS488 devices can detect whether other addressed devices are capable of HS488 transfers without the interaction of the Controller.

Compatibility with the IEEE 488.2 Standard

The HS488 protocol requires no changes to the IEEE 488.2 standard. Also, HS488 devices do not need to be compliant with IEEE 488.2.

Same Cabling Restrictions as IEEE 488.1

Systems that meet the IEEE 488.1 requirements for high-speed operation also meet the HS488 requirements. HS488 cabling requirements are also the same as the requirements in the IEEE 488.1 standard.

However, using HS488 does not reduce software overhead. Also, system throughput increases depend on data block size.

IEEE 488.1 Requirements for High-Speed Operation (T1 Delay \geq 350 ns)

The IEEE 488.1 standard requires that devices used in high-speed operation must use three-state, 48 mA drivers on most signals. Each device must add no more than 50 pF capacitance on each signal, and all devices must be powered on.

The total cable length in a system must be no more than 15 m, or 1 m times the number of devices in the system.

HS488 System Requirements

An HS488 system must meet the IEEE 488.1 requirements and it must implement the following three new interface functions:

- Talking devices must use the *Source Handshake Extended (SHE)* interface function, which is an extension of the IEEE 488.1 SH function.
- Listening devices must use the *Acceptor Handshake Extended (AHE)* interface function, which is an extension of the IEEE 488.1 AH function. Accepting devices must have a buffer of at least 3 bytes to store received data.
- HS488 devices must implement the *Configuration (CF)* interface function. At system power on, the Controller uses previously undefined multiline messages to configure HS488 devices. The CF function enables devices to interpret these multiline messages.

Sequence of Events in Data Transfers

Figure B-1 shows a typical IEEE 488.1 data transfer.

Figure B-1. IEEE 488.1 Transfers

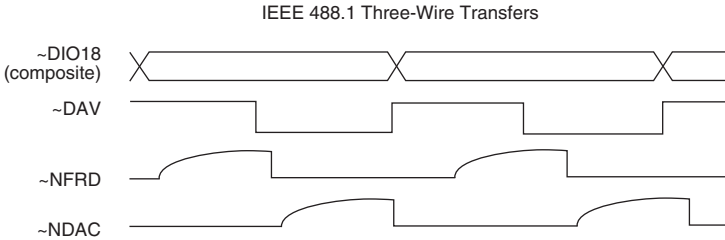
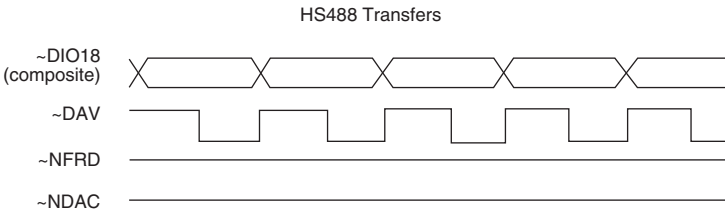

Figure B-2 shows an HS488 data transfer. The HS488 protocol modifies the IEEE 488.1 SH and AH functions. At the beginning of each data transfer, the HS488 SHE and AHE functions determine whether all active Talkers and Listeners are capable of HS488 transfers. If the addressed devices are HS488-capable, they use the HS488 noninterlocked handshake protocol for that data transfer. If any addressed device is not HS488-capable, the transfer continues using the standard three-wire handshake.

Figure B-2. HS488 Transfers



Case 1: Talker and Listener Are HS488-Capable

Figure B-3 and the following steps describe a typical sequence of events in an HS488 data transfer in which both the Talker and Listener are HS488-capable.

Figure B-3. HS488-Capable Talker and Listener

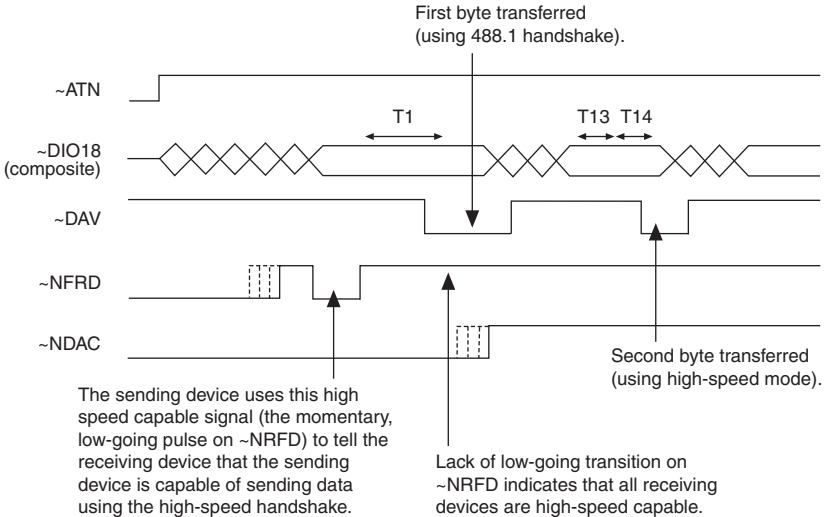

1. The Controller addresses devices and becomes Standby Controller by unasserting ATN.
2. The Listener asserts NDAC and NFRD.
3. The Listener unasserts NFRD as it becomes ready to accept a byte.
4. After allowing time for the Listener to detect NFRD unasserted, the Talker indicates that it is HS488-capable by sending the HSC message. To send the HSC message true, the Talker asserts the NFRD signal.
5. After allowing time for the Listener to respond to the HSC message, the Talker sends the HSC message false. To send the HSC message false, the Talker unasserts the NFRD signal.
6. When the Talker has a byte ready to send, it drives the data on the DIO signal lines, allows some settling time, and asserts DAV.
7. The Listener unasserts NDAC. HS488-capable Listeners do not assert NFRD as IEEE 488.1 devices would, so the Talker determines that the addressed Listener is HS488-capable.
8. The Talker unasserts DAV and drives the next data byte on the GPIB.
9. After allowing some settling time, the Talker asserts DAV.
10. The Listener latches the byte in response to the assertion (falling) edge of DAV.
11. After allowing some hold time, the Talker unasserts DAV and drives the next data byte on the DIO signal lines.
12. Steps 9-11 are repeated for each data byte.

Case 2: Talker Is HS488-Capable, But Listener Is Not HS488-Capable

Figure B-4 and the following steps describe a typical sequence of events in an HS488 data transfer in which the Talker is HS488-capable, but the Listener is not.

Figure B-4. HS488-Capable Talker

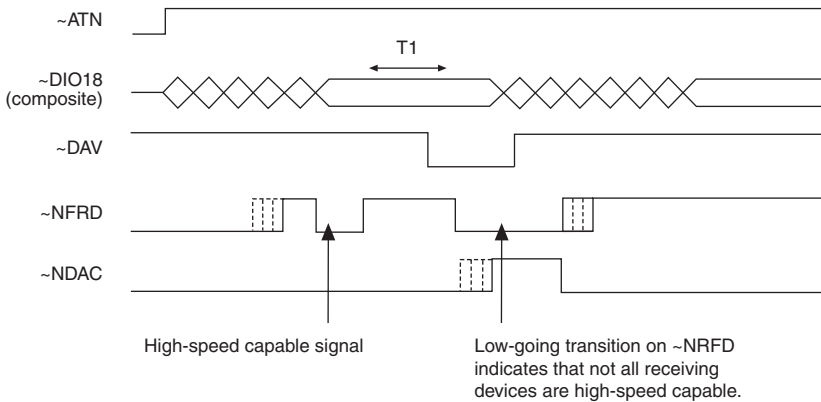

Steps 1-6 are identical to steps 1-6 in [Case 1: Talker and Listener Are HS488-Capable](#). The Listener ignores the HSC message from the Talker.

Then, the IEEE 488.1 Listener enters ACDS and asserts NRFD. As a result, the Talker determines that the addressed Listener is not HS488-capable. The Talker sources bytes using the IEEE 488.1 protocol.

Case 3: Talker Is Not HS488-Capable, But Listener Is HS488-Capable

The Talker does *not* send an HSC message to the Listener, but sources bytes using the IEEE 488.1 protocol.

The addressed Listener (HS488 or IEEE 488.1) accepts bytes using the IEEE 488.1 standard three-wire handshake, as shown in Figure B-5.

Figure B-5. Listener Is HS488-Capable

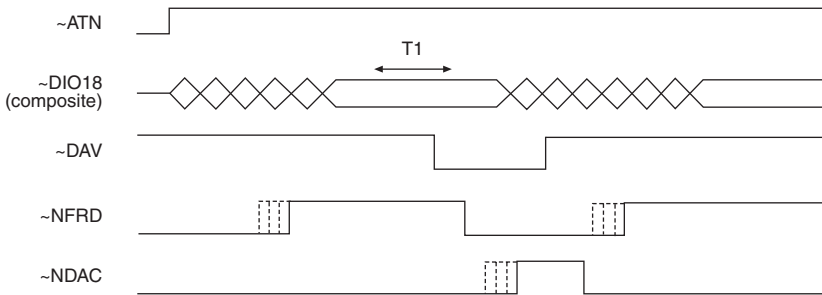

System Configuration

The HS488 AHE and SHE interface functions depend on several time delays. Some of these delays are a function of the total system cable length.

The Controller must communicate this system configuration data to HS488 devices after the system powers on. The Controller configures HS488 devices by sourcing the following two multiline messages while ATN is true:

- **Configuration Enable (CFE)**—The Controller sends the CFE message by driving a bit pattern (1E hex) that the IEEE 488.1 standard does not define on the DIO signal lines. The CFE message enables HS488 devices to interpret the SCG message that follows.
- **Secondary Command Group (SCG)**—This message contains the configuration data. The Secondary Command has the bit pattern 6n hex, where n is the meters of cable in the system. The SCG includes CFG1-CFG15 in Appendix C, [Multiline Interface Messages](#).

Multiline Interface Messages

This appendix lists the multiline interface messages and describes the mnemonics and messages that correspond to the interface functions.

The multiline interface messages are commands defined by the IEEE 488 standard. The messages are sent and received with ATN asserted. The interface functions include initializing the bus, addressing and unaddressing devices, and setting device modes for local or remote programming. For more information about these messages, refer to the ANSI/IEEE Standard 488.1-1987, *IEEE Standard Digital Interface for Programmable Instrumentation*.

Table C-1. Multiline Interface Messages

Hex	Dec	ASCII	Message
00	0	NUL	—
01	1	SOH	GTL
02	2	STX	—
03	3	ETX	—
04	4	EOT	SDC
05	5	ENQ	PPC
06	6	ACK	—
07	7	BEL	—
08	8	BS	GET
09	9	HT	TCT
0A	10	LF	—
0B	11	VT	—
0C	12	FF	—
0D	13	CR	—
0E	14	SO	—
0F	15	SI	—
10	16	DLE	—
11	17	DC1	LLO
12	18	DC2	—
13	19	DC3	—

Hex	Dec	ASCII	Message
20	32	SP	MLA0
21	33	!	MLA1
22	34	"	MLA2
23	35	#	MLA3
24	36	\$	MLA4
25	37	%	MLA5
26	38	&	MLA6
27	39	'	MLA7
28	40	(MLA8
29	41)	MLA9
2A	42	*	MLA10
2B	43	+	MLA11
2C	44	,	MLA12
2D	45	-	MLA13
2E	46	.	MLA14
2F	47	/	MLA15
30	48	0	MLA16
31	49	1	MLA17
32	50	2	MLA18
33	51	3	MLA19

Table C-1. Multiline Interface Messages (Continued)

Hex	Dec	ASCII	Message
14	20	DC4	DCL
15	21	NAK	PPU
16	22	SYN	—
17	23	ETB	—
18	24	CAN	SPE
19	25	EM	SPD
1A	26	SUB	—
1B	27	ESC	—
1C	28	FS	—
1D	29	GS	—
1E	30	RS	—
1F	31	US	CFE
40	64	@	MTA0
41	65	A	MTA1
42	66	B	MTA2
43	67	C	MTA3
44	68	D	MTA4
45	69	E	MTA5
46	70	F	MTA6
47	71	G	MTA7
48	72	H	MTA8
49	73	I	MTA9
4A	74	J	MTA10
4B	75	K	MTA11
4C	76	L	MTA12
4D	77	M	MTA13
4E	78	N	MTA14
4F	79	O	MTA15
50	80	P	MTA16
51	81	Q	MTA17
52	82	R	MTA18

Hex	Dec	ASCII	Message
34	52	4	MLA20
35	53	5	MLA21
36	54	6	MLA22
37	55	7	MLA23
38	56	8	MLA24
39	57	9	MLA25
3A	58	:	MLA26
3B	59	;	MLA27
3C	60	<	MLA28
3D	61	=	MLA29
3E	62	>	MLA30
3F	63	?	UNL
60	96	`	MSA0, PPE
61	97	a	MSA1, PPE, CFG1
62	98	b	MSA2, PPE, CFG2
63	99	c	MSA3, PPE, CFG3
64	100	d	MSA4, PPE, CFG4
65	101	e	MSA5, PPE, CFG5
66	102	f	MSA6, PPE, CFG6
67	103	g	MSA7, PPE, CFG7
68	104	h	MSA8, PPE, CFG8
69	105	i	MSA9, PPE, CFG9
6A	106	j	MSA10, PPE, CFG10
6B	107	k	MSA11, PPE, CFG11
6C	108	l	MSA12, PPE, CFG12
6D	109	m	MSA13, PPE, CFG13
6E	110	n	MSA14, PPE, CFG14
6F	111	o	MSA15, PPE, CFG15
70	112	p	MSA16, PPD
71	113	q	MSA17, PPD
72	114	r	MSA18, PPD

Table C-1. Multiline Interface Messages (Continued)

Hex	Dec	ASCII	Message
53	83	S	MTA19
54	84	T	MTA20
55	85	U	MTA21
56	86	V	MTA22
57	87	W	MTA23
58	88	X	MTA24
59	89	Y	MTA25
5A	90	Z	MTA26
5B	91	[MTA27
5C	92	\	MTA28
5D	93]	MTA29
5E	94	^	MTA30
5F	95	_	UNT

Hex	Dec	ASCII	Message
73	115	s	MSA19, PPD
74	116	t	MSA20, PPD
75	117	u	MSA21, PPD
76	118	v	MSA22, PPD
77	119	w	MSA23, PPD
78	120	x	MSA24, PPD
79	121	y	MSA25, PPD
7A	122	z	MSA26, PPD
7B	123	{	MSA27, PPD
7C	124		MSA28, PPD
7D	125	}	MSA29, PPD
7E	126	~	MSA30, PPD
7F	127	DEL	—

Multiline Interface Message Definitions			
CFE *	Configuration Enable	PPD	Parallel Poll Disable
CFG *	Configure	PPE	Parallel Poll Enable
DCL	Device Clear	PPU	Parallel Poll Unconfigure
GET	Group Execute Trigger	SDC	Selected Device Clear
GTL	Go To Local	SPD	Serial Poll Disable
LLO	Local Lockout	SPE	Serial Poll Enable
MLA	My Listen Address	TCT	Take Control
MSA	My Secondary Address	UNL	Unlisten
MTA	My Talk Address	UNT	Untalk
PPC	Parallel Poll Configure		
*This multiline interface message is a proposed extension to the IEEE 488 specification to support the HS488 protocol.			

Specifications

This appendix lists the specifications and characteristics of the GPIB extender.

System Configuration

Distance per extension	
GPIB-140A	Up to 1 km
GPIB-140A/2	Up to 2 km
Loading per extension	Up to 13 additional devices (28 total devices in the extension system, including the extenders)
Multiple extensions	Permitted in any combination of star or linear pattern

Performance Characteristics

Maximum transfer rate	
Buffered mode, non-HS488	> 1.1 Mbytes/s
HS488 handshake	> 2.8 Mbytes/s
Unbuffered mode	> 200 kbytes/s
Functionality	Transparent GPIB operation except for latched parallel polls
Interlocked IEEE 488 handshake	Maintained across the extension in unbuffered mode
IEEE 488 capability identification codes	
SH1	Complete Source Handshake
AH1	Complete Acceptor Handshake
T5, TE5	Complete Talker
L3, LE3	Complete Listener
SR1	Complete Service Request
RL1	Complete Remote Local
PP1, 2	Complete Parallel Poll
DC1	Complete Device Clear
DT1	Complete Device Trigger
C1-5	Complete Controller
E2	Tri-state GPIB driver
HS488 capability identification codes	
SHE	HS488 Source Handshake
AHE	HS488 Acceptor Handshake

Operational Characteristics

Architecture	Point-to-point (not multi-drop) transmission
Operating modes	Buffered or unbuffered (interlocked) mode
HS488 modes	Enabled HS488 or disabled HS488 mode
Parallel Poll Response modes	Immediate Parallel Poll Response mode or latched Parallel Poll Response mode

Electrical Characteristics

Transmission interface unit

GPIB-140A	Optical transmitter and receiver (HFBR1414, HFBR2416, or equivalent) with ST-style optical cable connectors
GPIB-140A/2	Optical transmitter and receiver (HFBR1312, HFBR1316, or equivalent) with ST-style optical cable connectors

GPIB interface load Two standard loads, AC and DC

Power supply unit

100-120 VAC	50-60 Hz
220-240 VAC	50-60 Hz

Maximum current requirement

100-120 VAC	135 mA
220-240 VAC	100 mA

Fuse rating and type

100-120 VAC	T 0.5A 250V
220-240 VAC	T 0.3A 350V

Environmental Characteristics

Operating temperature	0 to 40 °C
Storage temperature	-20 to 70 °C
Relative humidity	10% to 90%, noncondensing

Environmental Specifications

EMI	FCC Class A Verified
Maximum altitude	2,000 m (800 mbar), at 25 °C ambient temperature
Pollution Degree	2
Indoor use only.	

Physical Characteristics

Overall case size (dimensions)	3.5 × 5.65 × 1.62 in. (8.89 × 14.35 × 4.11 cm)
Case material	All metal enclosure
Weight	0.55 lb (0.25 kg)
GPIB cable	Type X2 shielded ¹
Transmission cable	
GPIB-140A	3.0 × 6.5 mm cable diameter 62.5/125 micron core/clad with NA = 0.275 850 nm operating wavelength 3.0 dB/km attenuation Duplex style, terminated with ST-style connectors
GPIB-140A/2	3.0 × 6.5 mm cable diameter 62.5/125 micron core/clad with NA = 0.275 1300 nm operating wavelength 1 dB/km attenuation Duplex style, terminated with ST-style connectors



Caution Clean the hardware with a soft, nonmetallic brush. Make sure that the hardware is completely dry and free from contaminants before returning it to service.

¹ To meet FCC emission limits for this device, you must use a shielded GPIB cable. If you operate this equipment with a non-shielded cable, it may interfere with radio and television reception.

Safety

This product is designed to meet the requirements of the following standards of safety for information technology equipment:

- IEC 60950-1, EN 60950-1
- UL 60950-1, CSA 60950-1



Caution The protection provided by the GPIB 140A can be impaired if it is used in a manner not described in this document.



Note For UL and other safety certifications, refer to the product label or the *Online Product Certification* section.

Electromagnetic Compatibility

This product meets the requirements of the following EMC standards for electrical equipment for measurement, control, and laboratory use:

- EN 61326 (IEC 61326): Class A emissions; Basic immunity
- EN 55011 (CISPR 11): Group 1, Class A emissions
- AS/NZS CISPR 11: Group 1, Class A emissions
- FCC 47 CFR Part 15B: Class A emissions
- ICES-001: Class A emissions



Note For the standards applied to assess the EMC of this product, refer to the *Online Product Certification* section.



Note For EMC compliance, operate this device with shielded cabling.

CE Compliance

This product meets the essential requirements of applicable European Directives as follows:

- 2006/95/EC; Low-Voltage Directive (safety)
- 2004/108/EC; Electromagnetic Compatibility Directive (EMC)

Online Product Certification

Refer to the product Declaration of Conformity (DoC) for additional regulatory compliance information. To obtain product certifications and the DoC for this product, visit ni.com/certification, search by model number or product line, and click the appropriate link in the Certification column.

Environmental Management

NI is committed to designing and manufacturing products in an environmentally responsible manner. NI recognizes that eliminating certain hazardous substances from our products is beneficial to the environment and to NI customers.

For additional environmental information, refer to the *Minimize Our Environmental Impact* web page at ni.com/environment. This page contains the environmental regulations and directives with which NI complies, as well as other environmental information not included in this document.

Waste Electrical and Electronic Equipment (WEEE)



EU Customers At the end of the product life cycle, all products *must* be sent to a WEEE recycling center. For more information about WEEE recycling centers, National Instruments WEEE initiatives, and compliance with WEEE Directive 2002/96/EC on Waste and Electronic Equipment, visit ni.com/environment/weee.

电子信息产品污染控制管理办法（中国 RoHS）



中国客户 National Instruments 符合中国电子信息产品中限制使用某些有害物质指令 (RoHS)。关于 National Instruments 中国 RoHS 合规性信息，请登录 ni.com/environment/rohs_china。(For information about China RoHS compliance, go to ni.com/environment/rohs_china.)

Technical Support and Professional Services

Log in to your National Instruments ni.com User Profile to get personalized access to your services. Visit the following sections of ni.com for technical support and professional services:

- **Support**—Technical support at ni.com/support includes the following resources:
 - **Self-Help Technical Resources**—For answers and solutions, visit ni.com/support for software drivers and updates, a searchable KnowledgeBase, product manuals, step-by-step troubleshooting wizards, thousands of example programs, tutorials, application notes, instrument drivers, and so on. Registered users also receive access to the NI Discussion Forums at ni.com/forums. NI Applications Engineers make sure every question submitted online receives an answer.
 - **Standard Service Program Membership**—This program entitles members to direct access to NI Applications Engineers via phone and email for one-to-one technical support, as well as exclusive access to self-paced online training modules at ni.com/self-paced-training. All customers automatically receive a one-year membership in the Standard Service Program (SSP) with the purchase of most software products and bundles including NI Developer Suite. NI also offers flexible extended contract options that guarantee your SSP benefits are available without interruption for as long as you need them. Visit ni.com/ssp for more information.
For information about other technical support options in your area, visit ni.com/services, or contact your local office at ni.com/contact.
- **Training and Certification**—Visit ni.com/training for training and certification program information. You can also register for instructor-led, hands-on courses at locations around the world.
- **System Integration**—If you have time constraints, limited in-house technical resources, or other project challenges, National Instruments Alliance Partner members can help. To learn more, call your local NI office or visit ni.com/alliance.

You also can visit the Worldwide Offices section of ni.com/niglobal to access the branch office Web sites, which provide up-to-date contact information, support phone numbers, email addresses, and current events.

Glossary

Symbol	Prefix	Value
p	pico	10^{-12}
n	nano	10^{-9}
μ	micro	10^{-6}
m	milli	10^{-3}
k	kilo	10^3
M	mega	10^6
G	giga	10^9
T	tera	10^{12}

Symbols

° degrees

% percent

A

A amperes

AC alternating current

AHE HS488 Acceptor Handshake Extended interface function

ANSI American National Standards Institute

ASCII American Standards Code for Information Interchange

ASIC application-specific integrated circuit

ATN Attention

Glossary

C

C	Celsius
CIC	Controller-In-Charge
CPU	central processing unit
CSA	Canadian Standards Association

D

DAV	data valid
dB	decibels
DC	direct current
DIO	digital input/output
DIP	dual inline package

E

EOI	End or Identify
EOS	End of String

F

F	Farads
FCC	Federal Communications Commission
FIFO	first-in-first-out

G

g grams

GPIB General Purpose Interface Bus

H

hex hexadecimal

Hz hertz

I

IDY Identify

IEC International Electrotechnical Commission

IEEE Institute of Electrical and Electronic Engineers

IFC Interface Clear

in. inches

L

lb pounds

LED light-emitting diode

M

m meters

S

s seconds

SHE HS488 Source Handshake Extended interface function

Glossary

T

TTL transistor-transistor logic

U

UL Underwriter's Laboratories

V

V volts

VAC volts alternating current