

RMX-410x

Rackmount Programmable DC Power Supplies

200W/400W/800W

Built-in USB, RS-232, RS-485, LAN Interface

USER MANUAL

This Manual Covers Models:

RMX-4101

RMX-4102

RMX-4104

Worldwide Support and Services

The NI website is your complete resource for technical support. At ni.com/support, you have access to everything from troubleshooting and application development self-help resources to email and phone assistance from NI Application Engineers.

Visit ni.com/services for information about the services NI offers.

Visit ni.com/register to register your NI product. Product registration facilitates technical support and ensures that you receive important information updates from NI.

NI corporate headquarters is located at 11500 North Mopac Expressway, Austin, Texas, 78759-3504, USA. For up-to-date contact information for your location, visit ni.com/contact.

© 2017-2020 National Instruments Corporation. All rights reserved.

Table of Contents

| | |
|--|-----------|
| CHAPTER 1: GENERAL INFORMATION | 13 |
| 1.1 User Manual Content | 13 |
| 1.2 Introduction..... | 13 |
| 1.2.1 General Description | 13 |
| 1.2.3 Features and Options | 13 |
| 1.2.4 Multiple Output Power System | 14 |
| 1.2.6 Analog Voltage Programming and Monitoring | 14 |
| 1.2.7 Parallel Operation | 14 |
| 1.2.8 Output Connections | 14 |
| 1.2.9 Cooling and Mechanical Construction | 14 |
| 1.3.1 General | 15 |
| 1.3.2 Serial Link Cable | 15 |
| 1.3.3 Misc. Hardware | 15 |
| 1.3.4 AC Cables | 15 |
| 1.3.5 Serial Port Cables | 15 |
| CHAPTER 2: SPECIFICATIONS | 16 |
| 2.1 RMX-4101 Series Specifications | 17 |
| 2.2 RMX-4102 Series Specifications..... | 21 |
| 2.3 RMX-4104 Series Specifications | 25 |
| 2.4 RMX-410x Mechanical..... | 28 |
| 2.4.1 Rackmount Dimensions..... | 29 |
| CHAPTER 3: INSTALLATION | 30 |
| 3.1 General | 30 |
| 3.2 Preparation for Use | 30 |
| 3.3 Initial Inspection | 30 |
| 3.4 Rackmount..... | 30 |
| 3.5 Location, Mounting and Cooling..... | 31 |
| 3.5.1 Rackmount Installation | 31 |
| 3.6 AC Source Requirements | 32 |
| 3.7 AC Input Power Connection | 32 |
| 3.7.1 AC Input Connector | 33 |
| 3.7.2 AC Input Cord | 33 |
| 3.8 Turn-On Checkout Procedure | 33 |
| 3.8.1 General..... | 33 |
| 3.8.2 Prior to Operation..... | 33 |
| 3.8.3 Constant Voltage Check..... | 34 |
| 3.8.4 Constant Current Check | 34 |
| 3.8.5 OVP Check..... | 34 |
| 3.8.6 UVL Check | 34 |
| 3.8.7 Foldback Check | 35 |
| 3.9 Connecting the Load..... | 35 |
| 3.9.1 Load Wiring | 35 |
| 3.9.2 Current Carrying Capacity | 35 |
| 3.9.3 Wire Termination..... | 37 |
| 3.9.4 Noise and Impedance Effects | 37 |
| 3.9.5 Inductive Loads | 37 |
| 3.9.6 Making the Load Connections | 37 |
| 3.9.7 Connecting Single Loads, Local Sensing (default) | 39 |
| 3.9.8 Connecting Single Loads, Remote Sensing..... | 39 |
| 3.9.9 Connecting Multiple Loads, Radial Distribution Method..... | 40 |

| | |
|--|-----------|
| 3.9.10 Multiple Load Connection with Distribution Terminals..... | 40 |
| 3.9.11 Grounding Outputs | 41 |
| 3.10 Local and Remote Sensing..... | 41 |
| 3.10.1 Sense Wiring | 41 |
| 3.10.2 Local Sensing..... | 42 |
| 3.10.3 Remote Sensing..... | 42 |
| 3.10.4 J2 Sense Connector Technical Information | 43 |
| 3.11 Repackaging for Shipment..... | 43 |
| CHAPTER 4: FRONT/REAR PANEL CONTROLS AND CONNECTORS | 44 |
| 4.1 Introduction..... | 44 |
| 4.2 Front Panel Display and Controls | 44 |
| 4.3 Rear Panel Connectors | 46 |
| 4.3.1 J1 Connector Terminal and Function..... | 48 |
| 4.3.2 J3 Connector Terminal and Function | 49 |
| 4.4 Front Panel Display Messages..... | 50 |
| 4.5 Navigating the Main Menu | 51 |
| 4.5.1 Introduction..... | 51 |
| 4.5.2 Exiting the Main Menu..... | 52 |
| 4.6 Navigating Communication Menu..... | 52 |
| 4.6.1 Introduction..... | 52 |
| 4.6.2 Exiting the Communication Menu | 53 |
| 4.7 Navigating the Protection Menu | 53 |
| 4.7.1 Introduction | 53 |
| 4.7.2 Exiting the Protection Menu | 53 |
| CHAPTER 5: LOCAL OPERATION | 54 |
| 5.1 Introduction..... | 54 |
| 5.2 Standard Operation..... | 54 |
| 5.2.1 Constant Voltage Mode and Voltage Setting | 54 |
| 5.2.2 Constant Current Mode and Current Setting | 54 |
| 5.2.3 Automatic Crossover | 55 |
| 5.2.4 Output On/Off Control | 55 |
| 5.2.5 Safe Start and Auto-Restart Modes..... | 55 |
| 5.2.6 Viewing Software Revision..... | 55 |
| 5.3 Alarms and Protective Functions..... | 56 |
| 5.3.1 Introduction | 56 |
| 5.3.2 Over Voltage Protection..... | 56 |
| 5.3.2.1 Setting the OVP Level | 56 |
| 5.3.2.2 Resetting the OVP Circuit..... | 57 |
| 5.3.3 Under Voltage Protection and Under Voltage Limit | 57 |
| 5.3.3.1 Setting the UVP/UVL Mode and Level | 57 |
| 5.3.3.2 Activated UVP Alarm..... | 57 |
| 5.3.4 Foldback Protection | 57 |
| 5.3.4.1 Setting the Foldback Protection..... | 58 |
| 5.3.4.2 Activated FOLD Alarm..... | 58 |
| 5.3.5 Protection Delay..... | 58 |
| 5.3.5.1 Setting the Protection Delay | 58 |
| 5.3.6 Over Temperature Protection | 58 |
| 5.3.7 AC Fail Alarm..... | 58 |
| 5.4 Series Operation | 59 |
| 5.4.1 Series Connection for Increased Output Voltage..... | 59 |
| 5.4.2 Series Connection for Positive and Negative Output Voltage | 60 |
| 5.4.3 Remote Programming in Series Operation | 60 |

| | |
|---|----|
| 5.5 Parallel Operation..... | 61 |
| 5.5.1 Introduction..... | 61 |
| 5.5.2 Basic Parallel Operation..... | 61 |
| 5.5.2.1 Master Unit Set Up..... | 61 |
| 5.5.2.2 Slave Unit Set Up..... | 62 |
| 5.5.2.3 Setting Over Voltage Protection..... | 62 |
| 5.5.2.4 Setting Foldback Protection..... | 62 |
| 5.5.2.5 Connection to Load..... | 62 |
| 5.5.3 Advanced Parallel Operation..... | 64 |
| 5.5.3.1 Master Unit Set Up..... | 64 |
| 5.5.3.2 Slave Unit Set Up..... | 64 |
| 5.6 Daisy-Chain Connection..... | 65 |
| 5.7 Rear Panel (J3 Connector) Functions and Settings..... | 65 |
| 5.7.1 External Shut Off Function..... | 66 |
| 5.7.2 Interlock Function - Analog On/Off. (Enable/Disable)..... | 66 |
| 5.7.3 Auxiliary Programmed Function Pin 1 and Pin 2..... | 67 |
| 5.7.4 Power Supply OK Signal..... | 68 |
| 5.8 Rear Panel (J1 Connector) Functions..... | 68 |
| 5.8.1 CV/CC Signal..... | 68 |
| 5.9 Parameter Setting Memory..... | 69 |
| 5.9.1 Default Setting..... | 69 |
| 5.9.2 Reset..... | 69 |
| 5.9.3 Last Setting Memory..... | 69 |
| 5.9.4 Save <1..4>..... | 70 |
| 5.9.5 Recall <1..4>..... | 70 |

CHAPTER 6: REMOTE ANALOG PROGRAMMING 72

| | |
|--|----|
| 6.1 Introduction..... | 72 |
| 6.2 Local/Remote Analog Control..... | 72 |
| 6.3 Local/Remote Analog Indication..... | 72 |
| 6.4 Remote Voltage Programming of Output Voltage and Current..... | 73 |
| 6.5 Remote Resistor Programming of Output Voltage and Output Current..... | 74 |
| 6.6 Programming Monitoring of Output Voltage (V_MON) and Current (I_MON).... | 75 |

CHAPTER 7: Serial RS232/RS485 and USB Interface 76

| | |
|---|----|
| 7.1 Introduction..... | 76 |
| 7.2 Configuration..... | 76 |
| 7.2.1 Default Setting..... | 76 |
| 7.2.2 Address Setting..... | 76 |
| 7.2.3 Communication Interface Selection..... | 76 |
| 7.2.4 Baud Rate Setting..... | 77 |
| 7.2.5 Language Selection (RS232/RS485, USB)..... | 77 |
| 7.2.6 Setting Unit in Remote, Local Lockout or Local Mode..... | 77 |
| 7.3 Rear Panel RS232/485 Connector..... | 78 |
| 7.4 Connecting Power Supply To RS232 Or RS485 BUS..... | 79 |
| 7.5 Rear Panel USB Connector..... | 80 |
| 7.5.1 USB Getting Started..... | 80 |
| 7.6 Multi Power Supply Connection to RS232, RS485, LAN, or USB..... | 80 |
| 7.7 GEN Protocol (GEN series communication language)..... | 81 |
| 7.7.1 Data Format..... | 81 |
| 7.7.2 End of Message..... | 81 |
| 7.7.3 Command Repeat..... | 81 |
| 7.7.4 Checksum..... | 81 |
| 7.7.5 Acknowledge..... | 81 |

| | |
|--|-----|
| 7.7.6 Backspace | 81 |
| 7.7.7 Error Messages | 81 |
| 7.8 GEN Command Set Description | 82 |
| 7.8.1 General guides | 82 |
| 7.8.2 Command Set Categories | 82 |
| 7.8.3 Identification Commands | 82 |
| 7.8.4 Initialization Commands | 83 |
| 7.8.5 Output Commands | 83 |
| 7.8.6 Global Output Commands | 85 |
| 7.8.7 Auxiliary Commands | 87 |
| 7.8.8 Status Commands | 87 |
| 7.9 Serial Communication Test Set-Up | 88 |
| 7.10 SCPI Protocol | 88 |
| 7.10.1 Data Format | 88 |
| 7.10.2 End of Message | 88 |
| 7.10.3 End of Command | 88 |
| 7.10.4 Checksum | 89 |
| 7.10.5 SCPI Requirements | 89 |
| 7.10.6 SCPI Command Hierarchy | 89 |
| 7.10.7 Header | 89 |
| 7.10.8 Data Formats | 90 |
| 7.10.9 Character Data | 90 |
| 7.10.10 Commands Notes | 90 |
| 7.11 SCPI Common Commands | 90 |
| 7.12 SCPI Subsystem Commands | 95 |
| 7.12.1 Output Subsystem | 95 |
| 7.12.2 Instrument Subsystem | 98 |
| 7.12.3 Voltage Subsystem | 98 |
| 7.12.4 Current Subsystem | 100 |
| 7.12.5 Measure Subsystem | 101 |
| 7.12.6 DISPlay Subsystem | 102 |
| 7.12.7 INITiate Subsystem | 103 |
| 7.12.8 LIST Subsystem | 103 |
| 7.12.9 STATus Subsystem | 105 |
| 7.12.10 SYSTem Subsystem | 107 |
| 7.12.11 TRIGger Subsystem | 108 |
| 7.12.12 WAVE Subsystem | 109 |
| 7.12.13 Global Subsystem | 110 |
| 7.13 Command Summary | 111 |

CHAPTER 8: ADVANCED FUNCTIONS

115

| | |
|---|-----|
| 8.1 Introduction | 115 |
| 8.2 FIX Mode | 115 |
| 8.3 LIST Mode | 116 |
| 8.4 WAVE Mode | 117 |
| 8.5 Trigger | 118 |
| 8.5.1 Input Trigger | 118 |
| 8.5.2 Output Trigger | 119 |
| 8.6 Transient Waveform Example | 119 |
| 8.6.1 Wave Programing | 119 |
| 8.6.2 Wave Execution via Communication PC | 119 |
| 8.6.3 Wave Execution via Front Panel | 120 |
| 8.7 Additional Examples | 120 |
| 8.7.1 List Example | 120 |

| | |
|---|------------|
| 8.7.2 Waveform Example | 120 |
| CHAPTER 9: STATUS, FAULT AND SRQ REGISTERS | 121 |
| 9.1 General | 121 |
| 9.2 Power Supply Status Structure | 122 |
| 9.3 Condition Registers | 122 |
| 9.3.1 Fault Register | 122 |
| 9.3.2 Status Register | 123 |
| 9.4 Conditional, Enable and Event Registers | 123 |
| 9.4.1 Conditional Registers..... | 123 |
| 9.4.2 Event Registers..... | 123 |
| 9.4.3 Enable Register | 123 |
| 9.5 Service Request | 123 |
| 9.6 Standard Event Status Group..... | 124 |
| 9.6.1 Register Functions | 124 |
| 9.6.2 Register Commands..... | 124 |
| CHAPTER 10: MAINTENANCE | 125 |
| 10.1 Introduction..... | 125 |
| 10.2 Units Under Warranty..... | 125 |
| 10.3 Periodic Maintenance..... | 125 |
| 10.4 Adjustments and Calibration | 125 |
| 10.5 Parts Replacement and Repairs | 125 |
| 10.6 Troubleshooting | 125 |
| 10.7 Fuse Rating | 126 |
| USER MANUAL INDEX | 127 |

Electromagnetic Compatibility Guidelines

This product was tested and complies with the regulatory requirements and limits for electromagnetic compatibility (EMC) stated in the product specifications. These requirements and limits provide reasonable protection against harmful interference when the product is operated in the intended operational electromagnetic environment.

This product is intended for use in industrial locations. However, harmful interference may occur in some installations, when the product is connected to a peripheral device or test object, or if the product is used in residential or commercial areas. To minimize interference with radio and television reception and prevent unacceptable performance degradation, install and use this product in strict accordance with the instructions in the product documentation.

Furthermore, any changes or modifications to the product not expressly approved by NI could void your authority to operate it under your local regulatory rules.

Safety

This product is designed to meet the requirements of the following standards of safety for test and measurement equipment:

* IEC 61010-1, EN 61010-1

* UL 61010-1, CSA 61010-1

Note: For UL and other safety certifications, refer to the product label or the Online Product Certification section.

Electromagnetic Compatibility

This product meets the requirements of the following EMC standards for electrical equipment for measurement, control, and laboratory use:

* EN 61326-1 (IEC 61326-1): Class A emissions; Basic immunity

* EN 55011 (CISPR 11): Group 1, Class A emissions

* EN 55022 (CISPR 22): Class A emissions

* EN 55024 (CISPR 24): Immunity

* AS/NZS CISPR 11: Group 1, Class A emissions

* AS/NZS CISPR 22: Class A emissions

* FCC 47 CFR Part 15B: Class A emissions

* ICES-001: Class A emissions

Note: In the United States (per FCC 47 CFR), Class A equipment is intended for use in commercial, light-industrial, and heavy-industrial locations. In Europe, Canada, Australia and New Zealand (per CISPR 11) Class A equipment is intended for use only in heavy-industrial locations.

Note: Group 1 equipment (per CISPR 11) is any industrial, scientific, or medical equipment that does not intentionally generate radio frequency energy for the treatment of material or inspection/analysis purposes.

Note: For EMC declarations and certifications, and additional information, refer to the Online Product Certification section.

CE Compliance

This product meets the essential requirements of applicable European Directives as follows:

* 2014/35/EC; Low-Voltage Directive (safety)

* 2014/30/EU; Electromagnetic Compatibility Directive (EMC)

Online Product Certification

Refer to the product Declaration of Conformity (DoC) for additional regulatory compliance information. To obtain product certifications and the DoC for this product, visit ni.com/certification, search by model number or product line, and click the appropriate link in the Certification column.

Environmental Management

NI is committed to designing and manufacturing products in an environmentally responsible manner. NI recognizes that eliminating certain hazardous substances from our products is beneficial to the environment and to NI customers.

For additional environmental information, refer to the NI and the Environment Web page at ni.com/environment. This page contains the environmental regulations and directives with which NI complies, as well as other environmental information not included in this document.



Waste Electrical and Electronic Equipment (WEEE)

EU Customers: At the end of the product life cycle, all products must be sent to a WEEE recycling center. For more information about WEEE recycling centers, NI WEEE initiatives, and compliance with WEEE Directive 2002/96/EC on Waste and Electronic Equipment, visit ni.com/environment/weee.

电子信息产品污染控制管理办法（中国 RoHS）



中国客户 National Instruments 符合中国电子信息产品中限制使用某些有害物质指令 (RoHS)。

关于 National Instruments 中国 RoHS 合规性信息，请登录 ni.com/environment/rohs_china。(For information about China RoHS compliance, go to ni.com/environment/rohs_china.)

CAUTION:

RMX-410x series units are not authorized for use as critical component in nuclear control systems, life support systems or equipment for use in hazardous environments without the express written approval of NI.

OVERVOLTAGE CATEGORY AND ENVIRONMENTAL CONDITIONS

The RMX-410x series units have been evaluated to Overvoltage category II.

The RMX-410x series units are intended for use in the following operation conditions:

- * Indoor use
- * Pollution degree 2
- * Max. operational altitude: 3000m above sea level
- * Ambient temperature: 0°C-50°C.

GROUNDING

RMX-410X series units are Class I product. To minimize electrical shock hazard, the RMX-410x series units must be connected to an electrical ground. The instruments must be connected to the AC power supply mains through a standard certified three-wire power cable, with the ground wire firmly connected to an electrical ground (safety ground) at the power outlet. Any interruption of the protective ground conductor or disconnection of the protective earth terminal will cause a potential shock hazard that might cause personal injury.

LIVE CIRCUITS

Operating personnel must not remove the RMX-410x series unit cover.

No internal adjustment or component replacement is allowed by non-NI qualified service personnel. Never replace components with power cable connected. To avoid injuries, always disconnect power, discharge circuits and remove external voltage sources before touching components.

PARTS SUBSTITUTIONS & MODIFICATIONS

Parts substitutions and modifications are by authorized NI service personnel only. For repairs or modifications, the instrument must be returned to NI service facility.

AC INPUT

Do not connect RMX-410x series unit to mains supply exceeding the input voltage and frequency rating. The input voltage and frequency rating is: 100-240V~, 50/60Hz. For safety reasons, the mains supply voltage fluctuations should not exceed +/-10% of nominal voltage.

ENERGY HAZARD

The main output of RMX-410x series units is capable of providing hazardous energy. Due to hazardous energy level the output and connections therefore must not be user accessible. Manufacturer's final equipment must provide protection to service personnel against inadvertent contact with output bus bars.

FUSE

Internal fuse is sized for fault protection and if a fuse was opened it would indicate that service is required. Fuse replacement should be made by qualified technical personnel. Refer to maintenance instructions in Chapter 10 for fuse ratings.

WARNING:











There is electric shock hazard when the power supply output is adjusted above 60VDC. Ensure that there is no possibility to touch simultaneously one of the output pins and earth (including the power supply's metal enclosure) nor to touch simultaneously one of the output pins and metal parts of any external products supplied by the power supply when the output is adjusted above 60VDC.

Note: The protection provided by the RMX-410x can be impaired if it is used in a manner not described in this document.

WARNING:

There is a potential shock hazard when using a power supply with an output voltage greater than 60VDC. Do not turn ON power supply when output voltage is above 60VDC without output bus-bars and output connectors protection assembled. Turn OFF power supply or disconnect power supply from AC mains before making or changing any rear panel connection.

SYMBOLS

| | |
|---|--|
|  | <p>Caution, risk of danger. Instruction manual symbol. The instrument will be marked with this symbol when it is necessary for the user to refer to the instruction manual.</p> |
|  | <p>Indicates ground terminal.</p> |
|  | <p>Protective Conductor Terminal.</p> |
|  | <p>ON (Supply).</p> |
|  | <p>OFF (Supply).</p> |
|  | <p>Standby (Supply) .</p> |
|  | <p>Direct current (DC).</p> |
|  | <p>Alternate current (AC).</p> |
|  | <p>Denotes hazard. An attention to a procedure is called. Not following the procedure correctly could result in personal injury. A WARNING sign should not be skipped and all indicated conditions must be fully understood and met.</p> |
|  | <p>Denotes hazard. An attention to a procedure is called. Not following the procedure correctly could result in damage to the equipment.</p> |

CHAPTER 1: GENERAL INFORMATION

1.1 User Manual Content

This user's manual contains the operating instructions, installation instructions and specifications of the RMX-410x Series 200W, 400W, and 800W power supply series. The instructions refer to the standard power supplies, including the built-in USB and RS232/485 serial communication. For information related to operation with the LAN, refer to User Manual for power supply LAN.

1.2 Introduction

1.2.1 General Description

RMX-410x Series power supplies are wide output range, high performance switching power supplies. The RMX-410x Series is power factor corrected and operates from worldwide AC voltage range continuously. Output voltage and current are continuously displayed and LED indicators show the complete operating status of the power supply. The Front Panel controls allow the user to set the output parameters, the protection levels (Over-Voltage protection, Under-Voltage protection and Foldback) and preview the settings. The rear panel includes the necessary connectors to control and monitor the power supply operation by remote analog signals or by the built-in serial communication USB, LAN, and RS232/485.

1.2.2 Models Covered by this Manual

| Model | Voltage range (V) | Current range (A) | Model | Voltage range (V) | Current range (A) |
|----------|-------------------|-------------------|----------|-------------------|-------------------|
| RMX-4101 | 0-20 | 0-10 | RMX-4101 | 0-60 | 0-3.5 |
| RMX-4102 | 0-20 | 0-20 | RMX-4102 | 0-60 | 0-7 |
| RMX-4104 | 0-20 | 0-40 | RMX-4104 | 0-60 | 0-14 |
| RMX-4101 | 0-36 | 0-6 | RMX-4101 | 0-100 | 0-2 |
| RMX-4102 | 0-36 | 0-12 | RMX-4102 | 0-100 | 0-4 |
| RMX-4104 | 0-36 | 0-24 | RMX-4104 | 0-100 | 0-8 |

1.2.3 Features and Options

- Constant Voltage / Constant Current with automatic crossover.
- Active Power Factor correction.
- Universal Input Voltage 85-265Vac, continuous operation.
- Embedded Microprocessor Controller.
- Built in USB & RS232/485 Interface.
- Voltage & Current high resolution adjustment by digital Encoders.
- High resolution 16 bit ADCs & DACs.
- Software Calibration (no internal trimmers / potentiometers).
- Last Setting Memory.
- Independent Remote ON/OFF (Opto-Isolated) and Remote Enable/Disable.
- Parallel operation (Master/Slave) with Active current sharing.
- Remote sensing to compensate for voltage drop of power leads.
- External Analog Programming and Monitoring (0-5V or 0-10V, user selectable).
- Cooling fan speed control for low noise and extended fan life.
- LAN interface (SCPI compatible).

1.2.4 Multiple Output Power System

The RMX-410x Series power supplies series can be configured into a programmable power system of up to 31 units using the built-in LAN, USB or RS232/RS485 communication port in the power supply and the RS485 linking cable provided with each power supply. In a LAN system, each power supply can be controlled using the LAN controller (installed).

1.2.5 Control via the USB or RS232/485 Communication Ports

The following parameters can be programmed via the serial communication port:

- Output voltage setting.
- Output current setting.
- Output voltage measurement.
- Output current measurement.
- Output on/off control.
- Foldback protection setting.
- Over-voltage protection setting and readback.
- Under-Voltage protection setting and readback.
- Under-Voltage limit setting and read back.
- Power-supply start up mode (last setting or safe mode).

1.2.6 Analog Voltage Programming and Monitoring

Analog inputs and outputs are provided at the rear panel for analog control of the power supply. The output voltage and the current limit can be programmed by analog voltage or by resistor, and can be monitored by analog voltage. The power supply output can be remotely set to On or Off and analog signals monitor the proper operation of the power supply and the mode of operation (CV/CC).

1.2.7 Parallel Operation

Up to six RMX-410x Series power supplies of the same output voltage and current rating can be paralleled in master-slave configuration with automatic current sharing to increase available power.

1.2.8 Output Connections

Output connections are made to rear panel bus-bars. Either the positive or negative terminal may be grounded or the output may be floated. The power supplies shall not float outputs more than +/- 100VDC above / below chassis ground. Contact factory for assistance with higher float voltage applications.

Local or remote sense may be used. In remote sense, the voltage drop on the load wires should be minimized. Refer to the specifications for the maximum voltage drop value.

1.2.9 Cooling and Mechanical Construction

The RMX-410x Series is cooled by an internal fan. At installation, care must be taken to allow free air flow into the power supply via the front panel, and out of the power supply via the rear panel. The RMX-410x Series power supply is a compact and lightweight unit which allows for easy installation and gives a space saving solution for customer applications.

CAUTION:

Observe all torque guidelines within this manual. Over torque may damage unit or accessories. Such damage is not covered under manufacturers warranty.

1.3 Accessories

1.3.1 General

Accessories are delivered with the power supply or separately upon ordering, the list below shows the possible accessories and ordering numbers.

1.3.2 Serial Link Cable

Serial link cable, for linking power supplies by RS485 communication is provided with the power supply.

Cable description: 0.5m length, shielded, RJ-45 type plugs, 8 contacts (P/N: 786188-01).

1.3.3 Misc. Hardware

- **Bus bars protection**
- **Connector protection**
- **Connector housing IPD1-06-D-K(SAMTEC)**
- **Connector housing IPD1-04-D-K(SAMTEC)**
- **Connector housing IPD1-02-D-K(SAMTEC)**
- **Contact pins P/N: CC79R-2024-01-L(SAMTEC)**
- **Rackmount kit for RMX-410x 2U DC power supplies, holds six supplies. P/N: 786186-01**
- **Blank panel for RMX-410x rackmount kit. P/N: 786187-01**

1.3.4 AC Cables

AC cables are not provided with the power supply. If an AC cable is required, it should be ordered according to the following:

| Part no. | Description |
|------------|--|
| 786204-1R5 | POWER CORD, AC, IEC C15 to C14, 100-240V, 1.5M North America |
| 786204-2R5 | POWER CORD, AC, IEC C15 to C14, 100-240V, 2.5M North America |
| 786206-1R5 | POWER CORD, AC, IEC C15 to C14, 100-240V, 1.5M Europe |
| 786206-2R5 | POWER CORD, AC, IEC C15 to C14, 100-240V, 2.5M Europe |
| 786205-1R5 | POWER CORD, AC, IEC C15 to C14, 100-240V, 1.5M Korea |
| 786205-2R5 | POWER CORD, AC, IEC C15 to C14, 100-240V, 2.5M Korea |
| 786207-1R5 | POWER CORD, AC, IEC C15 to C14, 100-240V, 1.5M China |
| 786207-2R5 | POWER CORD, AC, IEC C15 to C14, 100-240V, 2.5M China |
| 786208-1R5 | POWER CORD, AC, IEC C15 to C14, 100-240V, 1.5M Japan |
| 786208-2R5 | POWER CORD, AC, IEC C15 to C14, 100-240V, 2.5M Japan |
| 786209-02 | POWER CORD, AC, IEC C15 to NEMA 5-15P, 13A, 2.5m |
| 786212-02 | POWER CORD, AC, IEC C15 to Euro, 240V, 2.5m |
| 786213-02 | POWER CORD, AC, IEC C15 to UK, 240V, 2.5m |
| 786211-02 | POWER CORD, AC, IEC C15 to Korea, 240V, 2.5m |
| 786214-02 | POWER CORD, AC, IEC C15 to China, 240V, 2.5m |
| 786210-02 | POWER CORD, AC, IEC C15 to Japan, 110V, 2.5m |

1.3.5 Serial Port Cables

If a serial port cable is required, it should be ordered according to the description in section 7.2

* USB cables are not provided with the power supply.

CHAPTER 2: SPECIFICATIONS

2.1 RMX-4101 Series Specifications

| MODEL | RMX-4101 | | | | | |
|------------------------------|----------|-------|------|--------|-------|--|
| | N/A | 20-10 | 36-6 | 60-3.5 | 100-2 | |
| 1. Rated output voltage(*1) | V | 20 | 36 | 60 | 100 | |
| 2. Rated output current (*2) | A | 10 | 6 | 3.5 | 2 | |
| 3. Rated output power | W | 200 | 216 | 210 | 200 | |

| CONSTANT VOLTAGE MODE | | RMX-4101 | | | | | |
|---|--------------------------|---|-------|------|--------|-------|--|
| | | N/A | 20-10 | 36-6 | 60-3.5 | 100-2 | |
| 1. Max. Line regulation (*6) | --- | 0.01% of rated output voltage+2mV | | | | | |
| 2. Max. Load regulation (*7) | --- | 0.01% of rated output voltage+2mV | | | | | |
| 3. Ripple and noise (p-p, 20MHz) (*8) | mV | | 50 | 50 | 50 | 80 | |
| 4. Ripple r.m.s. 5Hz~1MHz | mV | | 6 | 6 | 7 | 8 | |
| 5. Temperature coefficient | PPM/°C | 30PPM/°C from rated output voltage, following 30 minutes warm-up. | | | | | |
| 6. Temperature stability | --- | 0.02% of rated Vout over 8hrs. interval following 30 minutes warm-up. Constant line, load & temp. | | | | | |
| 7. Warm-up drift | --- | Less than 0.05% of rated output voltage+2mV over 30 minutes following power on. | | | | | |
| 8. Remote sense compensation/wire | V | | 1 | 2 | 3 | 5 | |
| 9. Up-prog. Response time, 0~Vomax.(*9) | mS | | 30 | 30 | 50 | 50 | |
| 10. Down-prog. response time: | Full load (*9) | | 25 | 30 | 40 | 50 | |
| | Time delay (*17) | mS | 250 | 320 | 380 | 1200 | |
| | No load (*10) (*15)(*17) | | 65 | 85 | 100 | 250 | |
| | No load (*10) (*16)(*17) | | 200 | 290 | 310 | 1100 | |
| 11. Transient response time | mS | Time for output voltage to recover within 0.5% of its rated output for a load change 10~90% of rated output current. Output set-point: 10~100%, Local sense Less than 1mS, for models up to and including 100V | | | | | |
| 12. Hold-up time (*19) | --- | 16mSec Typical. | | | | | |
| 1. Max. Line regulation (*6) | --- | 0.01% of rated output current+2mA | | | | | |
| 2. Max. Load regulation (*11) | --- | 0.01% of rated output current+5mA | | | | | |
| 3. Load regulation thermal drift | --- | Less than 0.05% of rated output current over 30 minutes following load change. | | | | | |
| 4. Ripple r.m.s. 5Hz~1MHz | mA | | 15 | 8 | 4 | 3 | |
| 5. Temperature coefficient | PPM/°C | 100PPM/°C from rated output current, following 30 minutes warm-up. | | | | | |
| 6. Temperature stability | --- | 0.05% of rated Iout over 8hrs. interval following 30 minutes warm-up. Constant line, load & temperature. | | | | | |
| 7. Warm-up drift | --- | Less than +/-0.1% of rated output current over 30 minutes following power on. | | | | | |

| PROTECTIVE FUNCTIONS | | RMX-4101 | | | | | |
|--|-----|---|-------|------|--------|-------|--|
| | | N/A | 20-10 | 36-6 | 60-3.5 | 100-2 | |
| 1. Foldback protection | --- | Output shut-down when power supply change mode from CV to CC or CC to CV. User presetable. Reset by AC input recycle in autostart mode or by OUTPUT button or by rear panel ENABLE, or by communication port. | | | | | |
| 2. Over-voltage protection (OVP) | --- | Inverter Shut down method. Reset by AC input recycle in autostart mode or by OUTPUT button or by rear panel ENABLE, or by communication port. | | | | | |
| 3. Over -voltage trip point | V | | 1~24 | 2~40 | 5~66 | 5~110 | |
| 4. Output under voltage limit (UVL) | --- | Preset by front panel or communication port. Prevents from adjusting Vout below limit. Does not affect in analog programming. | | | | | |
| 5. Output under voltage protection (UVP) | --- | Output shut-down when power supply output voltage goes below UVP programming. User presetable. Reset by AC input recycle in autostart mode or by OUTPUT button or by rear panel ENABLE, or by communication port. | | | | | |
| 6. Over temperature protection | --- | User selectable, latched or non latched. | | | | | |

| ANALOG PROGRAMMING AND MONITORING | | |
|---|-----|--|
| 1. Vout voltage programming | --- | 0~100%, 0~5V or 0~10V, user selectable. Accuracy and linearity: +/-0.5% of rated Vout. |
| 2. Iout voltage programming (*13) | --- | 0~100%, 0~5V or 0~10V, user selectable. Accuracy and linearity: +/-1% of rated Iout. |
| 3. Vout resistor programming | --- | 0~100%, 0~5/10Kohm full scale, user selectable. Accuracy and linearity: +/-1% of rated Vout. |
| 4. Iout resistor programming (*13) | --- | 0~100%, 0~5/10Kohm full scale, user selectable. Accuracy and linearity: +/-1.5% of rated Iout. |
| 5. Shut Off (SO) control | --- | By electrical Voltage: 0~0.6V/4~15V or dry contact, user selectable logic. |
| 6. Output current monitor (*13) | --- | 0~5V or 0~10V, user selectable. Accuracy: +/-1%. |
| 7. Output voltage monitor | --- | 0~5V or 0~10V, user selectable. Accuracy: +/-1%. |
| 8. Power supply OK signal | --- | 4~5V-OK, 0V-Fail. 500ohm series resistance. |
| 9. Parallel operation (*20) | --- | Possible, up to 6 units in master/slave mode with single wire current balance connection. |
| 10. Series operation | --- | 2 identical units (with external diodes). |
| 11. CV/CC indicator | --- | Open collector. CC mode: On, CV mode: Off. Maximum voltage: 30V, maximum sink current: 10mA |
| 12. Interlock (ILC) control | --- | Enables/Disables the PS output by dry contact (Short: On, Open: Off, Source current: less than 0.5mA). Ena/Dis is activated by front panel. |
| 13. Local/Remote mode Control | --- | By electrical signal or Open/Short: 0~0.6V or short: Remote, 2~15V or open: Local |
| 14. Local/Remote mode Indicator | --- | Open collector (shunted by 36V zener). On (0~0.6V, 10mA sink current max.)-Remote. Off-Local (30V max.). |
| 15. Trigger out | --- | Maximum low level output =0.8V, Minimum high level output =3.8V, Maximum high level output =5V, Maximum source current =16mA, pulse =20µs Typical. |
| 16. Trigger in | --- | Maximum low level input =1.2V, Minimum high level input =3.5V, Maximum high level input =5V, Maximum sink current =16mA, positive edge, trigger: tw =10µs minimum, Tr/Tf =1µs maximum. |
| 17. Programmed signal 1 | --- | Open collector, maximum voltage 25V, maximum sink current 100mA. (Shunted by 27V zener) |
| 18. Programmed signal 2 | --- | Open collector, maximum voltage 25V, maximum sink current 100mA. (Shunted by 27V zener) |
| FRONT PANEL | | |
| 1. Control functions | --- | Multiple options with 2 Encoders |
| | --- | Vout/Iout manual adjust |
| | --- | OVP/UVL/UVP manual adjust |
| | --- | Protection Functions - OVP, UVL, UVP, Foldback, OCP, INT, SO |
| | --- | Communication Functions - Selection of LAN, RS232, RS485, USB |
| | --- | Communication Functions - Selection of Baud Rate, Address |
| | --- | Analog Control Functions - Selection Voltage/resistive programming, 5V/10V, 5K/10K programming |
| 2. Display | --- | Vout: 4 digits, accuracy: 0.5% of rated output voltage +/-1 count. |
| | --- | Iout: 4 digits, accuracy: 0.5% of rated output current +/-1 count. |
| 3. Indications | --- | GREEN LEDs: FINE, MENU, PREV, PROT, REM, OUTPUT, CV, CC |
| | --- | RED LED: PROT (OVP, UVP, OTP, FOLD, AC FAIL). |
| 4. Function buttons | --- | FINE, MENU, PREV, PROT, REM, OUTPUT |
| PROGRAMMING AND READBACK (RS232/485, USB, LAN) | | |
| 1. Vout programming accuracy | --- | 0.05% of rated output voltage |
| 2. Iout programming accuracy (*13) | --- | 0.1% of actual +0.1% of rated output current |
| 3. Vout programming resolution | --- | 0.012% of full scale |
| 4. Iout programming resolution | --- | 0.012% of full scale |
| 5. Vout readback accuracy | --- | 0.05% of rated output voltage |
| 6. Iout readback accuracy (*13) | --- | 0.1% of actual +0.3% of rated output current |
| 7. Vout readback resolution | --- | 0.012% of full scale |
| 8. Iout readback resolution | --- | 0.012% of full scale |

RMX-4101 Series Specifications

RMX-4101

| INPUT CHARACTERISTICS | | 20-10 | 36-6 | 60-3.5 | 100-2 |
|--|-----|---|-----------|-----------|-----------|
| 1. Input voltage/freq. (*3) | --- | 85~265Vac continuous, 47~63Hz, single phase | | | |
| 2. Maximum Input current 100/200VAC (*4) (*18) | --- | 2.62/1.29 | 2.76/1.37 | 2.69/1.33 | 2.55/1.26 |
| 3. Power Factor (Typ) | --- | >0.99 at 100Vac, >0.98 at 200Vac, 100% load | | | |
| 4. Efficiency (Typ) 100/200VAC (*4) (*18) | % | 77/79 | 79/80.5 | 79/80.5 | 79/81 |
| 5. Inrush current 100/200VAC (*5) | --- | Less than 15A/30A | | | |

ENVIRONMENTAL CONDITIONS

| | | |
|--------------------------|-----|---|
| 1. Operating temperature | --- | 0~50°C, 100% load. |
| 2. Storage temperature | --- | -20~85°C |
| 3. Operating humidity | % | 20~90% RH (no condensation). |
| 4. Storage humidity | % | 10~95% RH (no condensation). |
| 5. Altitude | --- | Maximum 3000m. Derate ambient temp above 2000m. Operating: Maximum ambient temperature, From 2000m up to 3000m Ambient temperature 40°C. |

SAFETY/EMC

| | | | |
|--------------------------|--------|-----|--|
| 1. Applicable standards: | Safety | --- | IEC61010-1, UL61010-1, CSA22.2, No.61010-1, EN61010-1. 10V≤Vout≤60V: Output,J1,J2,J3,J4,USB,LAN,IEEE/ISOLATED Analog are Non Hazardous Vout=100V:Output,J1,J2 are Hazardous J3,J4,USB, IEEE/ISOLATED Analog ,LAN are Non Hazardous |
| | EMC | --- | IEC/EN61326-1 (Built to meet EN55022/EN55024) |
| 2. Withstand voltage | | --- | 10≤Vout≤36V models: Input-Output&J1,J2,J3,J4,USB,LAN/IEEE/ISOLATED ANALOG: 4242VDC/1min; Input-Ground: 2828VDC/1min. Output&J1,J2,J3,J4,USB,LAN/IEEE/ISOLATED ANALOG-Ground: 707VDC/1min. 60V,100V models: Input-Output&J1,J2: 4242VDC/1min; Input-J3,J4,USB,LAN/IEEE/ISOLATED Analog: 4242VDC/1min; Input-Ground: 2828VDC/1min. Output&J1,J2-J3,J4,USB,LAN/IEEE/ISOLATED ANALOG :1910VDC/1min; Output&J1,J2-Ground: 1380VDC/1min. J3, J4, USB/LAN/IEEE/ISOLATED ANALOG - Ground: 707VDC/1min; |
| 3. Insulation resistance | | --- | More than 100Mohm at 25°C, 70%RH. |
| 4. Conducted emission | | --- | IEC/EN61326-1 Industrial Location - B, FCC part 15-B, VCCI-B |
| 5. Radiated emission | | --- | IEC/EN61326-1 Industrial Location - A, FCC part 15-A, VCCI-A |

MECHANICAL

| | | | |
|-----------------------|----------|-----|--|
| 1. Cooling | | --- | Forced air cooling by internal fan. |
| 2. Weight | STANDARD | Kg | Less than 1.9Kg. |
| 3. Dimensions (WxHxD) | STANDARD | mm | H: 83, W: 70, D: 350 (excluding bus bars, handles...). (Refer to Outline drawing). |

NOTES:

- *1: Minimum voltage is guaranteed to maximum 0.1% of rated output voltage.
- *2: Minimum current is guaranteed to maximum 0.2% of rated output current.
- *3: For cases where conformance to various safety standards (UL, IEC, etc...) is required, to be described as 100-240Vac (50/60Hz).
- *4: Ta=25°C with rated output power.
- *5: Not including EMI filter inrush current, less than 0.2mSec at cold start Ta=25°C
- *6: At 85~132Vac or 170~265VAC, constant load.
- *7: From No-Load to Full-Load, constant input voltage. Measured at the sensing point in Remote Sense.
- *8: Measured with JEITA RC-9131A (1:1) probe.
- *9: From 10% to 90% or 90% to 10% of Rated Output Voltage, with rated resistive load.
- *10: From 90% to 10% of Rated Output Voltage.
- *11: For load voltage change, equal to the unit voltage rating, constant input voltage.
- *13: The Constant Current programming, readback and monitoring accuracy do not include the warm-up and Load regulation thermal drift.
- *14: Measured with JEITA RC-9131A (1:1) probe.
- *15: For cases where the time interval between each down programming is longer than Td (time delay).
- *16: For cases where the time interval between each down programming is shorter than Td (time delay).
- *17: Td typical Minimum time between consecutive down programming cycles.
- *18: PS with LAN and models decrease efficiency by 0.5% and increase input current by 0.5%.
- *19: At rated output power.
- *20: For Parallel operation more than 2 units 5% of total output current is required.

2.2 RMX-4102 Series Specifications

| | | RMX-4102 | | | | |
|------------------------------|---|----------|-------|-------|------|-------|
| MODEL | | N/A | 20-20 | 36-12 | 60-7 | 100-4 |
| 1. Rated output voltage(*1) | V | | 20 | 36 | 60 | 100 |
| 2. Rated output current (*2) | A | | 20 | 12 | 7 | 4 |
| 3. Rated output power | W | | 400 | 432 | 420 | 400 |

| CONSTANT VOLTAGE MODE | | | 20-20 | 36-12 | 60-7 | 100-4 |
|---|---------------------------|-----|---|-------|------|-------|
| 1. Max. Line regulation (*6) | | --- | 0.01% of rated output voltage+2mV | | | |
| 2. Max. Load regulation (*7) | | --- | 0.01% of rated output voltage+2mV | | | |
| 3. Ripple and noise (p-p, 20MHz) (*8) | mV | | 50 | 50 | 50 | 80 |
| 4. Ripple r.m.s. 5Hz~1MHz | mV | | 6 | 6 | 7 | 8 |
| 5. Temperature coefficient | PPM/°C | | 30PPM/°C from rated output voltage, following 30 minutes warm-up. | | | |
| 6. Temperature stability | | --- | 0.02% of rated Vout over 8hrs. interval following 30 minutes warm-up. Constant line, load & temp. | | | |
| 7. Warm-up drift | | --- | Less than 0.05% of rated output voltage+2mV over 30 minutes following power on. | | | |
| 8. Remote sense compensation/wire | V | | 1 | 2 | 3 | 5 |
| 9. Up-prog. Response time, 0~Vomax.(*9) | mS | | 30 | 30 | 50 | 50 |
| 10. Down-prog. response time: | Full load (*9) | | 10 | 15 | 30 | 50 |
| | Time delay (*17) | mS | 250 | 320 | 380 | 1200 |
| | No load (*10) (*15) (*17) | | 65 | 85 | 100 | 250 |
| | No load (*10) (*16) (*17) | | 200 | 290 | 310 | 1100 |
| 11. Transient response time | mS | | Time for output voltage to recover within 0.5% of its rated output for a load change 10~90% of rated output current. Output set-point: 10~100%, Local sense. Less than 1mS, for models up to and including 100V | | | |
| 12. Hold-up time (*19) | | --- | 16mSec Typical. | | | |

| CONSTANT CURRENT MODE | | | 20-20 | 36-12 | 60-7 | 100-4 |
|----------------------------------|--------|-----|--|-------|------|-------|
| 1. Max. Line regulation (*6) | | --- | 0.01% of rated output current+2mA | | | |
| 2. Max. Load regulation (*11) | | --- | 0.01% of rated output current+5mA | | | |
| 3. Load regulation thermal drift | | --- | Less than 0.05% of rated output current over 30 minutes following load change. | | | |
| 4. Ripple r.m.s. 5Hz~1MHz | mA | | 40 | 15 | 8 | 3 |
| 5. Temperature coefficient | PPM/°C | | 100PPM/°C from rated output current, following 30 minutes warm-up. | | | |
| 6. Temperature stability | | --- | 0.05% of rated Iout over 8hrs. interval following 30 minutes warm-up. Constant line, load & temperature. | | | |
| 7. Warm-up drift | | --- | Less than +/-0.1% of rated output current over 30 minutes following power on. | | | |

| PROTECTIVE FUNCTIONS | | | 20-20 | 36-12 | 60-7 | 100-4 |
|--|---|-----|--|-------|------|-------|
| 1. Foldback protection | | --- | Output shut-down when power supply change mode from CV to CC or CC to CV. User presetable. Reset by AC input recycle in autostart mode or by OUTPUT button or by rear panel ENABLE, or by communication port. | | | |
| 2. Over-voltage protection (OVP) | | --- | Inverter Shut down method. Reset by AC input recycle in autostart mode or by OUTPUT button or by rear panel ENABLE, or by communication port. | | | |
| 3. Over - voltage trip point | V | | 1~24 | 2~40 | 5~66 | 5~110 |
| 4. Output under voltage limit (UVL) | | --- | Preset by front panel or communication port. Prevents from adjusting Vout below limit. Does not affect in analog programming. | | | |
| 5. Output under voltage protection (UVP) | | --- | Output shut-down when power supply output voltage goes below UVP programming. User presetable. Reset by AC input recycle in autostart mode or by OUTPUT button or by rear panel ENABLE, or by communication port. | | | |
| 6. Over temperature protection | | --- | User Selectable. Latched or non latched | | | |

| ANALOG PROGRAMMING AND MONITORING | | |
|------------------------------------|-----|--|
| 1. Vout voltage programming | --- | 0~100%, 0~5V or 0~10V, user selectable. Accuracy and linearity: +/-0.5% of rated Vout. |
| 2. Iout voltage programming (*13) | --- | 0~100%, 0~5V or 0~10V, user selectable. Accuracy and linearity: +/-1% of rated Iout. |
| 3. Vout resistor programming | --- | 0~100%, 0~5/10Kohm full scale, user selectable. Accuracy and linearity: +/-1% of rated Vout. |
| 4. Iout resistor programming (*13) | --- | 0~100%, 0~5/10Kohm full scale, user selectable. Accuracy and linearity: +/-1.5% of rated Iout. |
| 5. Shut Off (SO) control | --- | By electrical Voltage: 0~0.6V/4~15V or dry contact, user selectable logic. |
| 6. Output current monitor (*13) | --- | 0~5V or 0~10V, user selectable. Accuracy: +/-1%. |
| 7. Output voltage monitor | --- | 0~5V or 0~10V, user selectable. Accuracy: +/-1%. |
| 8. Power supply OK signal | --- | 4~5V-OK, 0V-Fail. 500ohm series resistance. |
| 9. Parallel operation (*21) | --- | Possible, up to 6 units in master/slave mode with single wire current balance connection. |
| 10. Series operation | --- | 2 identical units (with external diodes). |
| 11. CV/CC indicator | --- | Open collector. CC mode: On, CV mode: Off. Maximum voltage: 30V, maximum sink current: 10mA |
| 12. Interlock (ILC) control | --- | Enables/Disables the PS output by dry contact (Short: On, Open: Off, Source current: less than 0.5mA). Ena/Dis is activated by front panel. |
| 13. Local/Remote mode Control | --- | By electrical signal or Open/Short: 0~0.6V or short: Remote, 2~15V or open: Local |
| 14. Local/Remote mode Indicator | --- | Open collector (shunted by 36V zener). On (0~0.6V, 10mA sink current max.)-Remote. Off-Local (30V max.). |
| 15. Trigger out | --- | Maximum low level output =0.8V, Minimum high level output =3.8V, Maximum high level output =5V, Maximum source current =16mA, pulse =20µs Typical. |
| 16. Trigger in | --- | Maximum low level input =1.2V, Minimum high level input =3.5V, Maximum high level input =5V, Maximum sink current =16mA, positive edge, trigger: tw =10µs minimum, Tr/Tf =1µs maximum. |
| 17. Programmed signal 1 | --- | Open collector, maximum voltage 25V, maximum sink current 100mA. (Shunted by 27V zener) |
| 18. Programmed signal 2 | --- | Open collector, maximum voltage 25V, maximum sink current 100mA. (Shunted by 27V zener) |

| FRONT PANEL | | |
|----------------------|-----|--|
| 1. Control functions | --- | Multiple options with 2 Encoders |
| | --- | Vout/Iout manual adjust |
| | --- | OVP/UVL /UVP manual adjust |
| | --- | Protection Functions - OVP, UVL, UVP, Foldback, OCP, INT, SO |
| | --- | Communication Functions - Selection of LAN,IEEE (*20), RS232,RS485,USB |
| | --- | Communication Functions - Selection of Baud Rate, Address |
| | --- | Analog Control Functions - Selection Voltage/resistive programming, 5V/10V, 5K/10K programming |
| 2. Display | --- | Vout: 4 digits, accuracy: 0.5% of rated output voltage+/-1 count. |
| | --- | Iout: 4 digits, accuracy: 0.5% of rated output current+/-1 count. |
| 3. Indications | --- | GREEN LEDs: FINE, MENU, PREV, PROT, REM, OUTPUT, CV, CC |
| | --- | RED LED: PROT (OVP, UVP, OTP, FOLD, AC FAIL). |
| 4. Function buttons | --- | FINE, MENU, PREV, PROT, REM, OUTPUT |

| PROGRAMMING AND READBACK (RS232/485,USB, LAN) | | |
|---|-----|--|
| 1. Vout programming accuracy | --- | 0.05% of rated output voltage |
| 2. Iout programming accuracy (*13) | --- | 0.1% of actual +0.1% of rated output current |
| 3. Vout programming resolution | --- | 0.012% of full scale |
| 4. Iout programming resolution | --- | 0.012% of full scale |
| 5. Vout readback accuracy | --- | 0.05% of rated output voltage |
| 6. Iout readback accuracy (*13) | --- | 0.1% of actual +0.3% of rated output current |
| 7. Vout readback resolution | --- | 0.012% of full scale |
| 8. Iout readback resolution | --- | 0.012% of full scale |

RMX-4102 Series Specifications

| | | RMX-4102 | | | | |
|--|-----|---|-----------|-----------|-----------|-----------|
| INPUT CHARACTERISTICS | | | 20-20 | 36-12 | 60-7 | 100-4 |
| 1. Input voltage/freq. (*3) | --- | 85~265Vac continuous, 47~63Hz, single phase | | | | |
| 2. Maximum Input current 100/200VAC (*4) (*18) | --- | | 4.98/2.45 | 5.25/2.57 | 5.10/2.50 | 4.80/2.37 |
| 3. Power Factor (Typ) | --- | 0.99 at 100/200Vac, 100% load | | | | |
| 4. Efficiency (Typ) 100/200VAC (*4) (*18) | % | | 81/83 | 83/85 | 83/85 | 84/86 |
| 5. Inrush current (*5) | --- | Less than 25A | | | | |

| ENVIRONMENTAL CONDITIONS | | |
|--------------------------|-----|---|
| 1. Operating temperature | --- | 0~50°C, 100% load. |
| 2. Storage temperature | --- | -20~85°C |
| 3. Operating humidity | % | 20~90% RH (no condensation). |
| 4. Storage humidity | % | 10~95% RH (no condensation). |
| 5. Altitude | --- | Maximum 3000m. Derate ambient temp above 2000m. Operating: Maximum ambient temperature, From 2000m up to 3000m Ambient temperature 40°C. |

| SAFETY/EMC | | | |
|--------------------------|--------|-----|---|
| 1. Applicable standards: | Safety | --- | IEC61010-1, UL61010-1, CSA22.2 No.61010-1, EN61010-1. 10V≤Vout≤60V: Output,J1,J2,J3,J4,USB,LAN, are Non Hazardous Vout=100V:Output,J1,J2 are Hazardous J3,J4,USB, LAN are Non Hazardous |
| | EMC | --- | IEC/EN61326-1 (Built to meet EN55022/EN55024) |
| 2. Withstand voltage | | --- | 10≤Vout≤36V models: Input-Output&J1,J2,J3,J4,USB,LAN/ 4242VDC/1min; Input-Ground: 2828VDC/1min. Output&J1,J2,J3,J4,USB,LAN/Ground: 707VDC/1min. 60V,100V models: Input-Output&J1,J2: 4242VDC/1min; Input-J3,J4,USB,LAN 4242VDC/1min; Input-Ground: 2828VDC/1min. Output&J1,J2- J3,J4,USB,LAN/1910VDC/1min; Output&J1,J2-Ground: 1380VDC/1min. J3, J4, USB/LAN/ Ground: 707VDC/1min; |
| 3. Insulation resistance | | --- | More than 100Mohm at 25°C, 70%RH. |
| 4. Conducted emission | | --- | IEC/EN61326-1 Industrial Location - B, FCC part 15-B, VCCI-B |
| 5. Radiated emission | | --- | IEC/EN61326-1 Industrial Location - A, FCC part 15-A, VCCI-A |

| MECHANICAL | | | |
|-----------------------|----------|-----|---|
| 1. Cooling | | --- | Forced air cooling by internal fan |
| 2. Weight | STANDARD | Kg | Less than 1.9Kg. |
| | | | Less than 2.4Kg. |
| 3. Dimensions (WxHxD) | STANDARD | mm | H: 83, W: 70, D: 350 (excluding bus bars, handles...). (Refer to Outline drawing) |

NOTES:

- *1: Minimum voltage is guaranteed to maximum 0.1% of rated output voltage.
- *2: Minimum current is guaranteed to maximum 0.2% of rated output current.
- *3: For cases where conformance to various safety standards (UL, IEC, etc...) is required, to be described as 100-240Vac (50/60Hz).
- *4: $T_a=25^{\circ}\text{C}$ with rated output power.
- *5: Not including EMI filter inrush current, less than 0.2mSec.
- *6: At 85~132Vac or 170~265VAC, constant load.
- *7: From No-Load to Full-Load, constant input voltage. Measured at the sensing point in Remote Sense.
- *8: Measured with JEITA RC-9131A (1:1) probe.
- *9: From 10% to 90% or 90% to 10% of Rated Output Voltage, with rated resistive load.
- *10: From 90% to 10% of Rated Output Voltage.
- *11: For load voltage change, equal to the unit voltage rating, constant input voltage.
- *13: The Constant Current programming, readback and monitoring accuracy do not include the warm-up and Load regulation thermal drift.
- *14: Measured with JEITA RC-9131A (1:1) probe.
- *15: For cases where the time interval between each down programming is longer than T_d (time delay).
- *16: For cases where the time interval between each down programming is shorter than T_d (Time delay).
- *17: T_d typical Minimum time between consecutive down programming cycles.
- *18: PS with LAN, models decrease efficiency by 0.25% and increase input current by 0.25%.
PS with Isolated analog option decreases efficiency by 0.75% and increases input current by 0.75%.
- *19: At rated output power.
- *21: For Parallel operation more than 2 units 5% of total output current is required.

2.3 RMX-4104 Series Specifications

| MODEL | | RMX-4104 | | | | |
|--|--|---|-------|-------|-------|-------|
| | | N/A | 20-40 | 36-24 | 60-14 | 100-8 |
| 1. Rated output voltage(*1) | V | | 20 | 36 | 60 | 100 |
| | Vin ≥ 100Vac, Ta ≤ 50°C | A | 40 | 24 | 14 | 8 |
| 2. Rated output current (*2)(*21) | 85Vac ≤ Vin < 100Vac, Ta ≤ 40°C | A | 40 | 24 | 14 | 8 |
| | 85Vac ≤ Vin < 100Vac, 40°C < Ta ≤ 50°C | A | 36 | 20 | 12.5 | 7.5 |
| | Vin ≥ 100Vac, Ta ≤ 50°C | W | 800 | 864 | 840 | 800 |
| 3. Rated output power | 85Vac ≤ Vin < 100Vac, Ta ≤ 40°C | W | 800 | 864 | 840 | 800 |
| | 85Vac ≤ Vin < 100Vac, 40°C < Ta ≤ 50°C | W | 720 | 720 | 750 | 750 |
| | | | | | | |
| CONSTANT VOLTAGE MODE | | | 20-40 | 36-24 | 60-14 | 100-8 |
| 1. Max. Line regulation (*6) | --- | 0.01% of rated output voltage+2mV | | | | |
| 2. Max. Load regulation (*7) | --- | 0.01% of rated output voltage+2mV | | | | |
| 3. Ripple and noise (p-p, 20MHz) (*8) | mV | | 50 | 50 | 60 | 80 |
| 4. Ripple r.m.s. 5Hz~1MHz | mV | | 5 | 5 | 12 | 15 |
| 5. Temperature coefficient | PPM/°C | 30PPM/°C from rated output voltage, following 30 minutes warm-up. | | | | |
| 6. Temperature stability | --- | 0.05% of rated Vout over 8hrs. interval following 30 minutes warm-up. Constant line, load & temp. | | | | |
| 7. Warm-up drift | --- | Less than 0.05% of rated output voltage+2mV over 30 minutes following power on. | | | | |
| 8. Remote sense compensation/wire | V | | 1 | 2 | 3 | 5 |
| 9. Up-prog. Response time, 0~Vomax>(*9) | mS | | 50 | 50 | 50 | 100 |
| 10. Down-prog. response time: Full load (*9) | Time delay (*17) | mS | 25 | 25 | 25 | 80 |
| | No load (*10) (*15) (*17) | | 425 | 450 | 570 | 1370 |
| | No load (*10) (*16) (*17) | | 110 | 155 | 175 | 375 |
| | No load (*10) (*16) (*17) | | 470 | 470 | 500 | 1200 |
| 11. Transient response time | mS | Time for output voltage to recover within 0.5% of its rated output for a load change 10~90% of rated output current. Output set-point: 10~100%, Local sense. Less than 1mS, for models up to and including 100V | | | | |
| 12. Hold-up time (*18) | --- | 10mSec Typical. Rated output power. | | | | |
| CONSTANT CURRENT MODE | | | 20-40 | 36-24 | 60-14 | 100-8 |
| 1. Max. Line regulation (*6) | --- | 0.01% of rated output current+2mA | | | | |
| 2. Max. Load regulation (*11) | --- | 0.01% of rated output current+5mA | | | | |
| 3. Load regulation thermal drift | --- | For 10V: Less than 0.15% of rated output current over 30 minutes following load change. For 20V ~ 100V: Less than 0.1% of rated output current over 30 minutes following load change. | | | | |
| 4. Ripple r.m.s. 5Hz~1MHz | mA | | 100 | 31 | 28 | 12 |
| 5. Temperature coefficient | PPM/°C | 100PPM/°C from rated output current, following 30 minutes warm-up. | | | | |
| 6. Temperature stability | --- | 0.05% of rated Iout over 8hrs. interval following 30 minutes warm-up. Constant line, load & temperature. | | | | |
| 7. Warm-up drift | --- | 10V model: Less than +/-0.3%, 20V model: Less than +/-0.15%, 36V~100 models: Less than +/-0.1% of rated output current over 30 minutes following power on. | | | | |
| PROTECTIVE FUNCTIONS | | | 20-40 | 36-24 | 60-14 | 100-8 |
| 1. Foldback protection | --- | Output shut-down when power supply change mode from CV to CC or CC to CV. User presetable. Reset by AC input recycle in autostart mode or by OUTPUT button or by rear panel ENABLE, or by communication port. | | | | |
| 2. Over-voltage protection (OVP) | --- | Inverter Shut down method. Reset by AC input recycle in autostart mode or by OUTPUT button or by rear panel ENABLE, or by communication port. | | | | |
| 3. Over - voltage trip point | V | | 1~24 | 2~40 | 5~66 | 5~110 |
| 4. Output under voltage limit (UVL) | --- | Preset by front panel or communication port. Prevents from adjusting Vout below limit. Does not affect in analog programming. | | | | |
| 5. Output under voltage protection (UVP) | --- | Output shut-down when power supply output voltage goes below UVP programming. User presetable. Reset by AC input recycle in autostart mode or by OUTPUT button or by rear panel ENABLE, or by communication port. | | | | |
| 6. Over temperature protection | --- | User Selectable. Latched or non latched | | | | |

| ANALOG PROGRAMMING AND MONITORING | | |
|------------------------------------|-----|--|
| 1. Vout voltage programming | --- | 0~100%, 0~5V or 0~10V, user selectable. Accuracy and linearity: +/-0.5% of rated Vout. |
| 2. Iout voltage programming (*13) | --- | 0~100%, 0~5V or 0~10V, user selectable. Accuracy and linearity: +/-1% of rated Iout. |
| 3. Vout resistor programming | --- | 0~100%, 0~5/10Kohm full scale, user selectable. Accuracy and linearity: +/-1% of rated Vout. |
| 4. Iout resistor programming (*13) | --- | 0~100%, 0~5/10Kohm full scale, user selectable. Accuracy and linearity: +/-1.5% of rated Iout. |
| 5. Shut Off (SO) control | --- | By electrical Voltage: 0~0.6V/4~15V or dry contact, user selectable logic. |
| 6. Output current monitor (*13) | --- | 0~5V or 0~10V, user selectable. Accuracy: +/-1%. |
| 7. Output voltage monitor | --- | 0~5V or 0~10V, user selectable. Accuracy: +/-1%. |
| 8. Power supply OK signal | --- | 4~5V-OK, 0V-Fail. 500ohm series resistance. |
| 9. Parallel operation (*20) | --- | Possible, up to 6 units in master/slave mode with single wire current balance connection. |
| 10. Series operation | --- | 2 identical units (with external diodes). |
| 11. CV/CC indicator | --- | Open collector. CC mode: On, CV mode: Off. Maximum voltage: 30V, maximum sink current: 10mA |
| 12. Interlock (ILC) control | --- | Enables/Disables the PS output by dry contact (Short: On, Open: Off, Source current: less than 0.5mA). Ena/Dis is activated by front panel. |
| 13. Local/Remote mode Control | --- | By electrical signal or Open/Short: 0~0.6V or short: Remote, 2~15V or open: Local |
| 14. Local/Remote mode Indicator | --- | Open collector (shunted by 36V zener). On (0~0.6V, 10mA sink current max.)-Remote. Off-Local (30V max.). |
| 15. Trigger out | --- | Maximum low level output =0.8V, Minimum high level output =3.8V, Maximum high level output =5V, Maximum source current =16mA, pulse =20µs Typical. |
| 16. Trigger in | --- | Maximum low level input =1.2V, Minimum high level input =3.5V, Maximum high level input =5V, Maximum sink current =16mA, positive edge, trigger: tw =10µs minimum, Tr/Tf =1µs maximum. |
| 17. Programmed signal 1 | --- | Open collector, maximum voltage 25V, maximum sink current 100mA. (Shunted by 27V zener) |
| 18. Programmed signal 2 | --- | Open collector, maximum voltage 25V, maximum sink current 100mA. (Shunted by 27V zener) |

| FRONT PANEL | | |
|----------------------|-----|---|
| 1. Control functions | --- | Multiple options with 2 Encoders |
| | --- | Vout/Iout manual adjust |
| | --- | OVP/UVL /UVP manual adjust |
| | --- | Protection Functions - OVP, UVL, UVP, Foldback, OCP, INT, SO |
| | --- | Communication Functions - Selection of LAN,RS232,RS485,USB |
| | --- | Communication Functions - Selection of Baud Rate, Address |
| | --- | Analog Control Functions - Selection Voltage/resistive programming, 5V/10V, 5K/10K programming |
| | --- | Analog Control Functions - Selection of Voltage/Current Monitoring 5V/10V, Output ON/OFF, Front Panel Lock. |
| 2. Display | --- | Vout: 4 digits, accuracy: 0.5% of rated output voltage +/-1 count. |
| | --- | Iout: 4 digits, accuracy: 0.5% of rated output current +/-1 count. |
| 3. Indications | --- | GREEN LEDs: FINE, MENU, PREV, PROT, REM, OUTPUT, CV, CC |
| | --- | RED LED: PROT (OVP, UVP, OTP, FOLD, AC FAIL). |
| 4. Function buttons | --- | FINE, MENU, PREV, PROT, REM, OUTPUT |

| PROGRAMMING AND READBACK (RS232/485,USB, LAN) | | |
|---|-----|--|
| 1. Vout programming accuracy | --- | 0.05% of rated output voltage |
| 2. Iout programming accuracy (*13) | --- | 0.1% of actual +0.1% of rated output current |
| 3. Vout programming resolution | --- | 0.012% of full scale |
| 4. Iout programming resolution | --- | 0.012% of full scale |
| 5. Vout readback accuracy | --- | 0.05% of rated output voltage |
| 6. Iout readback accuracy (*13) | --- | 0.1% of actual +0.3% of rated output current |
| 7. Vout readback resolution | --- | 0.012% of full scale |
| 8. Iout readback resolution | --- | 0.012% of full scale |

2.3 RMX-4104 Series Specifications

| | | RMX-4104 | | | | |
|--|-----|---|-----------|------------|------------|----------|
| INPUT CHARACTERISTICS | | | 20-40 | 36-24 | 60-14 | 100-8 |
| 1. Input voltage/freq. (*3) | --- | 85~265Vac continuous, 47~63Hz, single phase | | | | |
| 2. Maximum Input current 100/200VAC (*4) | --- | | 9.65/4.75 | 10.30/5.10 | 10.00/4.95 | 9.50/4.7 |
| 3. Power Factor (Typ) | --- | 0.99 at 100Vac, 100% load / 0.98 at 200Vac, 100% load | | | | |
| 4. Efficiency (Typ) 100/200VAC (*4) | % | | 84/86 | 85/87 | 85/87 | 85/87 |
| 5. Inrush current (*5) | --- | Less than 30A | | | | |

| ENVIRONMENTAL CONDITIONS | | | | | | |
|--|-----|--|-------|-------|-------|-------|
| 1. Operating temperature | --- | 0~50°C, 100% load. | | | | |
| 2. Storage temperature | --- | -20~85°C | | | | |
| 3. Operating humidity | % | 20~90% RH (no condensation). | | | | |
| 4. Storage humidity | % | 10~95% RH (no condensation). | | | | |
| 5. Altitude | --- | Maximum 3000m. From 2000m up to 3000m, max. Ambient temperature 40°C and rated output current according to the table below: | | | | |
| Rated output current at 100≤Vin≤265Vac | A | | 20-40 | 36-24 | 60-14 | 100-8 |
| Rated output current at 85≤Vin<100Vac | A | | 40 | 24 | 14 | 8 |
| | | | 36 | 20 | 12.5 | 7.5 |

| SAFETY/EMC | | | | | | |
|--------------------------|--------|-----|--|--|--|--|
| 1. Applicable standards: | Safety | --- | IEC61010-1, UL61010-1, CSA22.2 No.61010-1, EN61010-1. 10V≤Vout≤60V: Output,J1,J2,J3,J4,USB,LAN, are Non Hazardous Vout=100V:Output,J1,J2 are Hazardous J3,J4,USB,LAN are Non Hazardous | | | |
| | EMC | --- | IEC/EN61326-1 (Built to meet EN55022/EN55024) | | | |
| 2. Withstand voltage | | --- | 10≤Vout≤36V models: Input-Output&J1,J2,J3,J4,USB,LAN/ 4242VDC/1min; Input-Ground: 2828VDC/1min. Output&J1,J2,J3,J4,USB,LAN/Ground: 707VDC/1min. 60V,100V models: Input-Output&J1,J2: 4242VDC/1min; Input-J3,J4,USB,LAN/ 4242VDC/1min; Input-Ground: 2828VDC/1min. Output & J1,J2- J3,J4,USB,LAN/1910VDC/1min; Output&J1,J2-Ground: 1380VDC/1min. J3, J4, USB/LAN/ Ground: 707VDC/1min; | | | |
| 3. Insulation resistance | | --- | More than 100Mohm at 25°C, 70%RH. | | | |
| 4. Conducted emission | | --- | IEC/EN61326-1 Industrial Location - B, FCC part 15-B, VCCI-B | | | |
| 5. Radiated emission | | --- | IEC/EN61326-1 Industrial Location - A, FCC part 15-A, VCCI-A | | | |

| MECHANICAL | | | | | | |
|-----------------------|----------|-----|---|--|--|--|
| 1. Cooling | | --- | Forced air cooling by internal fan | | | |
| 2. Weight | STANDARD | Kg | Less than 2.1Kg. | | | |
| 3. Dimensions (WxHxD) | STANDARD | mm | H: 83, W: 70, D: 350 (excluding bus bars, handles...). (Refer to Outline drawing) | | | |

NOTES:

- *1: Minimum voltage is guaranteed to maximum 0.1% of rated output voltage.
- *2: Minimum current is guaranteed to maximum 0.2% of rated output current.
- *3: For cases where conformance to various safety standards (UL, IEC, etc...) is required, to be described as 100-240Vac (50/60Hz).
- *4: Ta=25°C with rated output power.
- *5: Not including EMI filter inrush current, less than 0.2mSec.
- *6: At 85~132Vac or 170~265VAC, constant load.
- *7: From No-Load to Full-Load, constant input voltage. Measured at the sensing point in Remote Sense.

- *8: Measured with JEITA RC-9131A (1:1) probe.
- *9: From 10% to 90% or 90% to 10% of Rated Output Voltage, with rated resistive load.
- *10: From 90% to 10% of Rated Output Voltage.
- *11: For load voltage change, equal to the unit voltage rating, constant input voltage.
- *13: The Constant Current programming, readback and monitoring accuracy do not include the warm-up and Load regulation thermal drift.
- *14: Measured with JEITA RC-9131A (1:1) probe.
- *15: For cases where the time interval between each down programming is longer than Td (time delay).
- *16: For cases where the time interval between each down programming is shorter than Td (Time delay).
- *17: Td typical Minimum time between consecutive down programming cycles.
- *18: At rated output power.
- *20: For Parallel operation more than 2 units 5% of total output current is required.
- *21: Refer to Fig.2-1 below

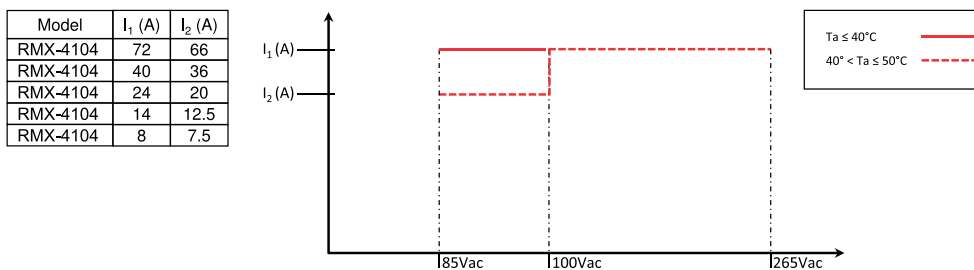
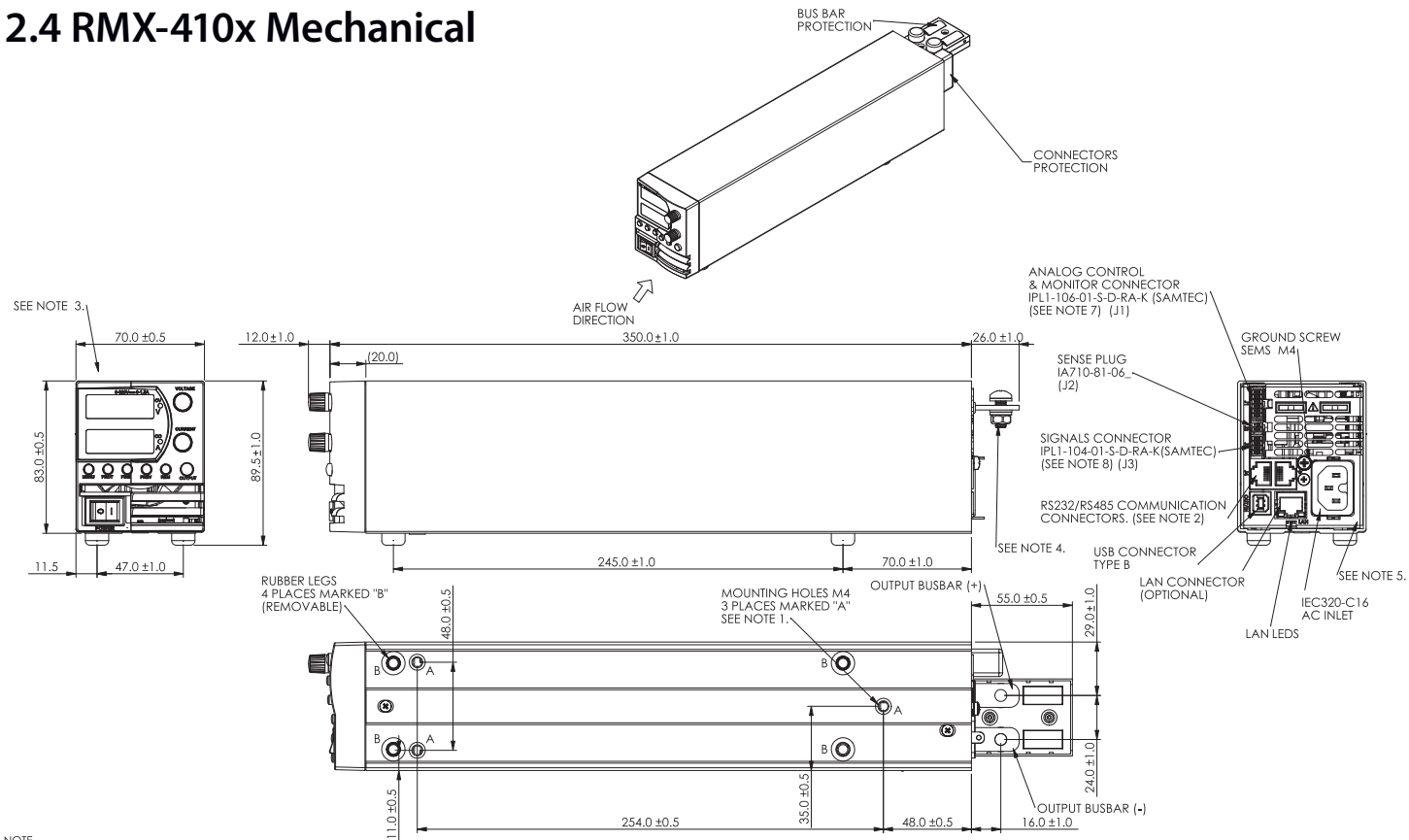

Fig. 2-1: RMX-4104 Rated Output Current Vs. Line Voltage and Ambient Temperature

2.4 RMX-410x Mechanical



- NOTE
1. MOUNTING SCREWS MUST NOT PROTRUDE INTO THE POWER SUPPLY MORE THAN 6.0 mm. TIGHTENING TORQUE MUST BE MAX. 0.58Nm
 2. RS232/RS485 COMMUNICATION RJ-45, SHIELDED, 8 CONTACTS CONNECTORS.
 3. MODEL NAME AND OUTPUT RATING SHOWN HERE ACCORDING TO THE SPECIFICATION.
 4. M6 OR 1/4" SCREWS FOR LOAD WIRES CONNECTION.
 5. RECEPTACLE SAMTEC P/N IPD1-06-D-K CONTACT PIN SAMTEC CC79R-2024-01-L HAND TOOL: CAT-HI-179-2024-11 WIRE AWG 20-24.
 6. RECEPTACLE SAMTEC P/N IPD1-04-D-K CONTACT PIN SAMTEC CC79R-2024-01-L HAND TOOL: CAT-HI-179-2024-11 WIRE AWG 20-24.

Fig.2-2

2.4.1 Rackmount Dimensions

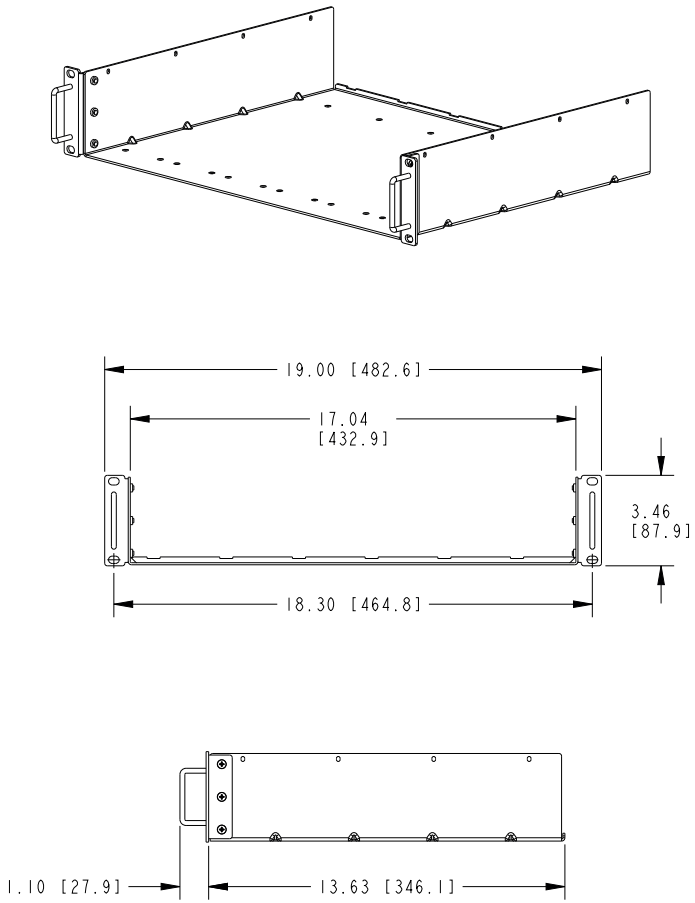

Fig.2-3: Dimensional drawing for the shelf in the RMX-410x Rackmount Kit (PN: 786186-01)

3.1 General

This chapter contains instructions for initial inspection, preparation for use and repackaging for shipment. Connection to PC, setting the communication port and linking RMX-410x power supplies are described in Chapter 7.

NOTE:

RMX-410x power supplies generate magnetic fields which might affect the operation of other instruments. If your equipment is susceptible to magnetic fields, do not position it adjacent to the power supply.

3.2 Preparation for Use

In order to be operational the power supply must be connected to an appropriate AC source. The AC source voltage should be within the power supply specification. Do not apply power before reading, Section 3.6 and 3.7.

Table 3-1 below, describes the basic setup procedure. Follow the instructions in Table 3-1 in the sequence given to prepare the power supply for use.

| Step no. | Item | Description | Reference |
|----------|-----------------|---|----------------------------|
| 1 | Inspection | Initial physical inspection of the power supply | Section 3.3 |
| 2 | Installation | Installing the power supply, Ensuring adequate ventilation. | Section 3.4 Section 3.5 |
| 3 | AC source | AC source requirements Connecting the power supply to the AC source. | Section 3.6 Section 3.7 |
| 4 | Test | Turn-on checkout procedure. | Section 3.8 |
| 5 | Load connection | Wire size selection. Local /Remote sensing. | Section 3.9 |
| 6 | Default setting | Single or multiple loads. | Section 7.2.1 |

Table 3-1: Basic setup procedure

3.3 Initial Inspection

Prior to shipment this power supply was inspected and found free of mechanical or electrical defects. Upon unpacking of the power supply, inspect for any damage which may have occurred in transit. The inspection should confirm that there is no exterior damage to the power supply such as broken knobs or connectors and that the front panel and meter faces are not scratched or cracked. Keep all packing material until the inspection has been completed. If damage is detected, file a claim with carrier immediately and notify the NI sales or service facility nearest you.

3.4 Rackmount

The RMX-410x power supply series is designed to fit in a standard 19" 2U height rack. Six units (70mm width) can be assembled into 19" 2U-rack. Refer to Fig.3-1.



Fig. 3-1

3.5 Location, Mounting and Cooling

This power supply is fan cooled. The air intake is at the front panel and the exhaust is at the rear panel. Upon installation allow cooling air to reach the front panel ventilation inlets. Allow minimum 10 cm (4") of unrestricted air space at the front and the rear of the unit.

The power supply should be used in an area that the ambient temperature does not exceed +50°C.

3.5.1 Rackmount Installation

Complete the following instructions to install the rear support bracket for mounting the RMX-410x programmable power supply in an NI equipment rack. (The rackmount shelf and support brackets are in shipping kit PN 786186-01.)

1. In the desired rack location, screw the support brackets to the rack internal rails as shown in Fig. 3-2. The kit includes four #10-32 UNF screws of 12.7 mm (0.5") length.

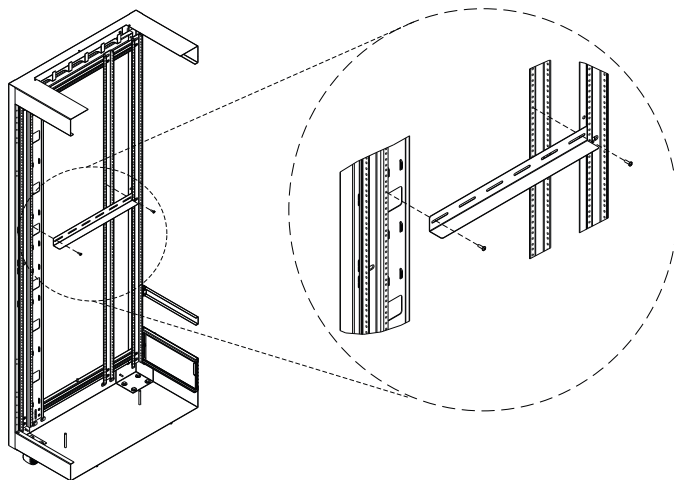

Fig. 3-2: Install the support brackets to the side of the rack to provide rear support for the rackmount shelf

2. Screw the power supplies to the rackmount shelf as shown in Fig. 3-3.

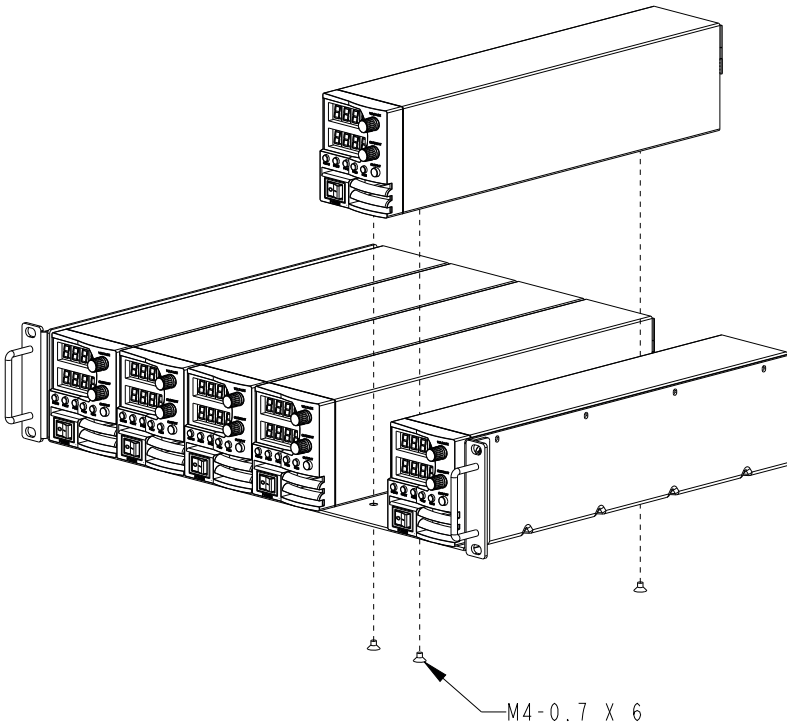

Fig. 3-3: Attach the power supplies to the rackmount shelf

WARNINGS:

Mounting the power supplies into the rack requires at least two people to support the chassis during installation.

To prevent injury when mounting or servicing the chassis in a rack, you must take precautions to ensure the system remains stable.

3. Place the rackmount shelf with the power supplies on the brackets. Screw the rackmount shelf to the front rails.

3.6 AC Source Requirements

The RMX-410x series can be operated from a nominal 100V to 240V, single phase, 47~63Hz. The input voltage range and current required for each model is specified in Chapter 2. Ensure that under heavy load, the AC voltage supplied to the power supply does not fall below the specifications described in Chapter 2.

3.7 AC Input Power Connection

WARNING:

Some components inside the power supply are at AC voltage even when the On/Off switch is in the "Off" position. To avoid electric shock hazard, disconnect the line cord and load and wait two minutes before removing cover.

3.7.1 AC Input Connector

An IEC connector is provided on the rear panel for connecting the unit to the AC power source with an AC cord. The IEC connector also provides the safety ground connection while the AC cord is plugged into an appropriate AC.

3.7.2 AC Input Cord

Refer to section 1.3.4 for details of the AC input cords recommended.

WARNING:

The AC input cord connector is the disconnect device of the power supply. The connector must be readily identifiable and accessible to the user. The AC input cord must be no longer than 3m.

3.8 Turn-On Checkout Procedure

3.8.1 General

The following procedure ensures that the power supply is operational and may be used as a basic incoming inspection check.

3.8.2 Prior to Operation

1. Ensure that the power supply is configured to the default setting:
AC On/Off switch at Off position.
Sense connector : Configured to Local Sense as shown in Fig.3-4:

- 1 Local (-) sense
- 2 (-) Sense
- 3 (+) Sense
- 4 Local (+) sense

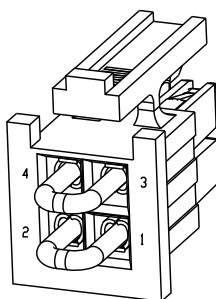

Plug P/N: IPD1-02-D-K
(SAMTEC)

Fig. 3-4: Sense connector default connection

2. Ensure that the protection of output bus-bars or of output connector is mounted and properly assembled for power supplies when the output voltage exceed 60VDC.
3. Connect the unit to an AC source as described in section 3.7.
4. Connect a DVM with appropriate cables for the rated voltage to the output terminals.
5. Turn the front panel AC power switch to On.
6. When power supply is turned ON the display shows "BBBB" and all LEDs illuminate momentarily. The power supply operating status is then displayed.

3.8.3 Constant Voltage Check

1. Turn on the output by pressing OUTPUT button so the OUTPUT LED illuminates.
2. Observe the power supply Voltage display and rotate the Voltage encoder. Ensure that the output voltage varies while the Voltage encoder is rotated. The minimum control range is from zero to the maximum rated output for the power supply model. Compare the DVM reading with the front panel Voltage display to verify the accuracy of the Voltage display. Ensure that the front panel CV LED illuminates.
3. Turn off the front panel AC power switch.

3.8.4 Constant Current Check

Ensure that the front panel AC power switch is at Off position and the DVM connected to the output terminals shows zero voltage.

1. Connect DC shunt across the output terminals. Ensure that the shunt and the wires current ratings are higher than the power supply rating. Connect a DVM to the shunt.
2. Turn the front panel AC power switch to On position.
3. Turn on the output by pressing OUTPUT button so the OUTPUT LED illuminates.
4. Observe the power supply Current display and rotate the Current encoder. Ensure that the output current varies while the Current encoder is rotated. The minimum control range is from zero to the maximum rated output for the power supply model. Compare the DVM reading with the front panel Current display to verify the accuracy of the Current display. Ensure that the front panel CC LED is on.
5. Turn off the front panel AC power switch.
6. Remove the shunt from the power supply output terminals.

3.8.5 OVP Check

Refer to Section 5.3.2 for explanation of the OVP function prior to performing the procedure below.

1. Turn the front panel AC power switch to On position and turn on the output by pressing OUTPUT button.
2. Using the Voltage encoder, adjust the output voltage to approx. 10% of the unit voltage rating.
3. Set OVP to 50% of the unit voltage rating.
4. Adjust the output voltage toward it's maximum and check that the output voltage cannot be increased more than the OVP setting.
5. Adjust OVP limit to the maximum.

3.8.6 UVL Check

The UVL can be set when the power supply output is Enabled (On) or Disabled (Off). UVL setting values are limited at the maximum level to approximately 5% below the Output Voltage setting. Attempting to adjust the value above this limit will result in no response to the adjustment attempt. The minimum value setting is zero.

1. Press PROT button. PROT (GREEN) LED illuminates. Current display shows "UUU" message.
2. Press Current Encoder. Voltage Display shows "UUU" message, Current display shows setting level.
3. Rotate the Voltage encoder to set "UUU".
4. Rotate the Current encoder to adjust the level.
5. Press PROT button twice or wait 15 sec. to return display to its previous state and then PROT LED turns OFF.
6. Adjust the output voltage toward it's minimum and check that the output voltage cannot be decreased below the UVL setting.
7. Adjust the UVL limit to the minimum.

3.8.7 Foldback Check

WARNING:

There is a potential shock hazard when checking a power supply with output voltage greater than 60VDC. Observe proper safety procedures during the checking.

Refer to Section 5.3.4 for explanation of the FOLD function prior to performing the procedure below.

1. Ensure that the output voltage is set to approx. 10% of the unit rating.
2. Adjust the Current encoder to set the current limit to approx. 10% of the unit rating.
3. Set Foldback to CC MODE.
4. Short the output terminals momentarily (approx. 0.5 sec.). Ensure that the output voltage falls to zero, the Voltage display shows "FOLD", Current display shows "FOLD" and the PROT red LED blinks.
5. Set Foldback to OFF. The output voltage remains zero.
6. Press OUTPUT button. Ensure that the output voltage returns to it's last setting.
7. Turn the output off by pressing OUTPUT button. Ensure that the Voltage display shows "OFF".

3.9 Connecting the Load

Turn off the AC input power before making or changing any rear panel connection. Ensure that all connections are securely tightened before applying power. There is a potential shock hazard when using a power supply with a rated output greater than 60VDC.

WARNING:

There is a potential shock hazard when using a power supply with an output voltage greater than 60VDC. Turn off the AC input power before making or changing any rear panel connection. Ensure that the protection of output bus-bars and output connectors is mounted and properly assembled when output voltage exceed 60VDC. Ensure that all connections are securely tightened before applying power.

3.9.1 Load Wiring

The following considerations should be made to select wiring for connecting the load to the power supply:

- **Current carrying capacity of the wire (refer to 3.9.2)**
- **Insulation rating of the wire should be at least equivalent to the maximum output voltage of the power supply.**
- **Maximum wire length and voltage drop (refer to 3.9.2)**
- **Noise and impedance effects of the load wiring (refer to 3.9.4).**

3.9.2 Current Carrying Capacity

Two factors must be considered when selecting the wire size:

1. Wires should be at least heavy enough not to overheat while carrying the power supply load current at the rated load, or the current that would flow in the event the load wires were shorted, whichever is greater.
2. Wire size should be selected to enable voltage drop per lead to be less than 1.0V at the rated current. Although units will compensate higher voltage drop in each load wire (refer to the specifications). It is recommended to minimize the voltage drop (1V maximum) to prevent excessive output power consumption from the power supply and poor dynamic response to load changes. Please refer to Tables 3-2 and 3-3 for maximum wire length to limit voltage drop in American and European dimensions respectively.



| Wire size AWG | Resistivity Ohm/1000ft | Maximum length in feet to limit voltage drop to 1V or less | | | | |
|------------------|---------------------------|---|-----|-----|-----|------|
| | | 5A | 10A | 20A | 50A | 80A |
| 14 | 2.526 | 80 | 40 | 20 | 8 | 5 |
| 12 | 1.589 | 120 | 60 | 30 | 12 | 7.5 |
| 10 | 0.9994 | 200 | 100 | 50 | 20 | 12.5 |
| 8 | 0.6285 | 320 | 160 | 80 | 32 | 20 |
| 6 | 0.3953 | 500 | 250 | 125 | 50 | 31 |
| 4 | 0.2486 | 800 | 400 | 200 | 80 | 50 |
| 2 | 0.1564 | 1200 | 600 | 300 | 125 | 78 |

Table 3-2: Maximum wire length for 1V drop on lead (in feet)

| Cross sect. area (mm ²) | Resistivity Ohm/Km | Maximum length in meters to limit voltage drop to 1V or less | | | | |
|---|-----------------------|---|------|------|------|------|
| | | 5A | 10A | 20A | 50A | 80A |
| 2.5 | 8.21 | 24.0 | 12 | 6 | 2.4 | 1.5 |
| 4 | 5.09 | 39.2 | 18.6 | 9.8 | 4 | 2.5 |
| 6 | 3.39 | 59.0 | 29.4 | 14.8 | 5.8 | 3.6 |
| 10 | 1.95 | 102.6 | 51.2 | 25.6 | 10.2 | 6.3 |
| 16 | 1.24 | 160.0 | 80 | 40 | 16 | 10 |
| 25 | 0.795 | 250.0 | 125 | 62 | 25.2 | 15.7 |
| 35 | 0.565 | 354.0 | 177 | 88 | 35.4 | 22 |

Table 3-3: Maximum wire length for 1V drop on lead (in meters)

For currents not shown in Table 3-2 and 3-3, use the formula:

$$\text{Maximum length} = 1000 / (\text{current} \times \text{resistivity})$$

Where current is expressed in amperes and resistivity in ohms/km or ohms/1000ft.

3.9.3 Wire Termination

The wires should be properly terminated with terminals securely attached. DO NOT use non terminated wires for load connection at the power supply.

CAUTION:

When local sensing, a short from +LS or +S to -V or -S or -LS, will cause damage to the power supply. Reversing the sense wires might cause damage to the power supply in local and remote sensing. (Do not connect -S to +V or +S to -V.)

3.9.4 Noise and Impedance Effects

To minimize the noise pickup or radiation, the load wires and remote sense wires should be twisted pairs to the shortest possible length. Shielding of sense leads may be necessary in high noise environments. Where shielding is used, connect the shield to the chassis via a rear panel Ground screw. Even if noise is not a concern, the load and remote sense wires should be twisted-pairs to reduce coupling, which might impact the stability of power supply. The sense leads should be separated from the power leads.

Twisting the load wires reduces the parasitic inductance of the cable which could produce high frequency voltage spikes at the load and the output of power supply, because of current variation in the load itself.

The impedance introduced between the power supply output and the load could make the ripple and noise at the load worse than the noise at the power supply rear panel output. Additional filtering with bypass capacitors at the load terminals may be required to bypass the high frequency load current.

3.9.5 Inductive Loads

Inductive loads can produce voltage spikes that may be harmful to the power supply. A diode should be connected across the output. The diode voltage and current rating should be greater than the power supply maximum output voltage and current rating. Connect the cathode to the positive output and the anode to the negative output of the power supply.

Where positive load transients such as back EMF from a motor may occur, connect a surge suppressor across the output to protect the power supply. The breakdown voltage rating of the suppressor must be approximately 10% higher than the maximum output voltage of the power supply.

3.9.6 Making the Load Connections

WARNING:

There is a potential shock hazard when using a power supply with an output voltage greater than 60VDC. To protect personnel against accidental contact with hazardous voltages, ensure that the protection of output bus-bars and output connectors is mounted and properly assembled. Ensure that the load and its connections have no accessible live parts. Ensure that the load wiring insulation rating is greater than or equal to the maximum output voltage of the power supply.

CAUTION:

Ensure that the load wiring mounting hardware does not short the output terminals. Heavy connecting cables must have some form of strain relief to prevent loosening the connections or bending the bus-bars.

20V to 100V Models

Refer to Fig.3-5 for connection of the load wires to the power supply bus-bars and to Fig.3-6 for mounting the bus-bars shield to the chassis.

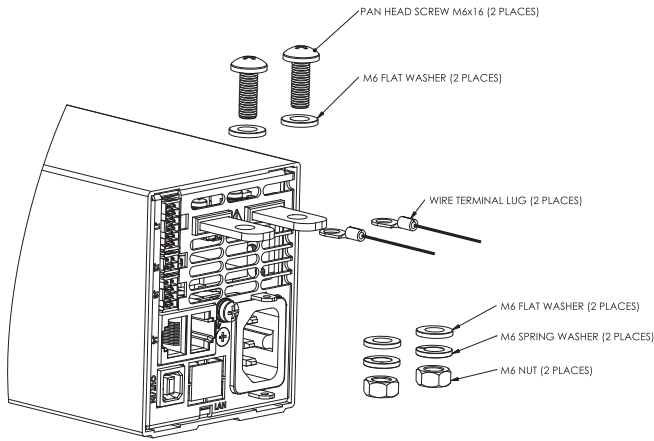

Fig. 3-5: Load wires connection, 20V to 100V models.

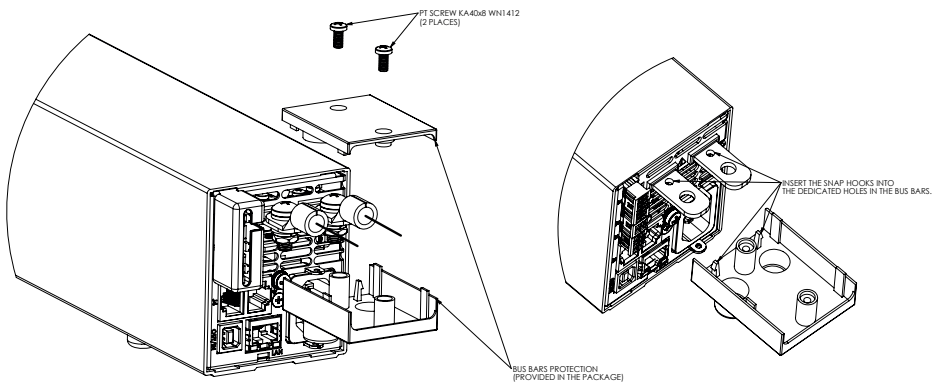

Fig. 3-6: Bus-bars shield mounting

60V, 100V Models

WARNING:

There is a potential shock hazard when using a power supply with an output voltage greater than 60VDC. Do not turn ON power supply when output voltage is above 60VDC without output bus-bars and output connectors protection assembled.

Ensure that the protection of output bus-bars and output connectors is mounted and properly assembled, and that the bus bar protection is locked by two PT type screws as described in Fig. 3.6.

3.9.7 Connecting Single Loads, Local Sensing (default)

Fig.3-7 shows recommended load and sensing connections for a single load. The local sense lines shown are default connections at the rear panel J2 sense connector. Local sensing is suitable for applications where load regulation is less critical.

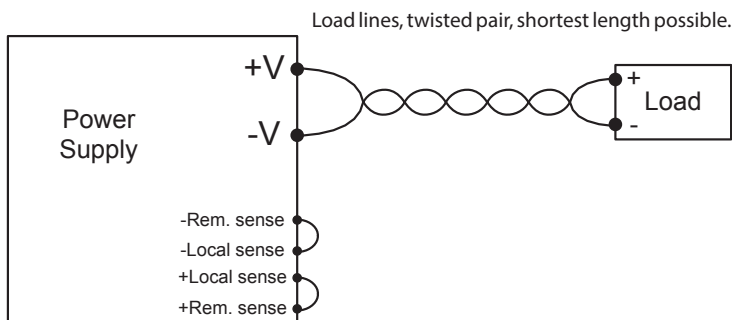

Fig.3-7: Single load connection, local sensing

3.9.8 Connecting Single Loads, Remote Sensing

Fig.3-8 shows recommended remote sensing connection for single loads. Remote sensing is used when, in Constant Voltage mode, the load regulation is important at the load terminals. Use twisted or shielded wires to minimize noise pick-up. If shielded wires are used, the shield should be connected to the ground at one point, either at the power supply chassis or the load ground. The optimal point for the shield ground should be determined by experimentation.

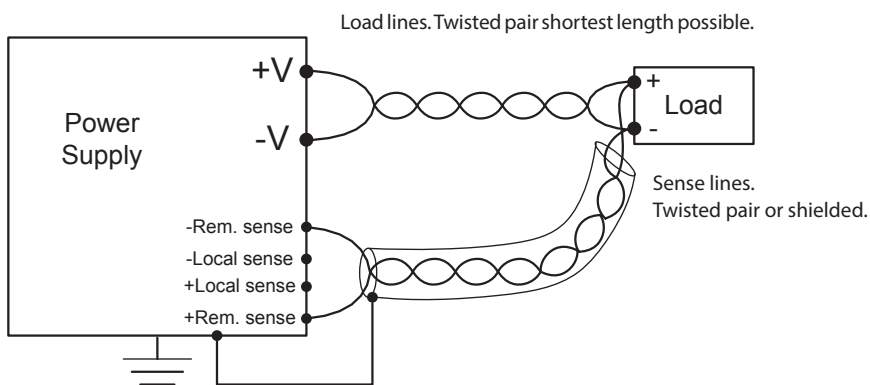

Fig.3-8: Remote sensing, single load

3.9.9 Connecting Multiple Loads, Radial Distribution Method

Fig.3-9 shows multiple loads connected to one supply. Each load should be connected to the power supply's output terminals using separate pairs of wires. It is recommended that each pair of wires will be as short as possible and twisted or shielded to minimize noise pick-up and radiation. The sense wires should be connected to the power supply output terminals or to the load with the most critical load regulation requirement.

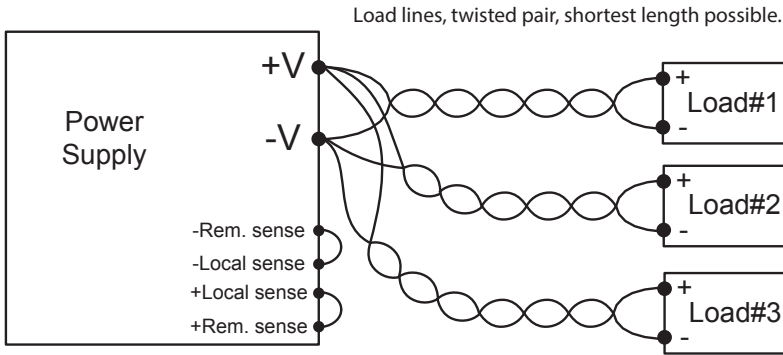

Fig.3-9: Multiple loads connection, radial distribution, local sense

3.9.10 Multiple Load Connection with Distribution Terminals

If remotely located output distribution terminals are used, the power supply output terminals should be connected to the distribution terminals by a pair of twisted and/or shielded wires. Each load should be separately connected to the remote distribution terminals (see Fig.3-10).

If remote sensing is required, the sensing wires should be connected to the distribution terminals or at the most critical load.

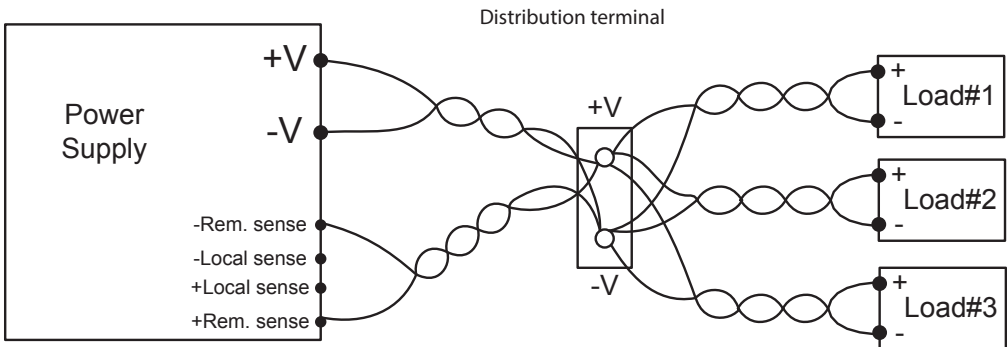

Fig.3-10: Multiple loads connection with distribution terminal

3.9.11 Grounding Outputs

Either the positive or negative output terminals can be grounded. To avoid noise problems caused by common-mode current flowing from the load to ground, it is recommended to ground the output terminal as close as possible to the power supply chassis ground.

Always use two wires to connect the load to the power supply regardless of how the system is grounded.

WARNING:

The power supplies shall not float outputs more than +/- 100VDC above/below chassis ground.

3.10 Local and Remote Sensing

The rear panel J2 sense connector is used to configure the power supply for local or remote sensing of the output voltage. Refer to Fig.3-10 for sense connector location.

3.10.1 Sense Wiring

WARNING:

There is a potential shock hazard at the sense connector when using a power supply with an output voltage greater than 60VDC. Local sense and remote sense wires should have a minimum insulation rating equivalent or greater than the maximum output voltage of the power supply. Ensure that the connections at the load end are shielded to prevent accidental contact with hazardous voltages.

3.10.2 Local Sensing

The power supply is shipped with the rear panel J2 sense connector wired for local sensing of the output voltage. Refer to Table 3-4 for J2 terminals assignment. With local sensing, the output voltage regulation is made at the output terminals. This method does not compensate for voltage drop on the load wires, therefore it is recommended only for low load current applications or where the load regulation is less critical.

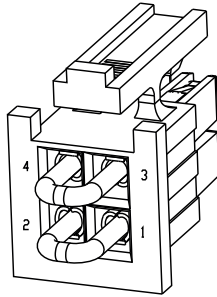

Fig.3-11: Sense connector location

| Terminal | Function |
|----------|---|
| J2-1 | Local negative sense. Connected internally to the negative output terminal (-LS). |
| J2-2 | Remote negative sense (-S). |
| J2-3 | Remote positive sense (+S). |
| J2-4 | Local positive sense. Connected internally to the positive output terminal (+LS). |

Table 3-4: J2 terminals

3.10.3 Remote Sensing

WARNING:

There is a potential shock hazard at the sense point when using power supply with an output voltage greater than 60VDC. Ensure that the connections at the load end are shielded to prevent accidental contact with hazardous voltages.

WARNING:

Do not operate the Power Supply with remote sense wire connected to the load without connecting load wire to the output terminal. Make sure that the connection is reliable to avoid disconnection during operation. Disconnection may cause damage to the power supply.

CAUTION:

When using shielded sense wires, ground the shield in one place only. The location can be the power supply chassis or one of the output terminals.

Use remote sense where the load regulation at the load end is critical. In remote sense, the power supply will compensate for voltage drop on the load wires. Refer to the specifications for the maximum voltage drop on load wires. The voltage drop is subtracted from the total voltage available at the output. Follow the instructions below to configure the power supply for remote sensing:

1. Ensure that the AC On/Off is in the Off position.
2. Remove the local sense jumpers from J2.
3. Connect the negative sense lead to terminal J2-2 (-S) and the positive sense lead to terminal J2-3(+S) of the J2 mating connector. Ensure that the J2 mating connector is plugged securely into the rear panel sense connector, J2.
4. Turn On the power supply.

NOTES:

1. If the power supply is operating in remote sense and either the positive or negative load wire is not connected, an internal protection circuit will activate and shut down the power supply. To resume operation, turn the AC On/Off to the Off position, connect the open load wire, and turn On the power supply.
2. If the power supply is operated without the remote sense lines or local sense jumpers, it will continue to work, but the output voltage regulation will be degraded. Also, the OVP circuit may activate and shut down the power supply.

3.10.4 J2 Sense Connector Technical Information

- J2 connector type: IPL1-102-01-S-D-RA-K, SAMTEC.
- Plug type: IPD1-02-D-K, SAMTEC.
- Contact pins: CC79R-2024-01-L, SAMTEC.
- Hand tool: CAT-HT-179-2024-11, SAMTEC
- Wire AWG: 24 up to 20

3.11 Repackaging for Shipment

To ensure safe transportation of the instrument, contact the NI sales or service facility near you for Return Authorization and shipping information. Refer to Warranty Information for further instructions.

4.1 Introduction

The RMX-410x Power Supply series has a full set of controls, indicators and connectors that allow the user to set up and operate the unit. Before starting to operate the unit, please read the following sections for an explanation of the functions, controls and connector terminals.

- Section 4.2: Front Panel Display and Controls.
- Section 4.3: Rear Panel Controls and Connectors.

4.2 Front Panel Display and Controls

Refer to Fig4-1 and Table 4-1 for description of the Front Panel controls and indicators.

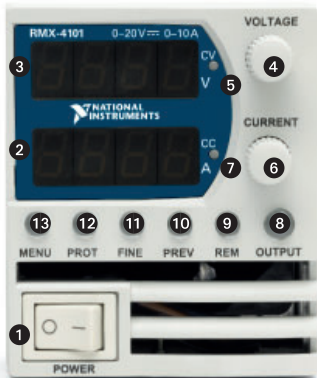

Fig. 4-1: Front panel controls and indicators

| No. | Control/Indicator | Description | Section |
|-----|---------------------------------|---|----------------|
| 1 | AC Power Switch | AC ON/OFF control | |
| 2 | Current display | 4 digit 7-segment LED display. Normally displays the output current. In preview mode, the display indicates the program setting of output current. | |
| 3 | Voltage Display | 4 digit 7-segment LED display. Normally displays the output voltage. In preview mode, the display indicates the program setting of output voltage. | |
| 4 | Voltage encoder and button | Encoder : high resolution rotary Encoder for adjusting the output voltage. Button: Auxiliary function to select between menu levels. | 5.2.1 |
| 5 | Constant Voltage mode indicator | Green LED, light for Constant-Voltage mode operation. | |
| 6 | Current encoder and button | Encoder: High resolution rotary Encoder for adjusting the output current. Button: Auxiliary function to select between menu levels. | 5.2.2 |
| 7 | Constant Current mode indicator | Green LED, light for Constant-Current mode operation. | |
| 8 | OUTPUT button/indicator | Main function: output ON/OFF control. Press OUTPUT to set the output ON or OFF. Press to recovery after OVP, UVP or FOLD fails. Green LED, lights when the DC Output is enabled. Auxiliary function: Select between Safe Start and Auto Start modes. | 5.2.4 5.2.5 |
| 9 | REM button/indicator | Main function: Go to local. Press REM to put the unit into local. REM button is disabled at Local Lockout mode. Green LED, lights when the unit is in communication Remote mode. Auxiliary function: Communication menu. | |
| 10 | PREV button/indicator | Main function: Press PREV to display the output voltage and current limit setting. For 5 sec. the display will show the setting and then it will return to show the actual output voltage and current. Green LED, lights when PREV button is pressed. Auxiliary function: Front Panel Lock. Press and hold PREV button to toggle between "Locked front panel" and "Unlocked front panel". The display will cycle between LFP and UFP . Releasing the PREV button while one of the modes is displayed, selects that mode. | |
| 11 | FINE button/indicator | Voltage, Current, Delay and Counter Fine/Coarse adjustment control. Operates as a toggle switch. In Fine mode, the VOLTAGE and Current encoders operate with high resolution and in Coarse mode with lower resolution (approx. 6 turns). Green LED, lights when the unit is in Fine mode. | |
| 12 | PROT button/ Alarm indicator | Main function: Red LED blinks in cases of fault detection: OVP, UVP, OTP, Foldback, Interlock and AC fail. Auxiliary function: Protection menu. Green LED illuminates when the unit is in protection menu mode. | 5.3 |
| 13 | Main Menu button/ indicator | Used for selection between analog or digital mode control, rear panel control parameters, memory management, trigger and program setting, parallel mode settings and software version. | |

Table 4-1: Front panel controls and indicators

4.3 Rear Panel Connectors

Refer to Fig.4-2 and Table 4-2 for description of the Rear Panel connectors.

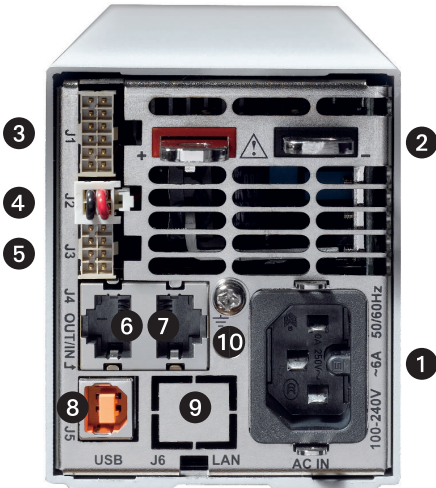

Fig. 4-2: Rear panel connections

| No. | Connection | Description | Section |
|-----|---------------------------------|--|---------|
| 1 | AC Input Connector | IEC320-16 TYPE CONNECTOR | |
| 2 | DC output bus-bar | Bus-bars for 10V to 100V models. Use M6 or 1/4" screws. | 3.9 |
| 3 | Analog Control and signals. J1 | Connector for remote analog interface. Analog control and monitoring. Referenced internally to output potential -S. | 4.3.1 |
| 4 | Local/Remote sense connector J2 | Connector for making remote sensing connections to the load for regulation of the load voltage and compensation of load wire drop. | 3.10 |
| 5 | Isolated control and signal. J3 | Control and monitoring signal, isolated from the output potential. | 4.3.2 |
| 6 | Remote Serial Out connector | RJ-45 type connector, used for chaining power supplies to/from a serial communication bus. | 7.3 |
| 7 | Remote Serial In connector | RJ-45 type connector, use for connecting power supplies to RS232 or RS485 port of computer for remote control purposes. When using several power supplies in a power system, the first unit Remote-In is connected to the computer and the remaining units are chained, Remote-In to Remote-Out. | 7.3 |
| 8 | USB Connector | USB interface connector, type B | |
| 9 | LAN Connector | LAN interface connector, type RJ-45 | |
| 10 | Ground screw | M4X8 for chassis Ground connection | |

Table 4-2: Rear panels connections

WARNING:

Terminals 7, 9 and 12 of J1 are connected internally to the negative sense(-S) potential of the power supply. Do not attempt to bias any of these terminals relative to the negative sense. Use the Isolated Programming interface option to allow control from a programming source at a different potential relative to the power supply negative.

CAUTION:

To prevent ground loops and to maintain the isolation of the power supply when programming from J1, use an ungrounded programming source.

WARNING:

There is a potential shock hazard at the output when using a power supply with output greater than 60VDC. Use wires with minimum insulation rating equivalent to the maximum output voltage of the power supply.

4.3.1 J1 Connector Terminal and Function

Control and monitoring signals are referenced to the negative sense potential (-S).

Connector Technical Information:

- Connector type: IPL1-106-01-S-D-RA-K, SAMTEC
- Receptacle type: IPD1-06-D-K, SAMTEC
- Contact pins: CC79R-2024-01-L, SAMTEC
- Hand tool: CAT-HT-179-2024-11, SAMTEC
- Wire: AWG 20-24

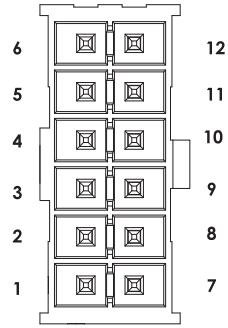

Fig.4-3: J1 connector terminals and functions

| Pin | Parameter | Specification | Section |
|-----|----------------|---|----------|
| 1 | LOC/REM SELECT | Input for selecting between Local or Remote analog programming of output voltage and output current. | 6.2 |
| 2 | P | Output for current balance in parallel operation | 5.5 |
| 3 | I_MON | Monitoring power supply output current | 6.6 |
| 4 | LOC/REM MON | Output for indicating if the unit is in Local or Remote analog programming mode. | |
| 5 | IPGM | Input for remote analog voltage/resistance programming of the Output Current. | 6.4, 6.5 |
| 6 | VPGM | Input for remote analog voltage/resistance programming of the Output Voltage. | 6.4, 6.5 |
| 7 | COM | Control Common. Return for VMON, IMON, CV/CC, LOC/REM. Connected internally to the negative sense potential (-S). | |
| 8 | CV/CC | Output for Constant-Voltage / Constant-Current mode indication. | 5.8.1 |
| 9 | COM | Control Common. Return for VMON, IMON, CV/CC, LOC/REM. Connected internally to the negative sense potential (-S). | |
| 10 | V_MON | Output for monitoring the power supply Output Voltage. | 6.6 |
| 11 | IPGM_RTN | Return for IPGM input. | |
| 12 | VPGM_RTN | Return for VPGM input. Connected internally to the "-S". | |

Table 4-3: J1 connector terminals and functions

4.3.2 J3 Connector Terminal and Function

Control and monitoring signals are isolated from the power supply output.

Connector Technical Information

- Connector type: IPL1-104-01-S-D-RA-K, SAMTEC
- Receptacle type: IPD1-04-D-K, SAMTEC
- Contact pins: CC79R-2024-01-L, SAMTEC
- Hand tool: CAT-HT-179-2024-11, SAMTEC
- Wire: AWG 20-24

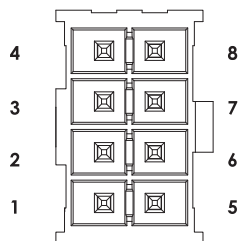

Fig.4-4: J3 connector terminals and functions

| Pin | Signal name | Function | Section |
|-----|---------------------|---|---------|
| 1 | Programmed Signal 1 | General Purpose Open collector Port 1 | 5.7.3 |
| 2 | PS_OK | Output for indication of the power supply status. High level is OK. | 5.7.4 |
| 3 | Trigger Out | Trigger output, positive true, pulse width: Min. 10usec | 8.5.2 |
| 4 | ILC | Enable /Disable the power supply output by dry-contact (short/open). | 5.7.2 |
| 5 | Shut Off (SO) | Input for shut off control of the power supply output. | 5.7.1 |
| 6 | Programmed Signal 2 | General Purpose Open collector Port 2 | 5.7.3 |
| 7 | IFC_COM | Isolated interface, common. | |
| 8 | Trigger In | CMOS level input for triggering power supply output. Positive edge, pulse width: Min. 10usec. | 8.5.1 |

Table 4-4: J3 connector terminals and functions

4.4 Front Panel Display Messages

Table 4-5 shows the various messages that will be shown on the display in different operating modes.

| Display Text | Text Description | Display Text | Text Description |
|--------------|------------------|---------------|------------------|
| <i>Abor</i> | ABORT | <i>ON</i> | ON |
| <i>AC</i> | AC | <i>ONCE</i> | ONCE |
| <i>Adr</i> | ADDRESS | <i>OTp</i> | OTP |
| <i>AUTO</i> | AUTO (RESTART) | <i>OVP</i> | OVP |
| <i>bAUd</i> | BAUD RATE | <i>PrLL</i> | PARALLEL |
| <i>bUS</i> | BUS | <i>P in 1</i> | PIN 1 |
| <i>Cont</i> | CONTINUE | <i>P in 2</i> | PIN 2 |
| <i>COUNT</i> | COUNTER | <i>POS</i> | POSITIVE |
| <i>Curr</i> | CURRENT | <i>PrOG</i> | PROGRAM |
| <i>CC</i> | CC | <i>Pr.dL</i> | PROTECTION DELAY |
| <i>CV</i> | CV | <i>PSd</i> | PS_OK DELAY |
| <i>d IS</i> | DISABLE | <i>rANG</i> | RANGE |
| <i>EnA</i> | ENABLE | <i>r.PAN</i> | REAL PANEL |
| <i>E.RES</i> | EXT.RESISTOR | <i>rECL</i> | RECALL |
| <i>Err</i> | ERROR | <i>rSt</i> | RESET |
| <i>E.VOL</i> | EXT.VOLTAGE | <i>rEu.</i> | REVISION |
| <i>Ext</i> | EXTERNAL | <i>232</i> | RS232 |
| <i>F.rSt</i> | FACTORY RESET | <i>485</i> | RS485 |
| <i>FA IL</i> | FAIL | <i>SAFE</i> | SAFE (START) |
| <i>FOLD</i> | FOLDBACK | <i>SAVE</i> | SAVE |
| <i>F.PAN</i> | FRONT PANEL | <i>SCPI</i> | SCPI |
| <i>F.Stb</i> | FUNCTION STROBE | <i>SO</i> | SHUT OFF |
| <i>GEN</i> | GEN LANGUAGE | <i>SEt</i> | SET |
| <i>HOLD</i> | HOLD | <i>SLAVE</i> | SLAVE |
| <i>HOST</i> | HOST | <i>SLAd</i> | SLAVE (ADVANCED) |
| <i>info</i> | INFORMATION | <i>SL</i> | SLAVE (BASIC) |
| <i>init</i> | INITIALIZE | <i>StEP</i> | STEP |
| <i>INtF</i> | INTERFACE | <i>trIG</i> | TRIGGER |
| <i>ILC</i> | INTERLOCK | <i>tr.dL</i> | TRIGGER DELAY |
| <i>IP</i> | IP | <i>tr.In</i> | TRIGGER IN |
| <i>LAN</i> | LAN | <i>tr.Ou</i> | TRIGGER OUT |
| <i>LANG</i> | LANGUAGE | <i>USb</i> | USB |
| <i>LOAD</i> | LOAD | <i>UVL</i> | UVL |
| <i>NEG</i> | NEGATIVE | <i>UVP</i> | UVP |
| <i>MAC</i> | MAC | <i>VOLt</i> | VOLTAGE |
| <i>MEMO</i> | MEMORY | <i>YES</i> | YES |
| <i>OFF</i> | OFF | | |

Table 4-5: Front Panel display messages

4.5 Navigating the Main Menu

4.5.1 Introduction

The Main Menu consists of three levels: Subsystem, Function and Parameter. To enter the Menu press the Menu button. The Menu LED illuminates and the display shows the Subsystem Menu. Navigate by rotating the Voltage encoder to scroll through the Subsystem list (first level). Repeat these actions to navigate the Functions list (second level). In the third level, the Voltage display shows the function and the Current display shows the parameter. Scroll the parameter list by rotating the Current encoder and press to select the desired parameter. When parameter is accepted, the display blinks once and exits to the previous level.

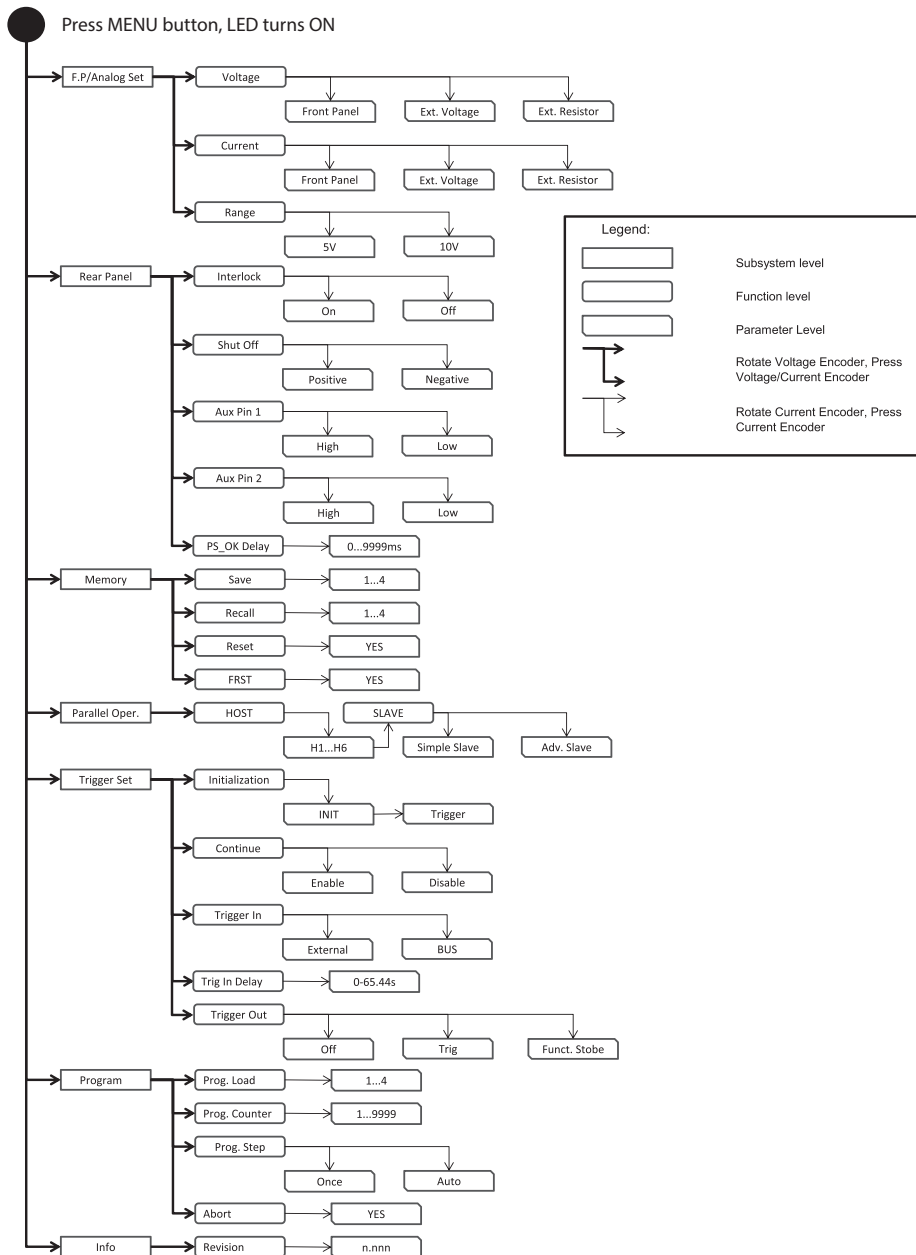

Fig.4-5: Main Menu diagram

4.5.2 Exiting the Main Menu

There are three ways to exit from Main Menu:

1. Press MENU button twice. MENU LED turns OFF. Display shows present status of power supply.
2. Press and hold MENU button 3sec. MENU LED turns OFF. Display shows present status of power supply.
3. No action for 15 sec. MENU LED turns OFF. Display shows present status of power supply.

4.6 Navigating Communication Menu

4.6.1 Introduction

The Communication Menu consists of two /three levels: Function level and Parameter level. To navigate the Communication Menu press REM button. The REM LED illuminates. The function menu item appears on the display. Navigate by rotating the Voltage encoder to scroll the function level. To select the desired function, press the Encoder button next to the display. In the Parameter level, the Voltage display shows the function and the Current display shows the parameter. Scroll the parameter list by rotating the Current encoder and press to select the desired parameter. When parameter is accepted, the display blinks once and exits to the previous level.

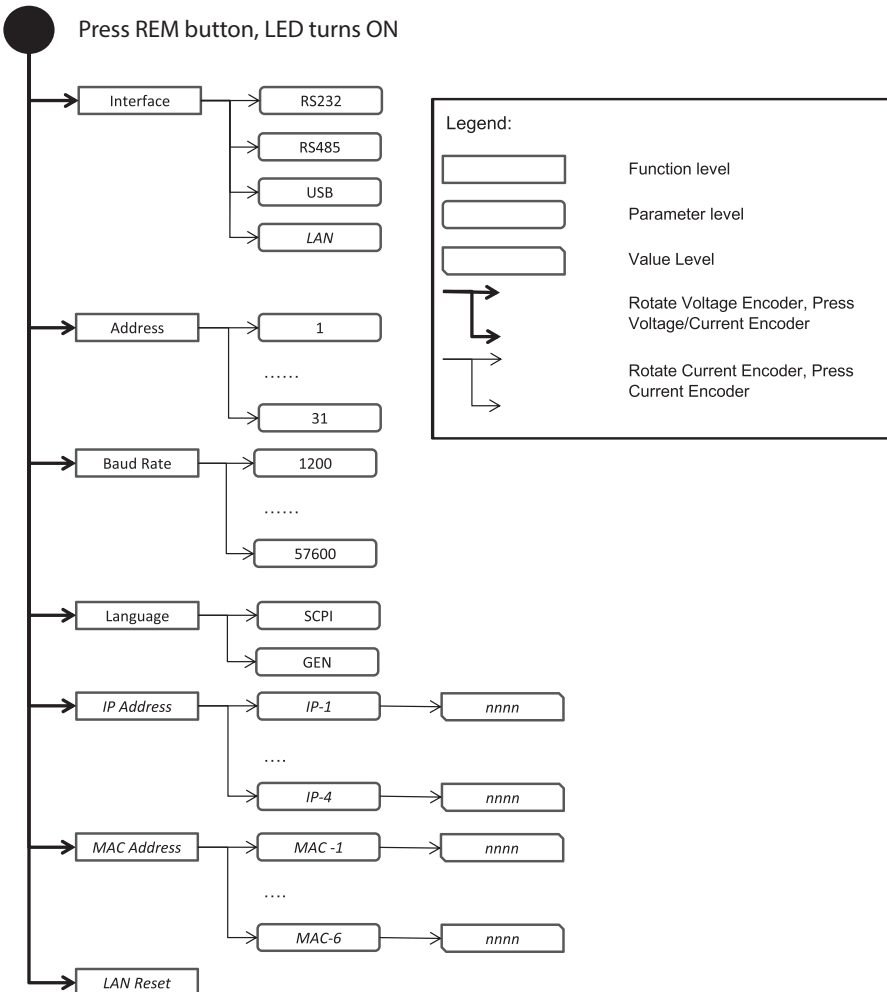

Fig.4-6: Communication Menu diagram

4.6.2 Exiting the Communication Menu

There are three ways to exit from REM menu:

1. Press REM button twice. REM LED turns OFF. Display shows present status of power supply.
2. Press and hold REM button 3sec. REM LED turns OFF. Display shows present status of power supply.
3. No action for 15 sec. REM LED turns OFF. Display shows present status of power supply.

4.7 Navigating the Protection Menu

4.7.1 Introduction

The Protection Menu consists of two levels: Function and Parameter.

To navigate the Protection Menu press PROT button. The PROT GREEN LED illuminates. The function menu item appears on the display. Navigate by rotating the Voltage encoder to scroll the function level. To select the desired function, press the Encoder button next to the display. Toggle the Voltage encoder to select either UVL or UVP functions.

In the Parameter level, the Voltage display shows the function and the Current display shows the parameter. Scroll the parameter list by rotating the Current encoder. Selection of a numerical parameter is automatic and the Encoder cannot be pressed. Press only to select Foldback parameter. When parameter is accepted the display blinks once and exits to the previous level.

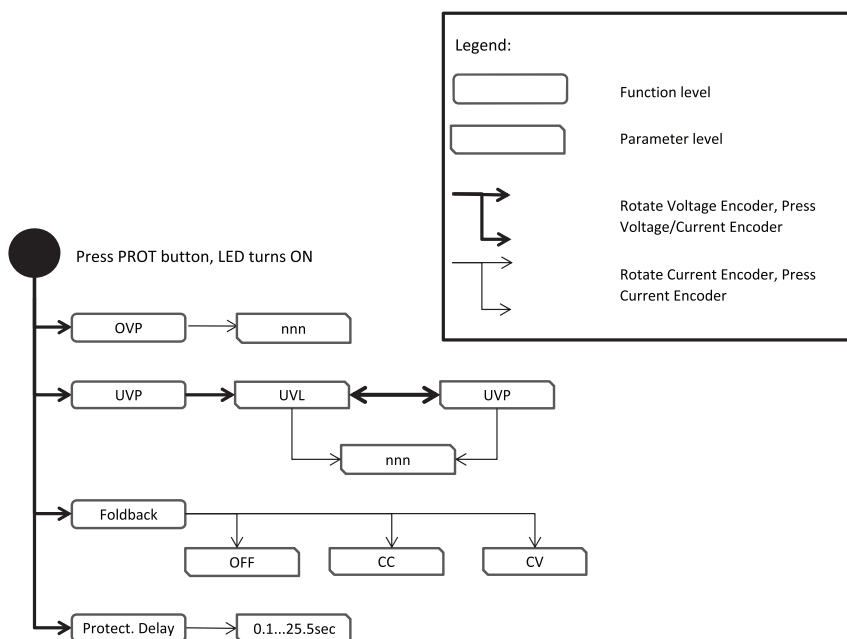

Fig.4-7: Protection Menu Navigation

4.7.2 Exiting the Protection Menu

There are three ways to exit the menu:

1. Press PROT button twice. PROT LED turns OFF. Display shows present status of power supply.
2. Press and hold PROT button 3sec. PROT LED turns OFF. Display shows present status of power supply.
3. No action for 15 sec. PROT LED turns OFF. Display shows present status of power supply.

5.1 Introduction

This Chapter describes the operating modes that do not require programming and monitoring the power supply via its communication interface. USB or RS232/RS485 or by remote analog signals. Ensure that the REM LED on the front panel is Off, (indicating Local mode). If the REM LED is On, press the front panel REM button to change the operating mode to local.

- For information regarding remote analog programming refer to Chapter 6.
- For information regarding usage of the serial communication port refer to Chapter 7.

5.2 Standard Operation

The power supply has two basic operating modes: Constant Voltage mode and Constant Current mode. The mode in which the power supply operates at any given time depends on the output voltage setting, output current limit setting and the load resistance.

5.2.1 Constant Voltage Mode and Voltage Setting

1. In constant voltage mode, the power supply regulates the output voltage at the selected value, while the load current varies as required by the load.
2. While the power supply operates in constant voltage mode, the CV LED on the front panel illuminates.
3. Adjustment of the output voltage can be made when the power supply output is enabled (Output On) or disabled (Output Off). When the output is enabled, simply rotate the Voltage encoder knob to program the output voltage. When the output is disabled, press the PREV button and then rotate the Voltage encoder to required value. The Voltage display will show the programmed output voltage for 5 seconds. Then "OFF" will appear on the Voltage display.
4. Resolution can be set to Coarse or Fine adjustment. Press FINE button to select between the lower and higher resolution. The FINE LED illuminates when the resolution is set to Fine.

NOTE:

If after completing the adjustment, the display shows a different value than the setting, the power supply may be at current limit. Check the load condition and the power supply current limit setting.

NOTE:

The maximum and minimum setting values of the output voltage are limited by the Over Voltage protection and Under Voltage limit setting. Refer to sections 5.3.2 and 5.3.3 for more details.

5.2.2 Constant Current Mode and Current Setting

1. In constant current mode, the power supply regulates the output current at the selected value, while the voltage varies with the load requirement.
2. While the power supply is operating in Constant Current mode, the CC LED illuminates.
3. Adjustment of the output current can be made when the power supply output is enabled (Output On) or disabled (Output Off). When the output is enabled, simply rotate the Current encoder knob to program the output current. When the output is disabled, press the PREV button and then rotate the Current encoder to required value. The Current display will show the programmed output current for 5 seconds. Then "OFF" will appear on the Voltage display.
4. Resolution can be set to Coarse or Fine adjustment. Press the FINE button to select between the Coarse and Fine adjustment. The FINE LED illuminates when the resolution is set to Fine.

5.2.3 Automatic Crossover

When the power supply operates in Constant Voltage mode, while the load current is increased to greater than the current limit setting, the power supply will automatically switch to Constant Current mode. If the load is decreased to less than the current limit setting, the power supply will automatically switch back to Constant Voltage mode.

5.2.4 Output On/Off Control

The Output On/Off enables or disables the power supply output. The Output On/Off can be activated from the front panel using the OUTPUT button or from the communication interface. The OUTPUT button can be pressed at any time (except in Front Panel Lock mode or when a Fault condition exists). When the output is disabled, the output voltage and current fall to zero and the Voltage display shows "OFF". Press the OUTPUT button to recover from Faults such as: OVP, UVP and FOLD faults, after the Fault conditions have been removed.

5.2.5 Safe Start and Auto-Restart Modes

At turn on, the power supply AC On/Off can start at last setting of Output Voltage and Current limit with the output enabled (Auto-restart), or it can start with the output disabled (Safe mode). Press and hold the OUTPUT button to toggle between Safe start and Auto-restart modes. The Voltage display will continuously cycle between "SAFE" and "AUTO" every 3 seconds. Releasing OUTPUT button while one of the modes is displayed, selects that mode. The default setting at shipment is in Safe mode.

- **Automatic Start Mode (AUTO)**
The power supply is restored to last operation setting. Upon start-up, the output is enabled or disabled according to the last setting.
- **Safe Start Mode (SAFE)**
The power supply is restored to last operation setting and sets the Output to Off state. At start-up, the output is disabled and the output voltage and current are zero. To enable the output, momentarily press OUTPUT button.

5.2.6 Viewing Software Revision

Via the Front Panel Menu, it is possible view installed software revision.

1. Press MENU button. MENU (GREEN) LED illuminates. "SEt" message appears on the Voltage display.
2. Rotate Voltage encoder until "INFO" message appears on Voltage Display.
3. Press Voltage encoder. The "REV." message appears on the display, and the installed software revision number appears on the Current display.

5.3 Alarms and Protective Functions

5.3.1 Introduction

There are several conditions that cause alarm (RED LED blinks). All alarms affect the output. When an alarm occurs, the respective fault will appear on the display and the alarm LED illuminates. It is possible that more than one fault (alarm) may be triggered but only the first will be shown on the display. If the second fault is still active when the first fault is removed, then the second fault will be displayed.

The following protective functions are incorporated in the power supply:

- OVP - Over Voltage Protection
- UVP - Under Voltage Protection
- ILC - Interlock
- FOLD - Fold Back Constant Current or Constant Voltage
- AC FAIL - AC Power shut down
- OTP - Over Temperature Protection

5.3.2 Over Voltage Protection

The OVP circuit protects the load in the event of a remote or local programming error or a power supply failure. The protection circuit monitors the voltage at the power supply sense points thus providing the protection level at the load. Upon detection of an Over Voltage condition, the power supply output will shut down.

5.3.2.1 Setting the OVP Level

The OVP can be set when the power supply output is Enabled (On) or Disabled (Off). The minimum setting level is 5% above the output voltage, or the value in Table 5-1, whichever is higher. The maximum setting level is shown in Table 5-1.

1. Press PROT button. PROT (GREEN) LED illuminates. "OVP" message appears on the Voltage display.
2. Press Voltage encoder. "OVP" message appears on the Voltage display and the Current display shows OVP setting level.
3. Rotate the Current encoder to adjust the OVP level.
4. Press PROT button twice or wait 15 sec. to return display to its previous state and then PROT LED turns OFF.

| Model | Max. OVP | Min. OVP |
|-------|----------|----------|
| 20V | 24.0V | 1.0V |
| 36V | 40.0V | 2.0V |
| 60V | 66.0V | 5.0V |
| 100V | 110.0V | 5.0V |

Table 5-1: Maximum/Minimum OVP setting levels

5.3.2.2 Resetting the OVP Circuit

To reset the OVP circuit after activation:

1. Reduce the power supply Output Voltage setting below the OVP set level.
2. Ensure that the load and the sense wiring is connected properly.
3. Four methods to reset the OVP circuit.
 - Press OUTPUT button.
 - AC recycle.
 - On/Off recycle by analog control (Interlock).
 - Send communication command to enable output.

5.3.3 Under Voltage Protection and Under Voltage Limit

The UVL function prevents output voltage setting below UVL set value. The UVP function prevents power supply operation if output voltage is below UVP set value. Upon detection of an Under Voltage condition, the power supply output will shut down. The UVL prevents adjustment of the output voltage below a certain limit. The combination of UVP/UVL and OVP functions, allows the user to create a protection window for sensitive load circuitry.

5.3.3.1 Setting the UVP/UVL Mode and Level

The UVP/UVL can be set when the power supply output is Enabled (On) or Disabled (Off). UVL and UVP setting values are limited at the maximum level to approximately 5% below the Output Voltage setting. Attempting to adjust the value above this limit will result in no response to the adjustment attempt. The minimum value setting is zero. If UVP setting is below 5% of rated output voltage, UVP will act as UVL. When UVP is selected, UVL will be disabled and Vice Versa.

1. Press PROT button. PROT (GREEN) LED illuminates. Current display shows "UVP" message.
2. Press Current Encoder. Voltage Display shows "UVP" or "UVL" message, Current display shows setting level.
3. Rotate the Voltage encoder to set "UVP" or "UVL", and then press the encoder. The display blinks once.
4. Rotate the Current encoder to adjust the level.
5. Press PROT button twice or wait 15 sec. to return display to its previous state and then PROT LED turns OFF.

5.3.3.2 Activated UVP Alarm

When the UVP is activated the power supply output shuts down. The Voltage and Current display shows "UVP FA IL" and the PROT red LED blinks.

5.3.4 Foldback Protection

Foldback protection will shut down the power supply output if power supply operation mode crosses over from CC to CV or from CV to CC, according to selected operation mode. There are three states of foldback protection. OFF (default), CV, CC. For CC to CV protection mode, setting should be CV. For CV to CC protection mode, setting should be CC.

5.3.4.1 Setting the Foldback Protection

The Foldback can be set when the power supply output is Enabled (On) or Disabled (Off).

1. Press PROT button. PROT (GREEN) LED illuminates. The "OVP" message appears on the Voltage display.
2. Rotate Voltage encoder until "FOLD" message appears on Voltage display.
3. Press Voltage encoder. "FOLD" message appears on Voltage Display, and on Current display shows "OFF" or "EL" or "EU" setting mode.
4. Rotate the Current encoder to adjust required mode and press to select. Display returns to the previous level.
5. Press PROT button to return display to its previous state (PROT LED turns OFF).

5.3.4.2 Activated FOLD Alarm

When the Foldback is activated the power supply output shuts off. The Voltage and Current display shows "FOLD FA IL" and the PROT red LED blinks.

5.3.5 Protection Delay

A delay can be set from between the time when a fault is detected and the output is disabled. It relates only in cases of UVP and Foldback protection.

NOTE:

UVP protection delay = 500ms + delay setting.

5.3.5.1 Setting the Protection Delay

1. Press PROT button. PROT (GREEN) LED illuminates. The "OVP" message, appears on the Voltage display.
2. Rotate Voltage encoder until "Pr.dL" message appears on Voltage display, and then press the Encoder.
3. The "Pr.dL" message appears on the Voltage Display. The Current display shows the value in seconds.
4. Rotate the Current encoder to adjust the delay. Protection delay setting range is 0...25.5sec.
5. Press Current encoder to select. Display blinks once and exists to the previous level.
6. Press PROT button once to return display to the previous state and PROT LED turns off.

5.3.6 Over Temperature Protection

The OTP circuit shuts down the power supply before the internal components can exceed their safe internal operating temperature. When an OTP shutdown occurs, the display shows "OTP FA IL" and the PROT LED blinks. Resetting the OTP circuit can be automatic (non-latched) or manual (latched) depending on if the power supply is in Safe or Automatic restart mode.

- **Safe start mode: The power supply stays off after the OTP condition has been removed. The display continue to shows "OTP FA IL" and the PROT LED continues to blink. To reset the OTP circuit, press OUTPUT button (or send Output Enable command).**
- **Auto-restart mode: The power supply recovers to it's last setting automatically after the OTP condition is removed.**

5.3.7 AC Fail Alarm

The AC Fail alarm indicates whether the AC input has been discounted or shut down. When any of these faults occur, the display shows "AC FA IL". Output power is disabled, and the PROT LED blinks.

- **Safe start mode: The power supply returns to "OFF", after the AC power returns.**
- **Auto-restart mode: The power supply recovers to it's last setting automatically when AC power returns.**

5.4 Series Operation

Power supplies of the same model can be connected in series to obtain increased output voltage. Split connection of the power supplies gives positive and negative output voltage.

WARNING:

When power supplies are connected in series, and the load or one of the output terminals is grounded, no point may be at a greater potential of +/- 100VDC from ground.

5.4.1 Series Connection for Increased Output Voltage

Two units are connected so that their outputs are summed. Set the current limit of each power supply to the maximum that the load can handle without damage. It is recommended that diodes be connected in parallel with each unit output to prevent reverse voltage during start up sequence or in case one of the units shuts down. Each diode should be rated to at least the power supply rated output voltage and output current. Refer to Fig.5-1 and Fig.5-2 for series operation with local and remote sensing.

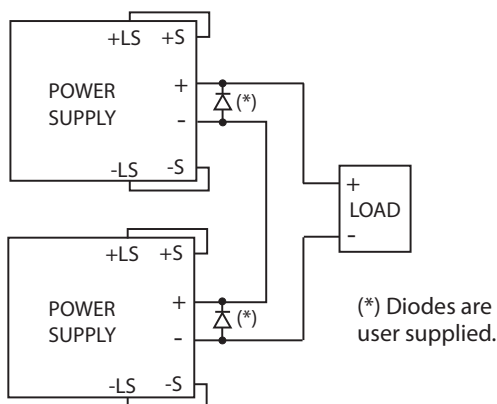

Fig.5-1: Series connection, local sensing

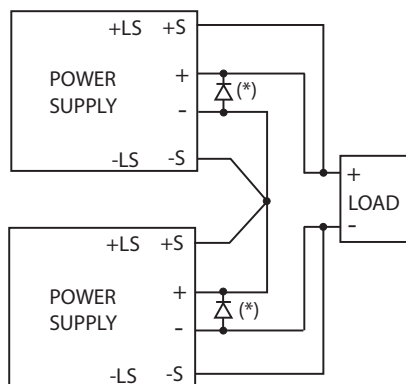

Fig.5-2: Series connection, remote sensing

5.4.2 Series Connection for Positive and Negative Output Voltage

In this mode, two units are configured as positive and negative output. Set the current limit of each power supply to the maximum that the load can handle without damage. It is recommended that diodes be connected in parallel with each unit output to prevent reverse voltage during start-up or in case one of the units shuts down. Each diode should be rated to at least the power supply rated output voltage and output current. Refer to Fig.5-3 for this operating mode.

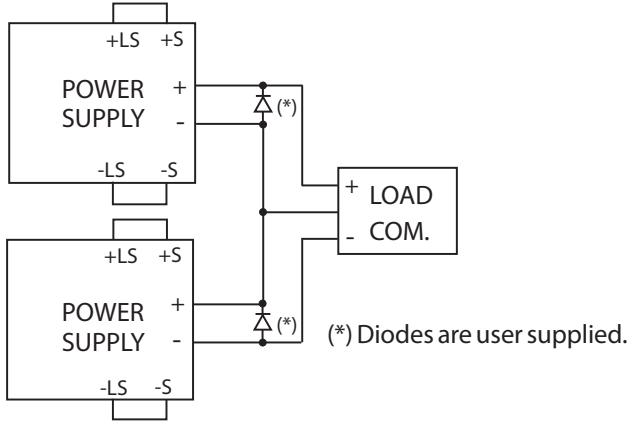

Fig.5-3: Series connection for positive/negative output voltages

5.4.3 Remote Programming in Series Operation

- Programming by external voltage: The analog programming circuits of this power supply are referenced to the negative Sense potential. Therefore, the circuits used to control each series connected unit must be separated and floated from each other. Refer to section 6.4
- Using the SO function and PS_OK signal : The Shut Off and PS_OK circuits are referenced to the isolated interface common, IFC_COM (J3-7). The IFC_COM terminals of the units can be connected to obtain a single control circuit for the power supplies connected in series.
- Programming by external resistor : Programming by external resistor is possible. Refer to section 6.5 for details.
- Programming via the Serial Communication port (RS232/RS485, USB): The Communication port is referenced to the IFC_COM which is isolated from the power supply output potential. Therefore power supplies connected in series can be chained using the Remote-In and Remote-Out connectors. Refer to Chapter 7 for details.

5.5 Parallel Operation

5.5.1 Introduction

Up to six units of the same Voltage and Current rating can be connected in parallel to provide up to six times the output current capability. One of the units operates as a master and the remaining units are slaves. The slave units are analog programmed by the master unit. In remote digital operation, only the master unit can be programmed by the computer while the slave units may be connected to the computer for voltage, current and status readback only.

The Master and Slave modes are stored in the power supply EEPROM when the AC power is turned off. The system will return to the Master/Slave mode upon re-application of AC power.

There are two methods to configure multiple supplies for parallel operation (basic and advanced). Refer to Section 5.5.2 and to Section 5.5.3 for detailed explanation. Parallel modes are selected via Front Panel menu. Refer to table 5-2.

| Subsystem Level | | Function Level | | Parameter Level | |
|-------------------------|-------------|---------------------------------------|-------------|---------------------|---------------|
| Description | Display | Function | Display | Description | Display |
| Parallel Operating Mode | <i>PrLL</i> | Host /Basic Slave / Advanced Slave | <i>HOST</i> | Single power supply | <i>H 1</i> |
| | | | | Master | <i>H2..H6</i> |
| | | | <i>SLVE</i> | Slave (Basic) | <i>SL</i> |
| | | | | Slave (Advanced) | <i>SLAd</i> |

Table 5-2. Parallel subsystem menu

| Display | Operating Mode |
|-------------|--------------------------------|
| <i>H 1</i> | Single unit (default) |
| <i>H2</i> | Master unit with 1 Slave unit |
| <i>H3</i> | Master unit with 2 Slave units |
| <i>H4</i> | Master unit with 3 Slave units |
| <i>H5</i> | Master unit with 4 Slave units |
| <i>H6</i> | Master unit with 5 Slave units |
| <i>SL</i> | Slave unit (Basic mode) |
| <i>SLAd</i> | Slave unit (Advanced mode) |

Table 5-2.1: Operation Setting Mode

5.5.2 Basic Parallel Operation

In this method, setting the units as Master and Slaves is made by the rear panel J1 connections and setup via Front Panel. Each unit displays its own output current and voltage. To program the load current, the Master unit should be programmed to the total load current divided by the number of units in the system. The master and slave units operate in a Daisy-Chain connection configuration. For further details about Daisy-chain connection refer to section 5.6. Refer to the following procedure to configure multiple supplies for basic parallel operation.

5.5.2.1 Master Unit Set Up

During operation, the master unit operates in CV mode, regulating the load voltage at the programmed output voltage. Connect the sensing circuit to local or remote sensing as shown in Fig.5-4 or Fig.5-5. Front Panel Main Menu Parallel mode is "H 1" as default.

1. Press MENU button.
2. Rotate Voltage encoder until "*PrLL*" appears on Voltage display, then press Voltage encoder.
3. Rotate Current encoder until "*H 1*" appears.
4. Press Current encoder to select "*H 1*", the display blinks once and returns to previous menu level.
5. Set the master unit output voltage to the desired voltage. Program the current limit to the desired load current limit, divided by the number of parallel units.
6. If there is more than one Slave unit connected to the Master, then set the PS_OK signal delay of the Master to 200msec. Refer to section 5.7.4 Power Supply OK Signal.

5.5.2.2 Slave Unit Set Up

When Slave mode is selected the power supply enters Current programming mode via external Voltage. Voltage and Current programming setting values are set to 105% of range. During operation the slave units operate as a controlled current source following the master output current. It is recommended that the power system is designed so that each unit supplies up to 95% of its current rating. This helps reduce imbalance which may occur by cabling and connections voltage drop.

1. Press MENU button
2. Rotate Voltage encoder until "PrLL" appears on Voltage display, then press Voltage encoder.
3. Rotate Current encoder until "SL" appears.
4. Press Current encoder to select "SL". Display blinks once and returns to previous display.
5. For wiring instructions, refer to Fig.5-4: Parallel connection with local sensing or Fig.5-5: Parallel connection with remote sensing.

5.5.2.3 Setting Over Voltage Protection

The master unit OVP should be programmed to the desired OVP level. In slave mode, the power supply is set to maximum as default.

5.5.2.4 Setting Foldback Protection

Foldback protection, if desired, may only be used with the master unit. When the master unit shuts down it programs the slave units to zero output voltage.

5.5.2.5 Connection to Load

In parallel operation, power supplies can be connected in local or remote sensing. Refer to Fig.5-4 and 5-5 for typical connections of parallel power supplies. The figures show connection of two units, however the same connection method applies for up to 6 units.

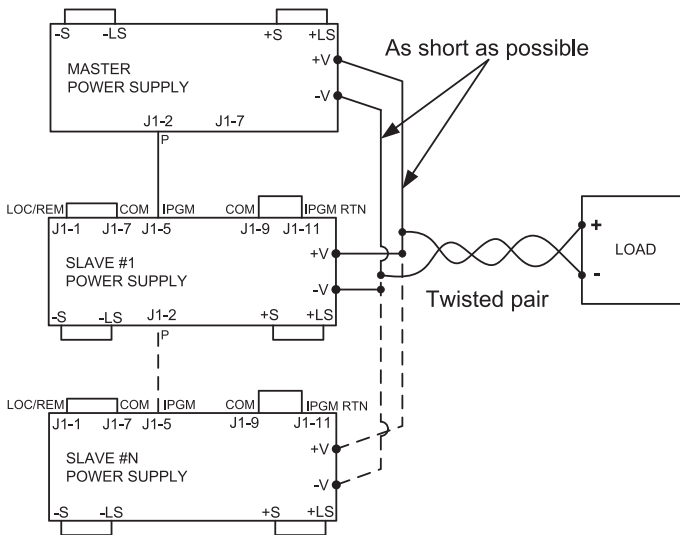

Fig.5-4: Parallel connection with local sensing

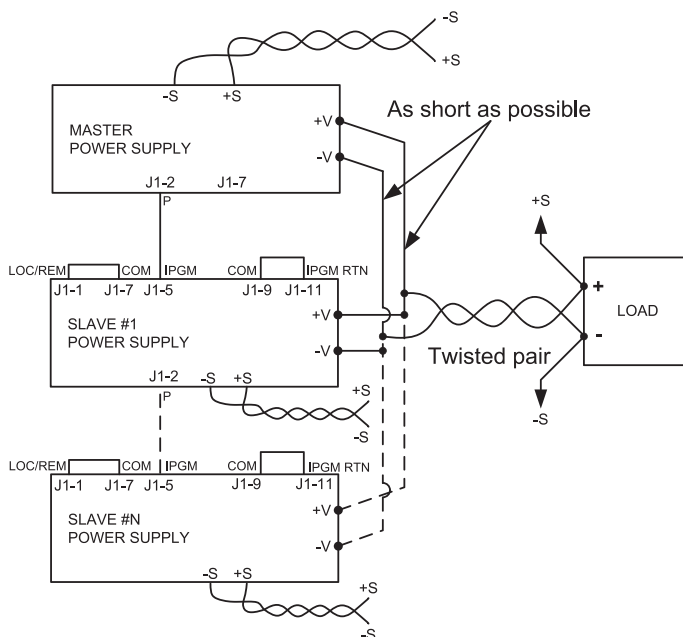

Fig.5-5: Parallel operation with remote sensing

CAUTION:

Make sure that the connection between -Vo terminals is reliable to avoid disconnection during operation. Disconnection may cause damage to the power supply.

NOTE:

With local sensing it is important to minimize the wire length and resistance. Also the positive and negative wire resistance should be as close as possible to each other to achieve current balance between power supplies.

5.5.3 Advanced Parallel Operation

In Advanced Parallel operation the master unit displays the total current of all units connected in Parallel. The slave units display "ON SLAVE". The master and slave units operate in a Daisy-Chain connection configuration. For further details about Daisy-chain connection refer to section 5.6.

In the Advanced Parallel mode, the total current is programmed and reported by the master unit. The Current display accuracy is 2%+/- 1 count. In cases where higher accuracy is required, it is recommended to use Basic Parallel operation mode.

5.5.3.1 Master Unit Set Up

During operation, the master unit operates in CV mode, regulating the load voltage at the programmed output voltage. Connect the sensing circuit to local or remote sensing as shown in Fig.5-4 or Fig.5-5.

1. Press MENU button.
2. Rotate Voltage encoder until "P-LL" appears on Voltage display, then press Voltage encoder.
3. Rotate Current encoder and select required 'n' value (from 2-6) for example, "H3". The display blinks once and returns to previous level. Refer to Table 5-2.1.
4. Set the master unit output voltage to the desired voltage. Program the current limit to the desired load current limit, divided by the number of parallel units.
5. Recycle AC power.
6. If there is more than one Slave unit connected to the Master, then set the PS_OK signal delay of the Master to 200msec. Refer to section 5.7.4 Power Supply OK Signal.

5.5.3.2 Slave Unit Set Up

When Advanced Slave mode is selected the power supply enters Current programming mode via external Voltage. Voltage and Current programming setting values are set to 105% of range. During operation the slave units operate as a controlled current source following the master output current. It is recommended that the power system is designed so that each unit supplies up to 95% of its current rating. This helps reduce imbalance which may occur by cabling and connections voltage drop.

When a unit is programmed to Advanced Slave mode it enters Remote mode with Local Lockout. In this mode, Front panel controls are disabled to prevent accidental setting change except Menu parallel setting and factory reset. Communication commands are disabled. Power supply responds only upon query.

1. Press MENU button.
2. Rotate Voltage encoder until "P-LL" appears on Voltage display, then press Voltage encoder.
3. Rotate Current encoder until "SLAd" appears.
4. Press Current encoder to select "SLAd". Display blinks once and returns to previous level.
5. Recycle AC power.
6. For wiring instructions, refer to Fig.5-4: Parallel connection with local sensing or Fig.5-5: Parallel connection with remote sensing and Section 5.6: Daisy-Chain connection.

NOTE:

To release units from Advanced mode select "H I".

5.6 Daisy-Chain Connection

It is possible to configure a multiple power supply system to shut down all units when a fault condition occurs in one of the units. When the fault is removed, the system recovers according to a preset state: Safe start mode or Automatic restart.

Set signal "SD" to positive logic via Front panel (refer to section 5.7.1) . If a fault occurs in one of the units it's "PS_OK" signal will be set to low level and the display will indicate the fault. The other units will shut off and their displays will indicate "SD". When the fault condition is removed, the units will recover to their last setting according to their respective Safe start or Auto-restart setting.

Fig.5-6 shows connection of three units, however the same connection method applies to systems with more units.

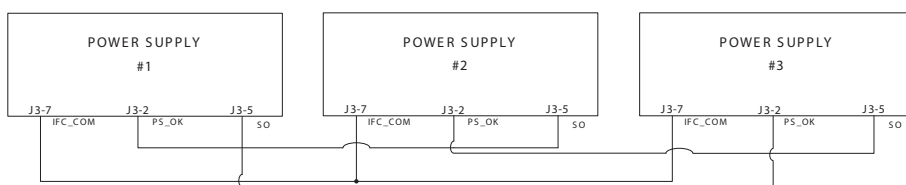

Fig.5-6: Daisy-Chain connection

5.7 Rear Panel (J3 Connector) Functions and Settings

| Subsystem Level | Display | Function Level | Display | Parameter Level | Display | Description |
|-----------------|---------|------------------|---------|-----------------|---------|---|
| Rear Panel | r.PAN | Interlock | ILC | Enable (ON) | ON | Enable/Disable interlock function (Analog ON/OFF) |
| | | | | Disable (OFF) | OFF | |
| | | Shut OFF | SD | Positive | POS | Positive (polarity) same as PS_OK signal |
| | | | | Negative | NEG | |
| | | Programmed PIN 1 | PIN1 | High | Hi | Open collector |
| | | | | Low | Lo | |
| | | Programmed PIN 2 | PIN2 | High | Hi | Open collector |
| | | | | Low | Lo | |

Table 5-3: Rear panel subsystem menu

5.7.1 External Shut Off Function

SO signal serves as Output Shut Off. It is an optically isolated signal from the power supply output. Connection to the signal is made via pin J3-5 (Shut Off) and pin J3-7 (IFC_COM). The SO pin accepts a 4V to 15V signal or Open-Short contact to disable or enable the power supply output. The SO function will be activated only when a transition from On to Off is detected after applying AC power to the unit. Thus, in Auto start mode, the output will be enabled after applying AC power, even if SO is in Off level. After On to Off transition is detected, the SO will enable or disable the power supply output according to the signal level or the short/open applied to J3. When the external SO is triggered, the power supply will display "50" on the voltage display but the PROT LED will not illuminate.

The external shutdown is useful when using the power supply as part of a larger test system in which digital or analog control is required or in "Daisy-Chain".

The SO control logic can be selected via the Front panel as follows:

1. Press MENU button. MENU (GREEN) LED illuminates. "5E1" message appears on the Voltage display and "r.PPn" message appears on the Current display.
2. Press Current encoder. The "50" message appears on the Current display.
3. Press the Current encoder again. The "50" message appears on the Voltage display. Parameter "P05" or "nEE" appears on the Current display.
4. Rotate and press the Current encoder to select the required parameter.
5. For signal details refer to Table 5-4.

| SO logic | SO signal level (J3-5 - J3-7) | Output status |
|-------------------------------|-------------------------------|---------------|
| Positive (as PS_OK) (default) | 4-15V or Open | On |
| | 0-0.6V or Short | Off 50 |
| Negative | 4-15V or Open | Off 50 |
| | 0-0.6V or Short | On |

Table 5-4: SO logic selection

5.7.2 Interlock Function - Analog On/Off. (Enable/Disable)

Interlock signal serves as Output Enable/Disable via switch or relay. Use the Interlock function to enable or disable the output as emergency shutoff or door open switch. It is an optically isolated signal from the power supply output. Connection to the signal is made via pin J3-4 (ILC) and pin J3-7 (IFC_COM).

The ILC control logic can be selected via the Front panel as follows:

1. Press MENU button. MENU (GREEN) LED illuminates. "5E1" message appears on the Voltage display. "r.PPn" message appears on Current display.
2. Press Current encoder and the "iLL" message appears on the display.
3. Press Voltage encoder and "iLL" message appears on the display. The parameters "0FF" or "0n" appear on the Current encoder display.
4. Rotate and press the Current encoder to select desired parameter.
5. For signal details refer to Table 5-5.

| Front Panel ILC Setting | ILC Input | Power Supply Output | Display | Alarm LED |
|-------------------------|---------------|---------------------|-----------------|-----------|
| OFF - Default | Open or Short | On | Voltage/Current | Off |
| ON | Open | Off | Err | Blinking |
| | Short | On | Voltage/Current | Off |

Table 5-5: Interlock functions and settings

CAUTION:

To prevent possible damage to the unit, do not connect any of the Enable /Disable inputs to the positive or negative output potential.

NOTE:

Safe Start mode - If the Interlock fault condition clears while units are in safe start mode, the power supply stay to Off mode.

Auto Restart mode - The output will automatically return to previous settings.

5.7.3 Auxiliary Programmed Function Pin 1 and Pin 2

The programmed signal Pin 1 (J3-1) and Pin 2 (J3-6) are open collector, maximum input voltage 25V and maximum sink current 100mA, and can be controlled via Front panel or software.

Pin 1 or Pin 2 settings are made as follows:

1. Press MENU button. MENU (GREEN) LED illuminates. The "r.PPn" message appears on the Current display.
2. Press Current encoder and the "iL" message appears on the Voltage display.
3. Rotate Voltage encoder until "P 1 / P 2" message appears on display. Press Encoder to select the desired Pin.
4. Voltage display shows the selected Pin number.
5. Rotate the Current encoder to toggle between "H" (High) or "L" (Low).
6. Press Current encoder to select desired parameter.
7. Press MENU button twice to return display to it's previous state. MENU LED turns OFF.

CAUTION:

Do not connect Pin 1 and Pin 2 to a voltage source higher than 25V. Always connect Pin 1 and Pin 2 to the voltage source with a series resistor to limit the sink current to less than 100mA.

5.7.4 Power Supply OK Signal

PS_OK signal indicates fault condition in the power supply. It is a TTL signal output at J3-2, referenced to IFC_COM at J3-7 (Isolated Interface Common). When a fault condition occurs, PS_OK level is low, with maximum sink current of 1mA. When no fault condition occurs, PS_OK level is high with maximum source current of 2mA. All conditions when output status is disabled sets PS_OK to low level.

The PS_OK signal at high level can be delayed via Front panel setting. This function is used to prevent signal rise before output reaches set value.

PS_OK delay setting:

1. Press MENU button. MENU (GREEN) LED illuminates. The "r.PPP" message appears on the Current display.
2. Press Current encoder, "iLL" message appears on the Voltage Display.
3. Rotate Voltage encoder until "P5d" message appears and press Encoder.
4. Parameter delay time in mSec appears on the Current display
5. Rotate the Current encoder to adjust the setting level. PS_OK delay range is from 0 to 9999mSec.
6. Press Current encoder to select desired level.
7. Press MENU button twice to return display to it's previous state. MENU LED turns OFF.

5.8 Rear Panel (J1 Connector) Functions

5.8.1 CV/CC Signal

The CV/CC signal indicates the operating mode of the power supply. Constant Voltage or Constant Current. CV/CC signal is an open collector output with a 36V parallel zener, at J1-8, referenced to the COM at J1-7 (connected internally to the negative sense potential). When the power supply operates in Constant Voltage mode, CV/CC output is open. When the power supply operates in Constant Current mode, CV/CC signal output is low (0-0.6), with maximum 10mA sink current.

CAUTION:

Do not connect CV/CC signal to a voltage source higher than 30VDC. Always connect CV/CC signal to the voltage source with a series resistor to limit the sink current to less than 10mA.

5.9 Parameter Setting Memory

Power Supply has four memory configuration modes:

| Subsystem Level | Display | Function Level | Display | Parameter Level | Display | Description |
|-----------------|---------|----------------|---------|-----------------|---------|---------------------------------------|
| Memory | MEM | SAVE | SAVE | 1...4 | 1...4 | Save setting in non volatile memory |
| | | RECALL | RECALL | 1...4 | 1...4 | Recall setting in non volatile memory |
| | | RST | RST | YES | YES | Reset setting |
| | | FRST | FRST | YES | YES | Set factory default setting |

Table 5-6: Parameter Setting Memory

5.9.1 Default Setting

For factory default parameters refer to Table 5-7.

1. Press MENU button. MENU (green) LED illuminates. "SET" message appears on the Voltage display.
2. Rotate Voltage encoder until "MEM" message appears on Voltage display.
3. Press Voltage encoder. "SAVE" message appears on Voltage Display.
4. Rotate Voltage encoder until "RST" message appears on Voltage display.
5. Press Voltage encoder. "FRST" message appears on Voltage Display, and "YES" appears on Current display .
6. Press the Current encoder "HOLD" Message appears on the display for 1sec. The display blinks once and returns to previous level.
7. Press MENU button twice to return display to previous state, MENU LED turns OFF.

NOTE:

No response for FRST command. After this command the power supply loses communication because of communication setting change.

5.9.2 Reset

For Reset parameters refer to Table 5-7.

1. Press MENU button. MENU (green) LED illuminates. "SET" message appears on the Voltage display.
2. Rotate Voltage encoder until "MEM" message appears on Voltage display.
3. Press Voltage encoder. "SAVE" message appears on Voltage Display.
4. Rotate Voltage encoder until "RST" message appears on Voltage display.
5. Press Voltage encoder. "FRST" message appears on Voltage Display. "YES" appears on the Current display .
6. Press the Current encoder, display blinks and returns to previous level.
7. Press MENU button twice to return display to previous state, MENU LED turns OFF.

5.9.3 Last Setting Memory

Memory stores last set parameters when AC switch is turned off.

For last set parameters refer to Table 5-7.

5.9.4 Save <1..4>

This command saves the present state of the power supply to a specified location in memory (refer to Table 5-7). Up to 4 states can be stored. Storage locations 1 through 4 are in nonvolatile memory.

Save Front panel setting:

1. Press MENU button. MENU (green) LED illuminates. "SEt" message appears on the Voltage display.
2. Rotate Voltage encoder until "iEiD" message appears on Voltage display.
3. Press Voltage encoder. "SAUE" message appears on Voltage display.
4. Press Voltage encoder. "SAUE" message appears on Voltage display. Numbers "1..4" appear on Current display.
5. Rotate the Current encoder to select required number value and then press the Current encoder. Display blinks and returns to previous level.

5.9.5 Recall <1..4>

This command recalls the present state of the power supply from a specified location in memory (refer to Table 5-7). Up to 4 states can be stored. Storage locations 1 through 4 are in nonvolatile memory.

Recall front panel setting:

1. Press MENU button. MENU (green) LED illuminates. "SEt" message appears on the Voltage display.
2. Rotate the Voltage encoder until "iEiD" message appears on Voltage display.
3. Press Voltage encoder. "rEL" message appears on Current display.
4. Press Current encoder. Numbers "1..4" appear on Current display.
5. Rotate the Current encoder to select required number value and then press the Current encoder. Display blinks and returns to previous level.

| Parameter | Factory Default | Resetting | Last setting | Save & Recall |
|---------------------------------------|-----------------|----------------|--------------|---------------|
| Output Status | OFF | OFF | + | + |
| Voltage Set-point | 0V | 0V | + | + |
| Current Set-point | MAX | 0A | + | + |
| Fold Back mode | OFF | OFF | + | + |
| Over Voltage Protection OVP | MAX | MAX | + | + |
| Under Voltage Level/ Protection mode | OFF (UVL) | OFF (UVL) | + | + |
| Under Voltage Level/ Protection level | 0V | 0V | + | + |
| Auto Start Mode | SAFE | SAFE | + | + |
| Control pin 1 | 1 | 1 | + | + |
| Control pin 2 | 1 | 1 | + | + |
| Input Trigger Source | EXT | EXT | + | - |
| Protection Delay | 0mS | 0mS | + | + |
| Voltage Programming Mode | Digital | - | + | - |
| Current Programming Mode | Digital | - | + | - |
| Programming and Monitor Range | 5V | - | + | - |
| Current Share Mode {Master Slave} | (Master H1) | - | + | - |
| Interlock (Inhibit) | OFF (disabled) | OFF (disabled) | + | - |
| Shutdown Logic | 1 (positive) | - | + | - |
| Remote mode | LOC | LOC | + | + |
| Communication Mode | RS232 | - | + | - |
| Address | 6 | - | + | - |
| Baud Rate | 9600 | - | + | - |
| Language | SCPI | - | + | - |
| Lock/unlock front panel | Unlock | - | + | - |
| LIST and WAVE subsystems | OFF | OFF | - | - |
| Program Step | AUTO | AUTO (COUNT 1) | - | - |
| Trigger Out | OFF | OFF | + | + |
| PS_OK delay | 0mS | 0mS | + | + |
| Enable registers | Clear | Clear | - | - |
| Event registers | Clear | Clear | - | - |

Table 5-7: Memory parameters.

6.1 Introduction

The Rear Panel connector J1 allows the user to program the power supply output voltage and current limit with an analog device. J1 also provides monitoring signals for output voltage and output current. The programming range and monitoring signals range can be selected between 0-5V or 0-10V using the Front Panel Menu Subsystem Level.

| Subsystem Level | Display | Function Level | Display | Parameter Level | Display | Description |
|--------------------------|---------|----------------------|---------|--|---------|---|
| SET | SEt | Voltage limit source | VOLT | Front Panel (Digital) | F.PAN | Parameter settings in Analog/Digital control mode, Voltage channel. |
| | | | | Ext. Voltage | E.VOL | |
| | | | | Ext. Resist. | E.RES | |
| | | Current limit source | CURR | Front Panel (Digital) | F.PAN | Parameter settings in Analog/Digital control mode, Current channel. |
| | | | | Ext. Voltage | E.VOL | |
| | | | | Ext. Resist. | E.RES | |
| Source and monitor range | RANGE | 5/10 (V/KΩ) range | 5 | Control by external Voltage/Resistor, Range 5/10 | | |

Table 6-1: MENU. Analog Programming Setting

CAUTION:

COM (J1-7,9) and VPGM_RTN (J1-12) terminals of J1 are connected internally to the -Sense potential (-S). Do not connect these terminals to any potential other than -Sense (-S), as it may damage the power supply.

6.2 Local/Remote Analog Control

Contact J1-1 (Fig.4-3, item 1) accepts TTL signal or Open-Short contact (Referenced to J1-7,9) to select between Local or Remote Analog programming of the output voltage and current limit. In Local mode, the output voltage and current limit can be programmed via the front panel Voltage and Current encoders or via the Communication interface. In Remote Analog mode, the output voltage and current limit can be programmed by analog voltage or by programming resistors via J1 contacts 6 and 5. Refer to Analog Programming Setting Table 6-2.

6.3 Local/Remote Analog Indication

Contact J1-4 (Fig.4-3, item 4) is an open collector output that indicates if the power supply is in Local mode or in Remote Analog mode. To use this output, connect a pull-up resistor to a voltage source of 30Vdc maximum. Choose the pull-up resistor so that the sink current will be less than 5mA when the output is in low state. J1-4 signal will be low if J1-1 is low and at least one of Analog control modes are selected. Refer to Analog Programming Setting Table 6-2.

| J1-1 LOC/REM SELECT | Front Panel selection | Front Panel selection | J1-4 LOC/REM MON |
|---------------------|-----------------------|-----------------------|------------------|
| OPEN "1" | Not applicable | Not applicable | Open |
| TTL "0" or Short | F.PAN | F.PAN | Open |
| | E.VOL or E.RES | F.PAN | 0~0.6V |
| | F.PAN | E.VOL or E.RES | 0~0.6V |
| | E.VOL or E.RES | E.VOL or E.RES | 0~0.6V |

Table 6-2: Local/Remote Analog Control and Indication

6.4 Remote Voltage Programming of Output Voltage and Current

Remote Programming settings are as follows:

1. For Voltage Analog Programming wiring refer to Fig.6-1.
2. Short pins J1-1 to J1-7.
3. Press MENU button. MENU (GREEN) LED illuminates. "SEL" message appears on Voltage display.
4. Press Voltage encoder. "VOLT" message appears on Voltage Display and "CURR" appears on the Current display.
5. Press Voltage encoder to select programming of the Output Voltage, or press Current encoder to select programming of the Output Current.
6. The selected function appears on the Voltage display. Parameter "FRNG" or "E.VOL" or "E.CES" appears on the Current display.
7. Rotate and press the Current encoder to select "E.VOL".
8. "VOLT" message appears on Voltage Display and "CURR" appears on the Current display.
9. Rotate Voltage encoder until "FRNG" appears on display. Press on the relevant Encoder.
10. "FRNG" appears on Voltage display and "5" (5V) or "10" (10V) appears on Current display.
11. Rotate and press the Current encoder to select the desired programming Voltage range.
12. Press MENU button twice to return display to it's previous state. MENU LED turns OFF

CAUTION:

To maintain the isolation of power supply and prevent ground loops, use an isolated programming source when operating the power supply via remote analog programming at J1 connector.

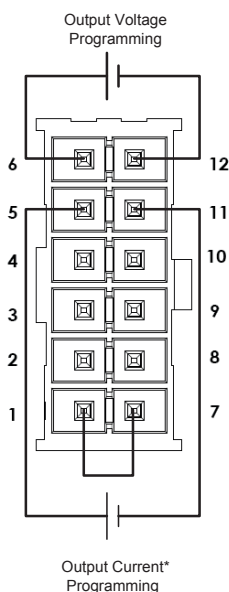

Fig.6-1: J1-Remote Voltage Programming Connection

*Max. output current is limited by front panel current setting.

6.5 Remote Resistor Programming of Output Voltage and Output Current

For resistive programming, internal current sources, for output voltage and/or output current control, supply 1mA current through external programming resistors connected between J1-6 and J1-12 and between J1-5 and J1-1, J1-7 & J1-11. The voltage across the programming resistors is used as a programming voltage for the power supply. Resistance of 0~5Kohm or 0~10Kohm can be selected to program the output voltage and current limit from zero to full scale. A variable resistor can control the output over the entire range, or a combination of variable resistors and series/parallel resistors can control the output over restricted portion of the range.

Remote Programming settings as follows:

1. For Resistor Analog Programming wiring refer to Fig.6-2.
2. Short pins J1-1 to J1-7.
3. Press MENU button. MENU (GREEN) LED illuminates. "SEL" message appears on Voltage display.
4. Press Voltage encoder. "VOLT" message appears on Voltage Display and "CURR" appears on the Current display.
5. Press on the Voltage encoder to select programming the Output Voltage, or Press Current encoder to select programming of the Output Current.
6. The selected function appears on the Voltage display. Parameter "FRAN" or "E.VOL" or "E.RES" appears on the Current display.
7. Rotate and press the Current encoder on to select "RES".
8. "VOLT" message appears on Voltage Display and "CURR" appears on the Current display.
9. Rotate Current encoder until "RANG" appears on the display. Press on the relevant Encoder.
10. "RANG" appears on Voltage display and "5" (5K) or "10" (10K) appears on Current display.
11. Rotate and press the Current encoder to select the desired programming Resistance range.
12. Press MENU button twice to return display to the previous state. MENU LED turns OFF.

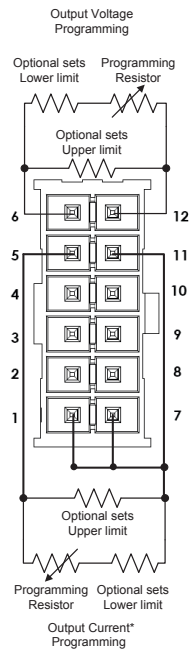

Fig.6-2: J1-Remote Resistor Programming Connection

*Max. output current is limited by front panel current setting.

NOTES:

1. In Remote analog mode: the output voltage cannot be set by the Voltage encoder. The output voltage limit is set to 5% over the model-rated maximum value. The over current limit (OCL) is set by the Current encoder to 5% over the model-rated maximum value.
2. The power supply will operate within the extended range, however it is not recommended to operate the power supply over its voltage and current rating and performance is not guaranteed.
3. Communication: In Remote analog mode, power supply parameters can be programmed and read back via the Communication port except output voltage and current settings.
4. To maintain the temperature stability specification of the power supply, the resistors used for programming should be stable and low noise resistors, with a temperature coefficient of less than 50ppm.
5. Radiated emissions, FCC requirements: FCC requirements for radiated emissions, use a shielded cable for the analog control signals. In cases using a nonshielded cable, attach an EMI ferrite suppressor to the cable, as close as possible to the power supply.
6. Front panel PREV button: Use PREV button to display the output voltage and current settings defined by the Encoders or Communication.

6.6 Programming Monitoring of Output Voltage (V_MON) and Current (I_MON)

The J1 connector, located on the rear panel provides analog signals for monitoring the output voltage and output current. Selection of the voltage range between 0-5V or 0-10V is made via Front Panel.

The monitoring signals represent 0 to 100% of the power supply output voltage and output current. The monitor outputs have 500 ohm series output resistance.

Ensure that the sensing circuit has an input resistance of greater than 500 Kohm or accuracy will be reduced.

Range selection as follows:

1. Press MENU button. MENU (GREEN) LED illuminates. "SET" appears on Voltage display.
2. Press Voltage encoder. "VOLT" message appears on Voltage Display and "CUR" appears on the Current display.
3. Rotate Voltage encoder until "RANGE" appears on display. Press on the relevant Encoder.
4. "RANGE" appears on Voltage display and "5" (5V) or "10" (10V) appears on Current display.
5. Rotate and press the Current encoder to select the desired monitoring Voltage range.
6. Press MENU button twice to return display to the previous state. MENU LED turns OFF.

7.1 Introduction

This chapter describes the set-up, operation, commands and communication protocol of RMX-410x power supplies via serial communication interfaces: RS232, RS485 or USB.

7.2 Configuration

| Function Level | Display | Parameter Level | Display | |
|----------------|---------|-----------------|---------|------|
| Interface | INTEF | 232 | 232 | |
| | | 485 | 485 | |
| | | USB | USB | |
| | | LAN | LAN | |
| Address | Adr | 1...31 | 1...31 | |
| Baud Rate | baud | 1200..57600 | 57.6 | |
| Language | LANG | SCPI | SCPI | |
| | | GEN | GEN | |
| IP Address | IP | IP1--IP4 | IP 2 | 1096 |
| MAC Address | MAC | MAC1-MAC6 | MAC 6 | 3345 |
| LAN Reset | reset | Yes | YES | |

Table 7-1: Front panel setup

7.2.1 Default Setting

Refer to Table 5-7: Memory parameters.

7.2.2 Address Setting

The power supply address can be set to any address between 1 and 31.

1. Press REM button. The REM LED illuminates. "Adr" message appears on the Current display.
2. Press Current encoder. Voltage display shows "Adr" and Current display shows present address.
3. Rotate the Current encoder to select required address.
4. Press Current encoder to enter selected parameter to memory.
5. When parameter is accepted the display blinks once and returns to the previous level.

7.2.3 Communication Interface Selection

The RMX-410x power supply can be configured for RS232, RS485 or USB(*) communication interface.

1. Press REM button. The REM LED illuminates. "INTEF" message appears on the Voltage display.
2. Press Voltage encoder. Voltage display shows "INTEF" and Current display shows communication interface.
3. Rotate the Current encoder to select the required interface.
4. Press Current encoder to enter selected parameter to memory.
5. When parameter is accepted the display blinks once and returns to the previous level.

* Do not connect or disconnect the USB cable when the PS is operating.

7.2.4 Baud Rate Setting

Seven optional rates are possible: 1200, 2400, 4800, 9600, 19200, 38400, 57600.

1. Press REM button. The REM LED illuminates. "iNtF" message appears on the Voltage display.
2. Rotate Voltage encoder until Voltage display shows "bAUd".
3. Press Voltage encoder. Voltage display shows "bAUd" and Current display shows baud rate.
3. Rotate the Current encoder to select required baud rate.
4. Press Current encoder to enter selected parameter to memory.
5. When parameter is accepted the display blinks once and returns to the previous level.

7.2.5 Language Selection (RS232/RS485, USB)

The RMX-410x implements SCPI standard command line interface to remotely control the power supply. Additionally, a small subset of legacy GEN commands has been provided for ease of use and backwards compatibility.

1. Press REM button. The REM LED illuminates. "iNtF" message appears on the Voltage display.
2. Rotate Voltage encoder until Voltage display shows "LANG".
3. Press Voltage encoder. Voltage display shows "LANG" and Current display shows language.
3. Rotate the Current encoder to select required language.
4. Press Current encoder to enter selected parameter to memory.
5. When parameter is accepted the display blinks once and returns to the previous level.

7.2.6 Setting Unit in Remote, Local Lockout or Local Mode

Local mode:

When the power supply is in local mode, it can receive queries. If a query is received, the power supply will reply and remain in Local mode. Serial commands may be sent to set and read the status registers while the unit is in Local mode. If the Enable registers are set the power supply will transmit SRQ's while in Local mode.

Remote mode:

If a command is received that affects the output or a Remote command is received, the power supply will perform the command and change to Remote mode.

When the power supply is in Remote mode, REM LED illuminates and parameters cannot be changed via the front panel. Return to Local mode by pressing the front panel REM Button or via communication command.

Local Lockout mode:

When the power supply is in Local Lockout mode, REM LED illuminates and parameters cannot be changed via the front panel. It is possible to return to Remote mode, only with a communication command or by AC power recycle.

7.3 Rear Panel RS232/485 Connector

The RS232/485 interface is accessible through the Rear panel RS232/485 IN and RS485 OUT connectors. The connectors are 8 contact RJ-45. The IN and OUT connectors are used to connect power supplies in a RS232 or RS485 chain to a controller. Refer to Fig.7-1 for IN/OUT connectors.

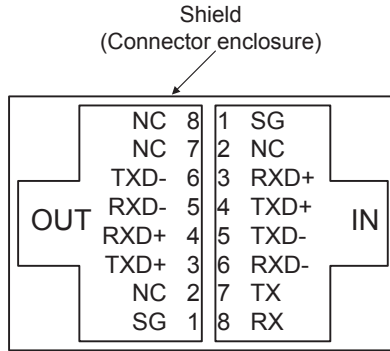

Fig.7-1: J4 rear panel IN/OUT connectors pinout

NOTE:

Tx and Rx are used for RS232 communication. Txd +/- and Rxd +/- are used for RS485 communication. Refer to RS232 and RS485 cable descriptions for connection details.

7.4 Connecting Power Supply to RS232 Or RS485 BUS

Connect rear panel IN connector to the controller RS232 or RS485 port using a suitable shielded cable. Refer to Figures 7-3 and 7-4 for available RS232 and RS485 cables.

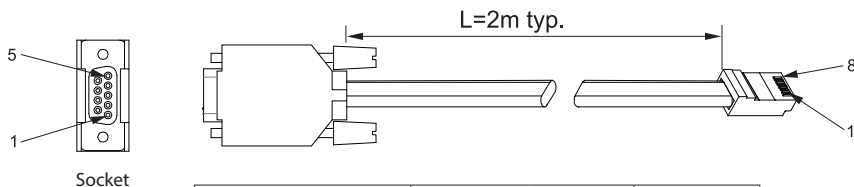

| DB-9 CONNECTOR | | 8 PIN CONNECTOR | | REMARKS |
|----------------|--------|-----------------|--------|---------|
| PIN NO. | NAME | PIN NO. | NAME | |
| HOUSING | SHIELD | HOUSING | SHIELD | |
| 2 | RX | 7 | TX | TWISTED |
| 3 | TX | 8 | RX | PAIR |
| 5 | SG | 1 | SG | |

Fig.7-3: RS232 cable with DB9 connector

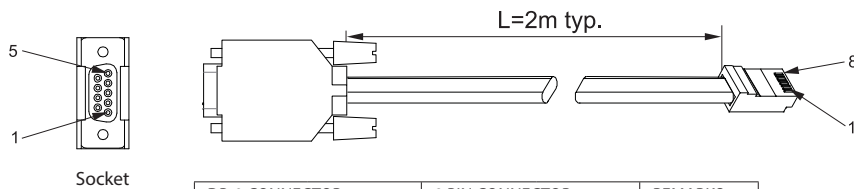

| DB-9 CONNECTOR | | 8 PIN CONNECTOR | | REMARKS |
|----------------|--------|-----------------|--------|---------|
| PIN NO. | NAME | PIN NO. | NAME | |
| HOUSING | SHIELD | HOUSING | SHIELD | |
| 9 | TXD- | 6 | RXD- | TWISTED |
| 8 | TXD+ | 3 | RXD+ | PAIR |
| 1 | SG | 1 | SG | |
| 5 | RXD- | 5 | TXD- | TWISTED |
| 4 | RXD+ | 4 | TXD+ | PAIR |

Fig.7-4: RS485 cable with DB9 connector

7.5 Rear Panel USB Connector

A standard USB Series B device connector is located on Rear panel for USB control. Refer to Fig.7-5 and Table 7-2.

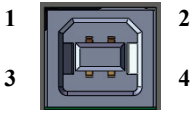

| Pin | Designator | Description |
|-----|------------|---------------|
| 1 | VBUS | +5 VDC |
| 2 | D- | Data - |
| 3 | D+ | Data + |
| 4 | GND | Interface com |

Fig.7-5: USB Connector

Table 7-2: USB connector pin out

7.5.1 USB Getting Started

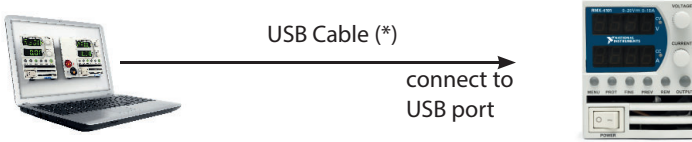

The following steps will help you quickly get started connecting your USB-enabled instrument to the Universal Serial Bus (USB):

1. Verify AC switch is OFF.
2. Connect RMX-410x to the USB port on the computer.
3. Turn AC switch ON.
4. Download and install the RMX-410x drivers from ni.com/downloads.

NOTE:

- * Do not connect or disconnect the USB cable when the PS is operating.
- * In case of USB Communication loss following steps should be applied:
 1. Turn AC switch OFF
 2. Close RMX-410x COM port
 3. Turn AC switch ON
 4. Open RMX-410x COM port

7.6 Multi Power Supply Connection to RS232, RS485, LAN, or USB

A Daisy-chain configuration of up to 31 units can be connected to RS232, RS485, LAN, or USB. The first unit connects to the controller via RS232, RS485, LAN, or USB and other units are connected with a RS485 bus. The user must set all slave power supplies to a unique address. No two power supplies may have the same address.

1. First unit connection: Select communication Interface. Refer to section 7.2.3.
2. Other unit connections: The other units on the bus are connected via their RS485 interface. Refer to Figures 7-6 and 7-7 for typical connections.
3. Using the Linking cable supplied with each unit (Refer to Fig.7-8), connect each unit OUT connector to the next unit IN connector.

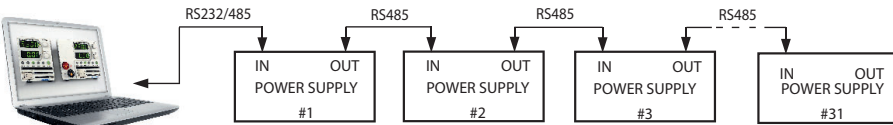

Fig.7-6: Multi power supplies RS232/485 connection

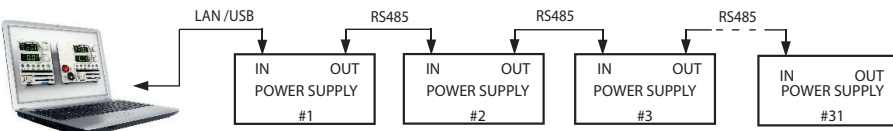
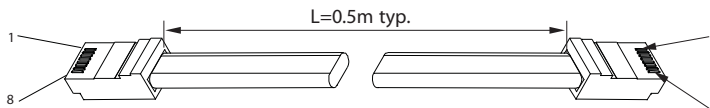

Fig.7-7: Multi power supplies LAN/USB connection

NOTES:

It is recommended when using ten or more power supplies in Daisy-chain system to connect 120Ω resistive termination at the last unit's RS-485 out connector
 120Ω, 0.5W between TXD+ and TXD-.
 120Ω, 0.5W between RXD+ and RXD-.



| 8 PIN CONNECTOR (IN) | | 8 PIN CONNECTOR (OUT) | |
|----------------------|--------|-----------------------|--------|
| PIN NO. | NAME | PIN NO. | NAME |
| HOUSING | SHIELD | HOUSING | SHIELD |
| 1 | SG | 1 | SG |
| 6 | TXD- | 6 | RXD- |
| 3 | TXD+ | 3 | RXD+ |
| 5 | RXD- | 5 | TXD- |
| 4 | RXD+ | 4 | TXD+ |

Fig.7-8: Serial link cable with RJ-45 shielded connectors

7.7 GEN Protocol (GEN series communication language)

NOTE:

The address (ADR n) command must return an "OK" response before any other commands are accepted.

7.7.1 Data Format

Serial data format is 8 bit, one start bit and one stop bit. No parity bit.

7.7.2 End of Message

The end of message is the Carriage Return character (ASCII 13, 0x0D). The power supply ignores the Line Feed (ASCII 10, 0x0A) character.

7.7.3 Command Repeat

The backslash character "\" will cause the last command to be repeated.

7.7.4 Checksum

The user may optionally add a checksum to the end of the command. The checksum is "\$" followed by two hex characters. If a command or a query has checksum, the response will also have one. There is no CR between the command string and the "\$" sign. Example: STT?\$3A STAT?\$7B

7.7.5 Acknowledge

The power supply acknowledges received commands by returning "OK" message. If an error is detected, the power supply will return an error message. The rules for checksum also apply to the acknowledge feature.

7.7.6 Backspace

The backspace character (ASCII 8) clears the last character sent to the power supply.

7.7.7 Error Messages

The power supply will return error messages for illegal commands and illegal programming parameters. Refer to Table 7-3 for programming error messages and Table 7-4 for command error messages.



| Error Code | Description |
|------------|---|
| E01 | Returned when program voltage (PV) is programmed above acceptable range. Example: PV above 95% of OVP setting. |
| E02 | Returned when programming output voltage below UVL setting. |
| E04 | Returned when OVP is programmed below acceptable range. Example: OVP value is less than 105% of voltage setting. |
| E06 | Returned when UVL value is programmed above the programmed output voltage. |
| E07 | Returned when programming the Output to ON during a latched fault shut down. |
| E08 | Cannot execute command via Advanced Slave Parallel mode. |

Table 7-3: Programming error messages

| Error Code | Description |
|------------|--------------------------|
| C01 | Illegal command or query |
| C02 | Missing parameter |
| C03 | Illegal parameter |
| C04 | Checksum error |
| C05 | Setting out of range |

Table 7-4: Commands error messages

7.8 GEN Command Set Description

7.8.1 General guides

1. Any command or argument may be in capital letters or small letters.
2. In commands with an argument, a space must appear between the command and the argument.
3. For any command that sets a numeric value, the value may be up to 12 characters long.
4. Carriage Return: If the CR character (ASCII 13) is received by itself, the power supply will respond with "OK" and CR.

7.8.2 Command Set Categories

The command set is divided into four categories as follows:

1. Identification Commands
2. Initialization Commands
3. Output Commands
4. Global Commands
5. Auxiliary Commands
6. Status Commands

7.8.3 Identification Commands

| | |
|-------|---|
| IDN? | Returns the power supply model identification as an ASCII string: Default: "RMXX-Y" (one comma, no spaces) X = rated output voltage Y = rated output current |
| REV? | Returns the software version as an ASCII string. Current rev: "REV:1.0" |
| SN? | Return power supply serial number. Up to 12 characters in any format. |
| DATE? | Returns date of last calibration. Format "yyyy/mm/dd". Example "2009/12/17" |

7.8.4 Initialization Commands

| Command | Description |
|---------|--|
| ADR n | ADR is followed by address which can be 1 to 31 and is used to access the power supply . |
| CLS | Clear status. Sets FEVE and SEVE registers to zero. |
| RST | Reset command. Brings the power supply to a safe and known state: Output voltage: zero, Remote: non-latched remote, Output current: zero, Auto-start: Off, Output: Off, OVP: maximum, FOLD: Off, UVL: zero The conditional registers (FLT and STAT) are updated, the other registers are not changed. |
| RMT | Sets the power supply to local or remote mode: 1. RMT 0 or RMT LOC, sets the power supply to Local mode. 2. RMT 1 or RMT REM, sets the unit to remote mode. 3. RMT 2 or RMT LLO, sets the unit to Local Lockout mode (latched remote mode). |
| RMT? | Returns the Remote mode setting: 1. "LOC"- The unit is in Local mode. 2. "REM"- The unit is in Remote mode. 3. "LLO"- The unit is in Local Lockout (latched remote) mode. |
| \ | Repeat last command. If \<CR> is received, the power supply will repeat the last command. |

7.8.5 Output Commands

| Command | Description |
|----------------------|--|
| PV n | Sets the output voltage value in Volts. The range of voltage value is described in Table 7-5. The maximum number of characters is 12. See the following examples for PV n format: PV 12, PV 012, PV 12.0, PV 012.00, etc... |
| PV? | Reads the output voltage setting. Returns 6 digit string. |
| MV? | Reads the actual output voltage. Return 6 digit string. Example: 60VDC supply sends 01.150, 15.012, 50.000, etc... |
| PC n (See Note 1) | Sets the output current value in Amperes. The range of current values are described in Tables 7-6... 7-9. The maximum number of characters is 12. See the following examples for PC n format: PC 10, PC 10.0, PC 010.00, etc... |
| PC? | Reads the output current setting. Returns 6 digit string. |
| MC? (See Note 2) | Reads the actual output current. Returns 6 digit string. Example: 72A supply sends 72.000, 20.140, 04.120, etc... |
| DVC? | Display Voltage and Current data. Data will be returned as a string of ASCII characters. A comma will separate the different fields. The fields, in order, are: Measured Voltage, Programmed Voltage, Measured Current, Programmed Current, Over Voltage Set point and Under Voltage Set Point. Example: 60V-10A supply sends: 60.0000, 60.0000, 05.0000, 05.0000. 66.00.00.00 |

| Command | Description |
|---------|--|
| OUT n | Turns the output to ON or OFF. Recover from Safe-Start, OVP or FLD fault. OUT 1 (or OUT ON)-Turn On. |
| OUT? | Returns the output On/Off status string. ON- output on. OFF- output off. |
| FLD n | Sets the Foldback protection to ON or OFF. FLD 1 (or FOLD ON) - Arms the Foldback protection. FLD 0 (or FOLD OFF)- Cancels the Foldback protection. When the Foldback protection has been activated, OUT 1 command will release the protection and re-arm it, while FLD 0 will cancel the protection. |
| FLD? | Returns the Foldback protection status string: "ON"- Foldback is armed, "OFF"- Foldback is canceled. |
| FBD nn | Add (nn x 0.1) seconds to the Fold Back Delay. This delay is in addition to the standard delay. The range of nn is 0 to 255. The value is stored in eeprom at AC power and recovered at AC power up. |
| FBD? | Supply returns the value of the added Fold Back Delay. |
| FBDRST | Reset the added Fold Back Delay to zero. |
| OVP n | Sets the OVP level. The OVP setting range is given in Table 7-9. The number of characters after OVP is up to 12. The minimum setting level is approx. 105% of the set output voltage, or the value in Table 7-9, whichever is higher. Attempting to program the OVP below this level will result in execution error response ("E04"). The OVP setting stays unchanged. |
| OVP? | Returns the setting "n" where "n" is the exact string in the user's "OVP n". When in Local mode, returns the last setting from the front panel in a 4 digit string. |
| OVM | Sets OVP level to the maximum level. Refer to Table 7-9. |
| UV? | Returns the under voltage mode UVP or UVL. |
| UVL n | Sets Under Voltage Limit. Maximum value of "n" is 5% below PV setting, but returns "E06" if higher. Refer to Table 7-10 for UVL programming range. |
| UVL? | Returns the setting "n" where "n" is the exact string in the user's "UVL n". When in Local mode, returns the last setting from the front panel in a 4 digit string. When UVP is activated, returns the setting |
| UVP n | Sets Under Voltage Protection. Maximum value of "n" is 5% below PV setting, but returns "E06" if higher. Refer to Table 7-10 for UVP programming range. |
| UVP? | Returns the setting "n" where "n" is the exact string in the user's "UVP n". When in Local mode, returns the last setting from the front panel in a 4 digit string. |
| AST n | Sets the auto-restart mode to ON or OFF. AST 1 (or AST ON)- Auto restart on. AST 0 (or AST OFF)- Auto restart off. |
| AST? | Returns the string auto-restart mode status. |
| SAV n | Saves present settings to specified location in memory (n=1...4). |
| RCL n | Recalls saved settings from specified location in memory (n=1...4). |
| MODE? | Returns the power supply operation mode. When the power supply is On (OUT 1) it will return "CV" or "CC". When the power supply is OFF (OUT 0) it will return "OFF". |
| PMS n | Sets the Master/Slave parallel operation mode of the power supply. n=H1...H6 (Master), n=SL (Basic Mode Slave), n=ADSL (Advanced Mode Slave). (Refer to tables 5-2, 5-2.1). |
| PMS? | Returns the Master/Slave setting. Master: H1...H6, Slave (Basic mode): S, Slave (Advanced mode): AD |

NOTES:

1. In Advanced Parallel mode (Refer to Sec. 5.5.3), "n" is the total system current.
2. In Advanced Parallel mode, "MC?" returns the Master unit current multiplied by the number of Slave units.
3. UVL? will return "C01" if UVP is activated and vice versa.
4. No command execution in Advance slave mode.

7.8.6 Global Output Commands

General

Global commands can be received by all power supplies connected to the BUS, without individual address commands. All power supplies will execute the command immediately. There is no acknowledgment back to the PC when using global commands. A delay must be set of 20msec after each global command. Error messages are not reported back to the issuing PC.

| | |
|--------|---|
| GRST | Reset. Brings the Power Supply to a safe and known state: Output voltage: 0V, output current: 0A, OUT: Off, Remote: RMT 1, AST: Off, OVP:Max, UVL:0V. The conditional register (FLT and STAT) are updated. Other registers are not changed. Non-Latching faults (FoldBack, OVP, SO, UVP) are cleared, OUT fault stays. |
| GPV n | Sets the output voltage value in volts. The range of voltage values is shown in Table 7-5. 'n' may be up to 12 char plus dec. pt |
| GPC n | Program the output current value in amperes. The range of current values is shown in Tables 7-6, 7-7 and 7-8. 'n' may be up to 12 char plus dec. pt |
| GOUT | Turns the output to ON or OFF: "OUT 1/ON" = turn on "OUT 0/OFF" = turn off, clears CV and CC bits in the Status Condition (STAT). OUT ON will respond with "E07" if the output cannot be turned on because of a latching fault (OTP, AC, ENA, SO) shutdown. |
| GSAV n | Saves present settings to specified location in memory (n=1...4). Same settings as power-down last settings listed in table 5-7. |
| GRCL n | Recall saved settings from specified location in memory (n=1...4). |

| Model Rated Output Voltage (V) | Minimum (V) | Maximum (V) |
|--------------------------------|-------------|-------------|
| 20 | 00.0000 | 20.0000 |
| 36 | 00.0000 | 36.0000 |
| 60 | 00.0000 | 60.0000 |
| 100 | 000.000 | 100.000 |

Table 7-5: Voltage programming range and communication response format

NOTE:

The power supply can accept values higher by 5% than the table values, however it is not recommended to program the power supply over the rated values.

| Model | Minimum (A) | Maximum (A) |
|--------|-------------|-------------|
| 20-10 | 00.0000 | 10.0000 |
| 36-6 | 0.00000 | 6.00000 |
| 60-3.5 | 0.00000 | 3.50000 |
| 100-2 | 0.00000 | 2.00000 |

Table 7-6: RMX-4101 models Current programming range and communication response format

| Model | Minimum (A) | Maximum (A) |
|-------|-------------|-------------|
| 20-20 | 00.0000 | 20.0000 |
| 36-12 | 00.0000 | 12.0000 |
| 60-7 | 0.00000 | 7.00000 |
| 100-4 | 0.00000 | 4.00000 |

Table 7-7: RMX-4102 models Current programming range and communication response format

| Model | Minimum (A) | Maximum (A) |
|-------|-------------|-------------|
| 20-40 | 00.0000 | 40.0000 |
| 36-24 | 00.0000 | 24.0000 |
| 60-14 | 00.0000 | 14.0000 |
| 100-8 | 00.0000 | 8.00000 |

Table 7-8: RMX-4104 models Current programming range and communication response format

NOTE:

The power supply can accept values higher by 5% than the table values, however it is not recommended to program the power supply over the rated values.

| Model Rated Output Voltage (V) | Minimum (V) | Maximum (V) |
|--------------------------------|-------------|-------------|
| 20 | 1.0 | 24.0 |
| 36 | 2.0 | 40.0 |
| 60 | 5.0 | 66.0 |
| 100 | 5.0 | 110 |

Table 7-9: OVP programming range

| Model Rated Output Voltage (V) | Minimum (V) | Maximum (V) |
|--------------------------------|-------------|-------------|
| 20 | 0 | 19.0 |
| 36 | 0 | 34.2 |
| 60 | 0 | 57.0 |
| 100 | 0 | 95.0 |

Table 7-10: UVL/UVP programming range

NOTE:

The UVP protection starts operating for values higher than 5% of Rated Output Voltage.

7.8.7 Auxiliary Commands

| | |
|-------|--|
| SOP | Sets SO polarity "SO 1/ON" –Positive (default), "SO 0/OFF"–Negative |
| SOP? | Returns the SO polarity |
| RIE | Remote Interlock (Inhibit) enable. "RIE 1/ON"–Enable, "RIE 0/OFF"–Disable" |
| RIE? | Returns Interlock enable status. "ON" –interlock enable, "OFF"–interlock disable. |
| FRST | Factory reset command. This command cover *RST command and additional settings. Sets factory default. This command breaks communication. Refer to Table 5-7. |
| MP? | Reads the actual output power. Returns 5 digit string. |
| REL1 | Set auxiliary programmed pin state J3-1. "REL1 1/ON"– High, REL1 0/OFF"– Low |
| REL1? | Response auxiliary programmed pin state J3-1. |
| REL2 | Set auxiliary programmed pin state J3-6, "REL2 1/ON"– High, REL2 0/OFF"– Low |
| REL2? | Response auxiliary programmed pin state J3-6 |

7.8.8 Status Commands

Refer to section 9.3.1, 9.3.2 for Register definitions.

| # | Command | Description |
|---|---------|---|
| 1 | STT? | Reads the complete power supply status. Returns ASCII characters representing the following data, separated by commas: MV<actual (measured) voltage> PC<programmed (set) current> PV<programmed (set) voltage> SR<status register, 4-digit hex> MC<actual (measured) current> FR<fault register, 4-digit hex> Example response: MV(45.2010),PV(45.0000),MC(4.32570),PC(4.50000),SR(0030),FR(0000) |
| 2 | FLT? | Reads Fault Conditional Register. Return 4-digit hex. |
| 3 | FENA | Set Fault Enable Register using 4-digit hex. |
| 4 | FENA? | Reads Fault Enable Register. Returns 4-digit hex. |
| 5 | FEVE? | Reads Fault Event Register. Returns 4-digit hex. Clears bits of Fault Event Register. |
| 6 | STAT? | Reads Status Conditional Register. Returns 4-digit hex. |
| 7 | SENA | Sets Status Enable Register using 4-digit hex. |
| 8 | SENA? | Reads Status Enable Register. Returns 4-digit hex. |
| 9 | SEVE? | Reads Status Event register. Returns 4-digit hex. Clears bits of Status Event register. |

7.9 Serial Communication Test Set-Up

Basic set-up to test serial communication operation.

1. **Equipment:** PC with Windows Hyper Terminal, private edition, software installed, RMX-410x power supply, RS232 cable.
2. **PC set-up:**
 - 2.1 Open Hyper Terminal.....New Connection.
 - 2.2 Enter a name
 - 2.3 Connect to.....Direct to Com1 or Com 2
 - 2.4 Configure port properties:

| | |
|-----------------------|------|
| Bits per second | 9600 |
| Data bits | 8 |
| Parity | None |
| Stop bits..... | 1 |
| Flow control..... | None |
 - 2.5 Open Properties in the program File.....Properties
 - 2.6 Setting: ASCII Set Up
Select Echo characters locally, select send line ends with line feed.
On some PC systems, pressing the number keypad "Enter" will distort displayed messages. Use the alphabetic "Enter" instead.
3. **Power supply set-up:**
 - 3.1 Connect the power supply to the PC using the RS232 cable.
 - 3.2 Set via the front panel: Baud Rate: 9600, Address: 06, RS232, GEN Language
4. **Communication test:**
 - 4.1 Model identification:
PC: write: ADR 06
Power supply response: "OK"
 - 4.2 Command test:
PC write: OUT 1
Power supply response: "OK"
PC write: PV n (for n values see Table 7-5)
Power supply response: "OK"
PC write: PC n (for n values see Tables 7-6, 7-7 and 7-8)
Power supply response: "OK"

The power supply should turn on and the display will indicate the output voltage and the actual output current.

7.10 SCPI Protocol

NOTE:

Selecting the power supply (INSTRument:NSElect <address>) is necessary before using any other command.

7.10.1 Data Format

Serial data format is 8 bit, one start bit and one stop bit. No parity bit.

7.10.2 End of Message

End of message is the Carriage Return character (ASCII 13) and the Line Feed (ASCII 10) character.

7.10.3 End of Command

End of command is Carriage Return character (ASCII 13) and/or the Line Feed (ASCII 10) character.

7.10.4 Checksum

The user may optionally add a checksum to the end of the command. The checksum is "\$" followed by two hex characters. If a command or a query has checksum, the response will also have one. There is no CR between the command string and the "\$" sign.

7.10.5 SCPI Requirements

The power supply conforms to the following SCPI requirements:

1. SCPI common commands.
2. SCPI Command Tree.
3. Subsystem commands.
4. The ROOT level.
5. The power supply is powered On
6. A device clear (DCL) is sent to the power supply
7. The SCPI interface encounters a root specifier (:)
8. Questionable Status Register (QSR), Condition, Event, Enable
9. Operation Status Register (OSR), Condition, Event, Enable
10. Status Byte Register (SBR)
11. Standard Event Status Register (SESR)
12. Using the MIN and MAX Parameters.
13. Suffix and Multipliers.
14. Boolean data. 1 | 0 or ON | OFF

7.10.6 SCPI Command Hierarchy

SCPI is an ASCII-based command language designed for use in test and measurement equipment. The command structure is organized around common roots, or nodes, which are the building blocks of SCPI subsystems. An example of a common root is OUTPut, and some of the commands that reside in the OUTPut subsystem are:

OUTPut

```

[:STATe]<bool>
:PON
      [:STATe]<bool>
:PROTection
      :CLEar
      :FOLDback
      [:MODE]

```

A colon (:) is used to separate a command keyword from a lower-level keyword.

7.10.7 Header

Headers are instructions recognized by the power supply. Headers (which are sometimes known as "keywords") may be either in long or short form.

| | |
|------------|---|
| Long form | The header is completely spelled out, such as VOLTAGE, STATUS, and DELAY |
| Short form | The header has only the first three or four letters, such as VOLT, STAT, and DEL. |

The SCPI interface is not sensitive to case. It will recognize any case mixture, such as TRIGGER, Trigger, TRIGger. Short form headers result in faster program execution.

7.10.8 Data Formats

| Data Formats | Description |
|--------------|---|
| <NR1> | Digits with an implied decimal point assumed at the right of the least-significant digit. Examples: 256 |
| <NR2> | Digits with an explicit decimal point. Example: .0253 |
| <NR3> | Digits with an explicit decimal point and an exponent. Example: 2.73E+2 |
| <NRF> | Extended format that includes <NR1>, <NR2> and <NR3>. Examples: 273 273.1 2.73E2 |
| <NRF+> | Expanded decimal format that includes <NRF> and MIN MAX. Examples: 273,273.1, 2.73E2, MAX. MIN and MAX are the minimum and maximum limit values that are implicit in the range specification for the parameter. |
| <Bool> | Boolean Data. Example: 0 1 or ON OFF |

7.10.9 Character Data

| | |
|-------|---|
| <CRD> | Character Response Data. Permits the return of character strings. |
|-------|---|

7.10.10 Commands Notes

- Expressions enclosed in square brackets, [], are optional and entered without the [or].
- Expressions enclosed in greater than/less than, < >, are programming values and entered without the < or >.
- The expression <SP> represents a one character ASCII Space.
- In all commands upper case characters can be interchanged with lower case characters.

7.11 SCPI Common Commands

Common commands begin with an * and consist of three letters (command) or three letters and a ? (query). Common commands are defined by the IEEE 488.2 standard to perform some common interface functions.

*CLS

Clear Status command. Clears the entire status structure.

NOTE:

Execution time for this command 150mS

| | |
|------------------|--------------|
| Meaning and Type | Clear Status |
| Command Syntax | *CLS |
| Parameters | None |
| Query Syntax | None |

*ESE

Standard Event Status Enable command. Modifies the contents of the Event Status Enable Register.

| Meaning and Type | Event Status Enable | Device Status |
|---------------------|---------------------|---------------|
| Command Syntax | *ESE <NRf> | |
| Parameters | 0 to 255 | |
| Query Syntax | *ESE? | |
| Returned Parameters | <NR1> 3digits | |

| Bit Position | 7 | 6 | 5 | 4 | 3 | 2 | 1 | 0 |
|--------------|-----|----|-----|-----|-----|-----|---|-----|
| Bit Name | PON | 0 | CME | EXE | DDE | QYE | 0 | OPC |
| Bit Weight | 128 | 64 | 32 | 16 | 8 | 4 | 2 | 1 |

CME = Command error; DDE = Device-dependent error; EXE = Execution error; OPC = Operation, complete; PON Power-on; QYE = Query error

*ESR?

Standard Event Status Register query. Returns the contents of the Event Status Register.

| Meaning and Type | Event Status | Device Status |
|---------------------|-----------------------------------|---------------|
| Query Syntax | *ESR? | |
| Returned Parameters | 0 to 255 (Register Decimal value) | |

*IDN?

Identification query. Returns an identification string in the following format: 'Manufacturer, Model, Serial number, Firmware level'.

| Meaning and Type | Identification System Interface | |
|---------------------|---|---|
| Query Syntax | *IDN? | |
| Returned Parameters | Field | Information |
| | National Instruments | Manufacturer |
| | RMX | Model |
| | <Vrating>-<Irating> | Model ratings |
| | 25B1234 | Serial number, typically 7 alpha-numeric characters |
| | 3.0-C1 | Revisions, <Main firmware>-<LAN/IEEE firmware> |
| Example | National Instruments,RMX20-30,25B1234, 1.0-C1 | |

*OPC

Operation Complete command. Sets the Operation Complete bit in the Standard Event Status Register if all commands and queries are completed.

| Meaning and Type | Operation Complete | Device Status |
|------------------|--------------------|---------------|
| Command Syntax | *OPC | |
| Parameters | None | |

*OPC?

Operation Complete query. Returns ASCII '1' as soon as all commands and queries are completed.

| Meaning and Type | Operation Complete | Device Status |
|------------------|---|---------------|
| Query Syntax | *OPC? | |
| Parameters | <NR1> ASCII 1 is placed in the Output Queue when the power supply has completed operations. | |

*OPT?

The options (OPT) query returns a comma-separated list of all of the instrument options currently installed on the signal generator.

| Parameter | Option |
|-----------|--------|
| 0 | NONE |
| 1 | IEEE |
| 2 | LAN |
| 3 | BOTH |

Query Syntax *OPT?
 Returned Parameters <CRD>

*PSC

The Power-On Status Clear (PSC) command controls the automatic power-on clearing of the Service Request Enable Register, the Standard Event Status Enable Register, and device-specific event enable registers.

- ON(1) - This choice enables the power-on clearing of the listed registers.
- OFF(0) - This choice disables the clearing of the listed registers and they retain their status when a power-on condition occurs.

| Meaning and Type | Power-on Status Clear Device Initialization |
|---------------------|---|
| Command Syntax | *PSC <bool> |
| Parameters | 0 1 OFF ON |
| Example | *PSC 0 *PSC 1 |
| Query Syntax | *PSC? |
| Returned Parameters | <NR1> 0 1 |

*RCL n

Restores the power supply to a state previously stored in memory by *SAV command. Refer to Table 5-7.

| | |
|----------------|------------|
| Command Syntax | *RCL <NR1> |
| Parameters | 1 to 4 |
| Example | *RCL 3 |

*RST

This command resets the power supply to a defined state as shown in Table 5-7. *RST also forces an ABORT command.

| | |
|----------------|------|
| Command Syntax | *RST |
| Parameters | None |

*SAV n

The SAV command saves all applied configuration setting. Refer to Table 5-7.

| | |
|----------------|------------|
| Command Syntax | *SAV <NR1> |
| Parameters | 1 to 4 |
| Query Syntax | None |

*SRE

Service Request Enable command. Modifies the contents of the Service Request Enable Register.

| Meaning and Type | Service Request Enable Device Interface |
|---------------------|---|
| Command Syntax | *SRE <NRf> |
| Parameters | 0 to 255 |
| Default Value | See *PSC |
| Example | *SRE 20 |
| Query Syntax | *SRE? |
| Returned Parameters | <NR1> (Register binary value) 3digits |

*STB?

Status Byte query. Returns the contents of the Status Byte Register.

| | |
|---------------------|-------------------------------|
| Meaning and Type | Status Byte Device Status |
| Query Syntax | *STB? |
| Returned Parameters | <NR1> (Register binary value) |

| | | | | | | | | |
|---|------|--------------|-----|-----|------|---|---|---|
| Bit Position | 7 | 6 | 5 | 4 | 3 | 2 | 1 | 0 |
| Condition | OPER | MSS (RQS) | ESB | MAV | QUES | 0 | 0 | 0 |
| Bit Weight | 128 | 64 | 32 | 16 | 8 | 4 | 2 | 1 |
| ESB = Event status byte summary; MAV = Message available | | | | | | | | |
| MSS = Master status summary; OPER = Operation status summary; | | | | | | | | |
| QUES = Questionable status summary; RQS = Request for service | | | | | | | | |

Table 7-11: Bit Configuration of Status Byte Register

*TRG

The Trigger command starts the waveform when the trigger source is set to BUS.

| | | |
|------------------|---------|----------------|
| Meaning and Type | Trigger | Device Trigger |
| Command Syntax | *TRG | |
| Parameters | None | |
| Query Syntax | None | |

ABORt

Resets the trigger system and places the power supply in an IDLE state without waiting for the completion of the trigger cycle.

| | |
|----------------|-------|
| Command Syntax | ABORt |
| Parameters | None |
| Example | ABOR |
| Query Syntax | None |

7.12 SCPI Subsystem Commands

Subsystem commands are specific to power supply functions. They can be a single command or a group of commands. Groups are comprised of commands that extend one or more levels below the root.

Commands followed by a question mark (?) take only the query form. Except as noted in the syntax descriptions, all other commands take both the command and query form.

7.12.1 Output Subsystem

OUTPut

This command enables or disables the power supply output. When output is turned off, voltage display shows "OFF".

| | |
|---------------------|-----------------------|
| SCPI Command Syntax | OUTPut[:STATe] <bool> |
| GEN Command Syntax | OUT <bool> |
| Parameters | 0 OFF 1 ON |
| *RST Value | OFF |
| Examples | OUTP 1 OUTP:STAT ON |
| Query Syntax | OUTPut[:STATe]? |
| Returned Parameters | 0 1 |

OUTPut:PON[:STATe]

- **AUTO** - The power supply output will return to its previous value when the latching fault condition is removed or to the stored value after AC recycle.
- **SAFE** - The power supply output will remain Off after the fault condition is removed or after AC recycle.

| | |
|---------------------|---------------------------|
| SCPI Command Syntax | OUTPut:PON[:STATe] <bool> |
| GEN Command Syntax | AST <bool> |
| Parameters | 0 OFF 1 ON |
| *RST Value | OFF |
| Examples | OUTPut:PON 1 |
| Query Syntax | OUTPut:PON[:STATe]? |
| Returned Parameters | 0 1 |

OUTPut:PROTection:CLEar

This command clears the latch that disables the output when an over voltage (OVP), under voltage (UVP), or foldback (FOLD) fault condition is detected. All conditions that generate a fault must be removed before the latch can be cleared. The output is then restored to the state before the fault condition occurred.

| | |
|---------------------|-------------------------|
| SCPI Command Syntax | OUTPut:PROTection:CLEar |
| GEN Command Syntax | None |
| Parameters | None |

OUTPut:PROTection:FOLDback

Foldback mode is used to disable the output when a transition is made between the operation modes. The power supply will turn off the output after a specified delay if the power supply makes transition into CV mode or into CC mode. This feature is particularly useful for protecting current or voltage sensitive loads.

| | |
|---------------------|-----------------------------------|
| SCPI Command Syntax | OUTPut:PROT:FOLDback[:MODE] <CRD> |
| GEN Command Syntax | FLD <CRD> |
| Parameters | OFF 0, CC 1, CV 2 . |
| *RST Value | OFF |
| Examples | OUTPut:PROT:FOLDback[:MODE] CC |
| Query Syntax | OUTPut:PROT:FOLDback[:MODE]? |
| Returned Parameters | <CRD> |

OUTPut:PROTection:DELAy

Sets the delay time between the programming of an output change that produces a CV or CC status condition. This command applies to UVP and Foldback functions.

| | |
|---------------------|---------------------------------|
| SCPI Command Syntax | OUTPut:PROTection:DELAy <NRf+> |
| GEN Command Syntax | FBD |
| Parameters | 0.1 to 25.5 MIN MAX (step 0.1s) |
| Unit | S (second) |
| *RST Value | 0mS |
| Examples | OUTPut:PROTection:DELAy 2E-1 |
| Query Syntax | OUTPut:PROTection:DELAy? |
| Returned Parameters | <NR3> |

OUTPut:ILC:MODE

Selects the mode of operation of the Remote Inhibit protection. In OFF mode the power supply ignores J3-4 (ILC) status.

| | |
|---------------------|-----------------------|
| SCPI Command Syntax | OUTPut:ILC:MODE <CRD> |
| GEN Command Syntax | RIE |
| Parameters | 0 OFF 1 ON |
| *RST Value | OFF |
| Examples | OUTPut:ILC:MODE ON |
| Query Syntax | OUTPut:ILC:MODE? |
| Returned Parameters | ON/OFF |

OUTPut:TTLTrg:MODE

Sets the operation of the Trigger Out signal to either OFF, Function Strobe or Trigger mode. Programming Mode NONE, FIX:

- In TRIG mode, trigger is generated when output status changes.
- In Function Strobe mode, an output pulse is generated automatically any time an output parameter such as output, voltage or current is programmed.

Programming modes LIST or WAVE:

- In TRIG mode, trigger is generated when LIST or WAVE is completed.
- In Function Strobe mode, an output pulse is generated automatically any time a step is completed.

The power supply Trigger Out signal is available at J3-3 connector on the rear panel.

| | |
|---------------------|--------------------------|
| SCPI Command Syntax | OUTPut:TTLTrg:MODE <CRD> |
| GEN Command Syntax | None |
| Parameters | TRIG FSTR OFF |
| *RST Value | OFF |
| Examples | OUTP:TTLT:MODE TRIG |
| Query Syntax | OUTP:TTLT:MODE? |
| Returned Parameters | <CRD> |

OUTPut:RELAy1(2):STATE

Sets pin J3-1 (1) and J3-6 (2) state. The ON parameter is according to low level.

| | |
|---------------------|---------------------------------|
| SCPI Command Syntax | OUTPut:RELAy1(2)[:STATE] <bool> |
| GEN Command Syntax | REL1(2) <bool> |
| Parameters | 0 OFF 1 ON |
| *RST Value | 1 |
| Examples | OUTP:REL1(2) 1 OUTP:REL1(2) ON |
| Query Syntax | OUTPut:RELAy1(2)[:STATE]? |
| Returned Parameters | 0 1 |

OUTPut:MODE?

Returns the power supply operation mode. When the power supply is On (OUT 1) it will return "CV" or "CC". When the power supply is OFF (OUT 0) it will return "OFF".

| | |
|---------------------|-----------------|
| SCPI Query Syntax | OUTPut:MODE? |
| GEN Query Syntax | MODE? |
| Returned Parameters | <CRD> CV CC OFF |

7.12.2 Instrument Subsystem

The subsystem programs one or more power supplies. <NR1> from 1 to 31.

INSTRument:COUPlE

| | |
|---------------------|-------------------------|
| SCPI Command Syntax | INSTRument:COUPlE <CRD> |
| GEN Command Syntax | None |
| Parameters | ALL NONE |

INSTRument:NSElect

| | |
|---------------------|--------------------------|
| SCPI Command Syntax | INSTRument:NSElect <NRf> |
| GEN Command Syntax | ADR n (single address) |
| Examples | INSTRument:NSElect 6 |
| Query Syntax | INSTRument:NSElect? |

7.12.3 Voltage Subsystem

VOLTage

Sets the output voltage value in Volts. The range of voltage values are described in Table 7-5. The maximum number of characters is 12.

| | |
|---------------------|---|
| SCPI Command Syntax | [SOURce]:VOLTage[:LEVel] [:IMMediate][:AMPLitude] <NRf+> |
| GEN Command Syntax | PV < NRf+> PV? |
| Default Suffix | V |
| *RST Value | 0 |
| Examples | :VOLT 500 MV VOLT:LEV 234.56789 |
| Query Syntax | [SOURce]:VOLTage[:LEVel][:IMMediate][:AMPLitude]? VOLTage? MAX VOLTage? MIN |
| Returned Parameters | <NR3> VOLT? returns the present programmed voltage level. VOLT? MAX and VOLT? MIN returns the maximum and minimum programmable voltage levels. |

VOLTage:MODE

This command selects FIX, LIST, WAVE subsystems control over the power supply output voltage.

| | |
|---------------------|------------------------------|
| SCPI Command Syntax | [SOURce]:VOLTage:MODE <CRD> |
| GEN Command Syntax | None |
| Parameters | NONE FIXed LIST WAVE |
| *RST Value | NONE |
| Examples | VOLT:MODE LIST VOLT:MODE FIX |
| Query Syntax | [SOURce]:VOLTage:MODE? |
| Returned Parameters | NONE FIX LIST WAVE |

NOTE:

VOLT:MODE LIST and WAVE is an implied ABORT command. WAVE mode cannot be programmed simultaneously for both Voltage and Current. Only the last sent command can be accepted as WAVE. Previous mode reverts to NONE.

VOLTage:PROTection:LEVel

Sets the OVP level. The OVP setting range is given in Table 7-9. The number of characters after OVP is up to 12. The minimum setting level is approx. 105% of the set output voltage, or the value in Table 7-9, whichever is higher.

| | |
|---------------------|--|
| SCPI Command Syntax | [SOURce]:VOLTage:PROTection:LEVel <nn.nn MAX> |
| GEN Command Syntax | OVP < NRf+> |
| Default Suffix | V |
| *RST Value | MAX |
| Examples | VOLT:PROT:LEV 2.5 |
| Query Syntax | [SOURce]:VOLTage:PROT:LEV? VOLT:PROT:LEVel? MIN VOLT:PROT:LEVel? MAX |
| Returned Parameters | <NR3> VOLT:PROT:LEV? returns presently programmed OVP level. VOLT:PROT:LEV? MAX and VOLT:PROT:LEV? MIN return the maximum and minimum programmable OVP levels. |

NOTE:

VOLT:PROT:LEV MIN set OVP level 5% above voltage set value

VOLTage:PROTection:LOW:STATe

Sets the under voltage protection (UVP) status of the power supply. If the UVP status selected, then the under voltage protection is enabled.

| | |
|---------------------|---|
| SCPI Command Syntax | [SOURce]:VOLTage:PROTection:LOW:STATe <CRD> |
| GEN Command Syntax | UVL < NRf+> , UVP < NRf+> |
| Parameters | UVL UVP |
| *RST Value | UVL |
| Examples | VOLT:PROT:LOW:STAT UVP |
| Query Syntax | [SOURce]:VOLTage:PROTection:LOW :STATe? |
| Returned Parameters | UVP UVL |

VOLTage:PROTection:LOW

Sets the under voltage protection (UVP) level of the power supply.

| | |
|---------------------|--|
| SCPI Command Syntax | [SOURce]:VOLTage:PROTection:LOW <NRf+> |
| GEN Command Syntax | UVL < NRf+> , UVP < NRf+> |
| Default Suffix | V |
| *RST Value | 0 |
| Examples | VOLT:PROT:LOW 2.5 VOLT:PROT:LOW MAX |
| Query Syntax | [SOURce]:VOLTage:PROTection:LOW [:LEVel]? VOLT:PROT:LOW? MIN; VOLT:PROT:LOW? MAX |
| Returned Parameters | <NR3> VOLT:PROT:LOW? returns presently programmed UVP level. VOLT:PROT:LOW? MAX and VOLT:PROT:LOW? MIN returns the maximum and minimum programmable UVP levels. |

NOTE:

VOLT:PROT:LOW MAX set UVP level maximum 5% below voltage value

VOLTage:TRIGger

Programs the pending triggered voltage level of the power supply. The pending triggered voltage level is a stored value that is transferred to the output terminals when a trigger occurs.

| | |
|---------------------|--|
| SCPI Command Syntax | [SOURce]:VOLTage[:LEVel]:TRIGger [:AMPLitude] <NRf+> |
| GEN Command Syntax | None |
| Default Suffix | V |
| Examples | VOLT:TRIG 1200 MV VOLT:LEV:TRIG 1.2 |
| Query Syntax | [SOURce]:VOLTage[:LEVel]:TRIGger [:AMPLitude]? |
| Returned Parameters | <NR3> VOLT:TRIG? returns the presently programmed voltage level. If the VOLT:TRIG level is not programmed, the default value is 0V. |

7.12.4 Current Subsystem

This subsystem programs the output current of the power supply.

CURRent

Sets the output current value in Amperes. The range of current values are described in Tables 7-6, 7-7 and 7-8. The maximum number of characters is 12.

| | |
|---------------------|---|
| SCPI Command Syntax | [SOURce]:CURRent[:LEVel][:IMMediate][:AMPLitude] <NRf+> |
| GEN Command Syntax | PC <NRf+> PC? |
| Default Suffix | A |
| *RST Value | 0 |
| Examples | CURR 500 MA CURR:LEV .5 |
| Query Syntax | [SOURce]:CURRent[:LEVel][:IMMediate][:AMPLitude]? [SOURce]:CURRent? MAX [SOURce]:CURRent? MIN |
| Returned Parameters | <NR3> CURR? returns the present programmed current level. CURR? MAX and CURR? MIN returns the maximum and minimum programmable current levels. |

CURRent:MODE

This command selects FIX, LIST, WAVE subsystems control over the power supply output current.

| | |
|---------------------|------------------------------|
| SCPI Command Syntax | [SOURce]:CURRent:MODE <CRD> |
| GEN Command Syntax | None |
| Parameters | NONE FIXed LIST WAVE |
| *RST Value | NONE |
| Examples | CURR:MODE LIST CURR:MODE FIX |
| Query Syntax | [SOURce]:CURRent:MODE? |
| Returned Parameters | NONE FIX LIST WAVE |

CURRent:TRIGger

Programs the pending triggered current level of the power supply. The pending triggered current level is a stored value that is transferred to the output terminals when a trigger occurs.

| | |
|---------------------|---|
| SCPI Command Syntax | [SOURce]:CURRent[:LEVel]:TRIGger[:AMPLitude] <NRf+> |
| GEN Command Syntax | None |
| Default Suffix | A |
| Examples | CURR:TRIG 3200 MA CURR:LEV:TRIG 3.2 |
| Query Syntax | [SOURce]:CURRent[LEVel]:TRIGger [:AMPLitude]? |
| Returned Parameters | <NR3> CURR:TRIG? returns the presently programmed triggered level. If no triggered level is programmed, the CURR level is returned. |

NOTE:

CURR:MODE LIST and WAVE are an implied ABORt command. Only the last sent command can be accepted as WAVE or LIST. Previous mode reverts to NONE.

7.12.5 Measure Subsystem

This subsystem reads the actual voltage and current. The power is a result of multiplying voltage and current measurements.

MEASure:CURRent?

Reads the measured output current. Returns a 6 digit string.

| | |
|---------------------|------------------|
| SCPI Command Syntax | MEASure:CURRent? |
| GEN Command Syntax | MC? |
| Parameters | None |
| Default Suffix | A |
| Returned Parameters | <NR3> |



MEASure:VOLTage?

Reads the measured output voltage. Returns a 6 digit string.

| | |
|---------------------|------------------|
| SCPI Command Syntax | MEASure:VOLTage? |
| GEN Command Syntax | MV? |
| Parameters | None |
| Default Suffix | V |
| Returned Parameters | <NR3> |

MEASure:POWer?

Reads the measured output power. Returns a 6 digit string.

| | |
|---------------------|----------------|
| SCPI Command Syntax | MEASure:POWer? |
| GEN Command Syntax | MP? |
| Parameters | None |
| Default Suffix | W |
| Returned Parameters | <NR3> |

7.12.6 DISPlay Subsystem

DISPlay:STATe

Turns front panel voltage and Current display toggle On or Off.

| | |
|---------------------|-------------------------------|
| SCPI Command Syntax | DISPlay[:WINDow]:STATe <bool> |
| GEN Command Syntax | none |
| Parameters | 0 OFF 1 ON |
| Examples | DISP:STAT 1 DISP:STAT OFF |
| Query Syntax | DISPlay[:WINDow]:STAT? |
| Returned Parameters | 0 1 |

DISPlay:FLASh

Makes front panel voltage and Current displays flash.

| | |
|---------------------|-------------------------------|
| SCPI Command Syntax | DISPlay[:WINDow]:FLASh <bool> |
| GEN Command Syntax | none |
| Parameters | 0 OFF 1 ON |
| Examples | DISP:FLASh 1 DISP:FLASh OFF |

7.12.7 INITiate Subsystem

INITiate

Enables the trigger subsystem. If a trigger circuit is not enabled, all trigger commands are ignored.

| | |
|---------------------|----------------------|
| SCPI Command Syntax | INITiate[:IMMEDIATE] |
| GEN Command Syntax | None |
| Parameters | None |
| Examples | INIT:IMM |
| Query Syntax | None |

INITiate:CONTinuous

- **INIT:CONT 0** - Enables the trigger subsystem only for a single trigger action. The subsystem must be enabled prior to each subsequent trigger action.
- **INIT:CONT 1** - Trigger system is continuously enabled and INIT is redundant.

| | |
|---------------------|----------------------------|
| SCPI Command Syntax | INITiate:CONTinuous <bool> |
| Parameters | 0 OFF 1 ON |
| Examples | INIT:CONT 1 INIT:CONT ON |
| Query Syntax | INITiate:CONTinuous? |
| Returned Parameters | 0 1 |

NOTE:

When power supply is in INIT:CONT ON mode, it's impossible to change any programming parameter. Display shows "Err". Send ABORT commands to allow parameter change.

7.12.8 LIST Subsystem

This subsystem receives parameters to create a step waveform of the output voltage or current.

NOTE:

All list subsystem commands (as well as CURR:MODE LIST and VOLT:MODE LIST) are implied ABORT commands.

LIST:COUNT

Sets the number of times that the list is executed before it is completed. The command accepts parameters in the range 1 through 9999, but any number greater than 9999 is interpreted as INFINITY. Use INF if you wish to execute a list indefinitely.

| | |
|---------------------|--|
| SCPI Command Syntax | [SOURce]:LIST:COUNT <NR1> |
| Parameters | 1 to 9999 INFINITY |
| *RST | 1 |
| Examples | LIST:COUN 3 LIST:COUN INF |
| Query Syntax | [SOURce]:LIST:COUNT? (if count>9999 the response is INF) |
| Returned Parameters | <NR1> |

LIST:CURRent

Specifies the output current points in a list. The current points are given in the command parameters, which are separated by commas.

| | |
|---------------------|---|
| SCPI Command Syntax | [SOURce]:LIST:CURRent <NRF+> {,<NRF+>} |
| Default Suffix | A |
| Examples | LIST:CURR 2.5,3.0,3.5 LIST:CURR MAX,2.5,MIN up to 12 parameters |
| Query Syntax | LIST:CURRent? |
| Returned Parameters | 2.5,3.0,3.5 |

LIST:LOAD

Loads from memory LIST type. Type voltage/current values, dwell values, STEP parameter and counter specified in stored numbers <1..4>

| | |
|---------------------|-------------------------|
| SCPI Command Syntax | [SOURce]LIST:LOAD <NR1> |
| Examples | LIST:LOAD 3 |

LIST:DWELI

Specifies the time interval that each value (point) of a list is to remain in effect.

| | |
|---------------------|--|
| SCPI Command Syntax | [SOURce]:LIST:DWELI <NRF+> {,<NRF+>} |
| Range | 0.001 to 129,600 seconds |
| Default Suffix | S |
| Examples | LIST:DWEL ,6,1.5,1.5,4 up to 12 parameters |
| Related Commands | CURR:MODE LIST:COUN LIST:CURR LIST:STEP LIST:VOLT VOLT:MODE |
| Query Syntax | LIST:DWEL? |
| Returned Parameters | ,6,1.5,1.5,4 |

LIST:STEP

Determines if a trigger causes a list to advance only to its next point or to sequence through all the points.

- **LIST:STEP AUTO** - When triggered, it creates waveforms consecutively, until the list is completed.
- **LIST:STEP ONCE** - When triggered, it executes one step from the list.

| | |
|---------------------|--------------------------|
| SCPI Command Syntax | [SOURce]:LIST:STEP <CRD> |
| Parameters | AUTO ONCE |
| *RST | AUTO |
| Examples | LIST:STEP ONCE |
| Query Syntax | [SOURce]:LIST:STEP? |
| Returned Parameters | AUTO ONCE |

LIST:VOLTage

Specifies the output voltage points in a list. The voltage points are given in the command parameters, which are separated by commas.

| | |
|---------------------|--|
| SCPI Command Syntax | [SOURce]:LIST:VOLTage <NRf+> {,<NRf+>} |
| Default Suffix | V |
| Examples | LIST:VOLT 2.0,2.5,3.0 LIST:VOLT MAX,2.5,MIN up to 12 parameters |
| Query Syntax | LIST:VOLT? |
| Returned Parameters | 2.0,2.5,3.0 |

LIST:STORe

Saves data under specified numbers <1..4> of the last LIST typed (voltage or/and current, dwell time, STEP parameter and counter).

| | |
|---------------------|--------------------------|
| SCPI Command Syntax | [SOURce]LIST:STORe <NR1> |
| Example | LIST:STORe 3 |

7.12.9 STATus Subsystem

Refer to Fig. 9-1 for more details.

STATus:OPERation:EVENT?

This query returns the value of the Event register. This is a read-only register that receives data from the Condition register according to Enable register setting. Reading the Event register clears it.

| | |
|---------------------|--------------------------------|
| SCPI Command Syntax | STATus:OPERation:EVENT? |
| GEN Command Syntax | SEVE? |
| Parameters | None |
| Returned Parameters | <NR1> (Register Value) decimal |
| Examples | STAT:OPER:EVEN? |

STATus:OPERation:CONDition?

Returns the value of the Condition register, which is a read-only register that holds the real-time (unlatched) operational status of the power supply.

| | |
|---------------------|--------------------------------|
| SCPI Command Syntax | STATus:OPERation:CONDition? |
| GEN Command Syntax | STAT? |
| Parameters | None |
| Returned Parameters | <NR1> (Register Value) decimal |
| Examples | STAT:OPER:COND? |



STATus:OPERation:ENABLE

Sets the value of the Enable register. This register is a mask for enabling specific bits from the Condition register to the Event register.

| | |
|---------------------|--------------------------------------|
| SCPI Command Syntax | STATus:OPERation:ENABLE <NRF> |
| GEN Command Syntax | SENA nnnn, SENA? |
| Parameters | 0...7FFF |
| Returned Parameters | <NR1> (Register Value) decimal |
| Default Value | 0 |
| Query Syntax | STATus:OPERation:ENABLE? |
| Examples | STAT:OPER:ENAB 1312 STAT:OPER:ENAB 1 |

STATus:QUESTionable[:EVENT]?

This query returns the value of the Event register. It is a read-only register that receives data from the Condition register according to Enable register setting. Reading the Event register clears it.

| | |
|---------------------|--------------------------------|
| SCPI Command Syntax | STATus:QUESTionable[:EVENT]? |
| GEN Command Syntax | FLT? |
| Parameters | None |
| Returned Parameters | <NR1> (Register Value) decimal |
| Examples | STAT:QUES:EVEN? |

STATus:QUESTionable:CONDition?

Returns the value of the Condition register, which is a read-only register that holds the real-time (unlatched) operational status of the power supply.

| | |
|---------------------|--------------------------------|
| SCPI Command Syntax | STATus:QUESTionable:CONDition? |
| GEN Command Syntax | FEVE? |
| Parameters | None |
| Returned Parameters | <NR1> (Register Value) decimal |
| Examples | STAT: QUES: COND? |

STATus:QUESTionable:ENABLE

Sets the value of the Enable register. This register is a mask for enabling specific bits from the Condition register to the Event register.

| | |
|---------------------|----------------------------------|
| SCPI Command Syntax | STATus:QUESTionable:ENABLE <NRF> |
| GEN Command Syntax | FENA nnnn |
| Parameters | 0 to 32727 |
| Returned Parameters | <NR1> (Register Value) decimal |
| Default Value | 0 |
| Query Syntax | STATus: QUESTionabl:ENABLE? |
| Examples | STAT:QUES:ENAB 18 |

7.12.10 SYSTem Subsystem

SYSTem:ERROr:ENABLe

Enables Error messages.

| | |
|---------------------|---------------------|
| SCPI Command Syntax | SYSTem:ERROr:ENABLe |
| GEN Command Syntax | None |
| Parameters | None |
| Returned Parameters | None |

SYSTem:ERROr?

Returns the next error number and corresponding error message in the power supply error queue. Works as FIFO. When no error exists 0, "No error" is returned.

| | |
|---------------------|---------------|
| SCPI Command Syntax | SYSTem:ERROr? |
| GEN Command Syntax | None |
| Parameters | None |
| Returned Parameters | <NR1>,<CRD> |
| Example | SYST:ERR? |

SYSTem:LANGUage

| | |
|---------------------|---------------------|
| SCPI Command Syntax | SYSTem:LANGUage GEN |
| GEN Command Syntax | None |
| Query Syntax | SYSTem:LANGUage? |
| Returned Parameters | SCPI |

SYSTem:REMOte

Sets the power supply to local or remote mode.

| | |
|---------------------|-----------------------------|
| SCPI Command Syntax | SYSTem:REMOte[:STAtE] <CRD> |
| GEN Command Syntax | RMT |
| Parameters | LOC/0 REM/1 LLO/2 |
| *RST Value | LOC |
| Example | SYST:REM REM |
| Query Syntax | SYST:REM? |
| Returned Parameters | LOC REM LLO |

SYSTem:VERSion?

| | |
|---------------------|-----------------|
| SCPI Command Syntax | SYSTem:VERSion? |
| GEN Command Syntax | REV? |
| Returned Parameters | Rev:<CRD> |
| Example | Rev:1.010 |

SYSTem:DATE?

| | |
|---------------------|------------------|
| SCPI Command Syntax | SYSTem:DATE? |
| GEN Command Syntax | DATE? |
| Query Syntax | SYSTem:DATE? |
| Returned Parameters | <CRD> yyyy/mm/dd |

SYSTem:PON:TIME?

Time measured from first power On.

| | |
|---------------------|------------------|
| SCPI Command Syntax | SYSTem:PON:TIME? |
| Parameters | Minute |
| Example | 6534 |
| Returned Parameters | <NR1> |

7.12.11 TRIGger Subsystem

NOTE:

The Trigger subsystem must be enabled from the Initiate subsystem or no triggering action will occur.

TRIGger

When the Trigger subsystem is enabled, TRIG generates an immediate trigger signal that bypasses selected TRIG:DEL.

| | |
|---------------------|------------------------------|
| SCPI Command Syntax | TRIGger[:START][:!IMMediate] |
| GEN Command Syntax | None |
| Parameters | None |

TRIGgger:DELay

Sets the time delay between the detection of an event on the specified trigger source and the start of any corresponding trigger action on the power supply output.

| | |
|---------------------|------------------------------|
| SCPI Command Syntax | TRIGger[:START]:DELay <NRf+> |
| GEN Command Syntax | None |
| Default Suffix | S |
| *RST Value | 0 |
| Examples | TRIG:DEL .25 TRIG:DEL MAX |
| Query Syntax | TRIGger[:START]:DELay? |
| Returned Parameters | <NR3> |

TRIGger:SOURce

Selects the power supply input trigger source as follows:

- **BUS (*TRG & TRIG) and Front Panel**
- **EXT Mainframe backplane Trigger IN PIN**

| | |
|---------------------|------------------------------|
| SCPI Command Syntax | TRIGger[:STArT]:SOURce <CRD> |
| GEN Command Syntax | None |
| Parameters | BUS EXTernal |
| *RST Value | EXTernal |
| Examples | TRIG: SOUR BUS |
| Query Syntax | TRIGger[:STArT]:SOURce? |
| Returned Parameters | BUS EXT |

7.12.12 WAVE Subsystem

This subsystem receives parameters to create a sloped waveform of the output voltage or current.

WAVE:COUNT

Sets the number of times that the list is executed before it is completed. The command accepts parameters in the range 1 through 9999. Any number greater than 9999 is interpreted as INFINITY. Use INF if you wish to execute a list indefinitely.

| | |
|---------------------|--|
| SCPI Command Syntax | [SOURce]:WAVE:COUNT <NRF+> |
| Parameters | 1 to 9999 INFINITY |
| *RST | 1 |
| Examples | WAVE:COUN 3 WAVE:COUN INF |
| Query Syntax | [SOURce]:WAVE:COUNT? (if count>9999 the response is INF) |
| Returned Parameters | <NR3> |

WAVE:CURREnt

This command specifies the output current points in a waveform list. The current points are given in the command parameters, which are separated by commas.

| | |
|---------------------|---|
| SCPI Command Syntax | [SOURce]:WAVE:CURREnt <NRF+> {,<NRF+>} |
| Default Suffix | A |
| Examples | WAVE:CURR 2.5,3.0,3.5 up to 12 parameters |
| Query Syntax | WAVE:CURR? |
| Returned Parameters | <NR3> |

WAVE:LOAD

Loads Voltage or Current, Time, STEP parameter and counter values to a specific location in the memory defined by numbers <1..4>.

| | |
|---------------------|-------------------------|
| SCPI Command Syntax | [SOURce]WAVE:LOAD <NR1> |
| Example | WAVE:LOAD 3 |
| Query Syntax | none |
| Returned Parameters | 1..4 |

WAVE:STEP

- **WAVE:STEP AUTO** - When triggered, creates waveforms consecutively, until the wave is completed.
- **WAVE:STEP ONCE** - When triggered, it executes one step from the list.

| | |
|---------------------|-------------------------|
| SCPI Command Syntax | [SOURce]WAVE:STEP <CRD> |
| Example | WAVE:STEP AUTO |
| Query Syntax | [SOURce]:WAVE:STEP? |
| Returned Parameters | AUTO ONCE |

WAVE:STORe

Stores Voltage or Current, Time, STEP parameter and counter values to specific location in the memory defined by numbers <1..4>.

| | |
|---------------------|-------------------------|
| SCPI Command Syntax | [SOURce]WAVE:STORe<NF1> |
| Example | WAVE:STORe 3 |

WAVE:TIME

Sets the slope time of the waveform.

| | |
|---------------------|---|
| SCPI Command Syntax | [SOURce]:WAVE:TIME <NRf1> {,<NRf1>} |
| Range | 0.001 to 129,600 seconds |
| Default Suffix | S |
| Examples | WAVE:TIME .6,1.5,1.5,.4 up to 12 parameters |
| Query Syntax | WAVE:TIME? |
| Returned Parameters | .6,1.5,1.5,.4 |

WAVE:VOLTage

Specifies the output voltage points in a waveform list.

| | |
|---------------------|---|
| SCPI Command Syntax | [SOURce]:WAVE:VOLTage <NRf+> {,<NRf+>} |
| Default Suffix | V |
| Examples | WAVE:VOLT 2.5,3.0,3.5 WAVE:VOLT MAX,2.5,MIN up to 12 parameters |
| Query Syntax | WAVE:VOLT? |
| Returned Parameters | MAX,2.5,MIN |

7.12.13 Global Subsystem

Global Commands General

- **Power supplies acting upon Global Commands need not be a currently addressed supply.**
- **All power supplies attached to the Interface must be capable of accepting Global Commands.**
- **No messages, OPC or Not Busy will be returned to the HOST PC after a Global Command has been issued. The Busy Bit of the Status Byte will be set to 0 after this command is issued.**
- **It will be the responsibility of the User Software to add a 20mS delay after each Global Command is issued and before any other command can be issued.**

Global Commands List

| Command Name | Description | SCPI Format | GEN Format | Result From Supply |
|---------------------------------------|-------------------------------------|-----------------------------------|------------|--------------------|
| Enable all Outputs | Output On to last V & I levels | GLOBAL:OUTPut:STATe 1 ON | GOUT 1 | None |
| Disable all Outputs | Turn outputs Off to zero V & I | GLOBAL:OUTPut:STATe 0 OFF | GOUT 0 | None |
| Program all Voltages | Set all power supply output voltage | GLOBAL:VOLTage:[AMPLitude] xxx.yy | GPV xxx.yy | None |
| Program all Currents | Set all power supply output current | GLOBAL:CURRent:[AMPLitude] xxx.yy | GPC xxx.yy | None |
| Save Settings of all power supplies | Same as *SAV n | GLOBAL:*SAV <NR1> | GSAV n | None |
| Recall Settings of all power supplies | Same as *RCL n | GLOBAL:*RCL <NR1> | GRCL n | None |
| Reset all supplies | Same as *RST | GLOBAL:*RST | GRST | None |

Table 7-12: Global Commands

7.13 Command Summary

Common Commands

| SCPI Command | Description | GEN Command |
|----------------|--|-------------|
| *CLS | Clear status | CLS |
| *ESE <NRf> | Standard event status enable | <NC> |
| *ESE? | Return standard event status enable | <NC> |
| *ESR? | Return event status register | <NC> |
| *IDN? | Return instrument identification string | IDN? |
| *OPC | Set "operation complete" bit in ESR | <NC> |
| *OPC? | Return a "1" when operation command complete | <NC> |
| *OPT? | Return option number | <NC> |
| *PSC {1 0} | Power - ON status enable (1) /disable (0) | <NC> |
| *PSC? | Power - ON status clear | <NC> |
| *RCL {1 2 3 4} | Recalls a saved instrument state | RCL |
| *RST | Reset | RST |
| *SAV {1 2 3 4} | Saves an instrument state | SAV |
| *SRE <NRf> | Set service request enable register | <NC> |
| *SRE? | Return service request enable register | <NC> |
| *STB? | Return status byte | <NC> |
| *TRG | Trigger | <NC> |

Subsystem Commands

| SCPI Command | Description | GEN Command |
|------------------------|--|-------------|
| ABORt | Aborts the triggered action | <NC> |
| DISPlay | | |
| [:WINDow]:STATe <bool> | Display ON/OFF | <NC> |
| [:WINDow]:FLASh <bool> | Display Flash | <NC> |
| GLOBal | | |
| :CURRent | | |
| :[AMPLitude] <NRF+> | Set the output current for all power supplies | GPC |
| :VOLTage | | |
| :[AMPLitude] <NRF+> | Set the output voltage for all power supplies | GPV |
| :OUTPut:STATe <bool> | Enables/disables the all power supplies output | GOUT |
| *RCL {1 2 3 4} | Recall setting for all power supplies | GRCL |
| *RST | Reset all power supplies | GRST |
| *SAV {1 2 3 4} | Save settings for all power supplies | GSAV |
| INITiate | | |
| [:IMMediate] | Trigger initiate | <NC> |
| :CONTinuous <bool> | Enable/disable continuously trigger | <NC> |
| INSTrument | | |
| :COUPlE ALL NONE | Couple for all RMX-410x power supplies | <NC> |
| :NSElect <NRF+> | Select the power supply for communication | ADR |
| MEASure | | |
| :CURRent[:DC]? | Returns the measured output current | MC? |
| :VOLTage[:DC]? | Returns the measured output voltage | MV? |
| :POWer[:DC]? | Returns the measured output power | MP? |
| OUTPut | | |
| [:STATe] <Bool> | Enables/disable the supply output | OUT[?] |
| :PON | | |
| [:STATe] <bool> | Programs the Power-ON state | AST[?] |
| :PROTection | | |
| :CLEar | Resets latched protection | |
| :FOLDback | | |
| [:MODE] OFF CC CV | Set operation protection mode | FLD[?] |
| :DElay <NRF+> | Set protection delay | FBD[?] |
| :ILC | | |
| :MODE <bool> | Enables/disable analog output ON/OFF control | RIE[?] |
| :TTLTrg | | |

| | | |
|--------------------------|--|-------------|
| :MODE OFF FSTR TRIG | Set output trigger mode | <NC> |
| :RElAy {1 2} | | |
| [:STATe] <bool> | Set control pins status | REL{1 2}[?] |
| :MODE? | Returns the operation mode CV/CC/OFF | MODE? |
| [SOURce] | | |
| :CURRent | | |
| [:LEVel] | | |
| [:IMMediate] | | |
| [:AMPLitude] <NRf+> | [:AMPLitude] <NRf+> Set the output current | PC[?] |
| :TRIGger <NRf+> | Set the triggered output current | <NC> |
| :MODE NONE FIX LIST WAVE | Select arbitrary trigger control mode | <NC> |
| :VOLTage | | |
| [:LEVel] | | |
| [:IMMediate] | | |
| [:AMPLitude] <NRf+> | Set the output voltage | PV[?] |
| :TRIGger <NRf+> | Set the triggered output voltage | <NC> |
| :PROTection | | |
| :LEVel <NRf+> | Set over-voltage protection level | OVP[?],OVM |
| :LOW | | |
| :STATe UVP UVL | Set under-voltage limit or protection mode | UVV[*] |
| [:LEVel] <NRf+> | Set under-voltage level | UVP,UVL |
| :MODE NONE FIX LIST WAVE | Select arbitrary control mode | <NC> |
| :LIST | | |
| :COUNT {0...9999,Inf} | Set number of time execution | <NC> |
| :CURRent <NRf+> | Set output current points | <NC> |
| :LOAD {1 2 3 4} | Load stored LIST program from memory | <NC> |
| :STEP ONCE AUTO | Set trigger depends execution step | <NC> |
| :STORe {1 2 3 4} | Store LIST program in memory | <NC> |
| :DWELl <NRf+> | Set time interval | <NC> |
| :VOLTage <NRf+> | Set output voltage points | <NC> |
| :WAVE | | |
| :COUNT {1...9999,Inf} | Set number of time execution | <NC> |
| :CURRent <NRf+> | Set output current points | <NC> |
| :LOAD {1 2 3 4} | Load stored WAVE program from memory | <NC> |
| :STEP ONCE AUTO | Set trigger depends execution step | <NC> |
| :STORe {1 2 3 4} | Store WAVE program in memory | <NC> |
| :TIME <NRf+> | Set slope time | <NC> |

| | | |
|----------------------|---|---------|
| :VOLTage <NRF+> | Set output voltage points | <NC> |
| STATus | | |
| :OPERation | | |
| [:EVENT]? | Returns the value of the Event register | SEVE? |
| :CONDition | Returns the value of the Condition register | STAT? |
| :ENABle <NRF+> | Enables specific bits in the Event register | SENA[?] |
| :QUESTionable | | |
| [:EVENT]? | Returns the value of the Event register | FEVE? |
| :CONDition | Returns the value of the Condition register | FLT? |
| :ENABle <NRF+> | Enables specific bits in the Event register | FENA[?] |
| SYSTem | | |
| :ERRor:ENABle | Enable error message | <NC> |
| :ERRor? | Read system error messages | <NC> |
| :LANGUage GEN | Set communication language | <NC> |
| :REMote | | |
| [:STATe] LOC REM LLO | Set the remote/local state | RMT[?] |
| :VERSion? | Returns software revision | REV? |
| :DATE? | Returns calibration date | DATE? |
| :PON | | |
| :TIME? | Response time from last reset | <NC> |
| TRIGger | | |
| [:START] | Run trigger | <NC> |
| :DELay <NRF+> | Set input trigger delay | <NC> |
| :SOURce EXTernal BUS | Set input trigger source | <NC> |
| <NC> | Display Voltage and Current data. Data | DVC? |
| <NC> | Reads the complete power supply status. | STT? |
| <NC> | Reset the added Fold Back Delay to zero. | FBDRST |
| <NC> | Sets the Master/Slave parallel operation mode | PMS[?] |
| <NC> | Sets SO signal polarity | SOP[?] |
| <NC> | Set factory default parameters | FRST |

NOTES:

- <NC> - "NO COMMAND" command/query don't exist.
- [?] – Command and query available (GEN command).
- (*) – command UVP or UVL set protection or limit mode and level

CHAPTER 8: ADVANCED FUNCTIONS

8.1 Introduction

This chapter describes the advanced functions of output programmable modes. There are three programmable modes: FIX, WAVE and LIST. The user can program the output transient state. The programmable modes are synchronized by input trigger (refer to section 8.5.1). According to the selected mode, the power supply activates the output trigger on J3-3 (refer to section 8.5.2).

8.2 FIX Mode

Output value is changed via input trigger. Refer to 7.12.3 VOLTage:TRIGger and 7.12.4 CURRent:TRIGger.

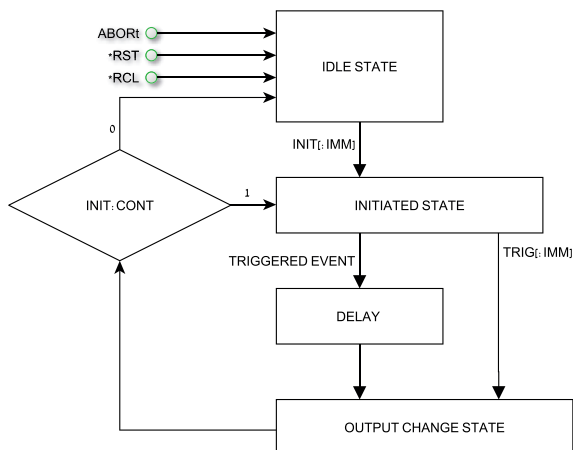

Fig.8-1: Simplified Models of FIX Mode

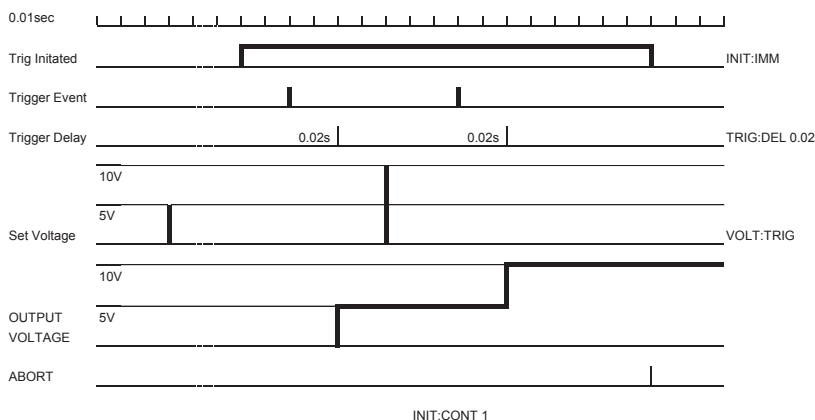

Fig.8-2: Fix Mode Sequence example

8.3 LIST Mode

Output change value in step determined by parameters in the LIST subsystem via input trigger. Refer to section 7.12.8

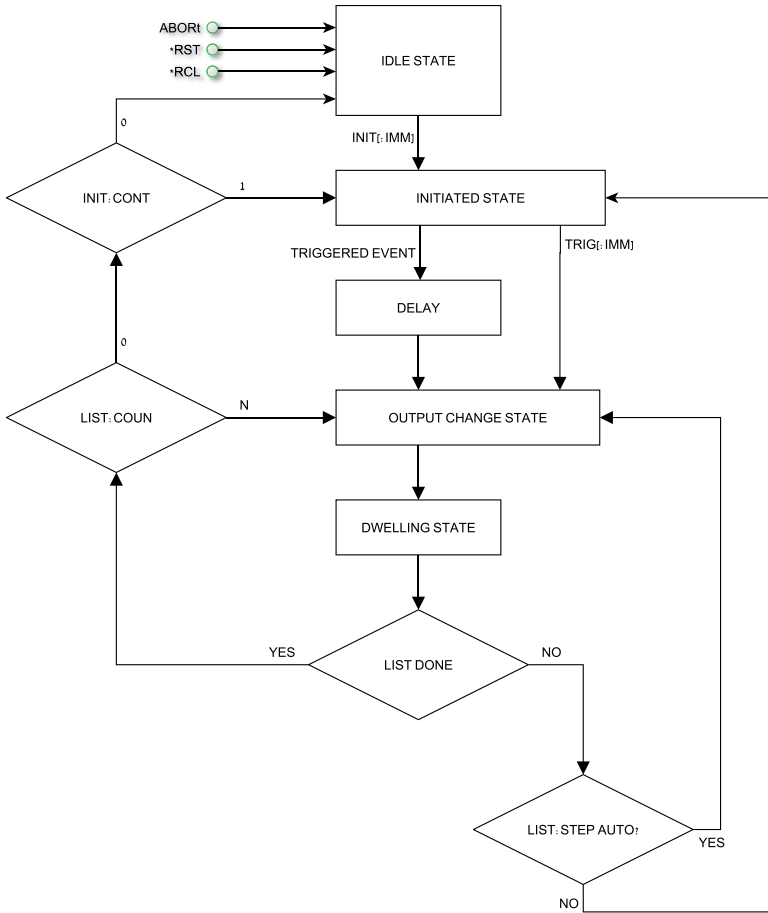

Fig.8-3: Simplified Models of LIST Mode

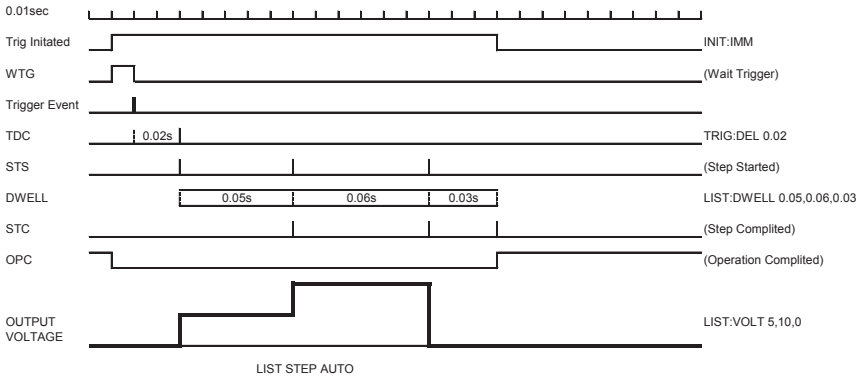

Fig.8-4: LIST Mode Sequence example

8.4 WAVE Mode

Output change value in slope determined by parameters in the WAVE subsystem via input trigger. Refer to section 7.12.12.

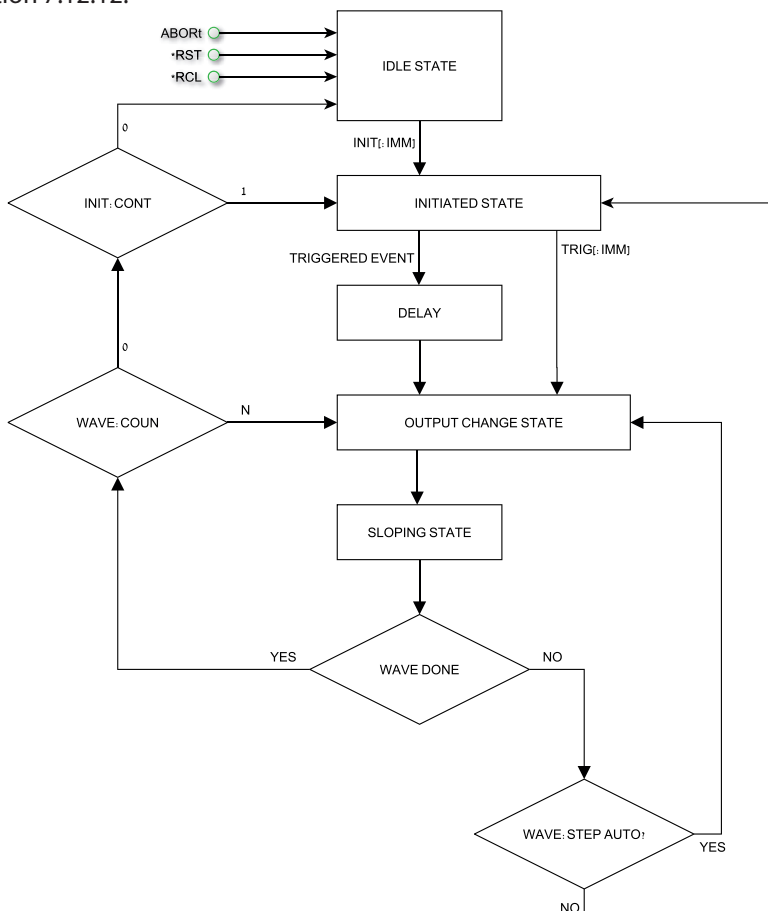

Fig.8-5: Simplified Models of Trigger in WAVE Mode

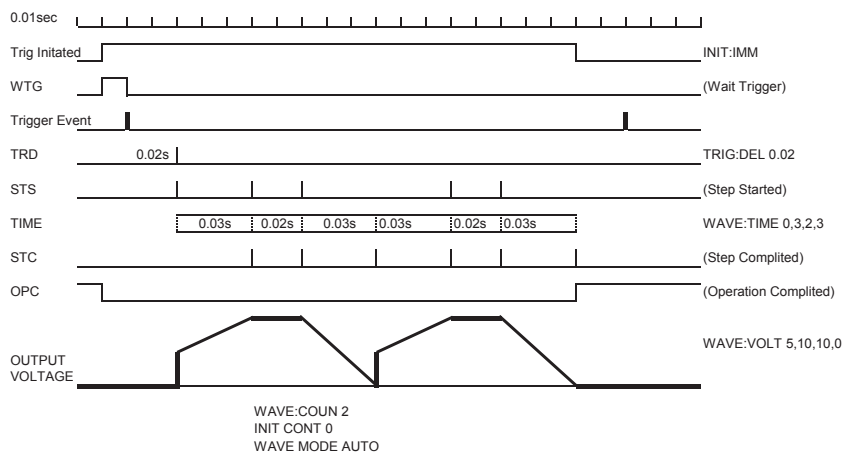

Fig.8-6: WAVE Mode Sequence example

8.5 Trigger

| Subsystem Level | Display | Function Level | Display | Parameter Level | Display | Description | |
|-----------------|---------|----------------------------|---------|--|---------|--|-------------------------------|
| Trigger Setting | TRIG | INIT | INIT | INIT | INIT | Initialization (Refer to command INIT) ready for trigger. | |
| | | | | TRIG | TRIG | | |
| | | Continue | CONT | ENA | ENA | refer to command INIT:CONT | |
| | | | | DIS | DIS | | |
| | | Trigger IN (input trigger) | TR.IN | BUS (via Software or front Panel), EXT (Analog) | BUS | BUS | refer to command TRIG:SOUR |
| | | | | | EXT | EXT | |
| | | Trigger delay | TR.DL | 0-65sec | 0.100 | refer to command TRIG:DELAY. Fine and Course modes | |
| | | Trigger OUT | TR.OUT | OFF | OFF | refer to command OUTP:TTL:MODE | |
| Trigger | TRIG | | | | | | |
| Function Strobe | F.STR | | | | | | |
| Programming | PRG | LOAD List or Wave data | LOAD | L1...L4 | L2 | Refer to commands LIST:LOAD and WAVE:LOAD | |
| | | COUNTER (set repeat time) | COUN | 1...9999 | 12 | (Refer to LIST:COUN and WAVE:COUN) allow course and fine setting | |
| | | STEP setting | STEP | ONCE | ONCE | (Refer to LIST:STEP and WAVE:STEP) | |
| | | | | AUTO | AUTO | | |
| ABORT execution | ABOR | YES | YES | (Refer to command ABORT) | | | |

Table 8-1: Trigger and Programming front panel menu

NOTE:

At AC power ON the display shows last selected program list but doesn't load it from memory.

NOTE:

If during program selection L1-L4, display shows "Err" message then program memory is empty or power supply is in initiated state. Select "ABORT" to EXIT from initiate state.

8.5.1 Input Trigger

Trigger source can be set via:

- **BUS - Command (Refer to section 7.11 *TRG, 7.12 TRIGger) or Front Panel.**
- **EXT - Rear panel connector J3-8 (Refer to section 4.3.2).**

Input Trigger source setting via Front Panel:

1. Press MENU button. MENU (green) LED illuminates. "SEL" message appears on the Voltage display.
2. Rotate Voltage encoder until "TRIG" message appears on Voltage display.
3. Press Voltage encoder. "INIT" message appears on Voltage display.
4. Rotate Voltage encoder until "TR.IN" message appears. Press Voltage encoder.
5. "TR.IN" message appears on Voltage Display and "EXT" or "BUS" messages appear on Current display. Rotate to scroll list and press Current encoder to select.

8.5.2 Output Trigger

Rear panel connector J3-3 (Refer to section 4.3.2). There are three output trigger modes: Programming Mode NONE, FIX:

- **OFF – No Trigger out.**
- **In TRIG mode, trigger is generated when output status changes.**
- **In Function Strobe mode, an output pulse is generated automatically any time an output parameter such as output, voltage or current is programmed.**

Programming modes LIST or WAVE:

- **OFF – No Trigger out.**
- **In TRIG mode, trigger is generated when LIST or WAVE is completed.**
- **In Function Strobe mode, an output pulse is generated automatically any time a step is completed.**

Output Trigger mode settings:

1. Press MENU button. MENU (green) LED illuminates. "5E1" message appears on the Voltage display.
2. Rotate Voltage encoder until "E r i" message appears.
3. Press Voltage encoder. "i n i t" message appears on Current display.
4. Rotate Voltage encoder until "E r.0 u" message appears. Press Voltage encoder.
5. "E r.0 u" message appears on Voltage Display and "OFF", "E r i", "F5E r" messages appear on Current display. Rotate to scroll list and press Current encoder to select.

8.6 Transient Waveform Example

8.6.1 Wave Programing

1. Select required transient operation mode Insert communication command (Example: VOLT:MODE WAVE).
2. Set Voltage values Insert communication command (Example: WAVE:VOLT 5,10,10,0).
3. Set Timing values Insert communication command (Example: WAVE:TIME 0,2,3,2).
4. Set Counter value for sequence execution (Example: WAVE:COUN 2).
5. Set Step parameter AUTO or ONCE (Example: WAVE:STEP AUTO).
6. In this step possible store program in memory and continue programming without PC connection Insert communication command (Example: WAVE:STORE 2).
7. Recycle AC power. Set OUT ON.

8.6.2 Wave Execution via Communication PC

1. Load stored data Insert communication command (Example: WAVE:LOAD 2)
2. Set COUNTER (How many times program will be repeated if STEP in AUTO mode). Insert communication command (Example: WAVE:COUN 2)
3. Set Trigger IN source (BUS for Command or Front Panel and EXT via Rear Panel J3-8 pin) Insert communication command (Example: TRIG:SOUR BUS)
4. Set Trigger Initialize Continue mode (If 1 then after program execution power supply will be ready for next trigger. If 0 then send INIT command to get to the next trigger. Insert communication command (Example: INIT:CONT 1)
5. Send INIT command. (Power supply ready for TRIGGER). Insert communication command (Example: INIT).
6. Send *TRG command or press Current encoder.

NOTE:

In order to be able to change the transient operation mode while the power supply is ready for trigger and not in an idle state, send ABORt and then set INIT:CONT 0.

8.6.3 Wave Execution via Front Panel

1. Load stored data MENU -> "PrOG" -> "LdAd" -> L2
2. Set Trigger IN source (BUS for Command or Front Panel and EXT via Rear Panel J3.2 pin) MENU -> "TrIG" -> "Tr.in" -> "BUS"
3. Set Trigger Initialize Continue mode (If 1 then after program execution power supply will be ready for the next trigger. If 0 then send INIT command MENU -> "TrIG" -> "Cont" -> "EnA" to get to the next trigger.
4. Set INIT command. (Power supply ready for TRIGGER) MENU -> "TrIG" -> "InIT" -> "InIT"
5. Exit from MENU and Press Current encoder to trigger.

8.7 Additional Examples

8.7.1 List Example

| | |
|---------------------------|---|
| TRIG:SOUR EXT | Select trigger source external analog signal |
| VOLT:MODE LIST | Select sequence mode "LIST" |
| LIST:VOLT 2,4,2,8,5,4 | Set voltage values "2,4,2,8,5,4"Volts |
| LIST:DWEL 0.5,0.5,1,1,1,1 | Set dwell values "0.5,0.5,1,1,1,1" seconds |
| LIST:COUN 1 | Set list execution time "1" |
| LIST:STEP AUTO | Set step execution mode "AUTO" |
| INIT:CONT OFF | Trigger subsystem enabled for a single trigger action |
| INIT | Trigger initializing |
| *TRG | Trigger command |

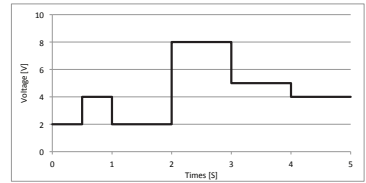

8.7.2 Waveform Example

| | |
|-------------------------------------|--|
| TRIG:SOUR BUS | Select trigger source via communication interface or front panel |
| VOLT:MODE WAVE | Select sequence mode "WAVE" |
| WAVE:VOLT 2,2,4,4,9,9,3,3 | Set voltage values "2,2,4,4,9,9,3,3"Volts |
| WAVE:TIME 0,1,0.5,0.5,0.5,0.5,1.5,1 | Set time values "0,1,0.5,0.5,0.5,0.5,1.5,1" seconds |
| WAVE:COUN 2 | Set wave execution time "2" |
| WAVE:STEP AUTO | Set step execution mode "AUTO" |
| INIT:CONT ON | Trigger system is continuously enabled |
| INIT | Trigger initializing |
| *TRG | Trigger command |

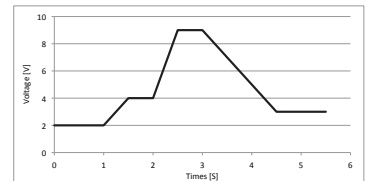

CHAPTER 9: STATUS, FAULT AND SRQ REGISTERS

9.1 General

This section describes various status errors (faults) and SRQ register structures. The registers can be read or set via the RS232/485/USB commands. Refer to Fig.9-1 for the Status and Fault Registers Diagram.

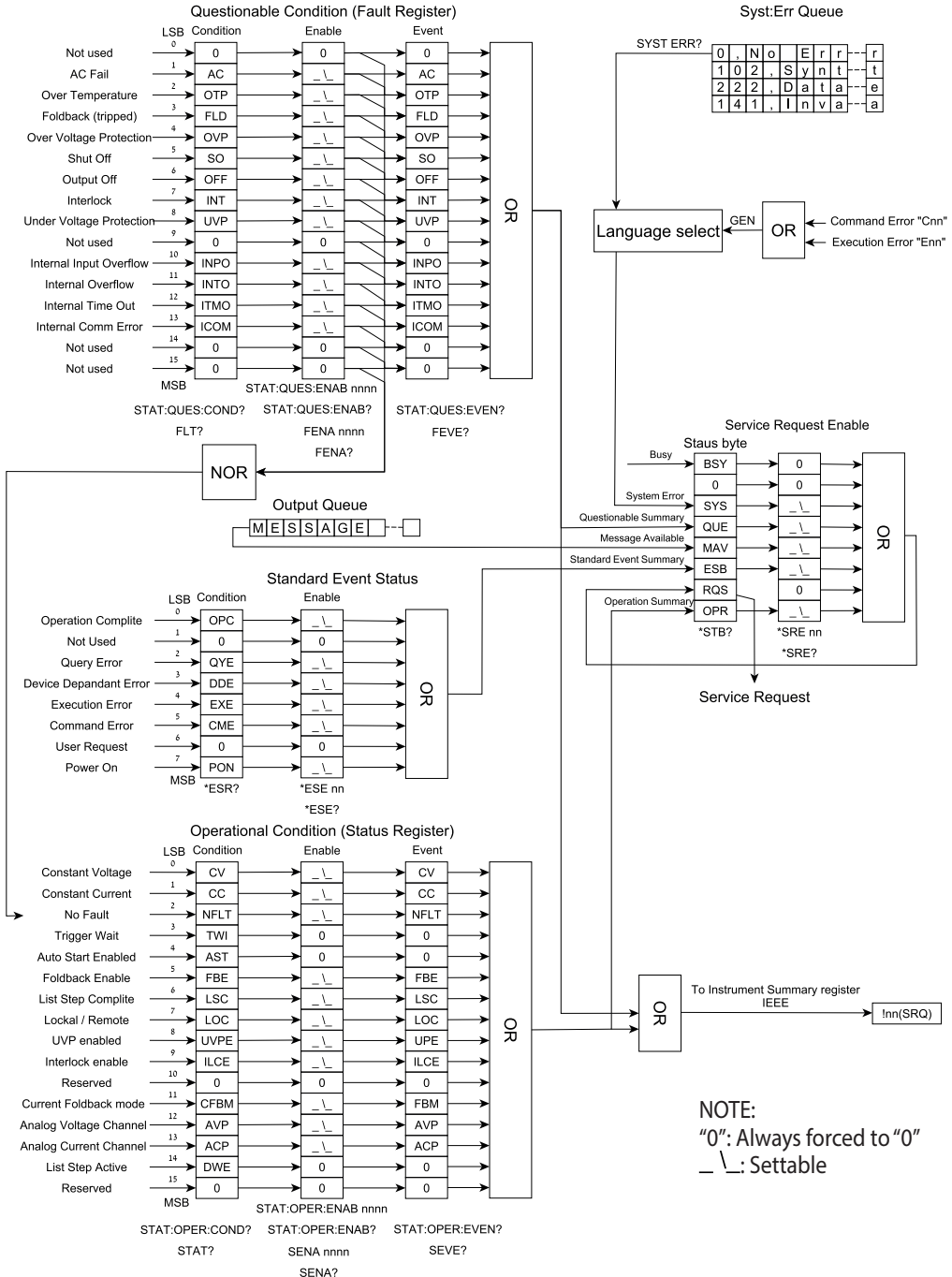

Fig.9-1: Status and Fault Registers Diagrams (SCPI)

9.2 Power Supply Status Structure

Status and Fault Register shows the status register structure of the power supply. The Standard Event, Status Byte, and Service Request Enable registers and the Output Queue perform standard functions as defined in the IEEE 488.2 Standard Digital Interface for Programmable Instrumentation. The Operation Status and Questionable Status registers implement status functions specific to the power supply.

9.3 Condition Registers

There are two registers that the user may read to see the condition of the supply. The register bits are set to show a fault or if an operating mode is active. The bits are cleared when the fault or mode is cleared. The registers are read-only.

9.3.1 Fault Register

The fault register sets a bit when a Fault occurs (Refer to table 9-1). The bit is cleared when the fault condition is removed.

| Bit Number | Decimal Value | Bit Symbol | Description |
|------------|---------------|------------|---------------------------|
| 0 | 1 | | |
| 1 | 2 | AC | AC Fail |
| 2 | 4 | OTP | Over Temperature |
| 3 | 8 | FLD | Fold Back Protection |
| 4 | 16 | OVP | Over Voltage Protection |
| 5 | 32 | SO | Shut Off |
| 6 | 64 | OFF | Output Off |
| 7 | 128 | INT | Interlock |
| 8 | 256 | UVP | Under Voltage Protection |
| 9 | 512 | 0 | Not used |
| 10 | 1024 | INPO | Internal Input Overflow * |
| 11 | 2048 | INTO | Internal Overflow * |
| 12 | 4096 | ITMO | Internal Time Out * |
| 13 | 8192 | ICOM | Internal Comm Error * |
| 14 to 15 | N/A | 0 | Not used |

Table 9-1: Bit Configuration of Questionable Registers

9.3.2 Status Register

The status register sets a bit when status changes (Refer to Table 9-2). The bit is cleared when the condition is removed.

| Bit Number | Decimal Value | Bit Symbol | Description |
|------------|---------------|------------|--|
| 0 | 1 | CV | Set high if Constant Voltage Operation |
| 1 | 2 | CC | Set high if Constant Current Operation |
| 2 | 4 | NFL | No fault |
| 3 | 8 | TW | Trigger wait |
| 4 | 16 | AST | Auto Start Enabled |
| 5 | 32 | FBE | Foldback enable |
| 6 | 64 | LSC | List step complete |
| 7 | 128 | LOC | Local / Remote |
| 8 | 256 | UVP Ena | Under voltage Protect enabled |
| 9 | 512 | ILC Ena | Interlock Enabled |
| 10 | 1024 | | |
| 11 | 2048 | FBC | Foldback CC mode enabled |
| 12 | 4096 | AVP | Remote Analog Voltage Programming mode |
| 13 | 8192 | ACP | Remote Analog Current Programming mode |
| 14 | 16384 | DWE | The list step is active (dwelling) |
| 15 | 32768 | | Reserved |

Table 9-2: Bit Configuration of Operation

9.4 Conditional, Enable and Event Registers

9.4.1 Conditional Registers.

The condition registers show a snapshot of the power supply state at the present time. Some faults or mode changes occur and clear quickly before the control computer can detect them. The change may be latched in EVENT REGISTERS so the computer can detect them even if they cleared quickly.

9.4.2 Event Registers.

Bits are sent to the Event register when a fault or mode change occurs. The bit remains set until the control computer reads the Event register or clears it. The control computer cannot tell if the fault or mode change occurred more than once since the last time the Event register was read.

9.4.3 Enable Register

The Status and Fault Enable registers are set by the user to enable SRQs in the event of changes in power supply status or fault.

9.5 Service Request

A SRQ will be sent when the contents of at least one of the event registers changes from all zeroes to any bit(s) set. When SRQ occurs, power supply sends "!\nn" message (nn-power supply address).

9.6 Standard Event Status Group

9.6.1 Register Functions

This group consists of an Event register and an Enable register that are programmed by COMMON commands. The Standard Event register latches events relating to interface communication status. It is a read-only register that is cleared when read. The Standard Event Enable register functions similarly to the Enable registers of the Operation and Questionable status groups.

9.6.2 Register Commands

The common *ESE command programs specific bits in the Standard Event Status Enable register. Because the power supply implements *PSC, the register is cleared at power on if *PSC = 1.

*ESR? reads the Standard Event Status Event register. Reading the register clears it.

| Bit | Signal | Meaning |
|-----|--------|------------------------|
| 0 | OPC | Operation complete |
| 2 | QYE | Query error |
| 3 | DDE | Device-dependent error |
| 4 | EXE | Execution |
| 6 | CME | Command error |
| 7 | PON | Power on |

Table 9-3: Standard Event Status Group

Operation Complete

Set whenever the last command is completed and the software is ready to accept another command, or when query results are available.

Query Error

Set when a query is made for which no response is available.

Device Dependent Error

Set for device specific errors. These errors are entered in the System Error Queue and have error codes greater than 0. See Table 9-6 for error descriptions.

Execution Error

Set when a parameter exceeds its allowed range.

Command Error

Set for a syntax error.

Power On

Set once at power-up. The Status Byte ESR bit is not set.

CHAPTER 10: MAINTENANCE

10.1 Introduction

This chapter provides information about maintenance, calibration and troubleshooting.

10.2 Units Under Warranty

Units requiring repair during the warranty period should be returned to a NI authorized service facility. Unauthorized repairs performed by other than the authorized service facilities may void the warranty.

10.3 Periodic Maintenance

No routine maintenance of the power supply is required except for periodic cleaning. To clean, disconnect the unit from the AC supply and allow 30sec. for discharging internal voltage. The front panel and the metal surfaces should be cleaned using a mild solution of detergent and water. The solution should be applied onto a soft cloth, and not directly to the surface of the unit. Do not use aromatic hydrocarbons or chlorinated solvents for cleaning. Use low pressure compressed air to blow dust from the unit.

10.4 Adjustments and Calibration

No internal adjustment or calibration is required. There is NO REASON to open the power supply cover.

10.5 Parts Replacement and Repairs

As repairs are made only by the manufacturer or by authorized service facilities, no parts replacement information is provided in the manual. In case of failure, unusual or erratic operation of the unit, contact the NI sales or service facility nearest you.

10.6 Troubleshooting

If the power supply appears to be operating improperly, use the troubleshooting guide to determine whether the power supply, load or external control circuits are the cause.

Configure the power supply for basic front panel operation and perform the tests listed in Section 3.8 to determine whether the problem can be found with the power supply.

Table 10-1 provides the basic checks that can be performed to diagnose problems, and references to relevant sections of this manual for further information.

| SYMPTOM | CHECK | ACTION | REF. |
|---|---|---|----------------|
| No output. All displays and indicators are blank. | Is the AC power cord defective? | Check continuity, replace if necessary. | 3.7 |
| | Is the AC input voltage within range? | Check input AC voltage. Connect to appropriate voltage source. | 3.6 3.7 |
| Output is present momentarily but shuts off quickly. The display indicates "AC". | Does the AC source voltage sag when load is applied? | Check input AC voltage. Connect to appropriate voltage source. | 3.6 |
| Output is present momentarily but shuts off quickly. the display indicates "OVP". | Is the power supply configured to Remote sense? | Check if the positive or negative load wire is loose. | 3.9.6 3.9.8 |
| Output voltage will not adjust. Front panel CC LED is on. | Is the unit in constant current mode? | Check current limit setting and load current. | 5.2.1 |
| | | | 5.2.2 |
| Output voltage will not adjust. Front panel CV LED is on. | Check if output voltage is adjusted above OVP setting or below UVL setting. | Set OVP or UVL not to limit the output. | 5.3.2 |
| | | | 5.3.3 |
| Output current will not adjust. Front panel CV LED is on. | Is the unit in constant voltage mode? | Check current limit and voltage settings. | 5.2 |
| Large ripple present in output. | Is the power supply in Remote sense? Is the voltage drop on the load wire high? | Check load and sense wire connections for noise and impedance effects. Minimize the drop on the load wires. | 3.9.4 |
| | | | 3.9.8 |
| No output. Display indicates "OVP" | Over Voltage Protection circuit is tripped. | Turn off the AC power switch. Check load connections. If analog programming is used, check if the OVP is set lower than the output. | 5.3.2 |
| No output. Front panel PROT LED is blinking. | Display indicates "Err" | Check rear panel J3 Interlock Function. | 5.7.2 |
| | Display indicates "SO" | Check rear panel J3 Output Shut Off connection. | 5.7.1 |
| | Display indicates "OEP" | Check if air intake or exhaust are blocked. Check if the unit is installed adjacent to heat generating equipment. | 5.3.6 |
| | Display indicates "FLD" | Check Foldback setting and load current. | 5.3.4 |
| Poor Load regulation Front panel CV LED is on. | Are sensing wires connected properly? | Connect the sense wires according to User's Manual instructions. | 3.9.8 |
| The front panel controls are nonfunctional. | Is the power supply in Local-Lockout mode? | Turn Off the AC power and wait until the display turns off. Turn on the AC power and press front panel REM button. | 7.2.6 |

Table 10-1: Maintenance

10.7 Fuse Rating

There are no user replaceable fuses in the power supply. Internal fuses are sized for fault protection and if a fuse was opened it will indicate that service is required. Fuse replacement should be made by qualified technical personnel. Refer to Table 10-2 for a listing of the fuses.

| | | |
|--------------------|--------------------|--------------------------|
| RMX-4101, RMX-4102 | Input AC fuse F101 | 250VAC, 10A, Fast acting |
| RMX-4104 | Input AC fuse F101 | 250VAC, 16A, Fast acting |

Table 10-2: Internal Fuse

USER MANUAL INDEX

| | | | | | |
|-----------------------|-----------------|-------------------------|--------------------|------------------|--------------------|
| A | | H | | S | |
| ac cables | 15 | humidity | 18, 22, 26, 30 | safe start | 59, 62, 71, 88, 99 |
| ac fail | 62 | hyper terminal | 88 | safety | 9 |
| accessories | 15 | | | SCPI | 80, 81, 92 |
| acknowledge | 85 | I | | series operation | 62 |
| address | 80, 85, 87, 102 | Identification Commands | 86, 95 | shield | 15, 41, 42, 43 |
| auto restart | 59, 88, 99 | initialization | 87, 96, 122 | shut off | 53, 69, 70 |
| | | installation | 35 | specifications | 16, 132 |
| B | | interlock | 60, 69, 70, 91 | srq | 81, 125 |
| backspace | 85 | isolated | 50, 132 | status command | 91, 94 |
| baud rate | 81 | | | subsystem | 65, 69, 73, 99 |
| | | L | | T | |
| C | | last setting memory | 73 | TXD | 82, 85 |
| calibration | 135 | linking cable | 14, 15, 84 | TX (RS232) | 82 |
| configuration | 80 | line feed | 85, 92 | trigger | 53, 98, 112, 122 |
| checksum | 85, 86, 93, 131 | list mode | 107, 120 | U | |
| communication | 14, 15, 56, 80 | local operation | 58 | UVL | 38, 61, 88, 90 |
| constant current | 38, 52, 58, 72 | local sensing | 37, 41, 43, 45 | UVP | 61, 62, 88, 90 |
| constant voltage | 38, 52, 58, 72 | M | | USB | 50, 80, 84 |
| cooling | 14, 36 | maintenance | 135, 136 | | |
| | | Master/Slave | 65, 88 | W | |
| D | | | | warranty | 8, 135 |
| daisy-chain | 69, 84 | O | | wave mode | 113, 121 |
| display | 48, 54, 106 | otp | 62 | wire size | 40 |
| | | outline | 32, 33, 34 | | |
| E | | over voltage | 38, 60 | | |
| enable/disable | 53, 59, 70 | P | | | |
| error message | 85, 111, 130 | parallel operation | 52, 65 | | |
| external resistor | 78 | parity | 85, 92 | | |
| external voltage | 77 | PS_OK | 53, 64, 69, 70, 72 | | |
| | | preview | 49, 87 | | |
| F | | R | | | |
| fine | 49, 58 | rackmount | 35 | | |
| fix mode | 119 | rear panel | 48 | | |
| foldback | 39, 61, 66, 88 | remote sensing | 43, 45, 50 | | |
| fuse | 9, 136 | registers structure | 125 | | |
| front panel control | 48 | RS232 | 50, 80, 82 | | |
| front panel lock | 49 | RS485 | 50, 80, 82 | | |
| | | | | | |
| G | | | | | |
| GEN protocol | 85 | | | | |
| grounding | 10, 45 | | | | |
| global output command | 89 | | | | |

