

Document prepared and responsible for					
M. Obritzhauser		Standard Programme			
Responsible for technical data		Day	Month	Year	Revision
M. Obritzhauser		11	11	05	D

# EGSTON

## Switch Mode Power Supply

**Product Name: P2xFSW3 24W**

**Standard Programme**

**Input: 90 - 264 V AC**

**Output : 5V – 24V  
max. 24W  
max. 2,5A**

**Type: P2xFSW3 24W**

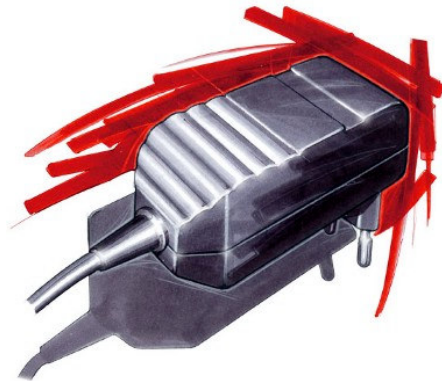

### CONFIDENTIAL

This document contains proprietary information originated and/or owned by EGSTON GmbH. This information shall not be duplicated, used or disclosed in whole, or in part, to any other party or used for any other purpose without the prior consent of EGSTON GmbH.

Copyright © 2004 EGSTON GmbH.  
A-3730 Eggenburg, Grafenberger Strasse 37  
All Rights Reserved.

Document prepared and responsible for					
M. Obritzhauser		Standard Programme			
Responsible for technical data		Day	Month	Year	Revision
M. Obritzhauser		11	11	05	D

1.1	Evolution .....	3
2	Scope .....	3
3	Technical Specification Sheet .....	4
3.1	Input Specification .....	4
3.2	Safety and Environmental Conditions .....	4
3.3	Output Specification .....	5
3.3.1	Output template .....	6
3.3.2	Output Ripple Voltage .....	7
3.4	Mechanical Parameters .....	9
3.5	Housing dimension .....	9
3.5.1	Euro housing .....	9
3.5.2	US Housing .....	10
3.5.3	UK Housing .....	10
3.5.4	Desk Top Housing .....	11
3.5.5	Australia Housing .....	12
3.5.6	Housing Material .....	12
3.6	Cable And Connector .....	12
4	Marking on the housing .....	13
4.1	Plug In Devices .....	13
4.1.1	EU/UK devices .....	13
4.1.2	US devices .....	14
4.1.3	Australia Housing .....	14
4.2	Desktop Devices .....	15
5	EMC .....	16
5.1	Emission with representative 15V device: .....	16
5.2	Immunity To Flicker .....	18
5.3	Immunity to Fast Transients (Burst) .....	18
5.4	Immunity to Radiated Electromagnetic Field .....	18
5.5	Immunity to Electrostatic Discharge .....	18
5.6	Surge Capability .....	18
5.7	Immunity to conducted disturbances .....	18
5.8	Immunity to voltage dips, short interruptions and voltage variations .....	18
6	Reliability .....	19
6.1	MTBF .....	19
6.2	Maintainability .....	19
7	Safety .....	20
7.1	Dielectric Strength .....	20
7.2	Over-current Protection .....	20
7.3	Single Component Failure .....	20
7.4	Short Circuit .....	20
8	Approvals and test standards .....	21
8.1	Test Standards .....	21
8.2	Approvals .....	21
8.2.1	EU/UK devices .....	21
8.2.2	US devices .....	22
8.2.3	Desktop Devices .....	22
8.2.4	Australia Devices .....	22
9	Ordering Information .....	23
10	Packaging and weight .....	24
11	Specials Features: .....	25
11.1	Output voltage tolerance 1% .....	25
11.2	Visual operation Display (green LED) .....	25
11.3	Current regulation .....	25
11.4	Cable Compensation with 4 wire system .....	25
11.5	Pluggable secondary cable .....	25
11.6	Customer specific secondary Plug .....	25
11.7	Print module .....	25

	<b>PRODUCT SPECIFICATION P2xFSW3 24W</b>			Page 3/25
	Document prepared and responsible for			
	M. Obritzhauser		Standard Programme	
	Responsible for technical data	Day	Month	Year
M. Obritzhauser	11	11	05	D

## 1.1 Evolution

<b>Edition</b>	<b>Date</b>	<b>Responsible</b>	<b>Reason of change</b>
A	28.05.2003	Obritzhauser	First edition
B	29.07.2003	Obritzhauser	EMC Standards Revised
C	04.02.2004	Obritzhauser	Voltage Range Extended
D	11.11.2005	Obritzhauser	Australia Version implemented

## 2 SCOPE

This document describes a switch mode power supply unit (AC/DC converter) with fixed output voltage.

The unit is designed as a Wall Plug In power supply or a Desk Top Module.

	<b>PRODUCT SPECIFICATION P2xFSW3 24W</b>			Page 4/25			
	Document prepared and responsible for						
	M. Obritzhauser			Standard Programme			
	Responsible for technical data			Day	Month	Year	Revision
	M. Obritzhauser			11	11	05	D

### 3 TECHNICAL SPECIFICATION SHEET

#### 3.1 Input Specification

Parameter	Key	Min	Typ.	Max	Unit	Test Cond.
Input Voltage	$U_{IN}$	90		264	V	AC
Input Current	$I_{IN}$	9	550	620	mA	
Input Frequency	$f_{IN}$	47		63	Hz	
Efficiency	$\eta$	75		85	%	At full load
Switching Frequency	$f_{sw}$		40		kHz	
Stand-by power	$P_{stb}$		650		mW	Without load

#### Input Voltage

If the input voltage is out of operating range, the power supply does not meet the full specification. Above the specified upper limit of the input voltage the unit can get damaged. Below the specified lower limit of the input voltage the unit does not meet the specification.

#### Efficiency Under Load

The efficiency is defined as the ratio between the output power and input power.

#### 3.2 Safety and Environmental Conditions

Parameter	Key	Min	Typ.	Max	Unit	Test Cond.
Dielectric Strength		4,24			KV <sub>DC</sub>	
Operating Temperature		-5		40	°C	
		23		104	°F	
Storage Temperature		-30	25	80	°C	
		-22	77	176	°F	
Humidity				95	%	

	<b>PRODUCT SPECIFICATION P2xFSW3 24W</b>			Page 5/25		
	Document prepared and responsible for					
	M. Obritzhauser		Standard Programme			
	Responsible for technical data		Day	Month	Year	Revision
	M. Obritzhauser		11	11	05	D

### 3.3 Output Specification

Parameter	Key	Min	Typ.	Max	Unit	Test Cond.	Available on request
Output Voltage	$U_2$	5		24	V	0 – 2,5 A	
Output voltage tolerance	$T_{U2}$			3	%	at PCB	1% Cable compensation
Output Current	$I_{2 \text{ Nominal}}$	2,5			A		Current regulation, 3A
Max. Overload current	$I_{2 \text{ Overload}}$		180 160		% of $I_{2 \text{ Nominal}}$	$U_{IN} = 264V$ $U_{IN} = 90V$	
Output Power	$P_2$		24		W		
Ripple Voltage	$U_{2,rms}$			50 50	$mV_{rms}$	$U_{IN} = 264V$ $U_{IN} = 90V$	

The unit is not long time overload proof. If the unit is powered longer than 1 min in overload conditions (current range between  $I_{2 \text{ Nominal}}$  and  $I_{2 \text{ Overload}}$ ), the device can be damaged.

	<b>PRODUCT SPECIFICATION P2xFSW3 24W</b>			Page 6/25		
	Document prepared and responsible for					
	M. Obritzhauser		Standard Programme			
	Responsible for technical data		Day	Month	Year	Revision
	M. Obritzhauser		11	11	05	D

### 3.3.1 Output template

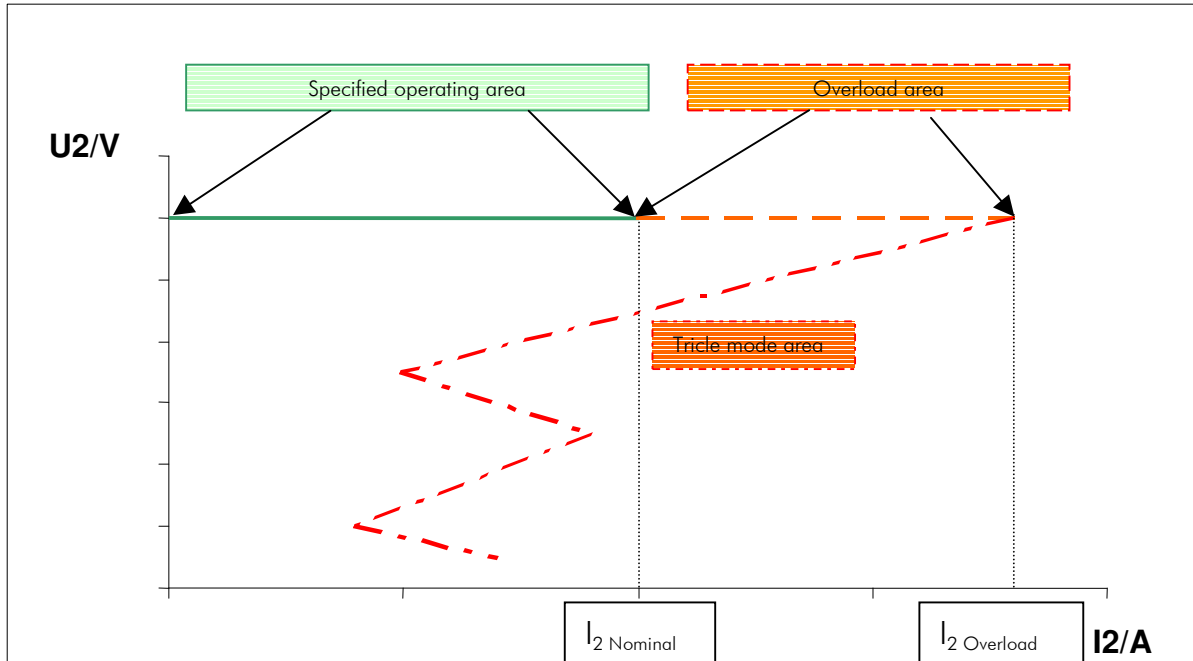

#### Specified operating area:

At an output current from 0A to  $I_{2\text{ Nominal}}$  the unit fulfills all specified data.

#### Overload area:

At an output current from  $I_{2\text{ Nominal}}$  to  $I_{2\text{ Overload}}$  the power supply delivers the specified output voltage  $U_2$ .

The unit is not long time overload proof. If the unit is powered longer than 1 min in overload conditions, the device can be damaged.

#### Trickle mode area:

If the power demand would be greater than  $I_{2\text{ Overload}}$  or the power supply works in short circuit the output voltage and current can not be defined (this parameters are not stable). The wattage of the SMPS is de-rated. In this mode the unit can not be damaged. After removing this conditions the unit fulfills the specification.

	<b>PRODUCT SPECIFICATION P2xFSW3 24W</b>			Page 7/25	
	Document prepared and responsible for				
	M. Obritzhauser		Standard Programme		
	Responsible for technical data		Day	Month	Year
M. Obritzhauser		11	11	05	D

### 3.3.2 Output Ripple Voltage

The output ripple voltage is measured with an oszilloscope 20Mhz band limited at a representative 15V sample.

#### 3.3.2.1 Measurement at 230V input voltage and 1,6A load

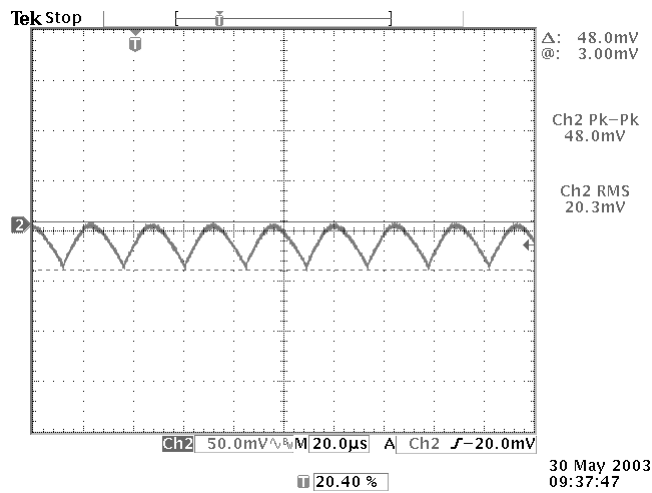

Ripple Voltage at switching frequency measured at a temperature of +25°C

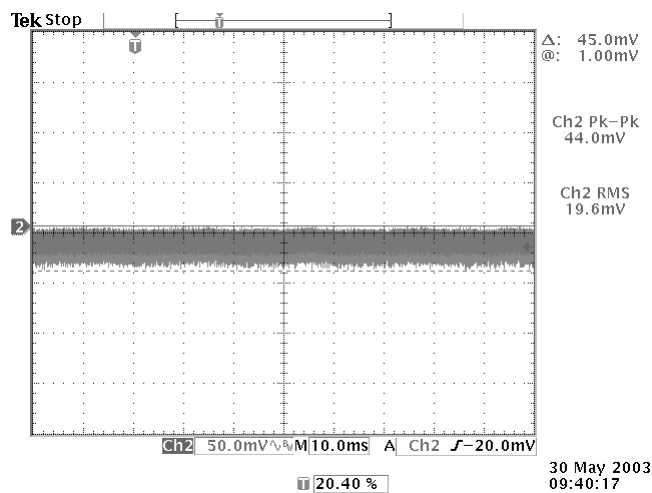

Ripple Voltage at mains frequency measured at a temperature of +25°C

Document prepared and responsible for					
M. Obritzhauser		Standard Programme			
Responsible for technical data		Day	Month	Year	Revision
M. Obritzhauser		11	11	05	D

### 3.3.2.2 Measurement at 120V input voltage and 1,6A load

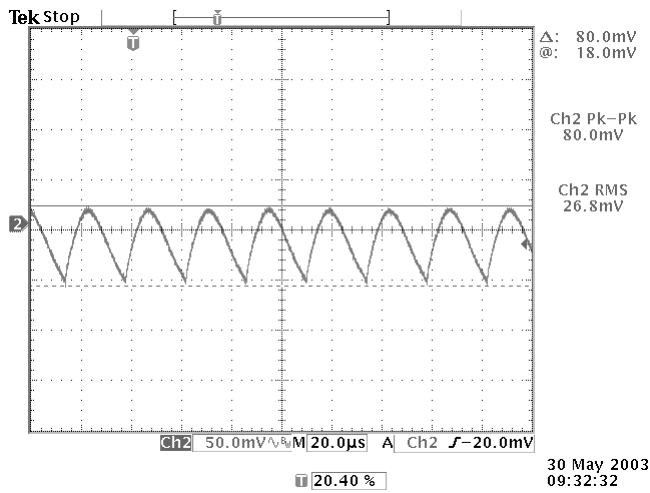

Ripple Voltage at switching frequency measured at a temperature of +25°C

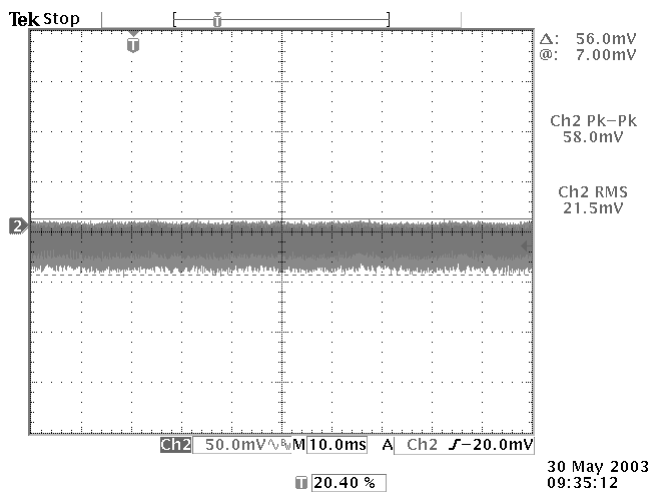

Ripple Voltage at mains frequency measured at a temperature of +25°C



### 3.4 Mechanical Parameters

### 3.5 Housing dimension

#### 3.5.1 Euro housing

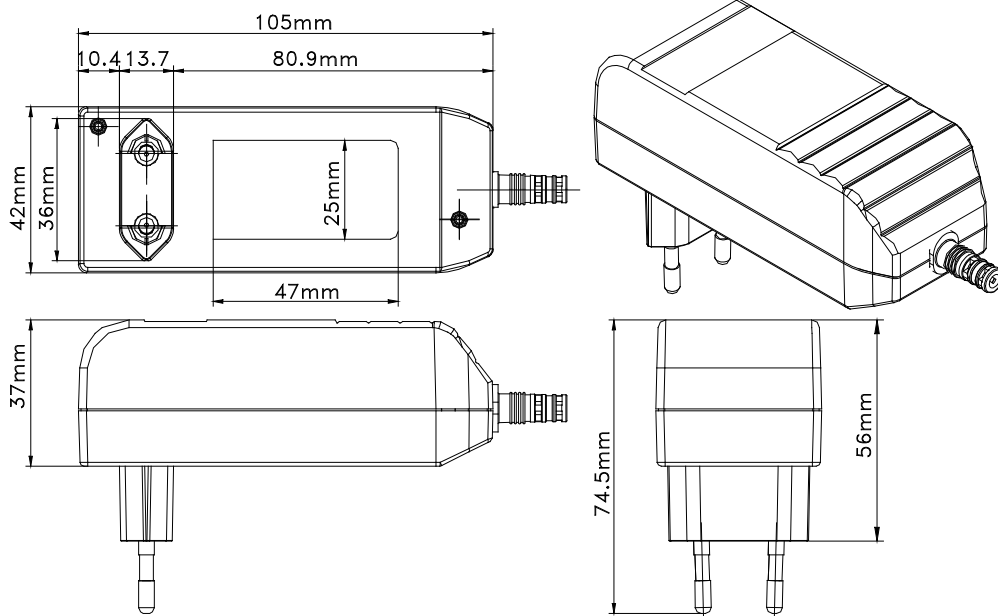

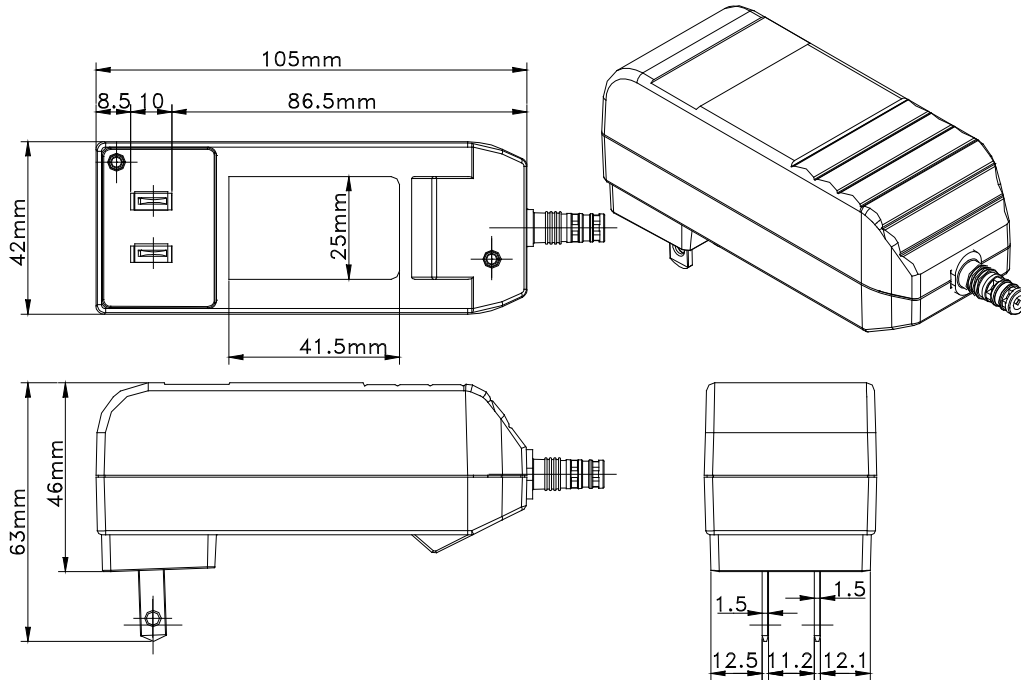

Document prepared and responsible for			
M. Obritzhauser		Standard Programme	
Responsible for technical data		Day	Month
M. Obritzhauser		11	11
		Year	Revision
		05	D

### 3.5.2 US Housing

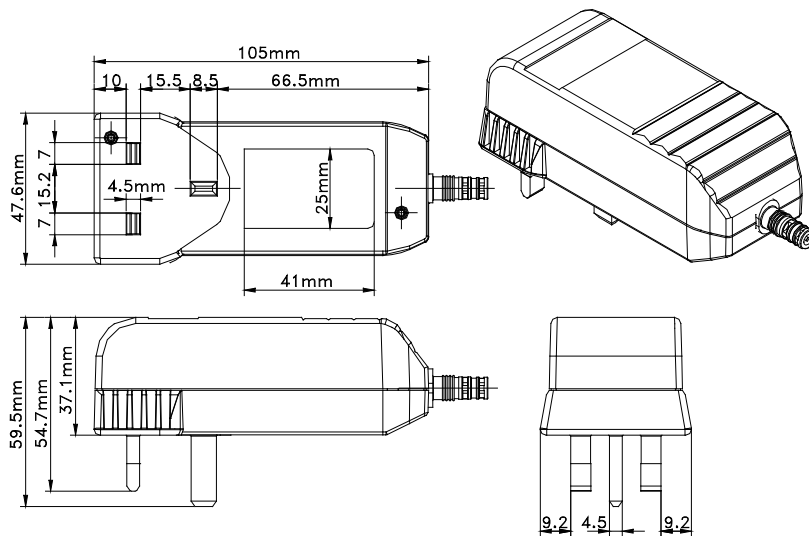

### 3.5.3 UK Housing



	<b>PRODUCT SPECIFICATION P2xFSW3 24W</b>			Page 11/25	
	Document prepared and responsible for M. Obritzhauser		Standard Programme		
	Responsible for technical data M. Obritzhauser		Day 11	Month 11	Year 05
			Revision D		

### 3.5.4 Desk Top Housing

With IEC 320 C14 Primary Plug

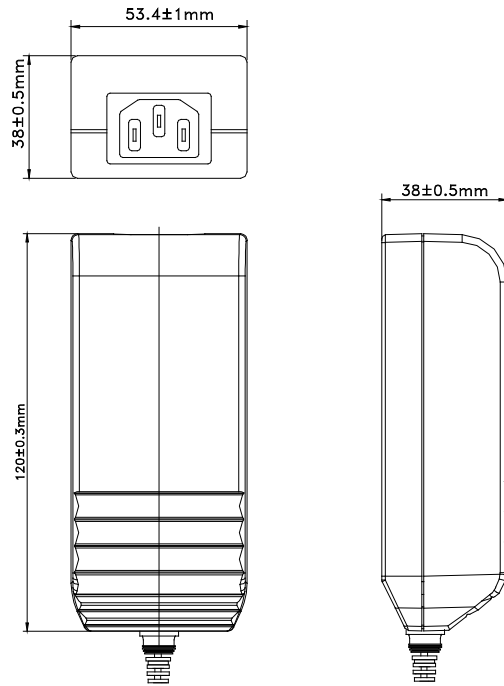

With IEC 320 C8 primary Plug

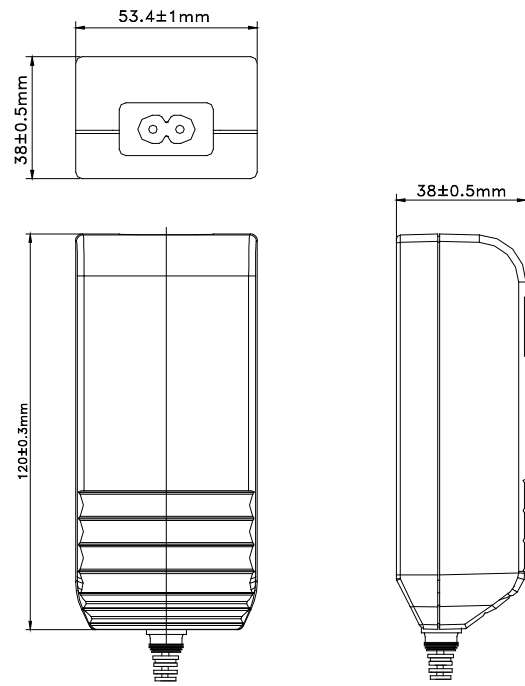

	<b>PRODUCT SPECIFICATION P2xFSW3 24W</b>			Page 12/25	
	Document prepared and responsible for		Standard Programme		
	M. Obritzhauser		Standard Programme		
	Responsible for technical data		Day	Month	Year
M. Obritzhauser		11	11	05	D

### 3.5.5 Australia Housing

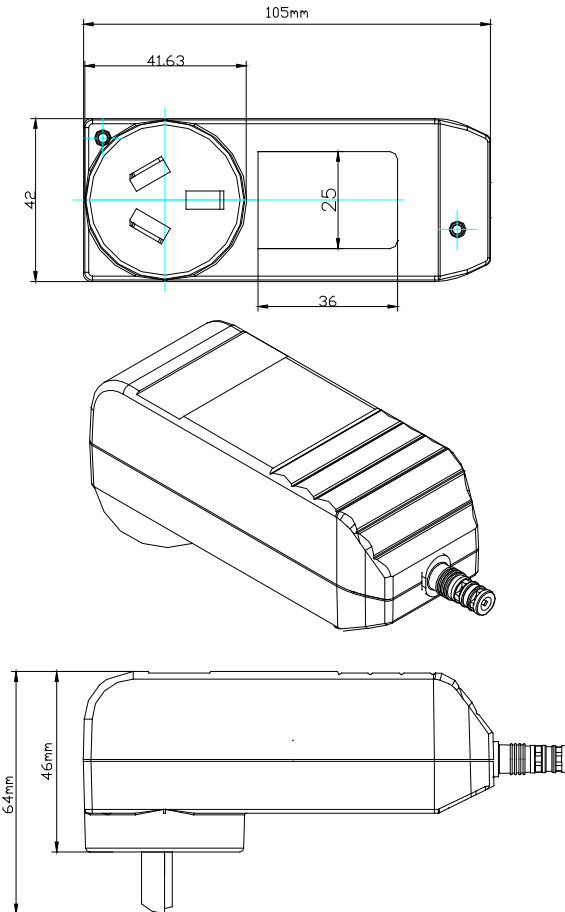

### 3.5.6 Housing Material

	24W UK,EURO,US, AUS	DESKTOP
Material	PA6	PA6,
Flammability rate	V0	V0

### 3.6 Cable And Connector

According to customer's requirements.

	<b>PRODUCT SPECIFICATION P2xFSW3 24W</b>			Page 13/25		
	Document prepared and responsible for					
	M. Obritzhauser		Standard Programme			
	Responsible for technical data		Day	Month	Year	Revision
	M. Obritzhauser		11	11	05	D

## 4 MARKING ON THE HOUSING

### 4.1 Plug In Devices

#### 4.1.1 EU/UK devices

Laser marking  
 Product name  
 Input parameters  
 Output parameters  
 Product code  
 Safety Instructions

 Conformity Mark with the EU low voltage directive and EMC directive



ENEC Mark



GS Mark

	<b>PRODUCT SPECIFICATION P2xFSW3 24W</b>			Page 14/25	
	Document prepared and responsible for				
	M. Obritzhauser		Standard Programme		
	Responsible for technical data	Day	Month	Year	Revision
M. Obritzhauser		11	11	05	D

#### 4.1.2 US devices

Laser marking  
 Product name  
 Input parameters  
 Output parameters  
 Product code  
 Safety Instructions



Conformity Mark with the EU low voltage directive and EMC directive



GS Mark



UL Mark for Canada and the United States

#### 4.1.3 Australia Housing

Laser marking  
 Product name  
 Input parameters  
 Output parameters  
 Product code  
 Safety Instructions  
 Australia Approval Mark

	<b>PRODUCT SPECIFICATION P2xFSW3 24W</b>			Page 15/25	
	Document prepared and responsible for				
	M. Obritzhauser		Standard Programme		
	Responsible for technical data	Day	Month	Year	Revision
M. Obritzhauser		11	11	05	D

## 4.2 Desktop Devices

Laser marking  
 Product name  
 Input parameters  
 Output parameters  
 Product code  
 Safety Instructions



Conformity Mark with the EU low voltage directive and EMC directive



ENEC Mark



GS Mark



UL Mark for Canada and the United States

Document prepared and responsible for			
M. Obritzhauser		Standard Programme	
Responsible for technical data		Day	Month
M. Obritzhauser		11	11
		Year	Revision
		05	D

## 5 EMC

The units meet the following EMC requirements:

### 5.1 Emission with representative 15V device:

Test passed according to EN55022 Class B.

Primary: 230V AC, Secondary: 15V / 1600mA , Temperature: 25°C, Load connected to ground, Peak and Average Measurement.

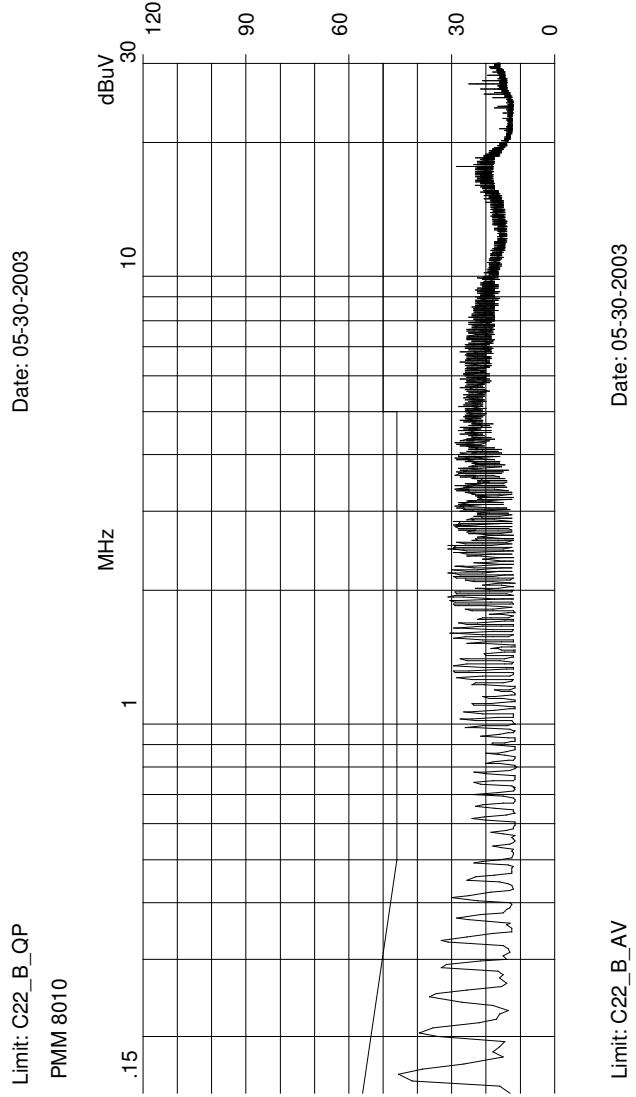
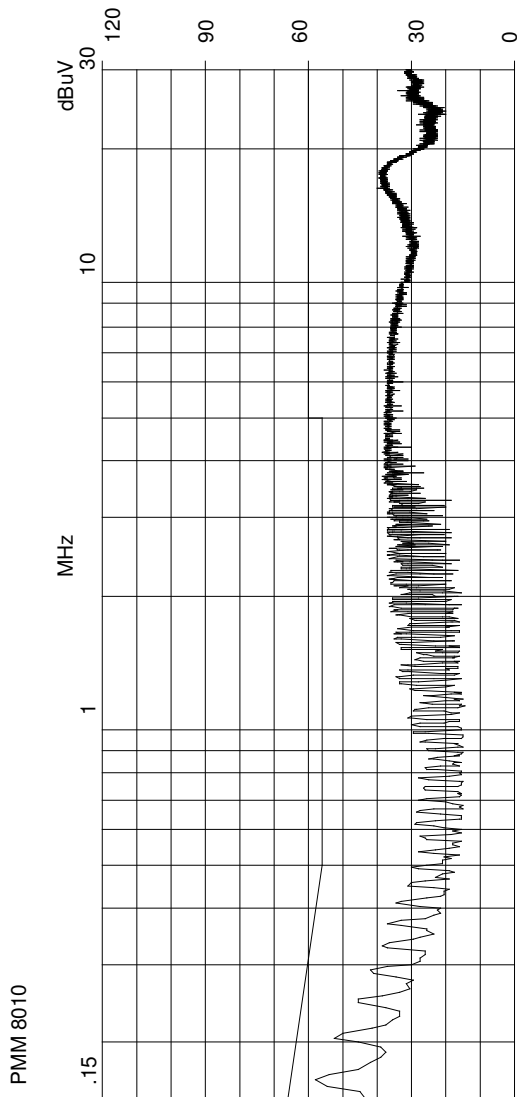



	<b>PRODUCT SPECIFICATION P2xFSW3 24W</b>			Page 17/25	
	Document prepared and responsible for M. Obritzhauser		Standard Programme		
	Responsible for technical data M. Obritzhauser		Day 11	Month 11	Year 05
			Revision D		

Test passed according to FCC15 Class B.

Primary: 120V AC, Secondary: 15V / 1600mA , Temperature: 25°C, Load connected to ground, Peak Measurement

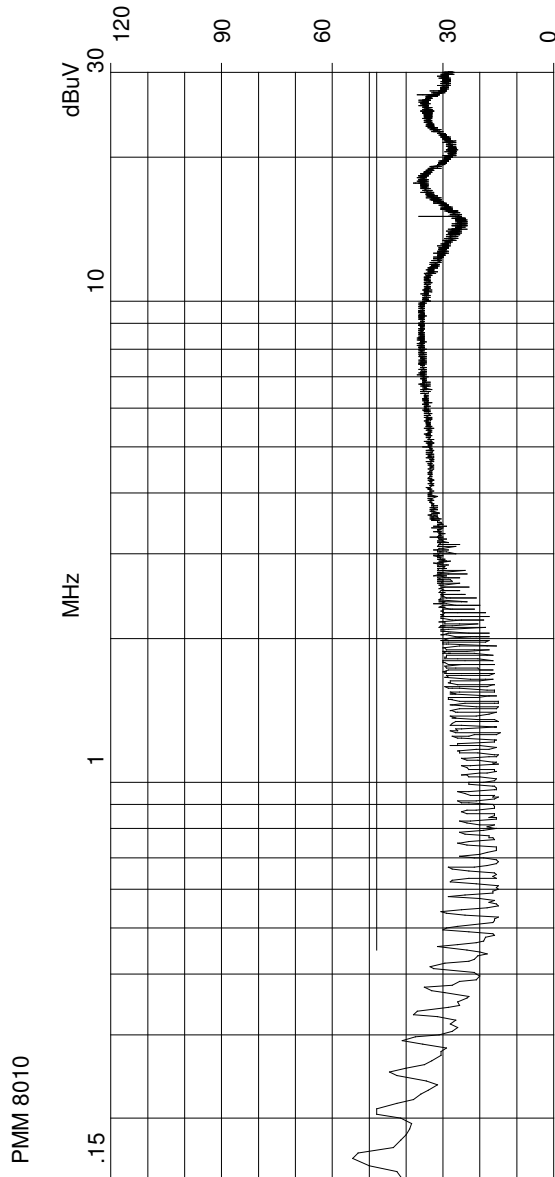

Date: 05-30-2003

Limit: FCC\_15\_B

	<b>PRODUCT SPECIFICATION P2xFSW3 24W</b>			Page 18/25	
	Document prepared and responsible for				
	M. Obritzhauser		Standard Programme		
	Responsible for technical data	Day	Month	Year	Revision
M. Obritzhauser		11	11	05	D

## 5.2 Immunity To Flicker

Test according to EN 61000-3-2

## 5.3 Immunity to Fast Transients (Burst)

Test according to EN61000-4-4

Input Line: 2.0kV – 5/50 ns – 5.0 kHz

Output Line: 2.0kV – 5/50 ns – 5.0 kHz

## 5.4 Immunity to Radiated Electromagnetic Field

Test according to EN 61000-4-3

Test characteristic: 80 – 1000 MHz; 80% AM (1kHz), 3V/m

## 5.5 Immunity to Electrostatic Discharge

Test according to EN 61000-4-2

Test characteristic: Contact discharge 6kV

Air discharge 8kV

## 5.6 Surge Capability

Test according to EN61000-4-5

Test characteristic: line to line: 1kV Surge

line to earth: 2kV Surge

## 5.7 Immunity to conducted disturbances

Test according to EN 61000-4-6

Test characteristic: 150kHz – 80 MHz; 80% AM (1kHz), 3V

## 5.8 Immunity to voltage dips, short interruptions and voltage variations

Test according to EN 61000-4-11

Test criterion C

	<b>PRODUCT SPECIFICATION P2xFSW3 24W</b>			Page 19/25
	Document prepared and responsible for			
	M. Obritzhauser		Standard Programme	
	Responsible for technical data	Day	Month	Year
M. Obritzhauser	11	11	05	D

## 6 RELIABILITY

### 6.1 MTBF

at 240V input voltage  $\geq 1.400.000$  hours

at 100V input voltage  $\geq 1.600.000$  hours

MTBF calculation according SN 29500 at 40°C ambient temperature

### 6.2 Maintainability

The power supply is not to be repaired.

	<b>PRODUCT SPECIFICATION P2xFSW3 24W</b>			Page 20/25
	Document prepared and responsible for			
	M. Obritzhauser		Standard Programme	
	Responsible for technical data	Day	Month	Year
M. Obritzhauser	11	11	05	D

## 7 SAFETY

The units pass the following tests:

### 7.1 Dielectric Strength

The input isolation test voltage is 3kV 50/60 Hz, sinusoidal waveform. Test duration is 2 seconds for 100% test, 1 minute 4,24KV DC or lot-test.

### 7.2 Over-current Protection

The unit is not long time over-current proof. If the unit is powered longer than 1 min in overload conditions, the device can be damaged.

### 7.3 Single Component Failure

A single component failure does not cause any damage to persons or ambient (fire, explosions, etc).

### 7.4 Short Circuit

The power supply is designed with a short circuit protection. A shortened output does not cause any damage to persons or ambient (fire, explosions, etc.) After removing this conditions the unit fulfills the specification.

	<b>PRODUCT SPECIFICATION P2xFSW3 24W</b>			Page 21/25	
	Document prepared and responsible for				
	M. Obritzhauser		Standard Programme		
	Responsible for technical data	Day	Month	Year	Revision
M. Obritzhauser		11	11	05	D

## 8 APPROVALS AND TEST STANDARDS

### 8.1 Test Standards

EN/IEC 60 950 -1  
 UL 1310  
 EN 61000-6-1  
 EN 55022  
 EN 55011  
 EN 55014-1  
 EN 61204-3

### 8.2 Approvals

#### 8.2.1 EU/UK devices

 Conformity with the EU low voltage directive and EMC directive



	<b>PRODUCT SPECIFICATION P2xFSW3 24W</b>			Page 22/25
	Document prepared and responsible for			
	M. Obritzhauser		Standard Programme	
	Responsible for technical data	Day	Month	Year
M. Obritzhauser	11	11	05	D

### 8.2.2 US devices

 Conformity with the EU low voltage directive and EMC directive



GS



UL for Canada and the United States

### 8.2.3 Desktop Devices

 Conformity with the EU low voltage directive and EMC directive



ENEC



GS



UL for Canada and the United States

### 8.2.4 Australia Devices

Queensland Government – Department of Industrial Relations  
Egston approval number: Q050400

	<b>PRODUCT SPECIFICATION P2xFSW3 24W</b>			Page 23/25		
	Document prepared and responsible for					
	M. Obritzhauser		Standard Programme			
	Responsible for technical data		Day	Month	Year	Revision
	M. Obritzhauser		11	11	05	D

## 9 ORDERING INFORMATION

	<b>POWER CLASS</b>	<b>24 Watt</b>
<b>P</b>	<b>SUPPLY TYPE</b>	<b>P = New Generation Power Supply</b>
<b>2</b>	<b>OPERATION TEMP. RANGE</b>	<b>2 = -5°C to +40°C</b>
<b>E</b>	<b>PRIMARY CONNECTOR</b>	<b>E = Euro plug</b> <b>U = US/Japan/Canada Plug</b> <b>G = United Kingdom Plug</b> <b>D = Desktop Module</b> <b>A = Australia Module</b>
<b>F</b>	<b>CABLE CONNECTION</b>	<b>F = Fixed</b>
<b>S</b>	<b>APPLICATION</b>	<b>S = Standard</b> <b>M = Medical</b> <b>H = Household</b>
<b>W</b>	<b>WIDE INPUT RANGE</b>	<b>W = 90V-264V</b>
<b>3</b>	<b>OUTPUT STABILITY</b>	<b>3 = 3%</b>
<b>24W</b>	<b>HOUSING DIMENSION</b>	<b>24W</b>
<b>12V</b>	<b>OUTPUT VOLTAGE</b>	<b>5V-24V</b>
<b>2A</b>	<b>OUTPUT CURRENT</b>	<b>2500mA max.</b>

	<b>PRODUCT SPECIFICATION P2xFSW3 24W</b>			Page 24/25		
	Document prepared and responsible for					
	M. Obritzhauser			Standard Programme		
	Responsible for technical data			Day	Month	Year
M. Obritzhauser			11	11	05	D

## 10 PACKAGING AND WEIGHT

Cable with connector 5.5/2.1	38 g
Instruction Manual	3.6 g
Euro pallet empty (wooden):	21 kg

SINGLE PACKAGING													
			PS 1.5m cable+ connector 5.5/2.1	Single carton empty	Single carton full	Packing case empty	Packing unit	Packing case full	Cartons per pallet	Euro pallet full	Single carton	Packing case	Euro pallet
P2	EU	24W	168	15	187	180	50	9.6	18	211	136x76x43.5	388x280x226	1200x800x
P2	US	24W	168	15	187	180	50	9.6	18	194	136x76x43.5	388x280x226	1200x800x
P2	Uk	24W	168	16	188	180	50	9.6	18	194	136x76x50.5	388x280x260.5	1200x800x
Unit			g	g	g	g	Pcs.	kg	Pcs.	kg	mm	mm	mm



	<b>PRODUCT SPECIFICATION P2xFSW3 24W</b>			Page 25/25
	Document prepared and responsible for			
	M. Obritzhauser		Standard Programme	
	Responsible for technical data	Day	Month	Year
M. Obritzhauser	11	11	05	D

## 11 SPECIALS FEATURES:

Following Specials can be offered on request

### 11.1 Output voltage tolerance 1%

The output voltage can be adjusted with a tolerance of  $\pm 1\%$ .

### 11.2 Visual operation Display (green LED)

When the green LED is shining the output voltage is delivered.

### 11.3 Current regulation

The secondary voltage will be reduced when the selected output current is reached.

The max. Current which can be selected is 80% of  $I_{2\text{Nominal}}$ .

The current regulation can be delivered at the secondary voltage range from 5 to 24V.

### 11.4 Cable Compensation with 4 wire system

The voltage drop of the secondary cable will be compensated.

The maximum output wattage is defined at the PCB.

### 11.5 Pluggable secondary cable

Only available at Egston Standard Wall Plug In Powersupplies.

### 11.6 Customer specific secondary Plug

### 11.7 Print module

The power supply is built in a housing which can be soldered on to a PCB.