

For mating dimensions see MIL-DTL-38999 Series III

Reference MIL-STD-1560 for insert arrangement details. For non-MS arrangements consult Amphenol.

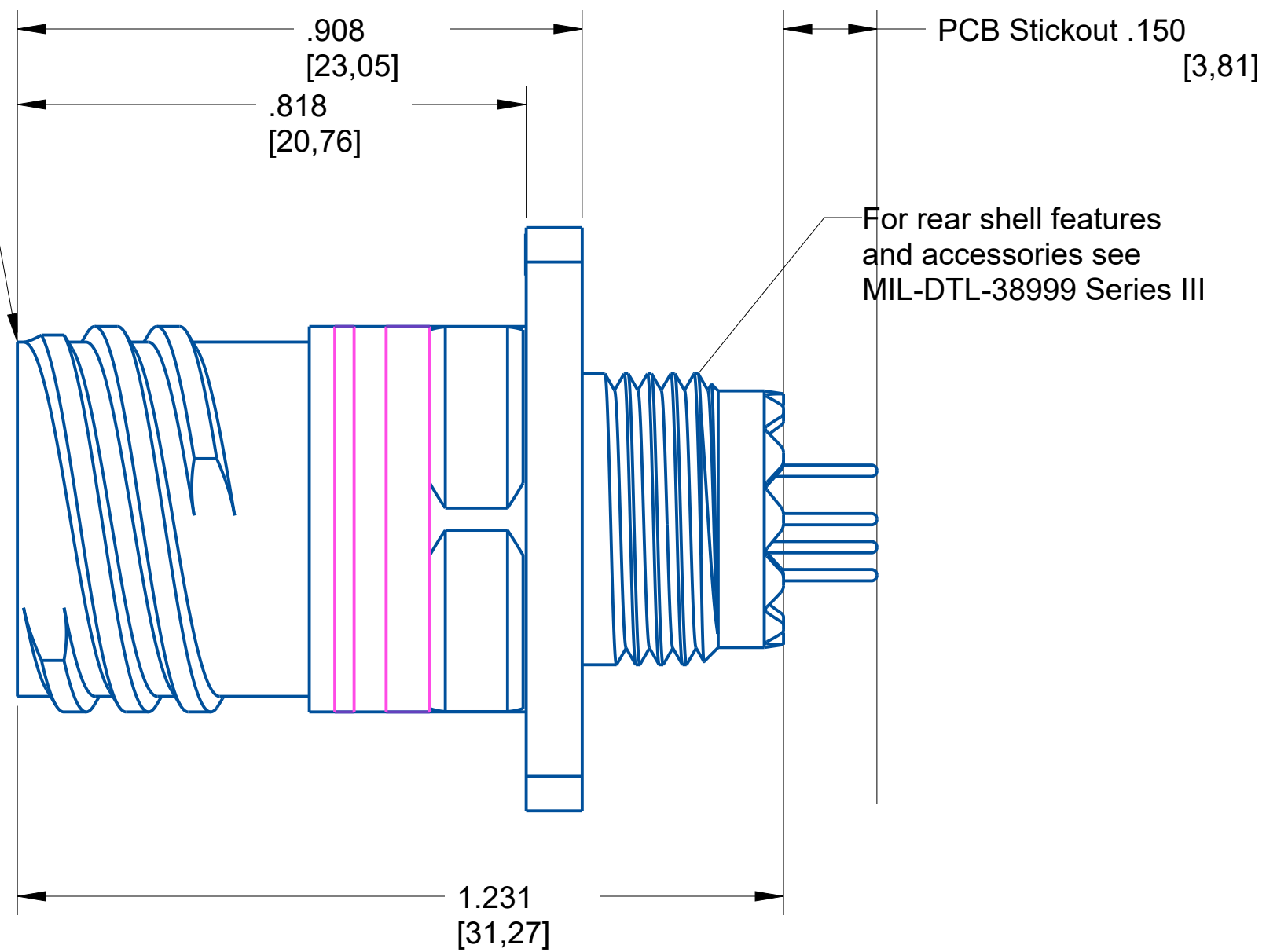

For rear shell features and accessories see MIL-DTL-38999 Series III

**NOTE:**  
 -DRAWING NOT TO SCALE  
 -DIMENSIONS SUBJECT TO CHANGE  
 -DIMENSIONS ARE IN INCHES [MM]

PROPERTY OF AMPHENOL AEROSPACE. ALL RIGHTS RESERVED.

Meets applicable requirements of MIL-DTL-38999  
 Base Material: Aluminum  
 Plating: AP-93

<b>AMPHENOL CORPORATION</b> <small>40-60 DELAWARE AVENUE SIDNEY, N.Y. 13838</small>			
RECEPTACLE Electrical Connector TVPS00			U
SIZE <b>C</b>	CAGE CODE <b>77820</b>	CODED NUMBER <b>TVPS00DS-9-35P(P15)</b>	REV <b>X1</b>
SHEET 1 OF 1			

# Insert Arrangement

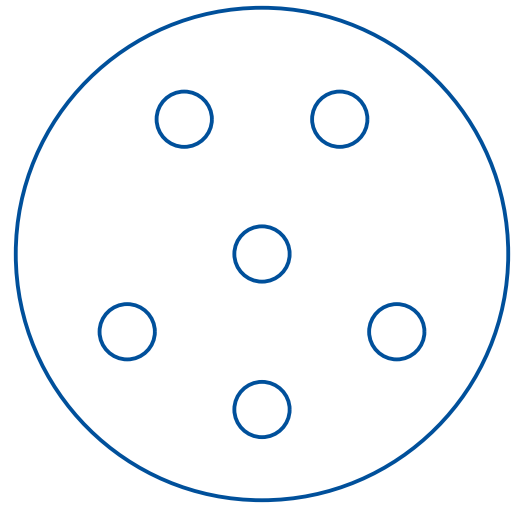

No. of Contacts	6
Contact Size	22D
Wire Size	28, 26, 24, 22

Shell Size	9
Arrangement	35
Service Rating	M
Test Current	5 AMPS

**NOTE:**  
 -DRAWING NOT TO SCALE  
 -DIMENSIONS SUBJECT TO CHANGE  
 -DIMENSIONS ARE IN INCHES [MM]

PROPERTY OF AMPHENOL AEROSPACE. ALL RIGHTS RESERVED.

<b>AMPHENOL CORPORATION</b> <small>40-60 DELAWARE AVENUE SIDNEY, N.Y. 13838</small>			
<b>RECEPTACLE</b> Electrical Connector TVPS00			<b>U</b>
<small>SIZE</small> <b>C</b>	<small>CAGE CODE</small> <b>77820</b>	<small>CODED NUMBER</small> <b>TVPS00DS-9-35P(P15)</b>	<small>REV</small> <b>X1</b>
SHEET 1 OF 1			