

# PRO-ELEC



**Infrared Motion Sensor  
Model: PELL0047  
and PELL0048**

**Please read these instructions carefully before use and retain for future reference.** This sensor must be installed by a qualified electrician in accordance with current building and IET wiring regulations (BS7671).

### **IMPORTANT SAFETY INFORMATION**

- This sensor is suitable for all lighting fittings (Class I or II).
- Check that the voltage indicated on the rating plate corresponds with that of the local network before connecting the appliance to the mains power supply.
- The sensor is suitable for connection to a 220-240V, 50Hz supply. It is designed for permanent connection to fixed wiring, which must be a suitable circuit protected by an RCD with an operating current not exceeding 30mA and an MCB or fuse of the correct rating.
- Avoid mounting the sensor close to heat sources such as heating vents.
- Avoid pointing the sensor toward objects that may move in wind.
- It is suitable for use in an ambient temperature between -20°C and +40°C.

### **WHAT'S INCLUDED**

- IR Sensor.
- User manual.
- Pack of screws and wall plugs.

### **POSITIONING**

- The sensor is suitable for mounting on plasterboard, wood or masonry surfaces.
- Do not install on damp or conductive surfaces such as metal. It should be placed away from any flammable materials.
- Before drilling any fixing holes, check that there are no hidden obstructions behind the mounting surface such as pipes or cables.

### **INSTALLATION**

- Ensure the mains supply is disconnected or isolated.
- Remove the screw in the centre of the front cover and lift off the cover.
- With regard to the location of the mains feed cable offer the sensor assembly to the wall and mark the position of the two mounting holes.
- Drill the wall where marked and fit the wall plugs then feed the supply and load wires through the grommet and attach the sensor assembly to the wall using the screws.

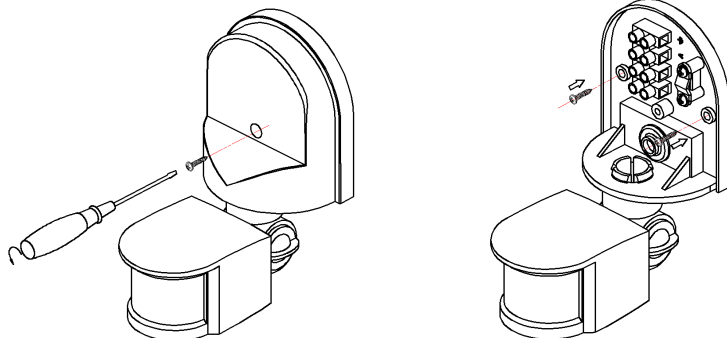

- Ensure the wires pass through the cable clamp and are correctly restrained.
- The supply and load wiring should be collected as follows:

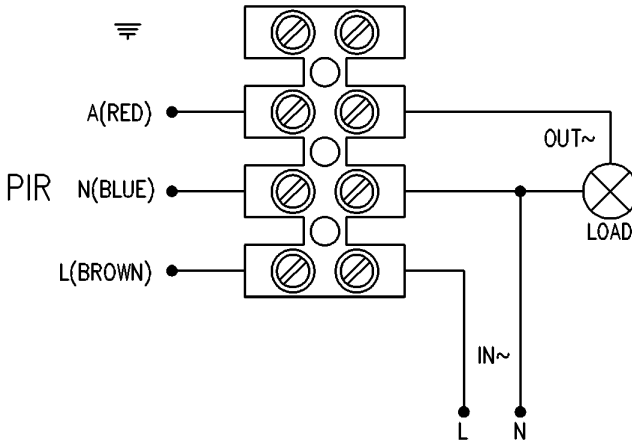

- When all wires are connected locate the terminal block onto the two pins on the back plate.

**Note:** If the load light fitting has a ground, connect the supply and the load ground wires using the spare connector in the terminal block.

- Replace the front cover and secure with the screw.
- Restore the power supply.

## OPERATION

- **Allow at least 30 sec for the sensor to initialise before making adjustments.**
- There are three adjustments on the bottom of the PIR sensor, one adjusts the duration (TIME) the load lighting remains lit, the second one is for the sensitivity of movement detection (SENS) and the third is to set the level of ambient light (LUX) before the sensor triggers the illumination.
- Some trial and error may be required to set these correctly.
- Adjust the SENS to alter the sensitivity/range of the motion detection.
- Adjust the TIME setting for the required duration you require the load light to remain illuminated.
- Adjust the LUX so the load light doesn't activate until the light level is low enough for lighting to be required.
- Turn the controls clockwise to increase the settings.

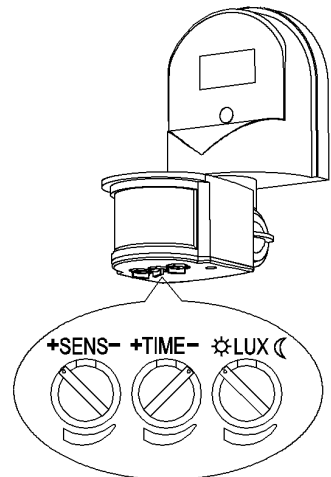

## CLEANING & MAINTENANCE

- Clean the sensor only with a soft dry cloth. Do not use any chemicals, abrasives or solvents that could damage the casing or lens.

## SPECIFICATION

<b>Input Voltage</b>	220 - 240V AC 50Hz
<b>Power consumption</b>	0.5W approx
<b>Ambient light</b>	<3 - 2000 Lux (adjustable)
<b>Time delay</b>	Min 10 sec / Max 7 min approx (adjustable)
<b>Rated load</b>	300W CF/LED ~ 1200W Incandescent
<b>Detection angle</b>	180°
<b>Detection range</b>	5 - 12m (adjustable)
<b>Installation height</b>	1.8 - 2.5m
<b>Ingress rating</b>	IP44

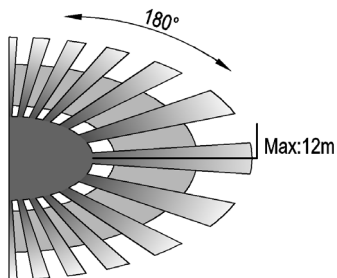
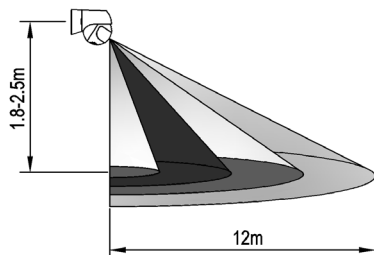

### INFORMATION ON WASTE DISPOSAL FOR CONSUMERS OF ELECTRICAL & ELECTRONIC EQUIPMENT.

When this product has reached the end of its life it must be treated as Waste Electrical & Electronic Equipment (WEEE). Any WEEE marked products must not be mixed with general household waste, but kept separate for the treatment, recovery and recycling of the materials used. Contact your local authority for details of recycling schemes in your area.



Made in China. PR2 9PP

Man Rev 1.0