

EUROPEAN 2-PIN PLUG-IN POWER SUPPLY 15VDC 7.5WATT POWERPAX: SW4313C



Features:

- European Fixed AC Head
- 1 Year Warranty
- Level VI Efficiency
- CE Approved

Description:

Our Range of Class II 7.5 Watt AC/DC European plug-in power supplies provide 7.5 Watts of continuous power in a compact fixed wall plug enclosure suitable for use in many general power applications.

Specification	
Part Number	SW4313C
Input Voltage Range	100-240Vac
Input Frequency Range	47-63Hz
Input Current Rated	0.4A Max
Output Voltage Rating	15V
Output Current Range	0.5A
Output Min Current	0.01A
Output Connection Type	2.1x5.5x12mm Centre Positive – Straight
Total Output Regulation	+/- 5%
Line and Load Regulation	+/- 5%
Ripple & Noise	150mVp-p
Efficiency	80.44%Min
Over Voltage Protection	16Vdc Max
Over Load Protection	1.4A
Operating Temperature	0°C to +50°C
Storage Temperature	-20°C to +80°C
Operating Humidity	10% to 90%
Storage Humidity	10% to 90%
Hi-Pot	3000Vac 5mA 1min
Leakage Current	0.25mA max
Safety Standard	Meet TUV (EN60950-1) Meet CE (Declared & CE Mark)
EMI Standard	FCC part 15: Class B EN55032, Class B EN 55024 EN 61000-4-2 EN 61000-4-3 EN 61000-4-4 EN 61000-4-5
MTBF	50,000 hours
Size mm max.	78.98(L) x 41 (W) x 49.2(H)
Weight	110 g
Regulator Type	Switched Mode Power Supply

General Note

TT Electronics reserves the right to make changes in product specification without notice or liability. All information is subject to TT Electronics' own data and is considered accurate at time of going to print.

POWERPAX

TT Electronics IoT Solutions Ltd
Tofts Farm East, Brenda Road, Hartlepool, TS25 2BQ, UK
t: +44 (0) 1429 852 500

EUROPEAN 2-PIN PLUG-IN POWER SUPPLY 15VDC 7.5WATT POWERPAX: SW4313C

Diagrams

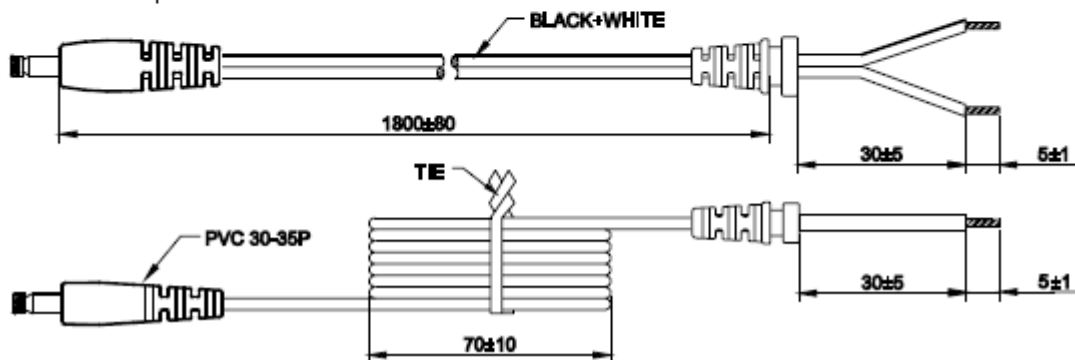
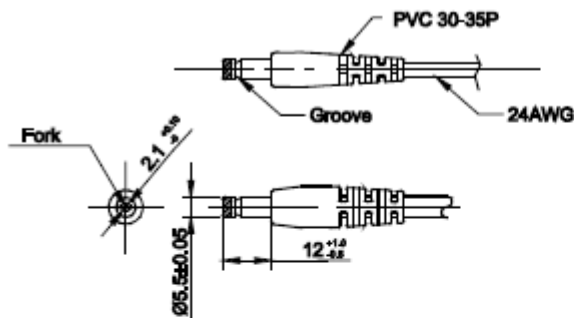
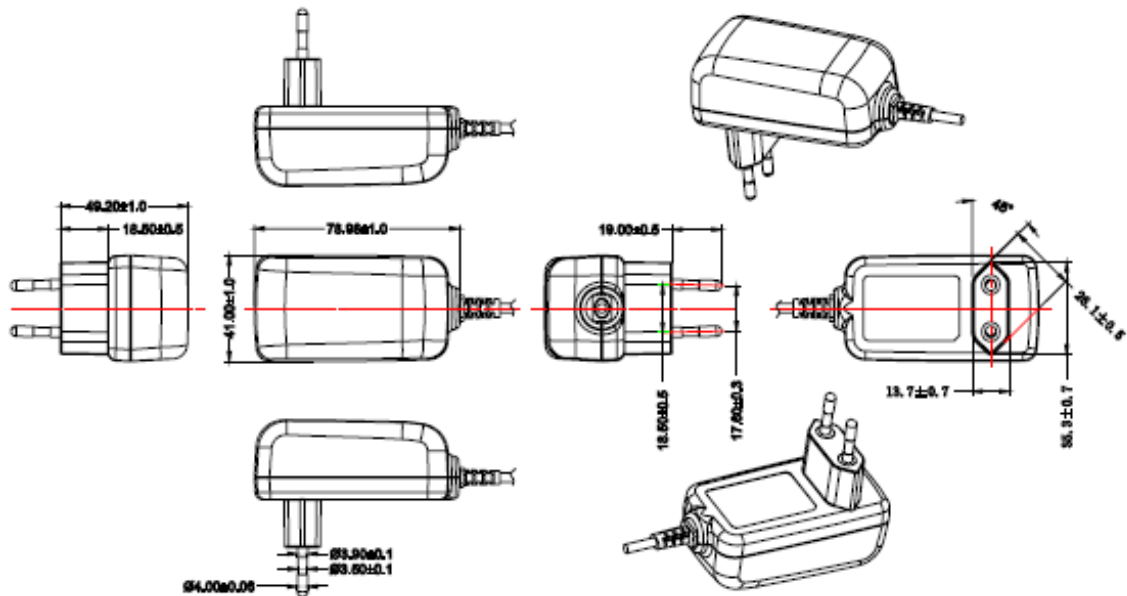

General Note

TT Electronics reserves the right to make changes in product specification without notice or liability. All information is subject to TT Electronics' own data and is considered accurate at time of going to print.

POWERPAX

TT Electronics IoT Solutions Ltd
Tofts Farm East, Brenda Road, Hartlepool, TS25 2BQ, UK
t: +44 (0) 1429 852 500