

COMMENT: ALL RIGHTS ARE RESERVED BY US FOR THIS DRAWING. WITHOUT OUR PRIOR CONSENT, IT MAY NEITHER BE DUPLICATED NOR MADE AVAILABLE TO A THIRD PARTY. AND IT ALSO MAY NOT BE IMPROPERLY USED BY THE RECEIVER, OR A THIRD PARTY.

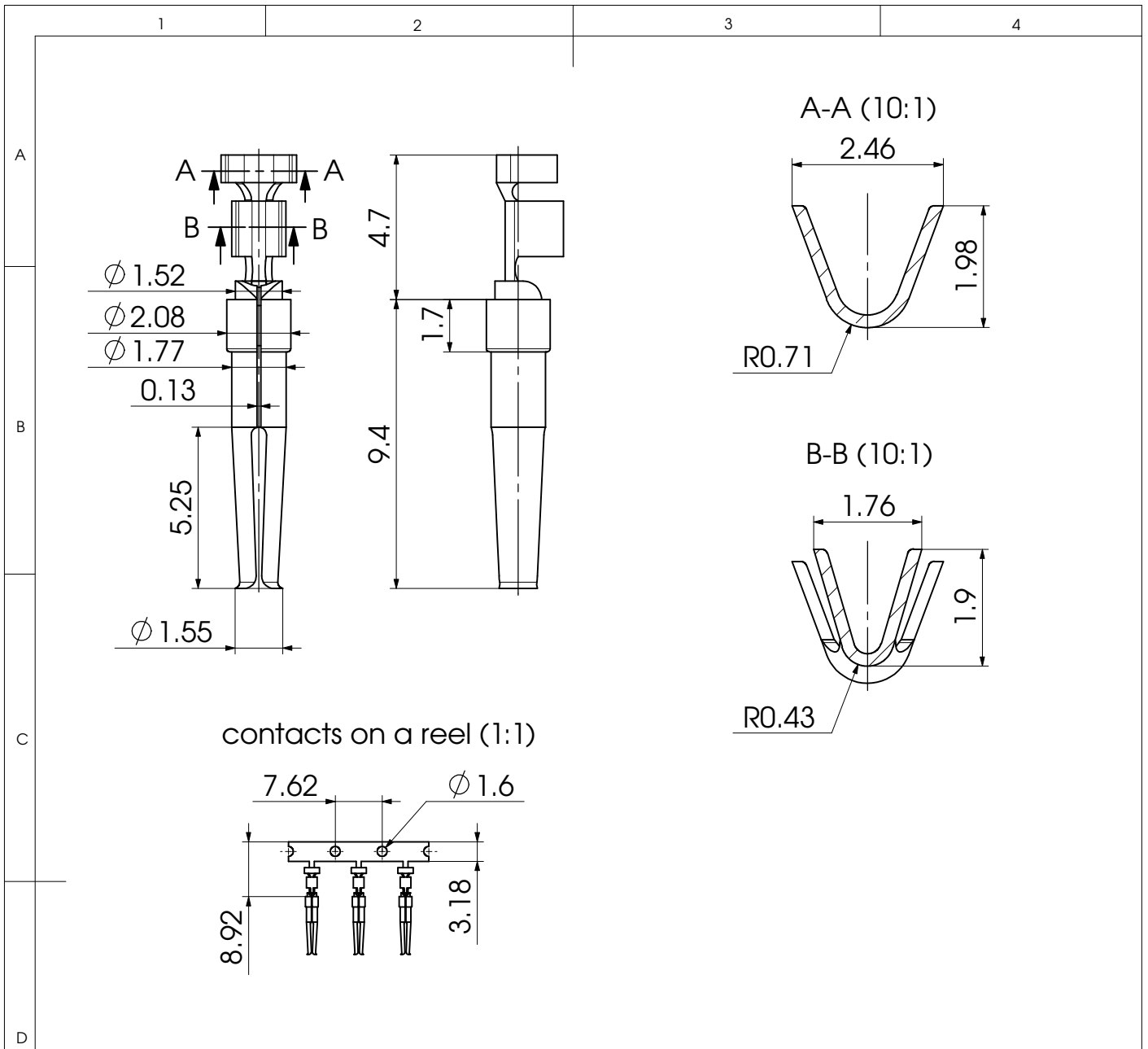

E	20-24	0,1µm Au over Ni (Copper alloy)	S7L	10 strips of 25 pieces in a box
			S7LR	10,000 pieces on a reel
			S7LR-V2	10,000 pieces on a reel / Entry from Left Side with Turn Round
			S7LR-V3	10,000 pieces on a reel / Entry from Left Side
			S7L-K1459	500 pieces individually packed in bags
	20-24	0,8µm Au over Ni (Copper alloy)	S7L-K176	10 strips of 25 pieces in a box
			S7LR-K176	10,000 pieces on a reel
			S7LR-K176V2	10,000 pieces on a reel / Entry from Left Side with Turn Round
			S7LR-K176V3	10,000 pieces on a reel / Entry from Left Side
	20-24	1,2µm Au over Ni (Copper alloy)	S7LSR-K176	350 pieces on a reel
			S7LR-K1592	10,000 pieces on a reel
			S7LR-K1592V2	10,000 pieces on a reel / Entry from Left Side with Turn Round
Wire Size AWG	Surface (Material)	Part No.	Packing Unit	

				Measurement without tolerance occ. to ISO 2768-m	SCALE 10:1	TITLE Crimp contacts, stamped for wire size 20-24AWG
			DRAWN	NAME / DATE ADenzinger 25-01-2008		
			CHECKED	SKusber 08-02-2008		
			 fctgroup.com		DWG.NO.	S7L_D
1	25-01-2008	22194				REV. 1
REV.	DATE	CH.-NO.	ORIGINAL: DIN A4-DRAWING AS A FILE	REPLACEMENT FOR:	S7L_D α	PAGES 1