

100 V VB 3.5 A/4.5 A Peak Current

High Frequency High-Side and Low-Side Driver

BD2320EFJ-LA

General Description

This product guarantees long time support in industrial market.

BD2320EFJ-LA is the 100 V maximum voltage High-Side and Low-Side gate driver which can drive external Nch-FET using the bootstrap method. The driver includes a 100 V bootstrap diode and independent inputs control for High-Side and Low-Side. 3.3 V and 5.0 V are available for interface voltage. Under Voltage Lockout circuits are built in for High-Side and Low-Side.

Features

- Long Time Support Product for Industrial Applications.
- Under Voltage Lockout (UVLO) for High-Side and Low-Side Driver
- 3.3 V and 5.0 V Interface Voltage
- Output In-phase with Input Signal

Applications

- Power Supplies for Telecom and Datacom.
- MOSFET Application
- Half-bridge and Full-bridge Converters
- Forward Converters

Key Specification

- High-Side Supply Voltage and Floating Voltage: 100 V
- Output Voltage Range: 7.5 V to 14.5 V
- Output Current I_{o+}/I_{o-} : 3.5 A/4.5 A
- Propagation Delay: 27 ns (Typ)
- Delay Matching: 12 ns (Max)
- Offset Voltage Pin Leak Current: 10 μ A (Max)
- Operating Temperature Range: -40 °C to +125 °C

Package

HTSOP-J8

W (Typ) x D (Typ) x H (Max)
4.9 mm x 6.0 mm x 1.0 mm

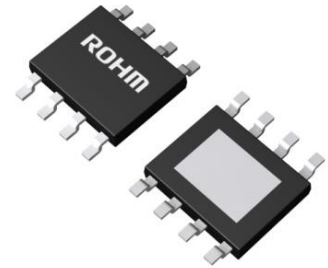

Typical Application Circuit

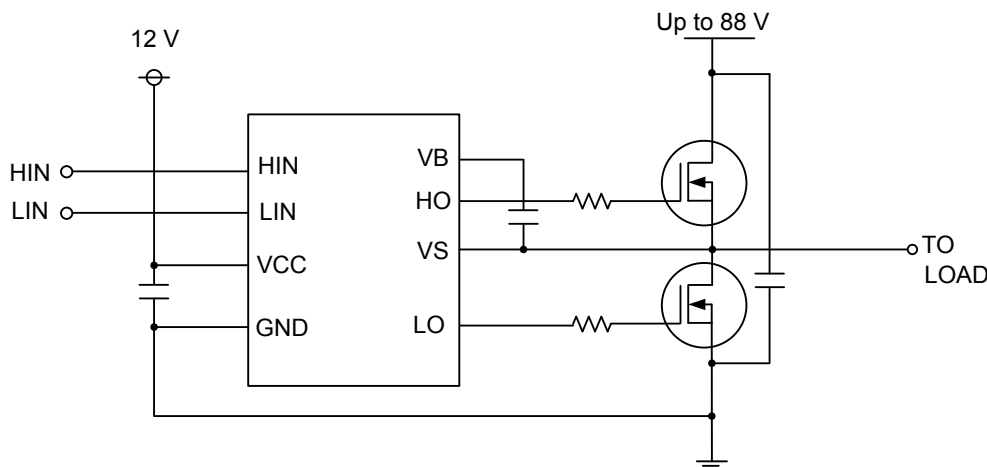

○Product structure : Silicon integrated circuit ○This product has no designed protection against radioactive rays.

Pin Configuration

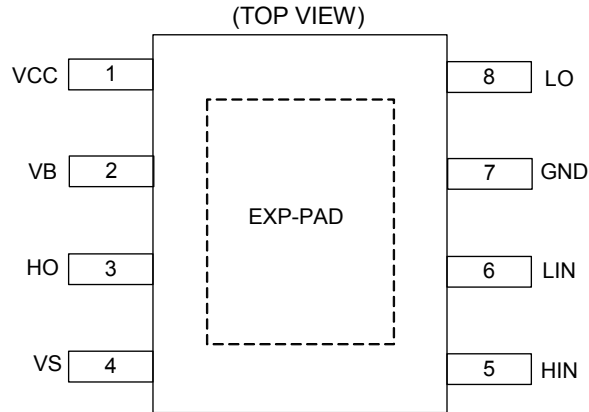

Pin Description

Pin No.	Pin Name	Function
1	VCC	Low-Side supply voltage
2	VB	High-Side supply voltage
3	HO	High-Side output
4	VS	High-Side return
5	HIN	Logic input for High-Side
6	LIN	Logic input for Low-Side
7	GND	Ground
8	LO	Low-Side output
-	EXP-PAD	Connect to GND

Block Diagram

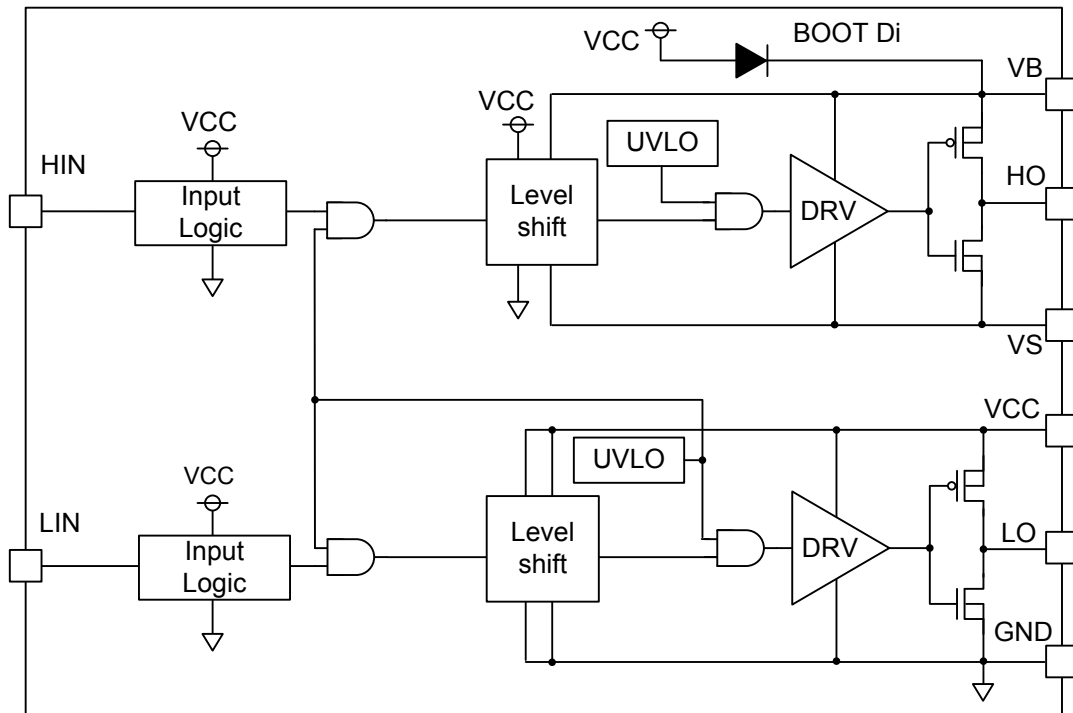

Absolute Maximum Rating (Ta = 25 °C)

Parameter	Symbol	Rating	Unit
VB - VS Voltage	V _{BS}	-0.3 to +15	V
Voltage on VB	V _{VB}	-0.3 to +100	V
Voltage on VS	V _{VS}	-15 to +100	V
Voltage on HO	V _{HO}	V _{VS} -0.3 to V _{VB} +0.3	V
V _{CC} Voltage	V _{CC}	-0.3 to +15	V
Voltage on LO	V _{LO}	-0.3 to V _{CC} +0.3	V
Voltage on HIN and LIN	V _{HIN} , V _{LIN}	-0.3 to V _{CC} +0.3	V
Voltage Slew Rate on VB, VS	SR	-50 to +50	V/ns
Maximum Junction Temperature	T _{jmax}	150	°C
Storage Temperature Range	T _{stg}	-55 to +150	°C

Caution 1: Operating the IC over the absolute maximum ratings may damage the IC. The damage can either be a short circuit between pins or an open circuit between pins and the internal circuitry. Therefore, it is important to consider circuit protection measures, such as adding a fuse, in case the IC is operated over the absolute maximum ratings.

Caution 2: Should by any chance the maximum junction temperature rating be exceeded the rise in temperature of the chip may result in deterioration of the properties of the chip. In case of exceeding this absolute maximum rating, design a PCB with thermal resistance taken into consideration by increasing board size and copper area so as not to exceed the maximum junction temperature rating.

Thermal Resistance (Note 1)

Parameter	Symbol	Thermal Resistance (Typ)		Unit
		1s ^(Note 3)	2s2p ^(Note 4)	
HTSOP-J8				
Junction to Ambient	θ _{JA}	206.4	45.2	°C/W
Junction to Top Characterization Parameter ^(Note 2)	Ψ _{JT}	21	13	°C/W

(Note 1) Based on JESD51-2A (Still-Air).

(Note 2) The thermal characterization parameter to report the difference between junction temperature and the temperature at the top center of the outside surface of the component package.

(Note 3) Using a PCB board based on JESD51-3.

(Note 4) Using a PCB board based on JESD51-5, 7.

Layer Number of Measurement Board	Material	Board Size
Single	FR-4	114.3 mm x 76.2 mm x 1.57 mmt

Top	
Copper Pattern	Thickness
Footprints and Traces	70 μm

Layer Number of Measurement Board	Material	Board Size	Thermal Via ^(Note 5)	
			Pitch	Diameter
4 Layers	FR-4	114.3 mm x 76.2 mm x 1.6 mmt	1.20 mm	Φ0.30 mm

Top		2 Internal Layers		Bottom	
Copper Pattern	Thickness	Copper Pattern	Thickness	Copper Pattern	Thickness
Footprints and Traces	70 μm	74.2 mm x 74.2 mm	35 μm	74.2 mm x 74.2 mm	70 μm

(Note 5) This thermal via connects with the copper pattern of all layers.

Recommended Operating Conditions

Parameter	Symbol	Min	Typ	Max	Unit
Operating Temperature	Topr	-40	+25	+125	°C
Voltage on VB	V _{VB}	-0.3	-	+95	V
Voltage on VS	V _{VS}	-7.0	-	+95	V
VB - VS Voltage	V _{BS}	7.0	-	14.5	V
Voltage on HIN LIN	V _{HIN} , V _{LIN}	0	-	V _{CC}	V
V _{CC} Voltage	V _{CC}	7.5	-	14.5	V

Electrical Characteristics (Unless otherwise specified Ta = -40 °C to +125 °C, V_{CC} = 12.0 V, V_{BS} = 12.0 V, V_{VS} = V_{GND}, HO = open, LO = open)

Parameter	Symbol	Min	Typ	Max	Unit	Conditions
Circuit Current						
Offset supply Leakage Current	I _{LK}	-	0	10	μA	V _{VB} = V _{VS} = 100 V
Quiescent V _{BS} Supply Current	I _{QBS}	40	80	160	μA	V _{LIN} = V _{HIN} = 0 V
Operating V _{BS} Supply Current	I _{OBS}	2.75	5.50	11.00	mA	f = 500 kHz
Quiescent V _{CC} Supply Current	I _{QCC}	60	120	240	μA	V _{LIN} = V _{HIN} = 0 V
Operating V _{CC} Supply Current	I _{OCC}	3.00	6.00	12.00	mA	f = 500 kHz
UVLO						
V _{CC} UVLO Rising Threshold	V _{CCUVR}	4.6	6.0	7.4	V	
V _{CC} UVLO Falling Threshold	V _{CCUVF}	4.2	5.5	6.8	V	
V _{CC} UVLO Hysteresis	V _{CCUVH}	-	0.5	-	V	
V _{BS} UVLO Rising Threshold	V _{BSUVR}	4.1	5.4	6.7	V	
V _{BS} UVLO Falling Threshold	V _{BSUVF}	3.7	4.9	6.1	V	
V _{BS} UVLO Hysteresis	V _{BSUVH}	-	0.5	-	V	
Input						
Logic "1" Input Threshold Voltage	V _{IH}	1.50	2.15	2.80	V	
Logic "0" Input Threshold Voltage	V _{IL}	0.80	1.25	1.70	V	
Input Threshold Hysteresis	V _{INHYS}	0.3	0.9	-	V	
Input Pulldown Resistance	R _{IN}	50	100	150	kΩ	
Output						
High Level Output Voltage, V _{CC} - V _{LO} , V _{VB} - V _{HO}	V _{OH}	-	16	-	mV	V _{CC} = 12 V, V _{VB} = 12 V, V _{VS} = 0 V, I _O = 10 mA
Low Level Output Voltage, V _{LO} - GND, V _{HO} - V _{VS}	V _{OL}	-	8	-	mV	V _{CC} = 12 V, V _{VB} = 12 V, V _{VS} = 0 V, I _O = 10 mA
Output High Short Circuit Pulse Current ^(Note 6)	I _{O+}	-	3.5	-	A	V _{LO} , V _{HO} = 0 V
Output Low Short Circuit Pulse Current ^(Note 6)	I _{O-}	-	4.5	-	A	V _{LO} , V _{HO} = 12 V
Bootstrap Diode						
Bootstrap Diode Forward Voltage1	V _{F1}	0.26	0.53	1.16	V	I _{VCC-VB} = 100 μA
Bootstrap Diode Forward Voltage2	V _{F2}	0.95	1.90	3.80	V	I _{VCC-VB} = 100 mA
Bootstrap Diode Dynamic Resistance	R _D	5.0	10.0	20.0	Ω	I _{VCC-VB} = 80 mA, 100 mA

(Note 6) Not 100 % tested.

Electrical Characteristics - continued

(Unless otherwise specified Ta = -40 °C to +125 °C, V_{CC} = 12.0 V, V_{BS} = 12.0 V, V_{VS} = V_{GND}, HO = open, LO = open)

Parameter	Symbol	Min	Typ	Max	Unit	Conditions
HO Turn-on Propagation Delay	t _{ONH}	10	27	50	ns	
LO Turn-on Propagation Delay	t _{ONL}	10	27	50		
HO Turn-off Propagation Delay	t _{OFFH}	10	29	50		
LO Turn-off Propagation Delay	t _{OFFL}	10	29	50		
HO Turn-on Rise Time	t _{RH}	-	8	-		HO = 1 nF
LO Turn-on Rise Time	t _{RL}	-	8	-		LO = 1 nF
HO Turn-off Fall Time	t _{FH}	-	6	-		HO = 1 nF
LO Turn-off Fall Time	t _{FL}	-	6	-		LO = 1 nF
Delay Matching, HS Turn-off, LS Turn-on	t _{M1}	-	2.0	12		
Delay Matching, HS Turn-on, LS Turn-off	t _{M2}	-	2.0	12		

Typical Performance (Reference Data)

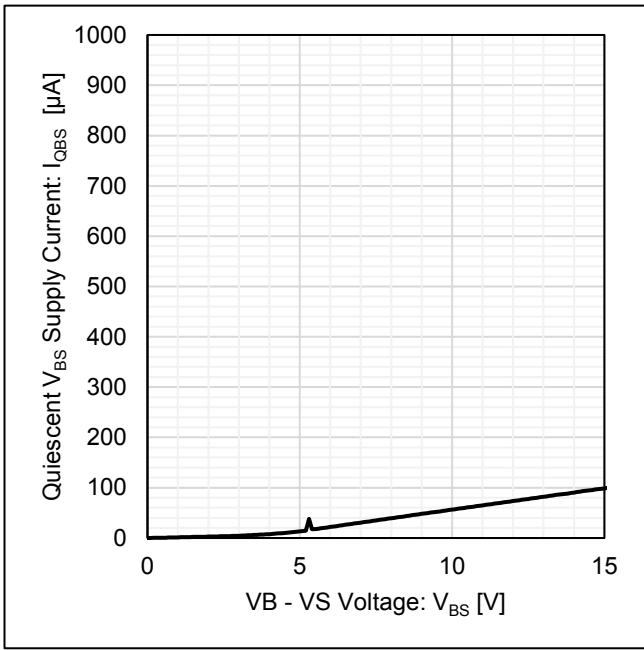

Figure 2. Quiescent V_{BS} Supply Current vs $V_B - V_S$ Voltage

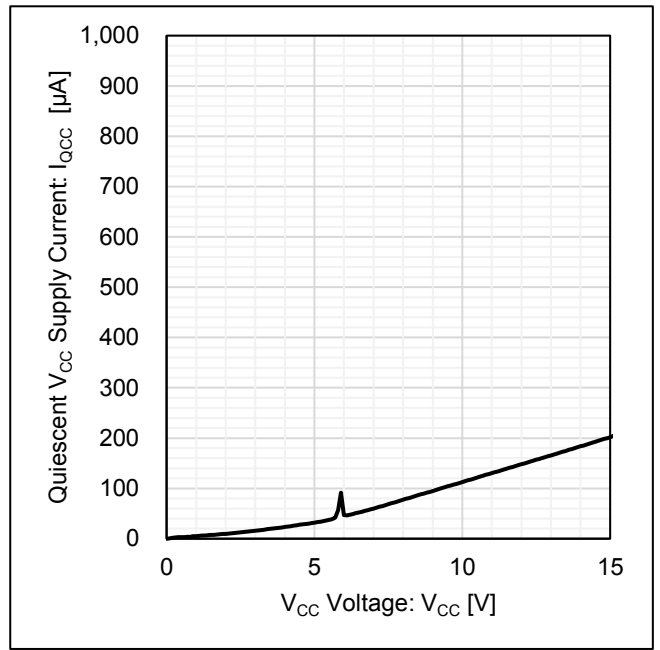

Figure 3. Quiescent V_{CC} Supply Current vs V_{CC} Voltage

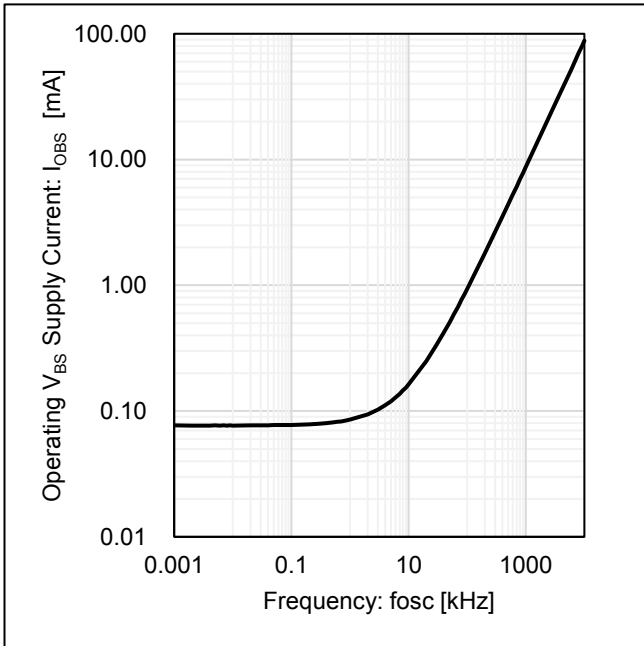

Figure 4. Operating V_{BS} Supply Current vs Frequency

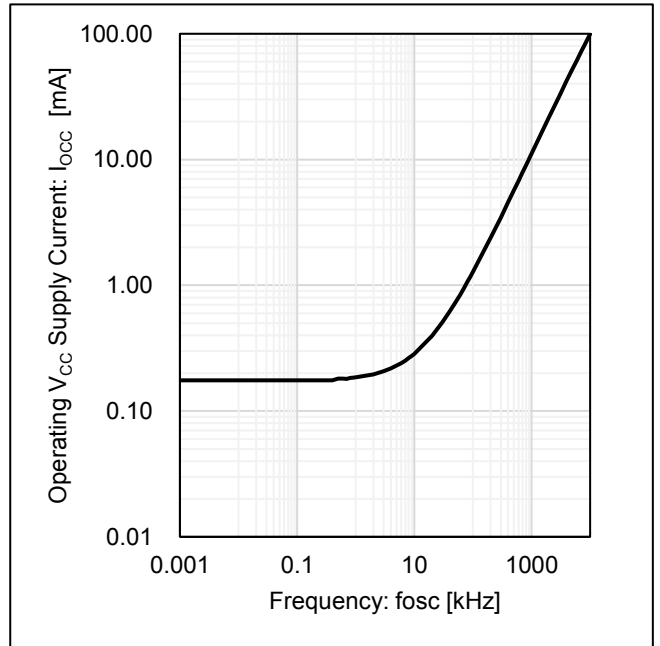

Figure 5. Operating V_{CC} Supply Current vs Frequency

Typical Performance (Reference Data) -continued

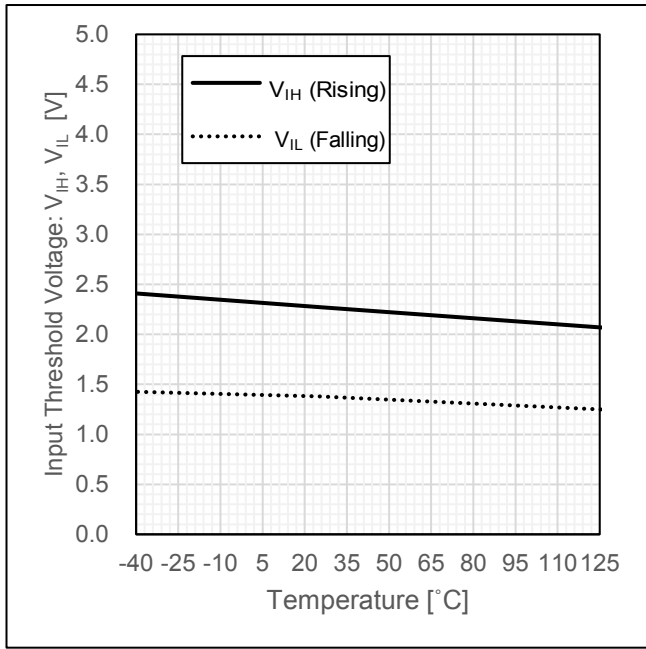

Figure 6. Input Threshold Voltage vs Temperature

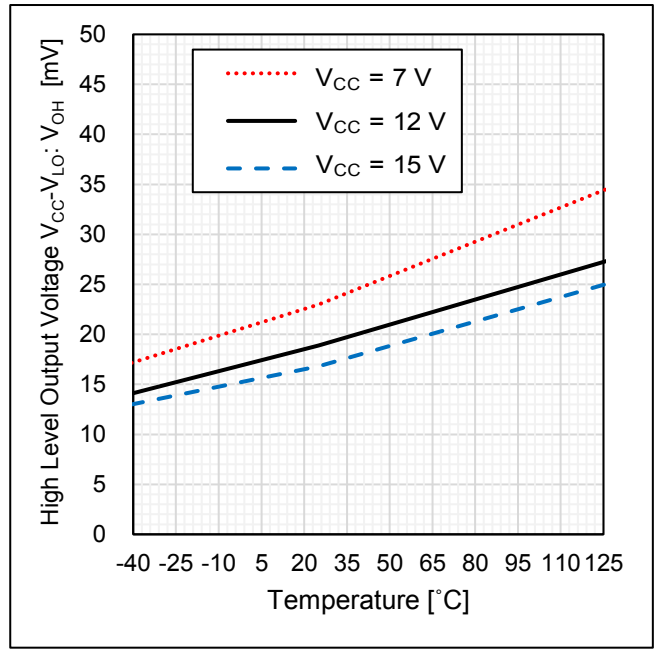

Figure 7. High Level Output Voltage V_{CC} - V_{LO} vs Temperature

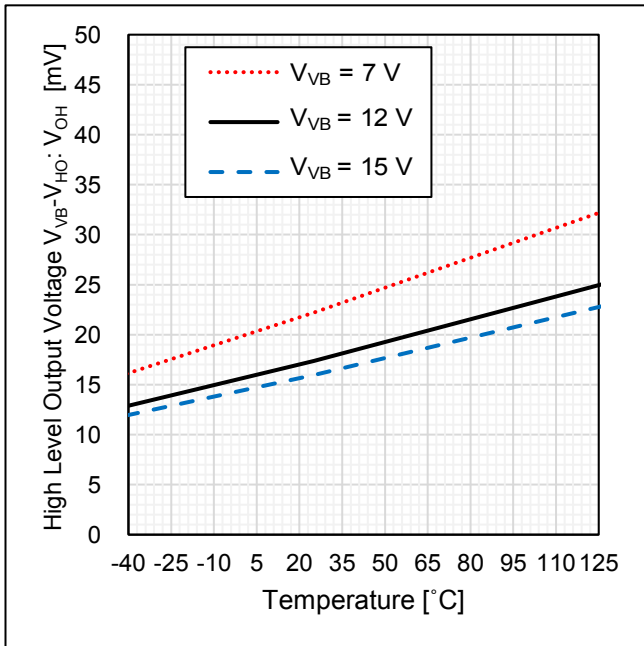

Figure 8. High Level Output Voltage V_{VB} - V_{HO} vs Temperature

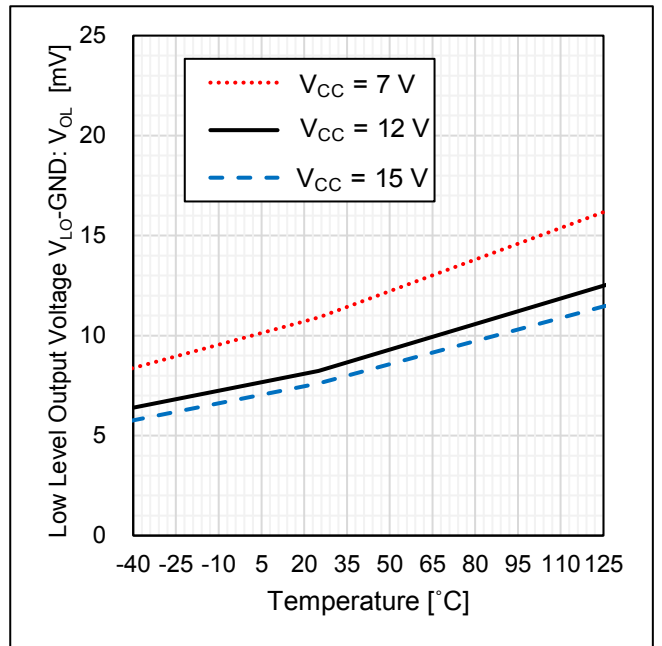

Figure 9. Low Level Output Voltage V_{LO} - GND vs Temperature

Typical Performance (Reference Data) -continued

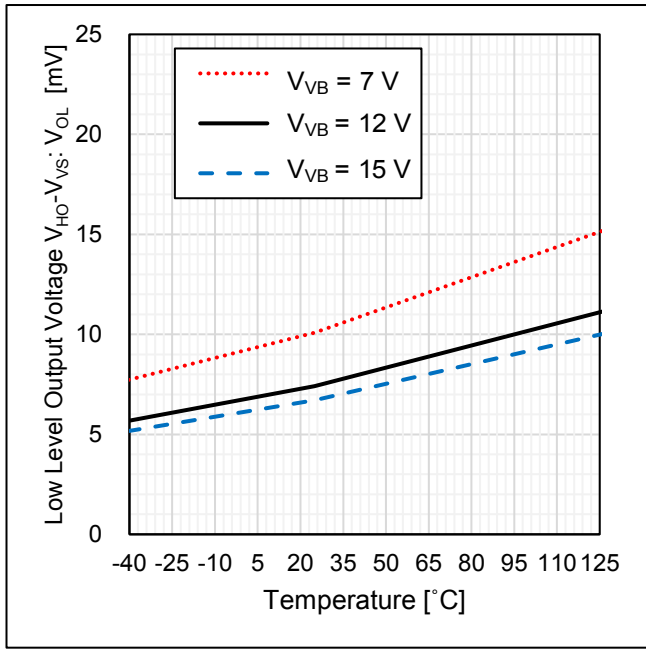

Figure 10. Low Level Output Voltage $V_{HO} - V_{VS}$ vs Temperature

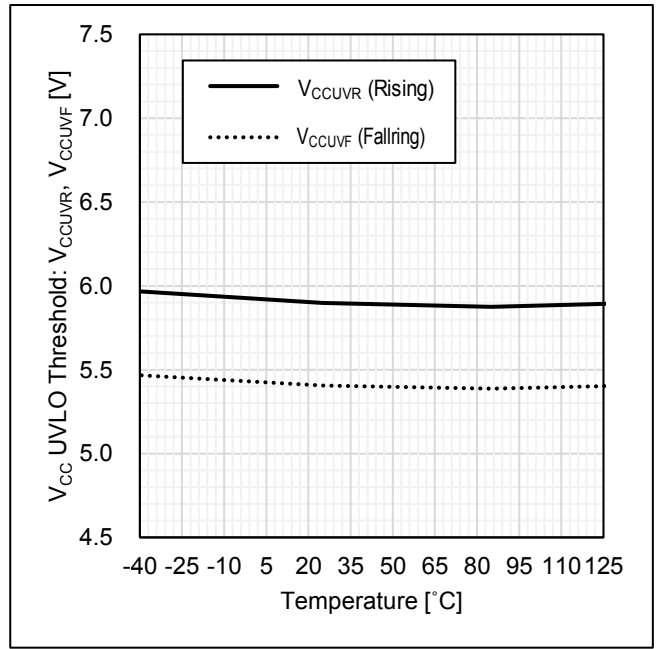

Figure 11. V_{CC} UVLO Threshold vs Temperature

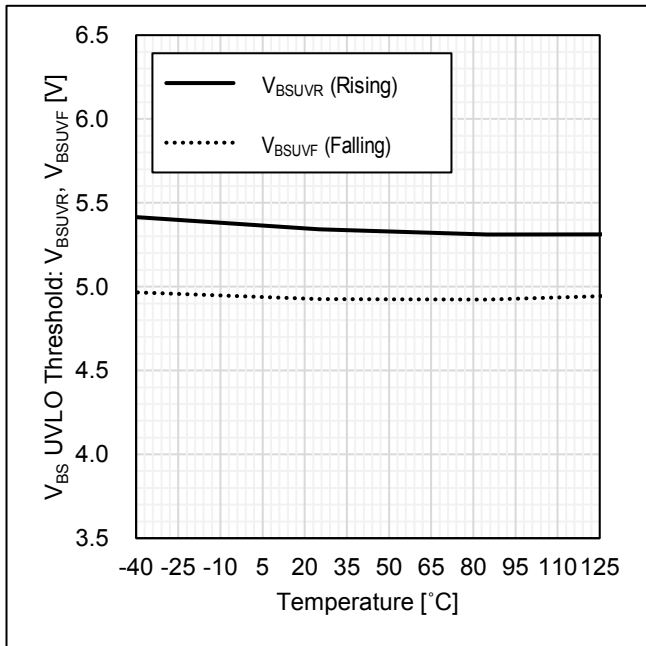

Figure 12. V_{BS} UVLO Threshold vs Temperature

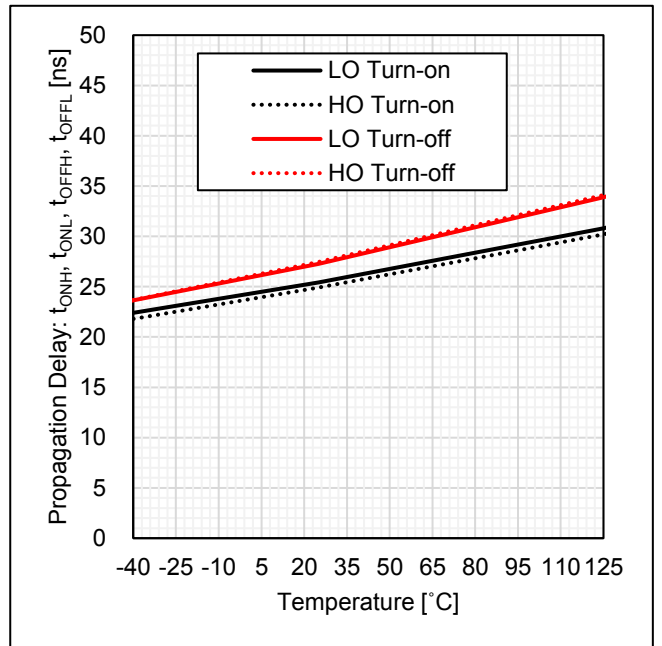

Figure 13. Propagation Delay vs Temperature

Typical Performance (Reference Data) -continued

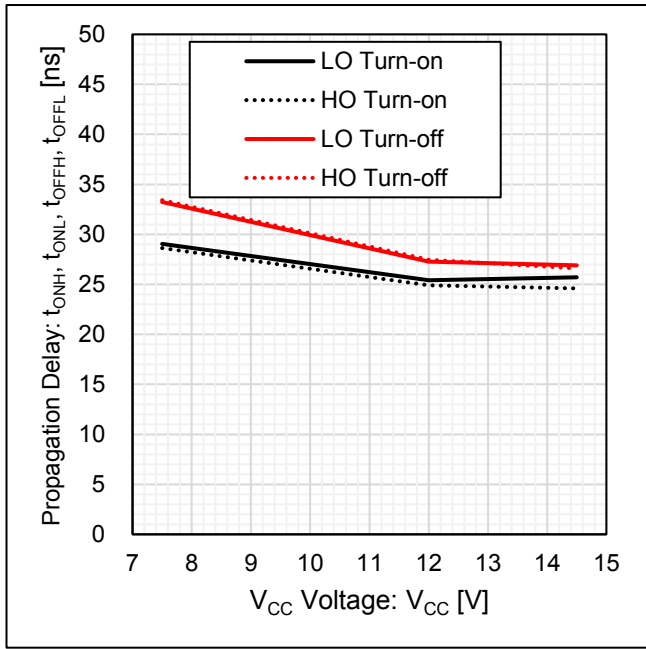

Figure 14. Propagation Delay vs V_{CC} Voltage

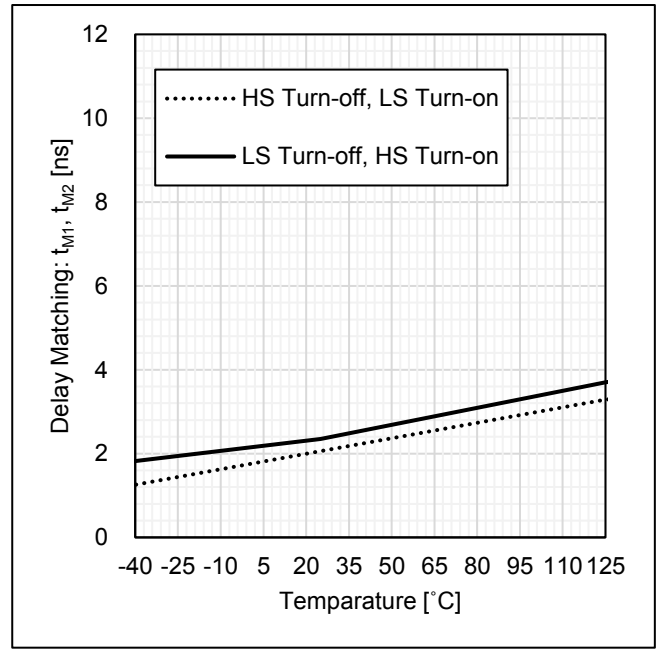

Figure 15. Delay Matching vs Temperature

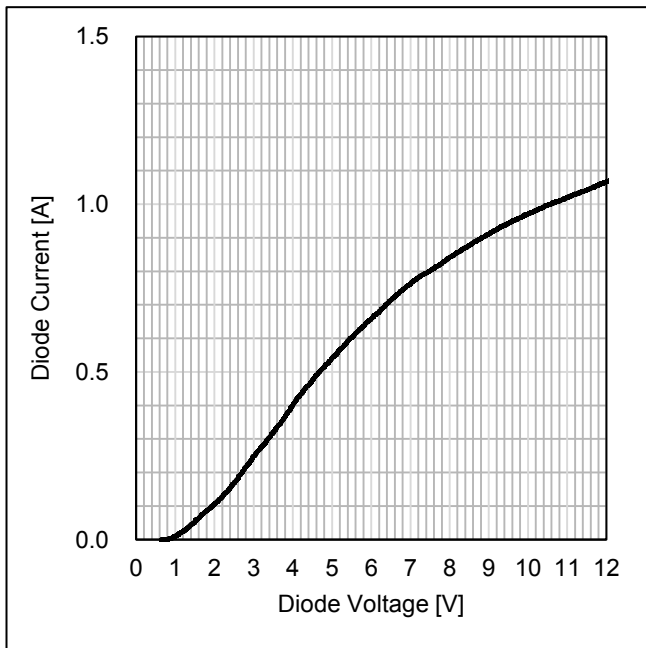

Figure 16. Diode Current vs Diode Voltage

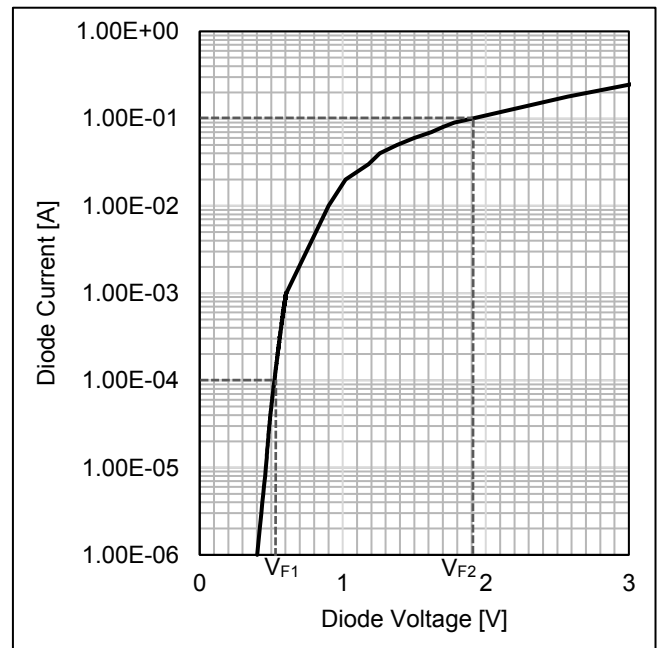
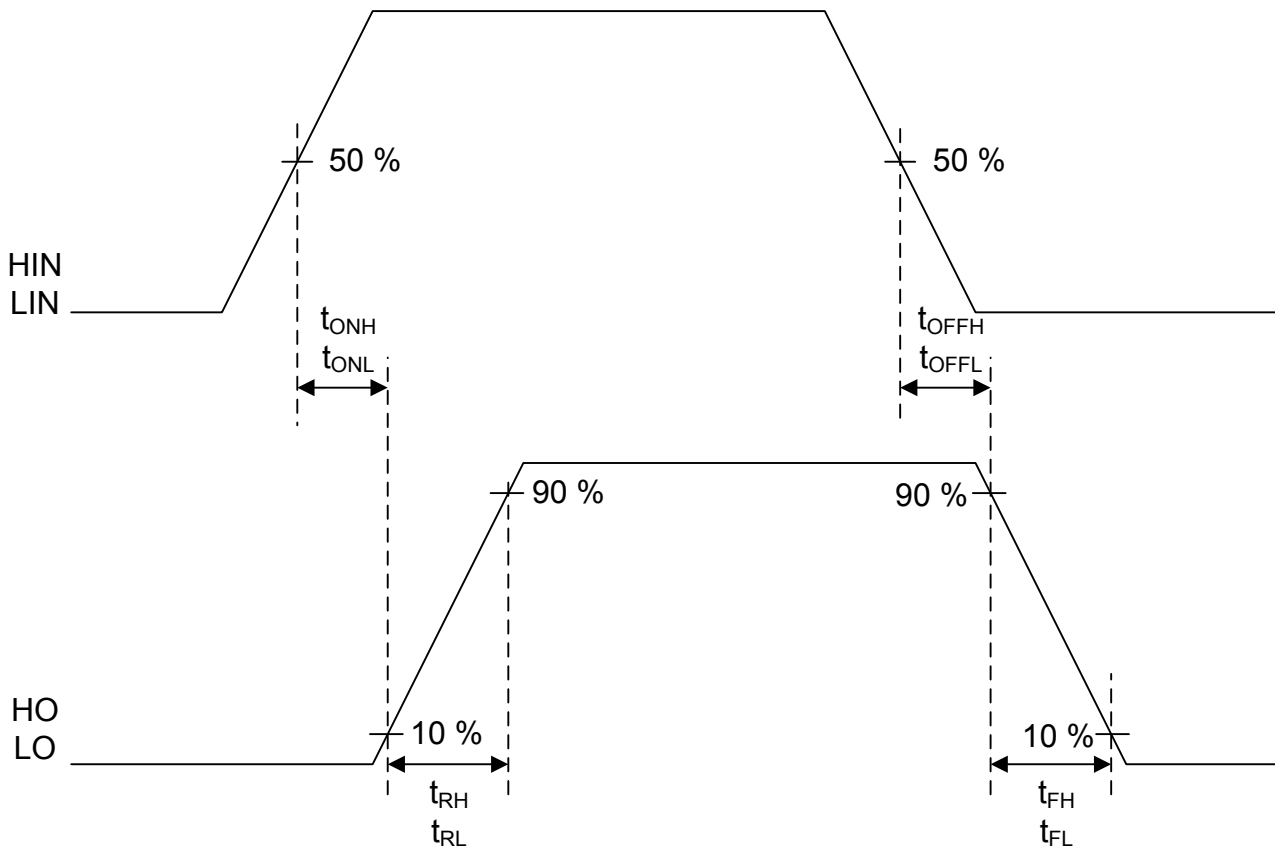

Figure 17. Diode Current vs Diode Voltage (V_{F1}, V_{F2})

Timing Chart



Selection of Components Externally Connected

1. Gate Resistor

The gate resistor $R_{G(ON)}$, $R_{G(OFF)}$ can be selected to control the switching speed of the external FET. The turn on time (t_{SW}) is decided by the gate resistor, gate-to-source charge (Q_{GS}) and gate-to-drain charge (Q_{GD}) of the external FET. In mean current flowing to a gate of the external FET is calculated as follows.

$$I_G = \frac{Q_{GS}+Q_{GD}}{t_{SW}} \tag{1}$$

The turn on gate resistor is calculated as follows.

$$R_{TOTAL(ON)} = R_{ONP} + R_{G(ON)} = \frac{V_{CC}-V_{GS}}{I_G} \tag{2}$$

The turn on time is calculated as follows.

$$t_{SW} = \frac{Q_{GS}+Q_{GD}}{I_G} = \frac{(Q_{GS}+Q_{GD})(R_{ONP}+R_{G(ON)})}{(V_{BS}-V_{GS(th)})} \tag{3}$$

The switching slew rate of the external FET (dVs/dt) also can be controlled by the gate resistor. The switching slew rate of the external FET (dVs/dt) is calculated as follows.

$$\frac{dVs}{dt} = \frac{I_G}{C_{RSS}} \tag{4}$$

where:

C_{RSS} is the feedback capacitance.

Substituting equation (4) into equation (2) yields the following formulas.

$$R_{TOTAL(ON)} = R_{ONP} + R_{G(ON)} = \frac{V_{BS}-V_{GS(th)}}{C_{RSS} \frac{dVs}{dt}} \tag{5}$$

$$R_{G(ON)} = \frac{V_{BS}-V_{GS(th)}}{C_{RSS} \frac{dVs}{dt}} - R_{ONP} \tag{6}$$

When the gate driver output turns off, current flows to gate resistor through C_{GD} of the external FET. To prevent that the gate voltage of the external FET becomes higher than the threshold voltage and the external FET self-turn-on, please set up the turn off resistor ($R_{G(OFF)}$) that satisfies the following formulas.

$$V_{GS(th)} \geq I_G (R_{ONN} + R_{G(OFF)}) = C_{GD} \frac{dVs}{dt} (R_{ONN} + R_{G(OFF)}) \tag{7}$$

$$R_{G(OFF)} \geq \frac{V_{GS(th)}}{C_{GD} \frac{dVs}{dt}} - R_{ONN} \tag{8}$$

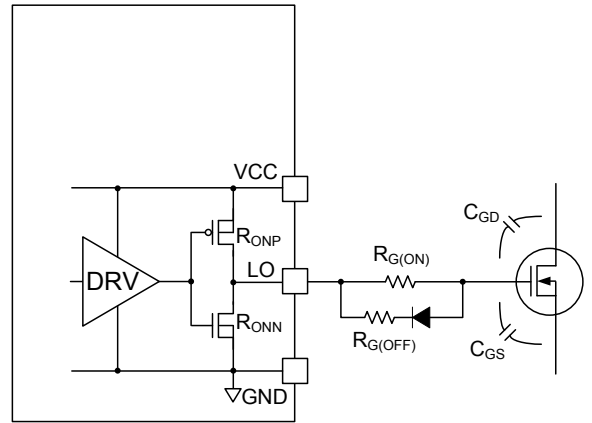

Figure 18. Gate Driver Equivalent Circuit

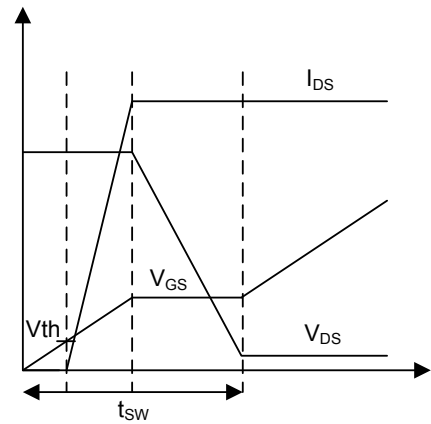

Figure 19. Gate Charge Transfer Characteristics

Selection of Components Externally Connected -continued

2. Bootstrap Capacitor C_{BS}

To reduce ripple voltage, ceramic capacitors with low ESR value are recommended for use in the bootstrap circuit. The maximum voltage drop (ΔV_{BS}) that we have to guarantee when the high-side external FET is in on state must be:

$$\Delta V_{BS} \leq VCC - VF - V_{BSUVR} - V_{OL} \quad (9)$$

where:

VCC is the gate driver supply voltage,

VF is the forward voltage drop of the bootstrap diode

V_{BSUVR} is the V_{BS} UVLO release voltage

V_{OL} is Drain-source voltage of Low side external FET device

The total charge supplied (Q_{TOTAL}) by the bootstrap capacitor is calculated by following formula.

$$Q_{TOTAL} = Q_G + (I_{LKGS} + I_{LKDIO} + I_{QBS})t_{HON} \quad (10)$$

where

Q_G is the total gate charge of external FET,

I_{LKGS} is the gate-source leakage current of external FET,

I_{LKDIO} is the bootstrap diode leakage current,

I_{QBS} is the high-side quiescent current,

t_{HON} is the high-side switch on time.

The bootstrap capacitor value should satisfy the following formula.

$$C_{BS} \geq \frac{Q_{TOTAL}}{\Delta V_{BS}} \quad (11)$$

It is not able to keep being turned on the high side in the same way as the high side switch driver because of the specifications of the bootstrap circuits.

3. Input Capacitor

Mount a low-ESR ceramic input capacitor near the VCC pin to reduce input ripple.

For VCC capacitor, it is recommended to use a ceramic capacitor which has a value of two times or larger than that of the boot strap capacitor.

I/O Equivalence Circuits

Pin No.	Pin Name	Pin Equivalence Circuit	Pin No.	Pin Name	Pin Equivalence Circuit
1	VCC		5	HIN	
2, 4	VB, VS		6	LIN	
3	HO		8	LO	

Operational Notes

1. Reverse Connection of Power Supply

Connecting the power supply in reverse polarity can damage the IC. Take precautions against reverse polarity when connecting the power supply, such as mounting an external diode between the power supply and the IC's power supply pins.

2. Power Supply Lines

Design the PCB layout pattern to provide low impedance supply lines. Furthermore, connect a capacitor to ground at all power supply pins. Consider the effect of temperature and aging on the capacitance value when using electrolytic capacitors.

3. Ground Voltage

Ensure that no pins are at a voltage below that of the ground pin at any time, even during transient condition.

4. Ground Wiring Pattern

When using both small-signal and large-current ground traces, the two ground traces should be routed separately but connected to a single ground at the reference point of the application board to avoid fluctuations in the small-signal ground caused by large currents. Also ensure that the ground traces of external components do not cause variations on the ground voltage. The ground lines must be as short and thick as possible to reduce line impedance.

5. Recommended Operating Conditions

The function and operation of the IC are guaranteed within the range specified by the recommended operating conditions. The characteristic values are guaranteed only under the conditions of each item specified by the electrical characteristics.

6. Inrush Current

When power is first supplied to the IC, it is possible that the internal logic may be unstable and inrush current may flow instantaneously due to the internal powering sequence and delays, especially if the IC has more than one power supply. Therefore, give special consideration to power coupling capacitance, power wiring, width of ground wiring, and routing of connections.

7. Testing on Application Boards

When testing the IC on an application board, connecting a capacitor directly to a low-impedance output pin may subject the IC to stress. Always discharge capacitors completely after each process or step. The IC's power supply should always be turned off completely before connecting or removing it from the test setup during the inspection process. To prevent damage from static discharge, ground the IC during assembly and use similar precautions during transport and storage.

8. Inter-pin Short and Mounting Errors

Ensure that the direction and position are correct when mounting the IC on the PCB. Incorrect mounting may result in damaging the IC. Avoid nearby pins being shorted to each other especially to ground, power supply and output pin. Inter-pin shorts could be due to many reasons such as metal particles, water droplets (in very humid environment) and unintentional solder bridge deposited in between pins during assembly to name a few.

9. Unused Input Pins

Input pins of an IC are often connected to the gate of a MOS transistor. The gate has extremely high impedance and extremely low capacitance. If left unconnected, the electric field from the outside can easily charge it. The small charge acquired in this way is enough to produce a significant effect on the conduction through the transistor and cause unexpected operation of the IC. So unless otherwise specified, unused input pins should be connected to the power supply or ground line.

Operational Notes – continued

10. Regarding the Input Pin of the IC

This monolithic IC contains P+ isolation and P substrate layers between adjacent elements in order to keep them isolated. P-N junctions are formed at the intersection of the P layers with the N layers of other elements, creating a parasitic diode or transistor. For example (refer to figure below):

When $GND > Pin A$ and $GND > Pin B$, the P-N junction operates as a parasitic diode.

When $GND > Pin B$, the P-N junction operates as a parasitic transistor.

Parasitic diodes inevitably occur in the structure of the IC. The operation of parasitic diodes can result in mutual interference among circuits, operational faults, or physical damage. Therefore, conditions that cause these diodes to operate, such as applying a voltage lower than the GND voltage to an input pin (and thus to the P substrate) should be avoided.

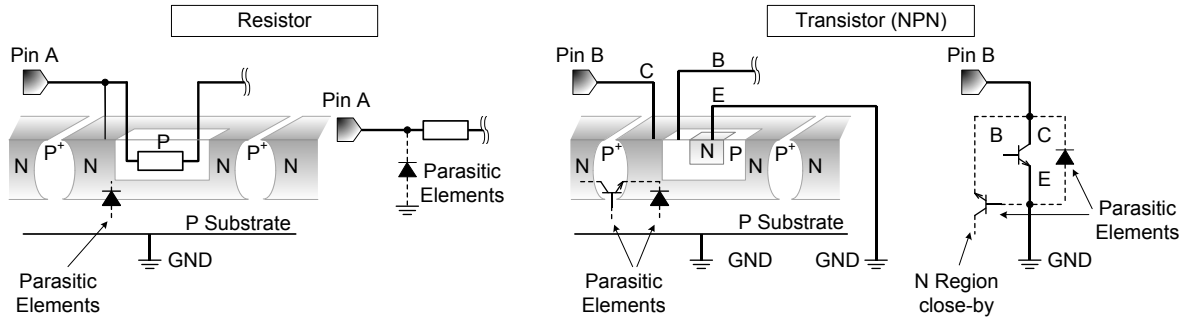
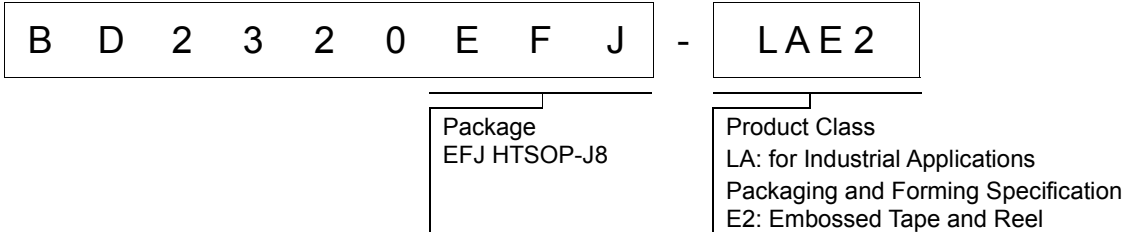

Figure 20. Example of Monolithic IC Structure

11. Ceramic Capacitor

When using a ceramic capacitor, determine a capacitance value considering the change of capacitance with temperature and the decrease in nominal capacitance due to DC bias and others.

Ordering Information



Marking Diagram

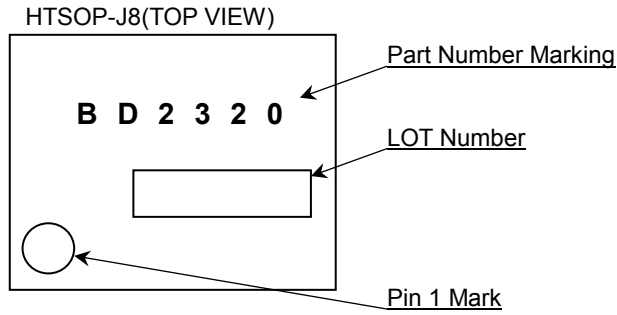

Physical Dimension and Packing Information

Package Name	HTSOP-J8
--------------	----------

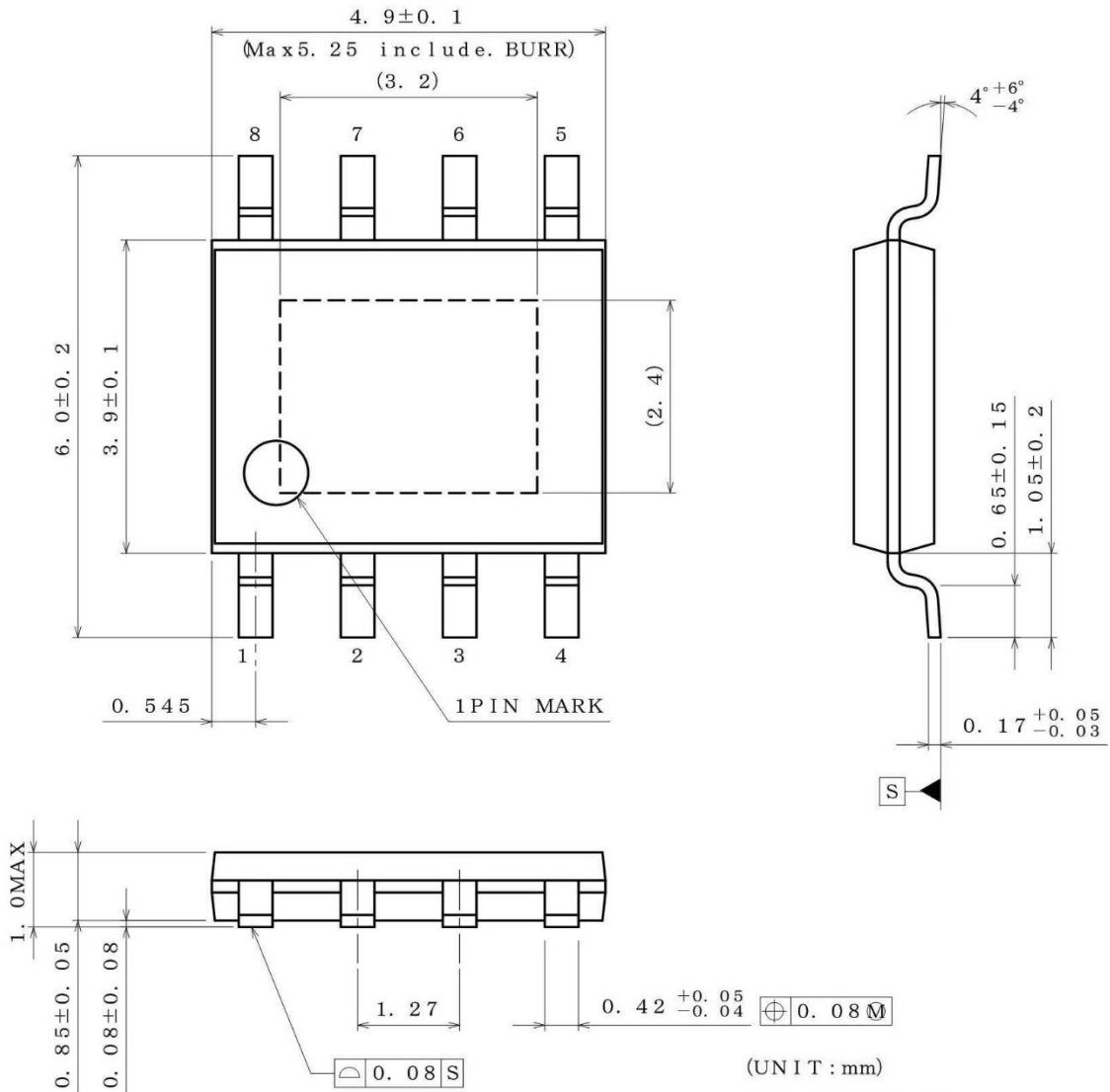

(UNIT : mm)
 PKG : HTSOP-J8
 Drawing No. EX169-5002-2

< Tape and Reel Information >

Tape	Embossed carrier tape
Quantity	2500pcs
Direction of feed	E2 The direction is the pin 1 of product is at the upper left when you hold reel on the left hand and you pull out the tape on the right hand

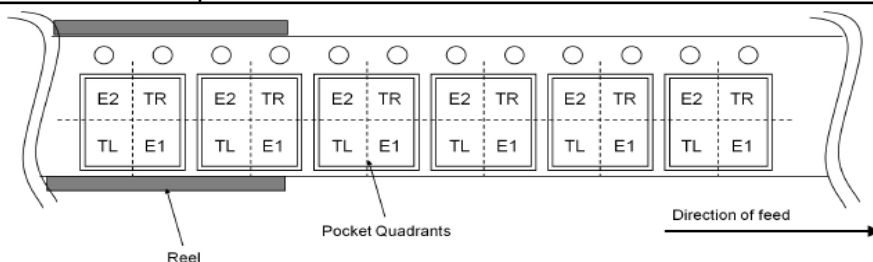

Revision History

Date	Revision	Changes
04.Dec.2020	001	New Release

Notice

Precaution on using ROHM Products

1. If you intend to use our Products in devices requiring extremely high reliability (such as medical equipment ^(Note 1), aircraft/spacecraft, nuclear power controllers, etc.) and whose malfunction or failure may cause loss of human life, bodily injury or serious damage to property ("Specific Applications"), please consult with the ROHM sales representative in advance. Unless otherwise agreed in writing by ROHM in advance, ROHM shall not be in any way responsible or liable for any damages, expenses or losses incurred by you or third parties arising from the use of any ROHM's Products for Specific Applications.

(Note1) Medical Equipment Classification of the Specific Applications

JAPAN	USA	EU	CHINA
CLASS III	CLASS III	CLASS II b	CLASS III
CLASS IV		CLASS III	

2. ROHM designs and manufactures its Products subject to strict quality control system. However, semiconductor products can fail or malfunction at a certain rate. Please be sure to implement, at your own responsibilities, adequate safety measures including but not limited to fail-safe design against the physical injury, damage to any property, which a failure or malfunction of our Products may cause. The following are examples of safety measures:
 - [a] Installation of protection circuits or other protective devices to improve system safety
 - [b] Installation of redundant circuits to reduce the impact of single or multiple circuit failure
3. Our Products are not designed under any special or extraordinary environments or conditions, as exemplified below. Accordingly, ROHM shall not be in any way responsible or liable for any damages, expenses or losses arising from the use of any ROHM's Products under any special or extraordinary environments or conditions. If you intend to use our Products under any special or extraordinary environments or conditions (as exemplified below), your independent verification and confirmation of product performance, reliability, etc. prior to use, must be necessary:
 - [a] Use of our Products in any types of liquid, including water, oils, chemicals, and organic solvents
 - [b] Use of our Products outdoors or in places where the Products are exposed to direct sunlight or dust
 - [c] Use of our Products in places where the Products are exposed to sea wind or corrosive gases, including Cl₂, H₂S, NH₃, SO₂, and NO₂
 - [d] Use of our Products in places where the Products are exposed to static electricity or electromagnetic waves
 - [e] Use of our Products in proximity to heat-producing components, plastic cords, or other flammable items
 - [f] Sealing or coating our Products with resin or other coating materials
 - [g] Use of our Products without cleaning residue of flux (Exclude cases where no-clean type fluxes is used. However, recommend sufficiently about the residue.); or Washing our Products by using water or water-soluble cleaning agents for cleaning residue after soldering
 - [h] Use of the Products in places subject to dew condensation
4. The Products are not subject to radiation-proof design.
5. Please verify and confirm characteristics of the final or mounted products in using the Products.
6. In particular, if a transient load (a large amount of load applied in a short period of time, such as pulse, is applied, confirmation of performance characteristics after on-board mounting is strongly recommended. Avoid applying power exceeding normal rated power; exceeding the power rating under steady-state loading condition may negatively affect product performance and reliability.
7. De-rate Power Dissipation depending on ambient temperature. When used in sealed area, confirm that it is the use in the range that does not exceed the maximum junction temperature.
8. Confirm that operation temperature is within the specified range described in the product specification.
9. ROHM shall not be in any way responsible or liable for failure induced under deviant condition from what is defined in this document.

Precaution for Mounting / Circuit board design

1. When a highly active halogenous (chlorine, bromine, etc.) flux is used, the residue of flux may negatively affect product performance and reliability.
2. In principle, the reflow soldering method must be used on a surface-mount products, the flow soldering method must be used on a through hole mount products. If the flow soldering method is preferred on a surface-mount products, please consult with the ROHM representative in advance.

For details, please refer to ROHM Mounting specification

Precautions Regarding Application Examples and External Circuits

1. If change is made to the constant of an external circuit, please allow a sufficient margin considering variations of the characteristics of the Products and external components, including transient characteristics, as well as static characteristics.
2. You agree that application notes, reference designs, and associated data and information contained in this document are presented only as guidance for Products use. Therefore, in case you use such information, you are solely responsible for it and you must exercise your own independent verification and judgment in the use of such information contained in this document. ROHM shall not be in any way responsible or liable for any damages, expenses or losses incurred by you or third parties arising from the use of such information.

Precaution for Electrostatic

This Product is electrostatic sensitive product, which may be damaged due to electrostatic discharge. Please take proper caution in your manufacturing process and storage so that voltage exceeding the Products maximum rating will not be applied to Products. Please take special care under dry condition (e.g. Grounding of human body / equipment / solder iron, isolation from charged objects, setting of Ionizer, friction prevention and temperature / humidity control).

Precaution for Storage / Transportation

1. Product performance and soldered connections may deteriorate if the Products are stored in the places where:
 - [a] the Products are exposed to sea winds or corrosive gases, including Cl₂, H₂S, NH₃, SO₂, and NO₂
 - [b] the temperature or humidity exceeds those recommended by ROHM
 - [c] the Products are exposed to direct sunshine or condensation
 - [d] the Products are exposed to high Electrostatic
2. Even under ROHM recommended storage condition, solderability of products out of recommended storage time period may be degraded. It is strongly recommended to confirm solderability before using Products of which storage time is exceeding the recommended storage time period.
3. Store / transport cartons in the correct direction, which is indicated on a carton with a symbol. Otherwise bent leads may occur due to excessive stress applied when dropping of a carton.
4. Use Products within the specified time after opening a humidity barrier bag. Baking is required before using Products of which storage time is exceeding the recommended storage time period.

Precaution for Product Label

A two-dimensional barcode printed on ROHM Products label is for ROHM's internal use only.

Precaution for Disposition

When disposing Products please dispose them properly using an authorized industry waste company.

Precaution for Foreign Exchange and Foreign Trade act

Since concerned goods might be fallen under listed items of export control prescribed by Foreign exchange and Foreign trade act, please consult with ROHM in case of export.

Precaution Regarding Intellectual Property Rights

1. All information and data including but not limited to application example contained in this document is for reference only. ROHM does not warrant that foregoing information or data will not infringe any intellectual property rights or any other rights of any third party regarding such information or data.
2. ROHM shall not have any obligations where the claims, actions or demands arising from the combination of the Products with other articles such as components, circuits, systems or external equipment (including software).
3. No license, expressly or implied, is granted hereby under any intellectual property rights or other rights of ROHM or any third parties with respect to the Products or the information contained in this document. Provided, however, that ROHM will not assert its intellectual property rights or other rights against you or your customers to the extent necessary to manufacture or sell products containing the Products, subject to the terms and conditions herein.

Other Precaution

1. This document may not be reprinted or reproduced, in whole or in part, without prior written consent of ROHM.
2. The Products may not be disassembled, converted, modified, reproduced or otherwise changed without prior written consent of ROHM.
3. In no event shall you use in any way whatsoever the Products and the related technical information contained in the Products or this document for any military purposes, including but not limited to, the development of mass-destruction weapons.
4. The proper names of companies or products described in this document are trademarks or registered trademarks of ROHM, its affiliated companies or third parties.

General Precaution

1. Before you use our Products, you are requested to carefully read this document and fully understand its contents. ROHM shall not be in any way responsible or liable for failure, malfunction or accident arising from the use of any ROHM's Products against warning, caution or note contained in this document.
2. All information contained in this document is current as of the issuing date and subject to change without any prior notice. Before purchasing or using ROHM's Products, please confirm the latest information with a ROHM sales representative.
3. The information contained in this document is provided on an "as is" basis and ROHM does not warrant that all information contained in this document is accurate and/or error-free. ROHM shall not be in any way responsible or liable for any damages, expenses or losses incurred by you or third parties resulting from inaccuracy or errors of or concerning such information.