

CB-100 I/O CONNECTOR BLOCK

This installation guide describes how to connect the CB-100 I/O connector block to your data acquisition (DAQ) board.

Introduction

With the CB-100 I/O connector block, you can easily connect external signals to the National Instruments DAQ boards. When used with a ribbon cable, the CB-100 is a low-cost, ribbon-cable alternative to a shielded connection scheme. The CB-100 I/O connector block is available with an R1005050 or NB5 ribbon cable.

With an R1005050 ribbon cable, the CB-100 can connect to devices that use a 100-pin female 50-mil D-type connector. These devices include the PCI-DIO-96 and PXI-6508 digital I/O boards, the PCI-6025E and PCI-6071E multifunction I/O boards, and most other 100-pin DAQ boards from National Instruments.

With an NB5 ribbon cable, the CB-100 can connect to the PC-DIO-96 digital I/O board.

The CB-100 kit consists of a 1.0 m R1005050 or NB5 ribbon cable assembly and two connector blocks with 50 screw terminals each. The cable assembly has two 50-pin cables and three connectors. The cables are joined to a single 100-pin connector on one end and two 50-pin connectors on the free ends. Each cable connects to 50 pins of the 100-pin connector and has a label identifying those pins. For connector pinout information, see your DAQ board user manual. The 50-pin connectors have a centered tab that you must align with the slot on the mating header on the connector block.

What You Need to Get Started

You need the following to install your CB-100:

- CB-100 kit:
 - 1.0 m R1005050 or NB5 cable assembly
 - Interface assembly
 - Connector blocks
 - Ejector ears
 - Flush-mount brackets
 - Rail-mount brackets
 - Screwdriver
 - *CB-100 I/O Connector Block Installation Guide*

If your kit is missing any of the components, contact National Instruments.

Installation



Caution

Although the connectors are keyed, it is possible to force the connectors into the header the wrong way. You must be absolutely certain that the connectors are properly aligned. Failure to do so could cause signals to be connected to the wrong pins, which could damage the DAQ board and the computer. National Instruments is NOT liable for damage resulting from such connections.

1. Plug the 100-pin connector into the 100-pin rear panel connector on the board.

Figure 1 shows the connection from the R1005050 ribbon cable to a 100-pin DAQ device.

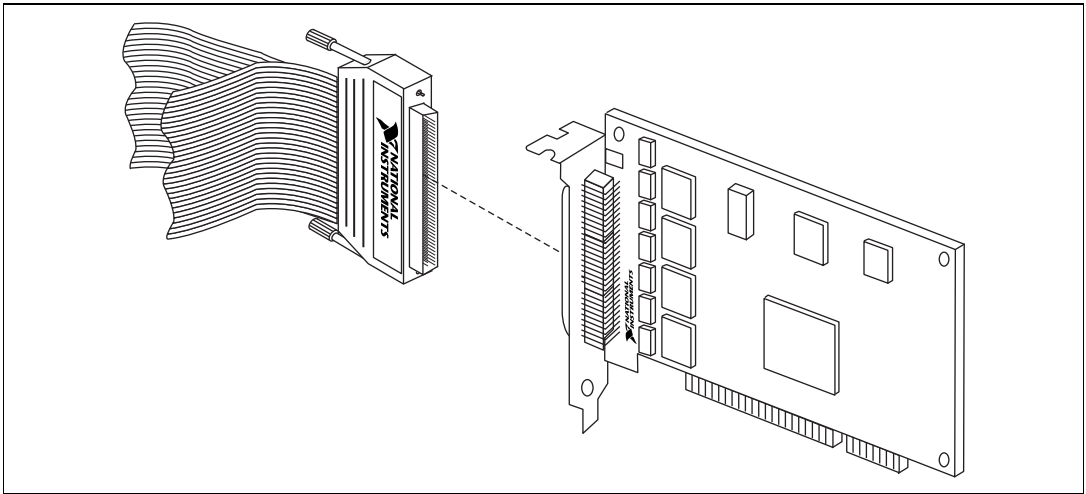

Figure 1. Connecting the R1005050 Ribbon Cable

Figure 2 shows the connection from the NB5 ribbon cable to the PC-DIO-96.

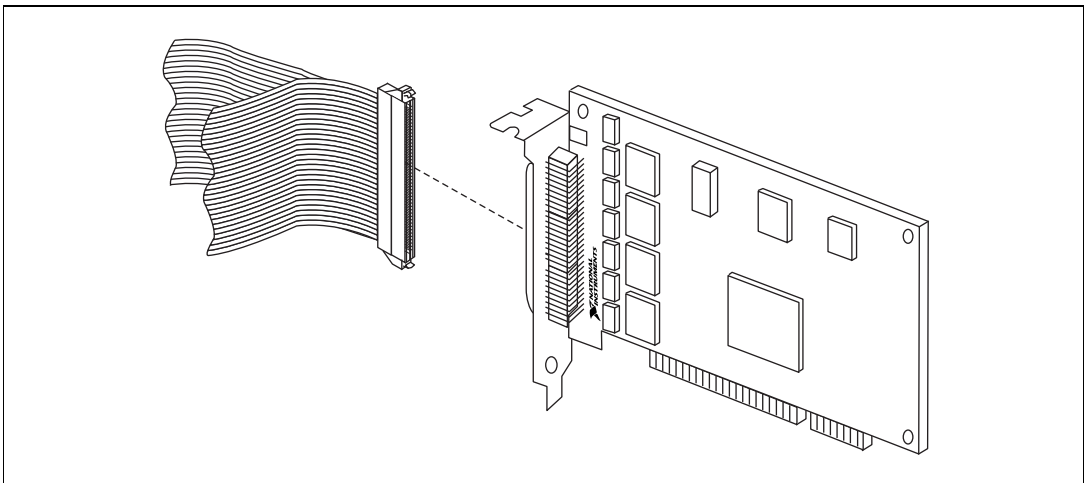

Figure 2. Connecting the NB5 Ribbon Cable

2. Firmly push in the connector for proper contact.
3. Insert one pair of the ejector ears into each connector block as shown in Figure 3.

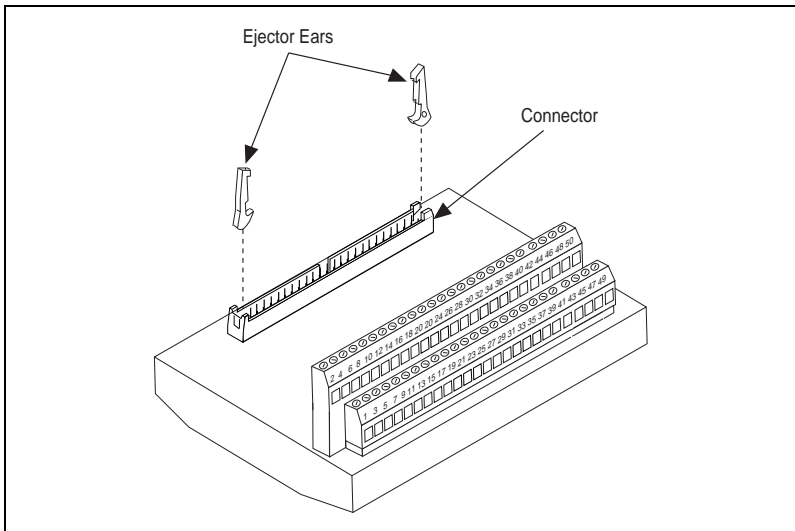

Figure 3. Inserting the Ejector Ears into the Connector Block

4. If you plan to mount your connector blocks for stability, choose one of the following procedures for mounting. If you do not want to mount your connector blocks, proceed to step 6.
 - For flush mounting, insert the flush-mount brackets into the connector block base as shown in Figure 4.

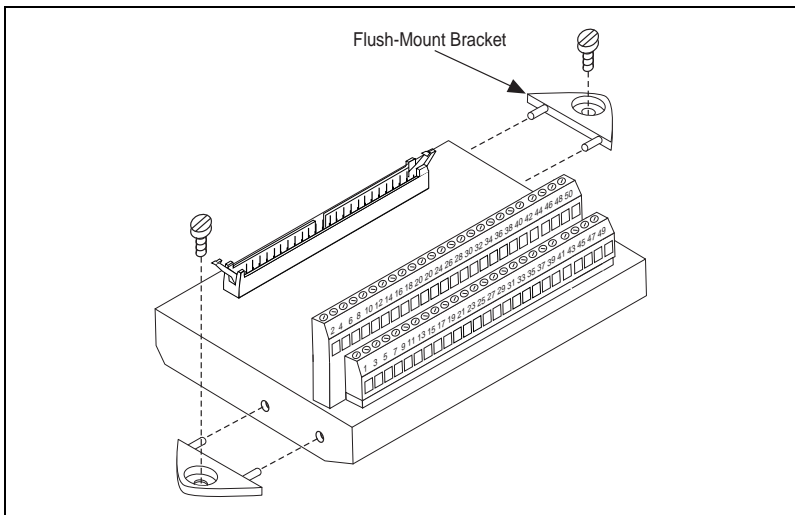

Figure 4. Inserting the Flush-Mount Brackets

Place the connector block where you want to mount it and screw it into place.

- For rail mounting, pry off the right and left ends of the connector block with a screwdriver as shown in Figure 5.

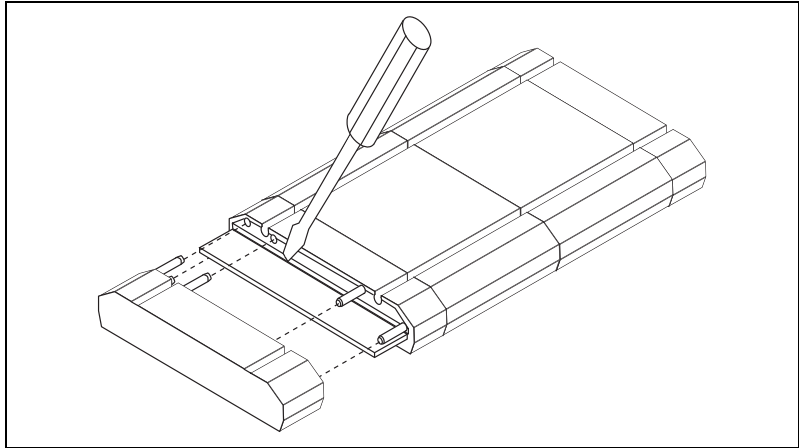

Figure 5. Removing the Connector Block Ends

Insert the rail-mount bracket into the slots on the bottom of the connector block as shown in Figure 6.

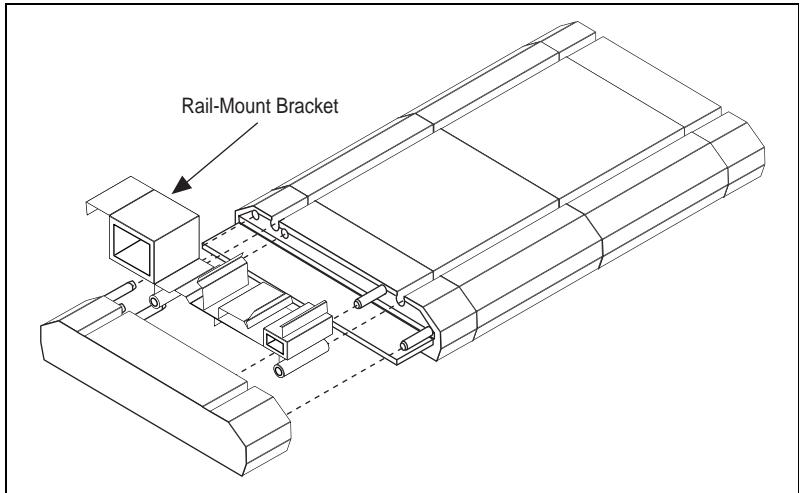

Figure 6. Inserting the Rail-Mount Bracket

Replace the end of the connector block and push very firmly until it snaps into place. Repeat for the other side, making sure that both rail-mount brackets are facing the same direction.

Slide the rail-mount brackets of the connector block onto your rails.

5. Repeat the mounting procedure in step 4 for the second connector block.
6. Plug one of the 50-pin connectors on the free end of a ribbon cable into one of the connector blocks. Align the tabs and arrows as shown in Figure 7.

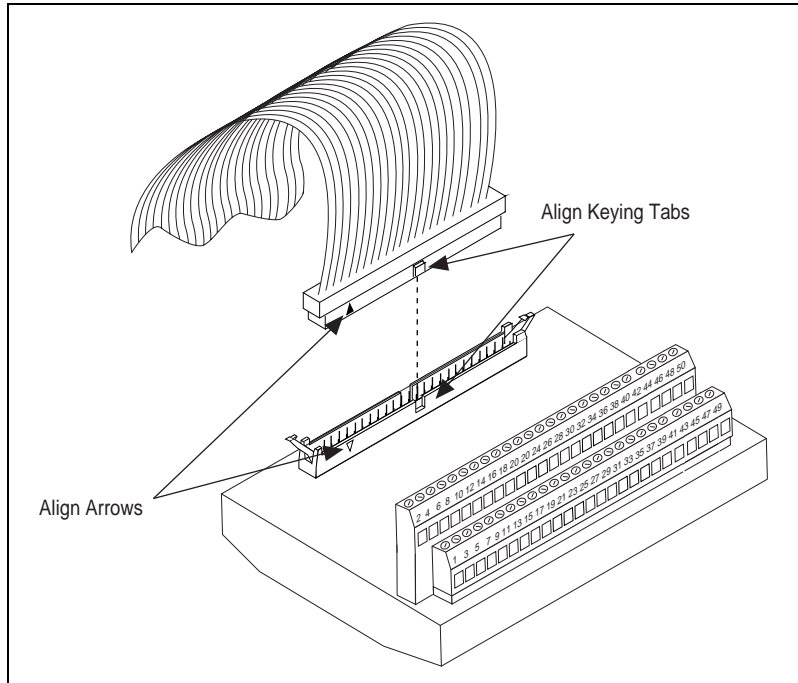

Figure 7. Connecting the Cable to the Connector Block

7. Firmly push in the connector until the ejector ears on the block header connector snap into position.
8. Repeat steps 6 and 7 for the remaining 50-pin connector on the free end of the cable and the remaining connector block.

Notice that signals are labeled 1 through 50 on both of the connector blocks. For the cable labeled *positions 1-50*, the connector block numbers correspond to the rear panel I/O connector pin numbers on the board. The numbers appearing on the connector block for the second cable, which is labeled *positions 51-100*, are offset by 50.

Removal

1. Press down on the ejector ears of the connector block. The connector will pop out.
2. At the other end, grasp the ribbon cable near the connector end and gently pull it away from the board with a rocking motion.