

---

# SCB-19 Safety, Environmental, and Regulatory Information

---

2022-07-06



# Contents

SCB-19 Purpose and Introduction..... 3

# SCB-19 Purpose and Introduction

This document explains how to connect and use the SCB-19 with AUX I/O connectors on National Instruments hardware.

Figure 1. SCB-19 Connector Block

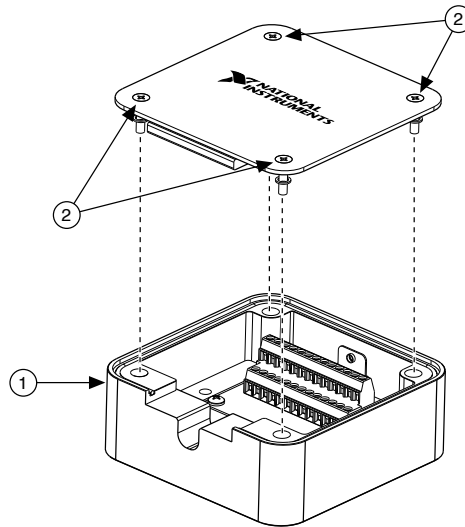

1. SCB-19
2. Cover screws

## Other Equipment

There are several required items not included in your SCB-19 kit that you need to operate the SCB-19.

## Required Items

- NI hardware with compatible 19-pin AUX I/O connector
- Cable assembly
  - For NI hardware with standard HDMI connectors: SHH19-H19-AUX shielded single-ended cable (NI part number 152629-0x)
  - For NI hardware with mini HDMI connectors: SHH19-MH19-AUX shielded single-ended cable (NI part number 784091-01)



**Note** The specified performance of the AUX I/O connector is not guaranteed if a third-party HDMI cable is used. Use one of the recommended cables for all AUX I/O connections.

- Phillips #1 screwdriver
- 0.125 in. flathead screwdriver
- Shielded, multiconductor cable with 14–30 AWG wire
- Wire cutters
- Wire insulation stripper

Visit [ni.com](http://ni.com) for more information about these additional items.

## Screw Terminal Diagram

Refer to the following figure for information about the interior of the SCB-19 when connecting the SCB-19.

Figure 2. Interior of the SCB-19

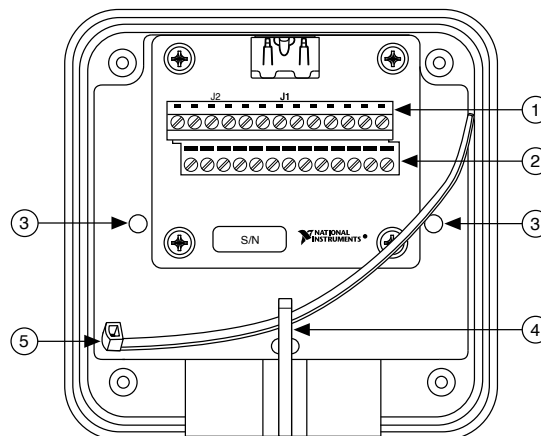

1. I/O screw terminals
2. Ground terminals
3. Wall mounting screw holes
4. Cable tie loops
5. Cable tie

## Getting Started with the SCB-19

Complete the following steps to connect and use the SCB-19 with NI hardware:

Install your NI hardware in a chassis. Refer to the hardware documentation for your product(s) for installation instructions.

1. Remove the four cover screws with a Phillips #1 screwdriver and open the top cover, as shown in [Figure 1](#).
2. Connect wires to the screw terminals.



**Caution** To ensure the EMC performance specified for the connected hardware, any wires connected to screw terminals that exit the enclosure must be shielded. NI recommends using a multiconductor cable with an overall shield. Terminate the cable shield to one of the PCB mounting screws.

1. Strip 6.35 mm (0.25 in.) of insulation from the wires.
2. Insert the wires into the screw terminals.
3. Securely tighten the screws with the flathead screwdriver to a torque of 0.5 N · m to 0.6 N · m (4.43 lb · in. to 5.31 lb · in.).



**Tip** You can neaten the wires and provide mechanical support by sliding a cable tie through one of the slots shown in [Figure 2](#), wrapping the cable tie around the wires, and tightening the cable tie.

3. Close the top cover and tighten the four cover screws.



4. **Caution** Refer to the documentation for the hardware you connect the SCB-19 to for maximum voltage specifications. Using voltages outside of the specified range could damage the SCB-19 and any instruments connected to it. NI is not liable for any damage resulting from using voltages outside of the recommended range.

Connect the SCB-19 to the AUX I/O connector on your NI hardware using an SHH19-H19-AUX or SHH19-MH19-AUX cable and tighten the target screw, as shown in the following figure.

Figure 3. SCB-19 Cable Connection

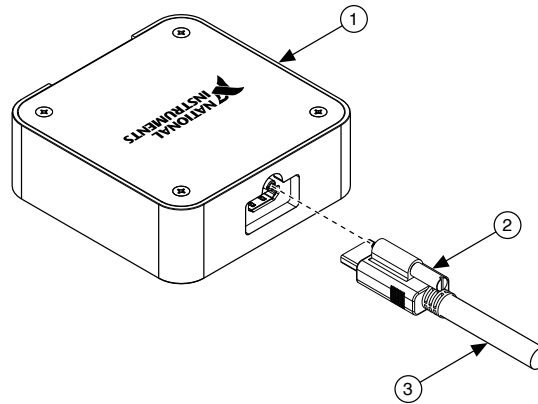

1. SCB-19
2. Target screw
3. Cable assembly

When you have finished using the SCB-19, power off any external signals connected to the SCB-19 before you power off your computer.



**Caution** Clean the hardware with a soft, nonmetallic brush. Make sure that the hardware is completely dry and free from contaminants before returning it to service.

## Mounting Holes

You can mount the SCB-19, either vertically or horizontally, on a DIN rail in an industrial environment.

You can purchase a compatible DIN rail kit from NI using the part number 781740-01.

The SCB-19 also has two screw holes for a generic wall mount. These wall mount holes are designed for use with a #4 or #6 panhead screw with a minimum length of 15.88 mm (0.625 in.).

Figure 4. SCB-19 Mounting Screw Holes

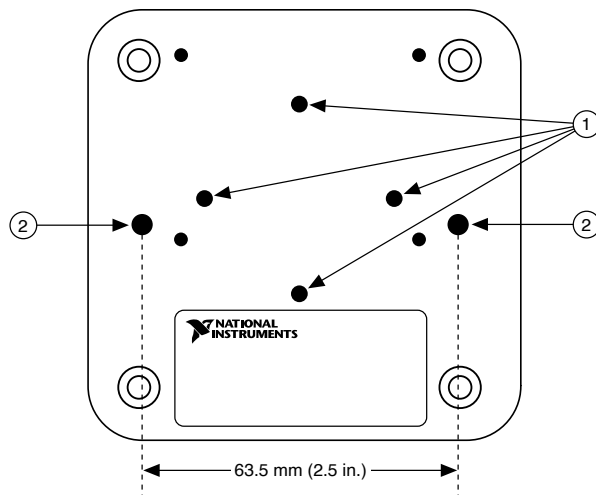

1. DIN rail mounting screw holes
2. Wall mounting screw holes

### Physical Characteristics

Dimensions	8.7 cm × 8.7 cm × 3.1 cm (3.4 in. × 3.4 in. × 1.2 in.)
Weight	355 g (12.5 oz)
Connector type	H19  Screw terminals

### Environment

Maximum altitude	2,000 m (800 mbar) (at 25 °C ambient temperature)
------------------	---

Pollution Degree	2
------------------	---

Indoor use only.

## Operating Environment

Ambient temperature range	0 °C to 55 °C (Tested in accordance with IEC 60068-2-1 and IEC 60068-2-2. Meets MIL-PRF-28800F Class 3 low temperature limit and MIL-PRF-28800F Class 2 high temperature limit.)
Relative humidity range	10% to 90%, noncondensing (Tested in accordance with IEC 60068-2-56.)

## Storage Environment

Ambient temperature range	-20 °C to 70 °C (Tested in accordance with IEC 60068-2-1 and IEC 60068-2-2. Meets MIL-PRF-28800F Class 3 limits.)
Relative humidity range	5% to 95%, noncondensing (Tested in accordance with IEC 60068-2-56.)

## Shock and Vibration

Operating shock	30 g peak, half-sine, 11 ms pulse (Tested in accordance with IEC 60068-2-27. Meets MIL-PRF-28800F Class 2 limits.)
<p><b>Random vibration</b></p> <p>Operating 5 Hz to 500 Hz, 0.3 g<sub>rms</sub> (Tested in accordance with IEC 60068-2-64.)</p> <p>Nonoperating 5 Hz to 500 Hz, 2.4 g<sub>rms</sub> (Tested in accordance with IEC 60068-2-64. Test profile exceeds the requirements of MIL-PRF-28800F, Class 3.)</p>	



## Compliance and Certifications

### Safety

This product is designed to meet the requirements of the following electrical equipment safety standards for measurement, control, and laboratory use:

- IEC 61010-1, EN 61010-1
- UL 61010-1, CSA C22.2 No. 61010-1



**Note** For UL and other safety certifications, refer to the product label or the [Online Product Certification](#) section.

### CE Compliance

This product meets the essential requirements of applicable European Directives, as follows:

- 2006/95/EC; Low-Voltage Directive (safety)
- 2004/108/EC; Electromagnetic Compatibility Directive (EMC)

### Online Product Certification

Refer to the product Declaration of Conformity (DoC) for additional regulatory compliance information. To obtain product certifications and the DoC for this product, visit [ni.com/certification](https://ni.com/certification), search by model number or product line, and click the appropriate link in the Certification column.

### Environmental Management

NI is committed to designing and manufacturing products in an environmentally responsible manner. NI recognizes that eliminating certain hazardous substances from our products is beneficial to the environment and to NI customers.

For additional environmental information, refer to the **Minimize Our Environmental Impact** web page at [ni.com/environment](https://ni.com/environment). This page contains the

environmental regulations and directives with which NI complies, as well as other environmental information not included in this document.

## Waste Electrical and Electronic Equipment (WEEE)

**EU Customers** At the end of the product life cycle, all NI products must be disposed of according to local laws and regulations. For more information about how to recycle NI products in your region, visit [ni.com/environment/weee](https://ni.com/environment/weee).

## 电子信息产品污染控制管理办法 ( 中国 RoHS )

**中国客户** National Instruments 符合中国电子信息产品中限制使用某些有害物质指令(RoHS)。关于 National Instruments 中国 RoHS 合规性信息，请登录 [ni.com/environment/rohs\\_china](https://ni.com/environment/rohs_china)。(For information about China RoHS compliance, go to [ni.com/environment/rohs\\_china](https://ni.com/environment/rohs_china).)

## Worldwide Support and Services

The NI website is your complete resource for technical support. At [ni.com/support](https://ni.com/support), you have access to everything from troubleshooting and application development self-help resources to email and phone assistance from NI Application Engineers.

Visit [ni.com/services](https://ni.com/services) for NI Factory Installation Services, repairs, extended warranty, and other services.

Visit [ni.com/register](https://ni.com/register) to register your NI product. Product registration facilitates technical support and ensures that you receive important information updates from NI.

A Declaration of Conformity (DoC) is our claim of compliance with the Council of the European Communities using the manufacturer's declaration of conformity. This system affords the user protection for electromagnetic compatibility (EMC) and product safety. You can obtain the DoC for your product by visiting [ni.com/](https://ni.com/)

certification. If your product supports calibration, you can obtain the calibration certificate for your product at [ni.com/calibration](https://ni.com/calibration).

NI corporate headquarters is located at 11500 North Mopac Expressway, Austin, Texas, 78759-3504. NI also has offices located around the world. For telephone support in the United States, create your service request at [ni.com/support](https://ni.com/support) or dial 1 866 ASK MYNI (275 6964). For telephone support outside the United States, visit the **Worldwide Offices** section of [ni.com/niglobal](https://ni.com/niglobal) to access the branch office websites, which provide up-to-date contact information, support phone numbers, email addresses, and current events.