NI-9326

Specifications

2022-07-11



Contents

NI-9326 Datasheet.....	3
NI-9326 Specifications.....	23

NI-9326 Datasheet

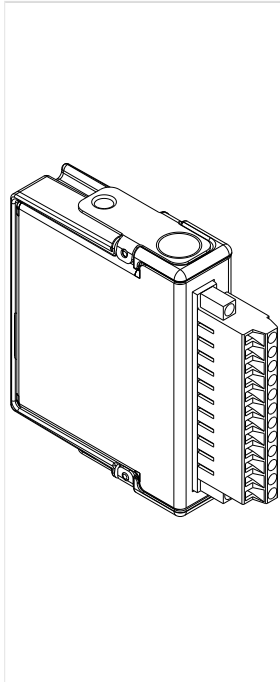



- Screw terminal connectivity
- 150 V RMS, CAT I, channel-to-channel and channel-to-earth isolation
- 0.025 Hz to 128 kHz frequency input range
- Configurable lowpass filters
- Support for Variable Reluctance (VR) and Hall-Effect sensors
- -40 °C to 70 °C operating, 5 g vibration, 50 g shock

The NI-9326 frequency input module features 6 channel-to-channel isolated differential input channels that route to 6 embedded counters capable of frequency, period, and edge counting measurements. The inputs are designed for connection to variable reluctance sensors, single channel encoders, and hall-effect sensors. The differential input can measure both single-ended and differential signals.

You can synchronize the module measurements with other analog, digital, and counter measurements in your system. The NI-9326 counter logic is embedded within the module and does not use up any backplane counter resources.

For frequency and period measurements, the NI-9326 counters provide a configurable Butterworth lowpass filter to easily filter out noise in the system.

	Kit Contents	<ul style="list-style-type: none"> • NI 9326 • NI 9326 Getting Started Guide
	Accessories	<ul style="list-style-type: none"> • NI 9929 Backshell Connector Kit (Screw Terminal)

NI C Series Overview



NI provides more than 100 C Series modules for measurement, control, and communication applications. C Series modules can connect to any sensor or bus and allow for high-accuracy measurements that meet the demands of advanced data acquisition and control applications.

- Measurement-specific signal conditioning that connects to an array of sensors and signals
- Isolation options such as bank-to-bank, channel-to-channel, and channel-to-earth ground
- -40 °C to 70 °C temperature range to meet a variety of application and environmental needs
- Hot-swappable

The majority of C Series modules are supported in both CompactRIO and CompactDAQ platforms and you can move modules from one platform to the other with no modification.

CompactRIO



CompactRIO combines an open-embedded architecture with small size, extreme ruggedness, and C Series modules in a platform powered by the NI LabVIEW reconfigurable I/O (RIO) architecture. Each system contains an FPGA for custom timing, triggering, and processing with a wide array of available modular I/O to meet any embedded application requirement.

CompactDAQ

CompactDAQ is a portable, rugged data acquisition platform that integrates connectivity, data acquisition, and signal conditioning into modular I/O for directly interfacing to any sensor or signal. Using CompactDAQ with LabVIEW, you can easily customize how you acquire, analyze, visualize, and manage your measurement data.



Software

LabVIEW Professional Development System for Windows

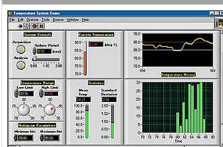

- Use advanced software tools for large project development
- Generate code automatically using DAQ Assistant and Instrument I/O Assistant
- Use advanced measurement analysis and digital signal processing
- Take advantage of open connectivity with DLLs, ActiveX, and .NET objects
- Build DLLs, executables, and MSI installers

NI LabVIEW FPGA Module

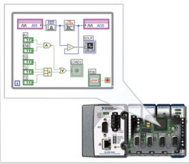

- Design FPGA applications for NI RIO hardware
- Program with the same graphical environment used for desktop and real-time applications
- Execute control algorithms with loop rates up to 300 MHz
- Implement custom timing and triggering logic, digital protocols, and DSP algorithms
- Incorporate existing HDL code and third-party IP including Xilinx IP generator functions
- Purchase as part of the LabVIEW Embedded Control and Monitoring Suite

NI LabVIEW Real-Time Module

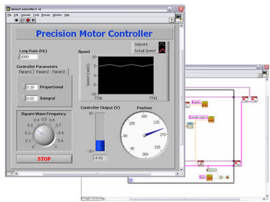

- Design deterministic real-time applications with LabVIEW graphical programming
- Download to dedicated NI or third-party hardware for reliable execution and a wide selection of I/O
- Take advantage of built-in PID control, signal processing, and analysis functions
- Automatically take advantage of multicore CPUs or set processor affinity manually
- Take advantage of real-time OS, development and debugging support, and board support
- Purchase individually or as part of a LabVIEW suite

Input Circuitry

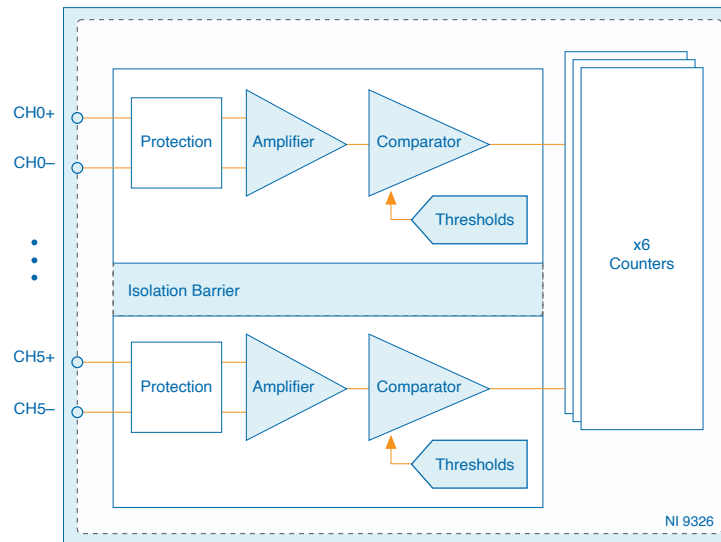

- Input signals on each channel are filtered and passed through a comparator with configurable threshold and hysteresis.
- Each input channel provides an independent configuration to enable independent data sampling by the counter.
- The module protects each channel from overvoltages.

NI-9326 Front End Control

The NI-9326 has 6 input channels which have independent settings as follows:

- Configurable input signal rising or falling edge detection
- Configurable threshold and hysteresis
- Configurable digital glitch filter

I/O Protection

The voltage input level and the current input level of the digital signals are listed in the specifications of your device. The I/O protection circuitry protects the module in events such as overvoltage, overcurrent, and ESD. Refer to the [Input Characteristics](#) section for more information about the protection level supported.

Configurable Threshold and Hysteresis

The NI-9326 provides a configurable threshold and hysteresis on each of the input channels. The use of the hysteresis helps eliminate incorrect triggering caused by a noisy input signal around the threshold level. Input edges are detected when the input signal crosses the threshold in the direction selected. Hysteresis is applied either above or below the threshold depending on the selected direction. The diagrams below illustrates how the direction, threshold, and hysteresis work together to determine the resulting hardware trigger levels.

Figure 1. Input Signal Edge Detection: Rising

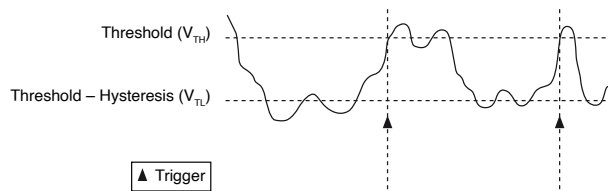
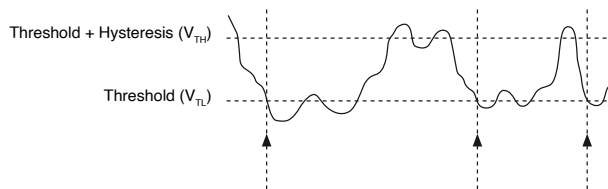

Figure 2. Input Signal Edge Detection: Falling



The upper and lower thresholds achieved from the mathematical operation between the configured threshold and hysteresis values are ultimately still limited by the threshold range supported by the NI-9326. Refer to the [Input Characteristics](#) section for more information about the threshold range supported. The following are examples of threshold and hysteresis values with final trigger levels:

- Exceeding upper threshold range
 - Input signal edge detection: Falling
 - Threshold: 8 V
 - Hysteresis: 5 V
 - Final trigger levels:

- Threshold + Hysteresis: 9.5 V (limited by the threshold range supported)
- Threshold: 8 V
- Exceeding lower threshold range
 - Input signal edge detection: Rising
 - Threshold: -8 V
 - Hysteresis: 5 V
 - Final trigger levels:
 - Threshold: -8 V
 - Threshold - Hysteresis: -9.5 V (limited by the threshold range supported)

To get a valid measurement, configure the edge detection and threshold for a point that occurs only once during the signal period. Then configure a hysteresis value large enough to filter out noise around the threshold while still detecting valid transitions. Hysteresis should always be set greater than 0 V.

For example, a VR sensor connected with the proper polarity will idle around 0 V. The sensor output will go positive as a ferrous material approaches the sensor and then swings rapidly back through zero as it moves past the center of the sensor. To get the best measurement, configure the falling edge detection with a 0 V threshold to trigger on this fast falling edge. Configure enough hysteresis to filter out noise that occurs around 0 V while still detecting valid pulses. The following diagram shows an example waveform and configuration for a VR sensor.

- Input signal edge detection: Falling
- Threshold: 0 V
- Hysteresis: 31.25 mV

Figure 3. VR Sensor Waveform

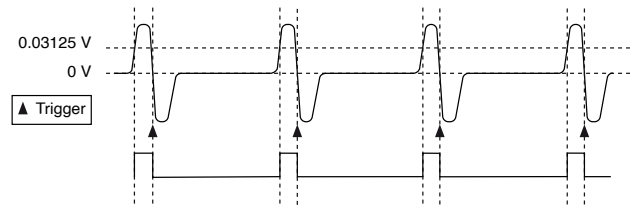

The following diagram shows the waveform output from a 5 V CMOS digital IC. This waveform has fast rising and falling edges, so either edge works well for counting. This example shows counting rising edges with the threshold placed in the middle of the signal swing:

- Input signal edge detection: Rising
- Threshold: 2.5 V
- Hysteresis: 0.5 V

Figure 4. 5 V CMOS Digital IC Waveform

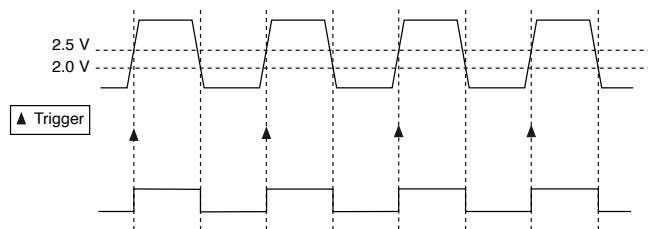

Programmable Digital Glitch Filter

The NI-9326 has a digital glitch filter on each of the input lines that are essentially timers to filter unwanted glitches, transitions, or noise on the input signal.

You can configure the following filter properties for each of the input lines:

- Enable or disable the digital glitch filter.
- Minimum pulse width of the input signal that passes through the filter.

The filter time is the minimum pulse width value set by the user. The timer begins at both the rising and falling edge of the unfiltered input signal and the previous value of the input signal is read for the duration of the filter time. After the filter time

elapses and no new edges on the input signal have occurred, the new input signal value is read. The filter timer restarts at the next edge of the unfiltered input signal.

Figure 5. Low to High Input Signal Transition

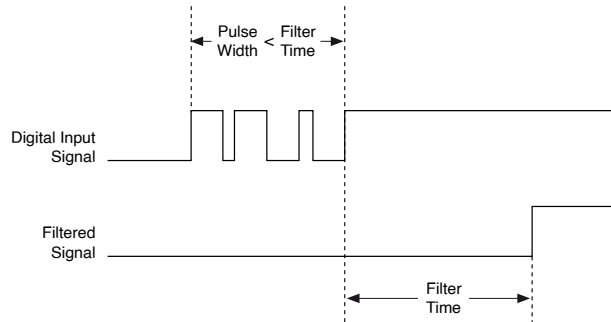
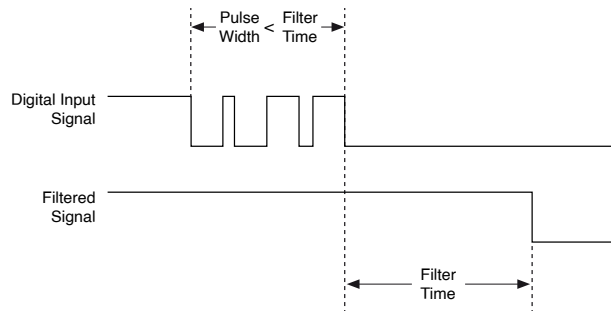

Figure 6. High to Low Input Signal Transition



The input signal will have distortion due to the limited bandwidth of the module. The following formula is used to determine the accurate minimum pulse width to be configured for the digital glitch filter of the module, based on the maximum pulse width desired to be filtered and other required parameters:

$$\text{Glitch Pulse Width Input} = \text{User Desired Glitch Pulse Width} + 0.66 \mu\text{s} \times \ln \left(\frac{V_{IH} - V_{TH}}{V_{TL} - V_{IL}} \right) - 63 \text{ ns}$$

where

- V_{IH} is input HIGH level of signal
- V_{IL} is input LOW level of signal
- V_{TH} is the upper threshold level
- V_{TL} is the lower threshold level
- $V_{TL} > V_{IL}$
- $V_{TH} < V_{IH}$

- $V_{IH} - V_{IL} < 25 V_{pp}$
- V_{TH} and V_{TL} must be within 10% to 90% of the square wave amplitude



Note Both V_{TH} and V_{TL} can be determined based on the input signal transition diagrams shown in [Figure 1](#) and [Figure 2](#).

Counter Input Measurements

Frequency/Period Measurement

You can take frequency or period measurements with the NI-9326. The counter measures and returns the period information of a signal. The NI-9326 returns the current period measurement values when the counter is read. The raw counter period measurements consist of two different values:

- A — The period measured in ticks of the 100 MHz counter timebase
- B — Scaling factor for the period measured

You can calculate the measured period using the following equation:

$$\text{Measured Period} = \frac{\text{Number of Ticks} \times \text{Timebase}}{\text{Scaling Factor}} = \frac{A \times 10 \text{ ns}}{B}$$

where

- Number of Ticks (A) and Scaling Factor (B) are the raw values returned by the counter
- 10 ns is the 100 MHz counter timebase period

Example measurement of a 1 kHz input signal:

- A = 3,200,000
- B = 32
- Measured period = $(3,200,000 \times 10 \text{ ns})/32 = 1 \text{ ms}$

You can calculate the frequency using the following equation:

$$\text{Signal Frequency} = \frac{1}{\text{Signal Period}}$$

Channel Settings

You can configure the following counter properties:

- Input terminal of the signal-to-measure.
- The active edge, rising or falling, that is counted^[1].
- Butterworth filter enabling/disabling
- Butterworth cutoff frequency

Measurement Method

Filter Enabled

You can configure the following properties of the frequency/period measurement method when using the Butterworth filter:

- Enable Butterworth filter
 - Enable Butterworth filter determines whether every single period measurement of the input signal passes through the digital low pass filter or not. Enabling this feature helps in filtering out the variations in the period measured.
- Filter Frequency
 - Filter Frequency specifies the cut-off frequency of the 2nd order Butterworth filter when enabled. The 2nd order Butterworth filter provides thirteen selectable cut-off frequencies that are configurable per channel if enabled. Refer to [Table 1](#) for more information.

The Butterworth filter reduces the variations in the measured frequency caused by noise in the system. In the following example, a measurement of a desired 100 kHz signal with an unwanted noise source of 1 kHz superimposed on top of the signal causes the signal measurement to vary between 99 kHz and 101 kHz if filter is not enabled.

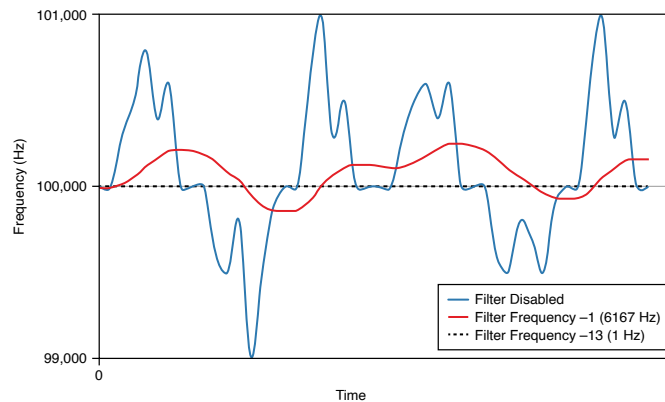

Enabling the Butterworth filter does not attenuate the fundamental 100 kHz test frequency itself but reduces the spread of the frequency due to the noise. Therefore, the desired 100 kHz signal can still be measured even with the lowest 1 Hz cutoff.

The Butterworth filter is configured by selecting the desired filter cut-off frequency. The following figure shows the response in the frequency domain for each of the available filter frequencies:

Figure 7. Butterworth Low Pass Filter Response

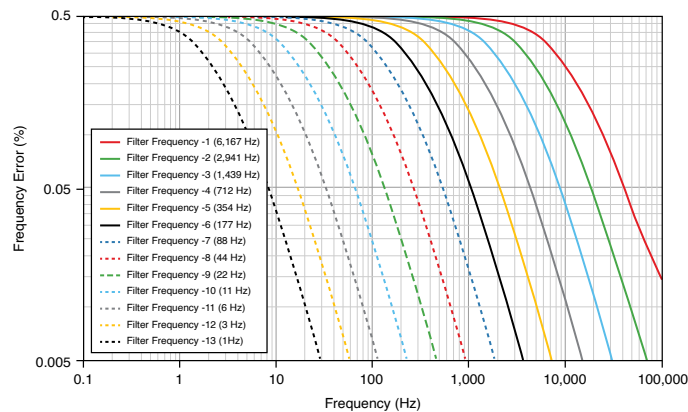

Selecting a lower filter frequency provides more filtering of the input noise, but it will add longer filter delay and filter settling time. The filter delay represents the processing time added by the filter. The filter settling time shows the time required to reach 99% of the input step. Refer to [Table 1](#) for the filter delay and settling time.

Any step response change of the test frequency will take longer to settle for filters with a lower cut-off frequency as shown in the following figure, where the frequency measurement changes from 10 kHz to 50 kHz at T1:

Figure 8. Butterworth Low Pass Filter Settling Time

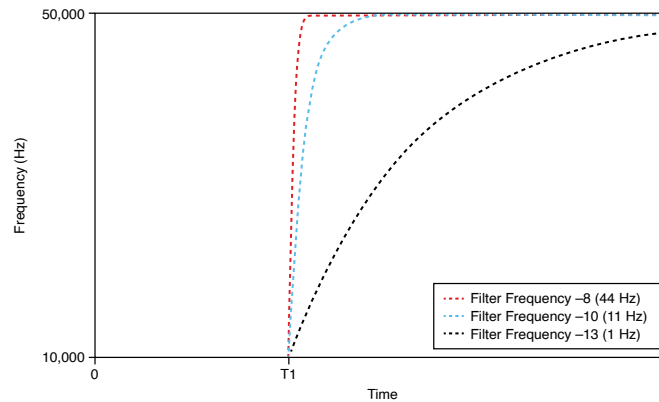

Filter Disabled

You can configure the following properties of the frequency/period measurement method when not using the Butterworth filter:

- Divisor
 - Divisor specifies the number of periods of the input signal to measure to determine the average input signal period.
- Measurement Time
 - Measurement Time specifies the amount of time over which to measure and average multiple periods of the input signal. In this measurement mode, the counter measures how ever many periods of the input signal fit within the specified Measurement Time.
- Maximum Measurable Period
 - You can set the maximum measurable period of the signal. If the input signal period is slower than this value, the counter returns a measurement value of zero. Use this property to get updated measurement data when the signal slows down or is stopped instead of previous measurements. To disable this feature, set the maximum measurable period to zero. When this

feature is disabled, the counter keeps measuring until a valid measurement is detected, the counter overflows, or the user stops the counter.



Note The measurement time, divisor, and maximum measurable period parameters are ignored when the Butterworth filter is enabled.

When both the Divisor and the Measurement Time values are set, the counter goes into Dynamic Averaging mode. In this mode, the counter simultaneously performs the measurement based on both the Divisor and Measurement Time settings, and returns whichever measurement completes first. The following table shows the summary of the different setting combinations.

Divisor	Measurement Time	Counter Characteristic
1	0 (Disabled)	Measure 1 period of the input signal.
N	0 (Disabled)	Measure N periods of the input signal.
0 (Disabled)	M	Measures all the period of the input signals that occur within the M measurement time.
N	M	Returns the measurement of N periods of the input signal or the measurement that occurs within the M measurement time, whichever completes first.

The measurement time and divisor settings affect the measurement error and latency. Increasing the divisor or measurement time improves the measurement accuracy but also reduces the measurement rate.

The following figure shows an example of setting the Divisor to 1 for the frequency measurement.

Figure 9. Measurement with Divisor set to 1

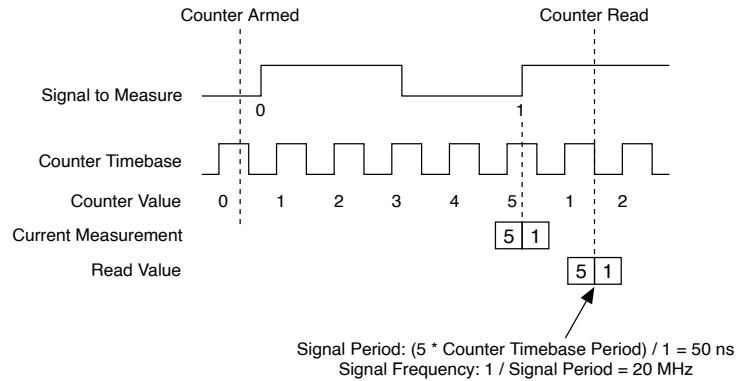

The following figure shows an example of setting the Divisor to 3 for the frequency measurement.

Figure 10. Measurement with Divisor set to 3

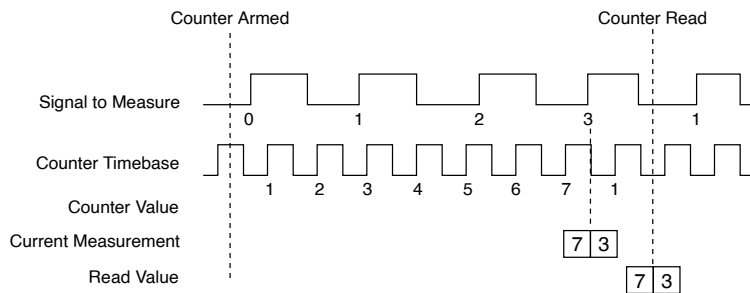

The following figure shows an example of Measurement Time.

Figure 11. Measurement using Measurement Time

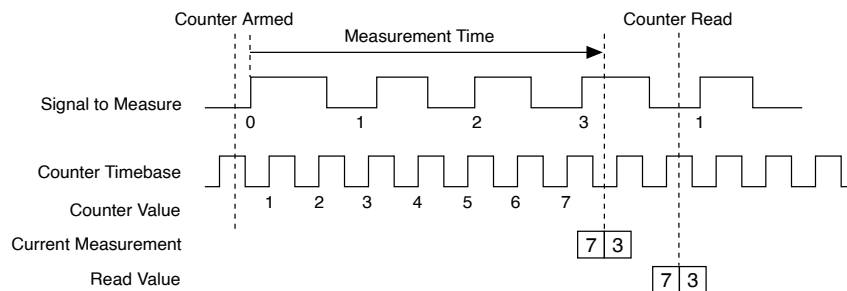

In the following examples, both the Divisor and Measurement Time are set for frequency measurement.

In the following figure, the Divisor period of the input signal, in this case 3, is met before the measurement time elapsed, thus the Divisor setting is used for the frequency measurement.

Figure 12. Divisor completes before Measurement Time

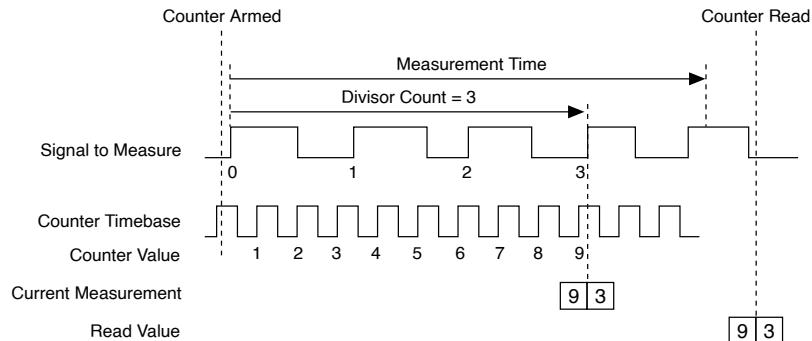

In the following figure, the measurement time elapsed before the 3 divisor periods of the input signal, thus the Measurement Time setting is used for the frequency measurement.

Figure 13. Measurement Time completes before Divisor

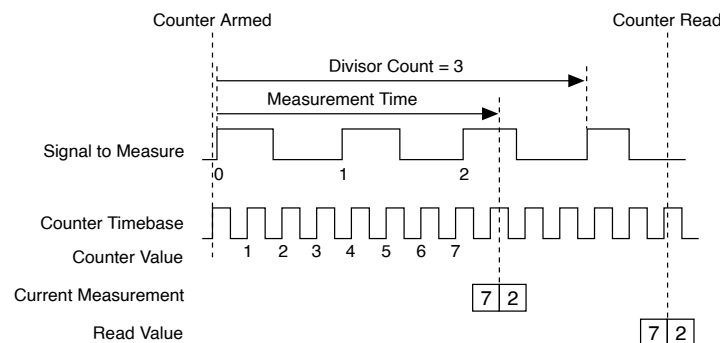

Trigger Settings

Counter Arm—You can control when the counter starts the frequency measurement through the counter arm control. After the counter is armed, it waits for the active edge on the signal-to-measure, and then it begins measuring the signal period. The measurement data is only ready and valid once the counter has finished measuring the first measurement according to the Divisor and Measurement Time settings. The counter returns a value of zero for both the Number of Ticks (A) and Scaling

Factor (B) prior to the first measurement becoming ready. Refer to your software documentation for more information on arming the counter.

Edge Counting

You can take edge counting measurements with the NI-9326. The counter counts the number of active edges on a signal. The NI-9326 returns the current count value when the counter is read. The following figure shows an example of edge counting.

Figure 14. Edge Counting

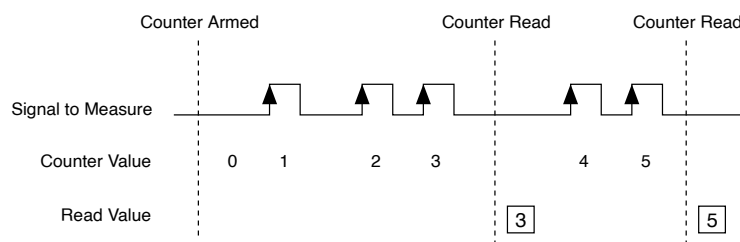

Channel Settings

You can configure the following counter properties:

- Input terminal of the signal-to-measure.
- The initial value of the count.
- The active edge, rising or falling, that is counted^[2].
- Count direction to increment or decrement the counter on each edge. You can set this property to:
 - Count Up
 - Count Down
 - Externally Controlled



Note If you select Externally Controlled, the NI-9326 monitors a hardware signal to determine the count direction. When the signal is high, the counter counts up; when the signal is low, the counter counts down. You can set which signal to monitor.

- Counter Reset
 - You can configure the counter to reset the count to a specific value in response to a hardware signal using the following Reset Trigger properties:
 - Enable or disable the Reset Trigger feature.
 - Input terminal of the signal to be used as the Reset Trigger.
 - The reset value to change the count value to in response to the Reset Trigger.
- Count Edges Pause Trigger
 - You can configure the counter to pause counting based on a hardware signal using the following properties:
 - Enable or disable the Count Edges Pause Trigger feature.
 - Input terminal of the signal to be used as the Count Edges Pause Trigger.

The following figure shows an example of a count edge measurement using the Reset Trigger with the initial value of the count value set to 6, Reset Trigger active edge set to rising edge, and the reset value set to 3.

Figure 15. Reset Trigger

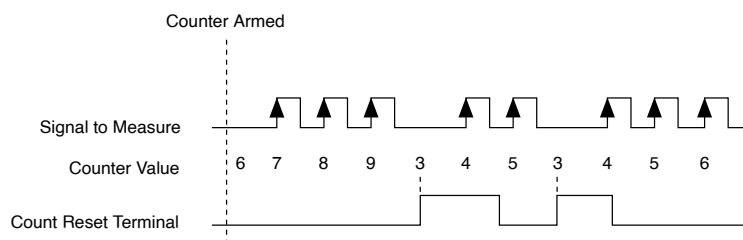

The following figure shows an example of edge counting with Count Edges Pause Trigger level set to high.

Figure 16. Count Edges Pause Trigger

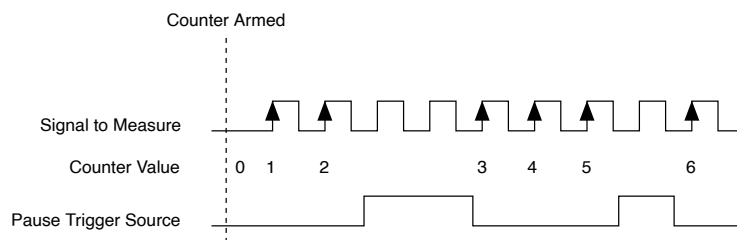

Trigger Settings

Counter Arm—You can control when the counter starts counting through the counter arm control. The counter waits for the active edge on the signal-to-measure after it is armed, and counts on every active edge on the signal-to-measure. Refer to your software documentation for more information on arming the counter.

NI-9326 Parallel DI Measurements

The NI-9326 supports a passthrough DI mode only for CompactRIO systems.

In this measurement mode, the input signal bypasses the counter and its digital input value can be read directly. The counter measurements will not be available when using this passthrough mode. To enable the DI measurement mode, select the module DI mode using the Module Properties page in the LabVIEW project. Refer to the detected signal diagram in the [Configurable Threshold and Hysteresis](#) section for an example of the DI waveform that can be read in this mode.

Channel Settings

You can only configure the following DI properties as a subset of the available settings for the input channel:

- Threshold and hysteresis of the input channel.
- Input signal rising or falling edge detection.



Note The digital glitch filter is not supported in this measurement mode.

NI-9326 Counter Signal Routing

The NI-9326 has flexible signal routing features. The input signals to the counters can be routed from any of the six input channels. You can change the signal routing by configuring the counter properties.

The software routes certain input signals to each of the counters by default. The following table shows the default routing for counter signals.

Measurement	Signal	Counter					
		0	1	2	3	4	5
Period/Frequency	Source	DI0	DI1	DI2	DI3	DI4	DI5
Edge Counting	Source	DI0	DI1	DI2	DI3	DI4	DI5
	Reset	DI3	DI4	DI5	DI0	DI1	DI2
	Count Direction	DI5	DI2	DI4	DI1	DI3	DI0
	Pause Trigger	DI4	DI5	DI1	DI2	DI0	DI3

Table 1. Default Routing for Counter Signals

¹ The active edge that is counted refers to the input signal rising or falling detection that is selected for the input terminal to the counter.

² The active edge that is counted refers to the input signal rising or falling detection that is selected for the input terminal to the counter.

NI-9326 Specifications

The following specifications are typical for the range -40 °C to 70 °C unless otherwise noted.



Caution Do not operate the NI-9326 in a manner not specified in this document. Product misuse can result in a hazard. You can compromise the safety protection built into the product if the product is damaged in any way. If the product is damaged, return it to NI for repair.

Input Characteristics

Number of inputs	6
Input type	Differential or single-ended
Input range	150 V RMS maximum; ± 50 mV minimum
I/O protection	
Input voltage (CH+ to-CH-)	150 V RMS
Input bandwidth (-3 dB)	241 kHz
Input frequency range	0.025 Hz — 128 kHz
Input pulse width detection ^[1]	2.0 μ s minimum
Configurable input active edge per channel	Rising/Falling edge detection
Configurable input threshold range per channel	-9.5 V to 9.5 V

Configurable input hysteresis range per channel	0 V to 5 V
Input threshold error	0.6% maximum
Input threshold resolution	7.8 mV
Digital Glitch Filter line filtering settings, programmable per line	0 ns (disabled) to 5.24 ms in 80 ns steps
Input propagation delay ^[1]	1.67 μ s maximum
Input channel-to-channel skew ^[1]	85 ns maximum
Input pulse width distortion ^[1]	1.53 μ s maximum

Butterworth filter

Filter order 2nd order

Filter Frequency	Cut-off Frequency	Filter Delay	Filter Settling ^[2]
Filter Frequency - 1	6167 Hz	0.037 ms	0.120 ms
Filter Frequency - 2	2941 Hz	0.070 ms	0.250 ms
Filter Frequency - 3	1439 Hz	0.137 ms	0.513 ms
Filter Frequency - 4	712 Hz	0.270 ms	1.032 ms
Filter Frequency - 5	354 Hz	0.537 ms	2.075 ms
Filter Frequency - 6	177 Hz	1.069 ms	4.163 ms
Filter Frequency - 7	88 Hz	2.135 ms	8.332 ms
Filter Frequency - 8	44 Hz	4.266 ms	16.673 ms
Filter Frequency - 9	22 Hz	8.529 ms	33.360 ms
Filter Frequency - 10	11 Hz	17.054 ms	66.727 ms
Filter Frequency - 11	6 Hz	34.103 ms	133.463 ms
Filter Frequency - 12	3 Hz	68.202 ms	266.940 ms

Filter Frequency	Cut-off Frequency	Filter Delay	Filter Settling ^[2]
Filter Frequency - 13	1 Hz	136.401 ms	533.886 ms

Table 2. Butterworth Filter Cut-off Frequencies and Filter Delays

Counter Features

Number of counters	6 counters
Resolution	32 bits
Sample rate	102.4 kHz maximum
Counter measurements	Frequency, Period, Edge counting
Internal timebase	100 MHz
Timebase accuracy	±64 ppm maximum
Input routing	Any channel can drive any counter input

Power Up Default Input and Counter Configuration

Threshold level	0 V
Hysteresis level	31.25 mV
Input Active Edge Detection	Rising
Digital Glitch Filter pulse width	0.48 μ s
Butterworth Filter	Enabled

Butterworth Low Pass Filter cut-off	Filter Frequency-1
-------------------------------------	--------------------

Frequency Measurement Accuracy

Filter Mode	Maximum Accuracy (%)	Typical Noise (Hz Peak)
Filter Disabled (Divisor=1)	0.2568	1660
Filter Frequency — 1	0.0424	825
Filter Frequency — 2	0.0245	410
Filter Frequency — 3	0.0174	164
Filter Frequency — 4	0.0124	66
Filter Frequency — 5	0.0111	25
Filter Frequency — 6	0.0088	12
Filter Frequency — 7	0.0084	6
Filter Frequency — 8	0.0084	6
Filter Frequency — 9	0.0084	6
Filter Frequency — 10	0.0084	6
Filter Frequency — 11	0.0084	6
Filter Frequency — 12	0.0084	6
Filter Frequency — 13	0.0084	6

Table 3. Frequency Accuracy (for 128 kHz input)

Figure 17. Maximum Frequency Accuracy across Frequencies

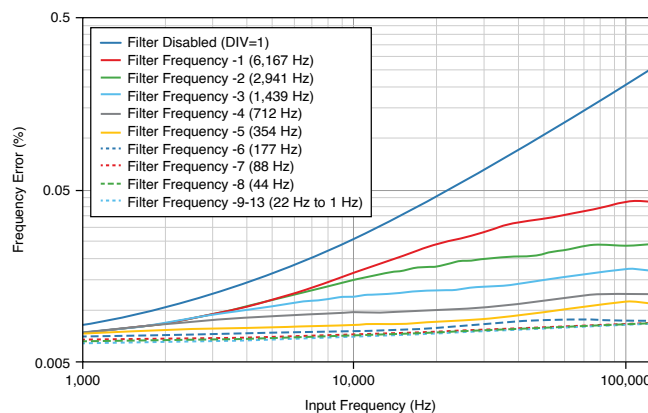
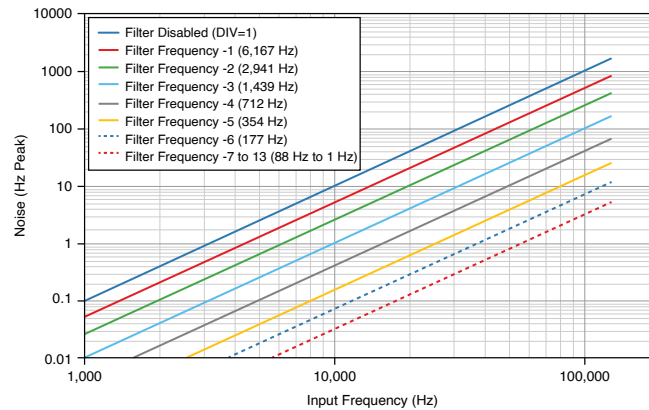

Figure 18. Frequency Noise



Crosstalk



Note Crosstalk is improved by >13 dB if measurement channel skips one channel from aggressor channel.

1. Sine wave (VR sensor crosstalk with source impedance at victim channels)

Figure 19. VR Sensor Crosstalk

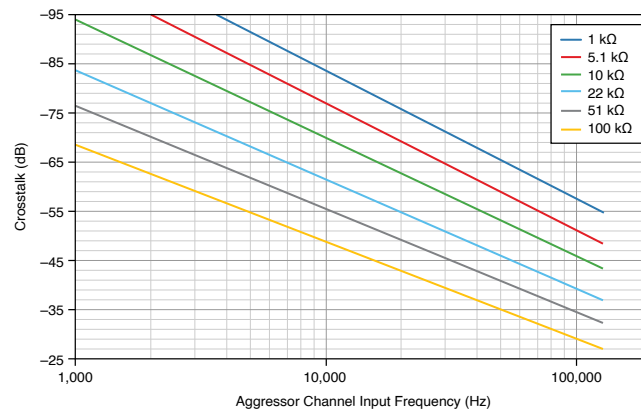

2. Square wave (Hall-effect sensor and encoder crosstalk with source impedance at victim channels)

- $[6.55 \times \text{LN}(\text{Sensor Impedance}) - 94.7]$ dB

Power Requirements

Power consumption from chassis	
Active mode	0.89 W maximum
Sleep mode	53 μ W maximum
Thermal dissipation (at 70 °C)	
Active mode	1.44 W maximum
Sleep mode	0.66 W maximum

Physical Characteristics

Dimensions	Visit ni.com/dimensions and search by module number.
Weight	170 g (6.0 oz)

NI-9326 Safety Voltages

Connect only voltages that are within the following limits:

Channel-to-channel isolation	
Continuous	150 V RMS, Measurement Category I
Withstand	1,000 V RMS, verified by a 5 s dielectric withstand test
Channel-to-earth ground isolation	
Continuous	150 V RMS, Measurement Category I

Withstand	1,000 V RMS, verified by a 5 s dielectric withstand test
-----------	--

Warning Do not connect the product to signals or use for measurements within Measurement Categories II, III, or IV, or for measurements on MAINS circuits or on circuits derived from Overvoltage Category II, III, or IV which may have transient overvoltages above what the product can withstand. The product must not be connected to circuits that have a maximum voltage above the continuous working voltage, relative to earth or to other channels, or this could damage and defeat the insulation. The product can only withstand transients up to the transient overvoltage rating without breakdown or damage to the insulation. An analysis of the working voltages, loop impedances, temporary overvoltages, and transient overvoltages in the system must be conducted prior to making measurements.

Mise en garde Ne pas connecter le produit à des signaux dans les catégories de mesure II, III ou IV et ne pas l'utiliser pour des mesures dans ces catégories, ou des mesures sur secteur ou sur des circuits dérivés de surtensions de catégorie II, III ou IV pouvant présenter des surtensions transitoires supérieures à ce que le produit peut supporter. Le produit ne doit pas être raccordé à des circuits ayant une tension maximale supérieure à la tension de fonctionnement continu, par rapport à la terre ou à d'autres voies, sous peine d'endommager et de compromettre l'isolation. Le produit peut tomber en panne et son isolation risque d'être endommagée si les tensions transitoires dépassent la surtension transitoire nominale. Une analyse des tensions de fonctionnement, des impédances de boucle, des surtensions temporaires et des surtensions transitoires dans le système doit être effectuée avant de procéder à des mesures.

Measurement Category I is for measurements performed on circuits not directly connected to the electrical distribution system referred to as **MAINS** voltage. MAINS is a hazardous live electrical supply system that powers equipment. This category is for measurements of voltages from specially protected secondary circuits. Such

voltage measurements include signal levels, special equipment, limited-energy parts of equipment, circuits powered by regulated low-voltage sources, and electronics.



Note Measurement Categories CAT I and CAT O are equivalent. These test and measurement circuits are for other circuits not intended for direct connection to the MAINS building installations of Measurement Categories CAT II, CAT III, or CAT IV.

Hazardous Locations

U.S. (UL)	Class I, Division 2, Groups A, B, C, D, T4; Class I, Zone 2, AEx nA IIC T4 Gc
Canada (C-UL)	Class I, Division 2, Groups A, B, C, D, T4; Ex nA IIC T4 Gc
Europe (ATEX) and International (IECEx)	Ex nA IIC T4 Gc DEMKO 12 ATEX 1202658X IECEx UL 14.0089X

Safety Compliance and Hazardous Locations Standards

This product is designed to meet the requirements of the following electrical equipment safety standards for measurement, control, and laboratory use:

- IEC 61010-1, EN 61010-1
- UL 61010-1, CSA C22.2 No. 61010-1
- EN 60079-0, EN 60079-15
- IEC 60079-0: Ed 6, IEC 60079-15; Ed 4
- UL 60079-0; Ed 6, UL 60079-15; Ed 4
- CSA C22.2 No. 60079-0, CSA C22.2 No. 60079-15



Note For safety certifications, refer to the product label or the [Product Certifications and Declarations](#) section.

Electromagnetic Compatibility Standards

This product meets the requirements of the following EMC standards for electrical equipment for measurement, control, and laboratory use:

- EN 61326-1 (IEC 61326-1): Class A emissions; Industrial immunity
- EN 55011 (CISPR 11): Group 1, Class A emissions
- AS/NZS CISPR 11: Group 1, Class A emissions



Note Group 1 equipment (per CISPR 11) is any industrial, scientific, or medical equipment that does not intentionally generate radio frequency energy for the treatment of material or inspection/analysis purposes.



Note In the United States (per FCC 47 CFR), Class A equipment is intended for use in commercial, light-industrial, and heavy-industrial locations. In Europe, Canada, Australia and New Zealand (per CISPR 11) Class A equipment is intended for use only in heavy-industrial locations.

CE Compliance

This product meets the essential requirements of applicable European Directives, as follows:

- 2014/30/EU; Electromagnetic Compatibility Directive (EMC)
- 2011/65/EU; Restriction of Hazardous Substances (RoHS)
- 2014/34/EU; Potentially Explosive Atmospheres (ATEX)

Product Certifications and Declarations

Refer to the product Declaration of Conformity (DoC) for additional regulatory compliance information. To obtain product certifications and the DoC for NI

products, visit ni.com/product-certifications, search by model number, and click the appropriate link.

Shock and Vibration

To meet these specifications, you must panel mount the system.

Operating vibration	
Random	5 g RMS, 10 Hz to 500 Hz
Sinusoidal	5 g, 10 Hz to 500 Hz
Operating shock	30 g, 11 ms half sine; 50 g, 3 ms half sine; 18 shocks at 6 orientations

Environmental

Refer to the manual for the chassis you are using for more information about meeting these specifications.

Operating temperature (IEC 60068-2-1, IEC 60068-2-2)	-40 °C to 70 °C
Storage temperature (IEC 60068-2-1, IEC 60068-2-2)	-40 °C to 85 °C
Ingress protection	IP40
Operating humidity (IEC 60068-2-30)	10% RH to 90% RH, noncondensing
Storage humidity (IEC 60068-2-30)	5% RH to 95% RH, noncondensing
Pollution Degree	2
Maximum altitude	5,000 m

Indoor use only.

Environmental Management

NI is committed to designing and manufacturing products in an environmentally responsible manner. NI recognizes that eliminating certain hazardous substances from our products is beneficial to the environment and to NI customers.

For additional environmental information, refer to the **Engineering a Healthy Planet** web page at ni.com/environment. This page contains the environmental regulations and directives with which NI complies, as well as other environmental information not included in this document.

EU and UK Customers

-  Waste Electrical and Electronic Equipment (WEEE)—At the end of the product life cycle, all NI products must be disposed of according to local laws and regulations. For more information about how to recycle NI products in your region, visit ni.com/environment/weee.

电子信息产品污染控制管理办法 (中国 RoHS)

-  中国 RoHS— NI 符合中国电子信息产品中限制使用某些有害物质指令(RoHS)。关于 NI 中国 RoHS 合规性信息，请登录 ni.com/environment/rohs_china。(For information about China RoHS compliance, go to ni.com/environment/rohs_china.)

¹ Threshold setting between 10% to 90% of signal amplitude and for unsaturated square wave (<25 Vpp) only.

² Settled to 99% of final value.