

SHARP

OPTO-ELECTRONIC DEVICES DIVISION
ELECTRONIC COMPONENTS GROUP
SHARP CORPORATION

SPECIFICATION

DEVICE SPECIFICATION FOR

1 Bit Output Type Distance Measuring Sensor

MODEL No.

GP2Y0D810Z0F

Specified for

Enclosed please find copies of the Specifications which consists of 9 pages including cover.
After confirmation of the contents, please be sure to send back copies of the Specifications
with approving signature on each.

CUSTOMER'S APPROVAL

DATE

BY

PRESENTED

DATE

BY

H. O.
H. Ogura,
Department General Manager of
Engineering Dept., III
Opto-Analog Devices Division
ELECOM Group
SHARP CORPORATION

Product name : 1 bit output distance measuring sensor

Model No. : GP2Y0D810Z0F

1. These specification sheets include materials protected under copyright of Sharp Corporation ("Sharp"). Please do not reproduce or cause anyone to reproduce them without Sharp's consent.
2. When using this product, please observe the absolute maximum ratings and the instructions for use outlined in these specification sheets, as well as the precautions mentioned below. Sharp assumes no responsibility for any damage resulting from use of the product which does not comply with the absolute maximum ratings and the instructions included in these specification sheets, and the precautions mentioned below.

(Precautions)

- (1) This product is designed for use in the following application areas ;

• Computers • OA equipment • Telecommunication equipment (Terminal)
• Measuring equipment • Tooling machines • Audio visual equipment
• Home appliances

If the use of the product in the above application areas is for equipment listed in paragraphs (2) or (3), please be sure to observe the precautions given in those respective paragraphs.

- (2) Appropriate measures, such as fail-safe design and redundant design considering the safety design of the overall system and equipment, should be taken to ensure reliability and safety when this product is used for equipment which demands high reliability and safety in function and precision, such as ;

• Transportation control and safety equipment (aircraft, train, automobile etc.)
• Traffic signals • Gas leakage sensor breakers • Rescue and security equipment
• Other safety equipment .

- (3) Please do not use this product for equipment which require extremely high reliability and safety in function and precision, such as ;

• Space equipment • Telecommunication equipment (for trunk lines)
• Nuclear power control equipment • Medical equipment.

- (4) Please contact and consult with a Sharp sales representative if there are any questions regarding interpretation of the above three paragraphs.

3. Please contact and consult with a Sharp sales representative for any questions about this product.

1. Application

This specification applies to the outline and characteristics of the 1 bit output distance measuring sensor ;
Model No. GP2Y0D810Z0F.

2. Outline

Refer to the attached drawing No. CY13405i02

3. Ratings and characteristics

Refer to the attached sheet, page 4, 5.

4. Reliability

Refer to the attached sheet, Page 6.

5. Outgoing inspection

Refer to the attached sheet, Page 6.

6. Supplements

6-1 GP2Y0D805Z0F Example of Output distance characteristics

Refer to the attached sheet, page 7.

6-2 This product shall not contain the following materials.

Also, the following materials shall not be used in the production process for this product.

Materials for ODS : CFCs, Halon, Carbon tetrachloride 1,1,1-Trichloroethane (Methyl chloroform)

6-3 This manufacture does not contain the chemical materials regulated by RoHS directive,

(except for the parts NOT regulated by RoHS)

6-4 Product mass : Approx. 0.7g

7. Notes

Refer to the attached sheet, page 8.

2. Outline

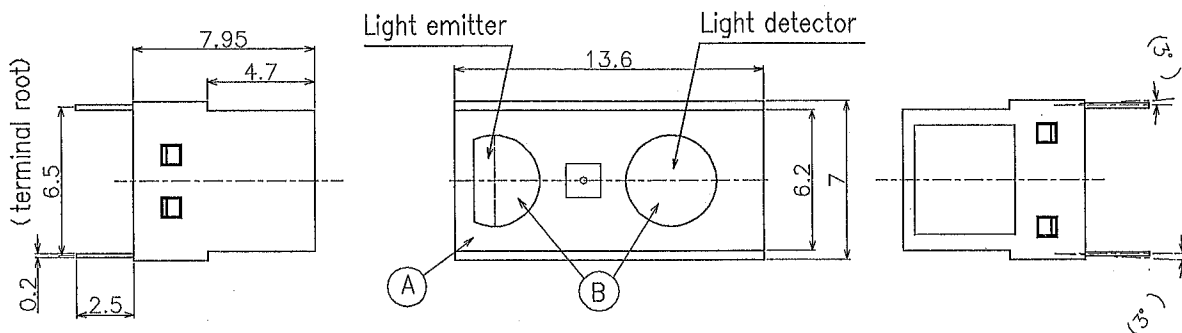

端子名	端子名
①	Cathode
②	LED_FB
③	LED
④	GND
⑤	—
⑥	—
⑦	REG
⑧	—
⑨	—
⑩	—
⑪	Vcc
⑫	Vin
⑬	Vo
⑭	Anode

- : No contact

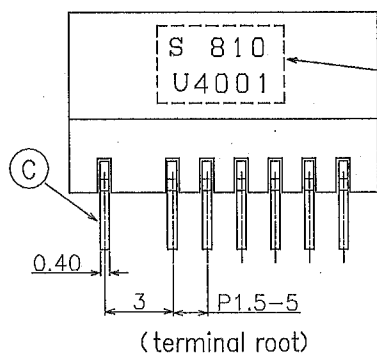

Stamp (Example)

SHARP : [S]
S 805 GP2Y0D810Z0F
: I810J
U 4 0 0 1 LOT No.
Month (1 to 9, 0, N, D)
(DIN Standard symbol)
Year (DIN Standard symbol)

DIN Standard year production
(Remove G, I, O, Q, Y, Z)
(It repeats itself by a period for 20 years)

西曆	記号
2006	U
2007	V
2008	W
2009	X
⋮	⋮
2025	T
2026	U

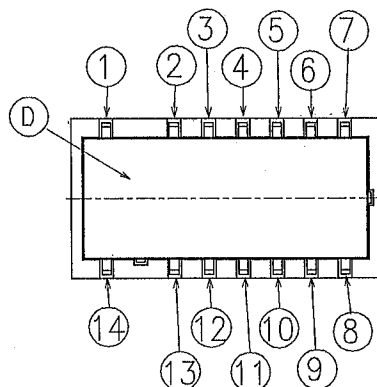

Material

A	Case	PC (Color:Black)
B	Lens	PC(Visible light cut type)
C	Device coating	PPS(Color:Black)
D	Lead pin	42ALLOY (Pd-Au plating)

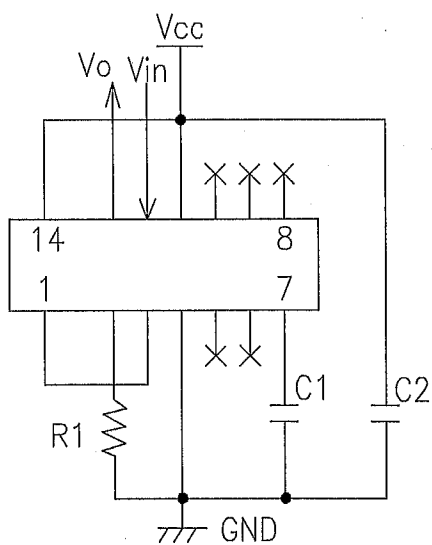

C1 · C2 = 0.1 μF

(Note1) Unspecified tolerances shall be ±0.3mm.

(Note2) () : Reference value

Unit: mm Scale: 3/1

Name	GP2Y0D810Z0F Outline Dimensions
Drawing No.	CY13405i02

3-1 Schematic

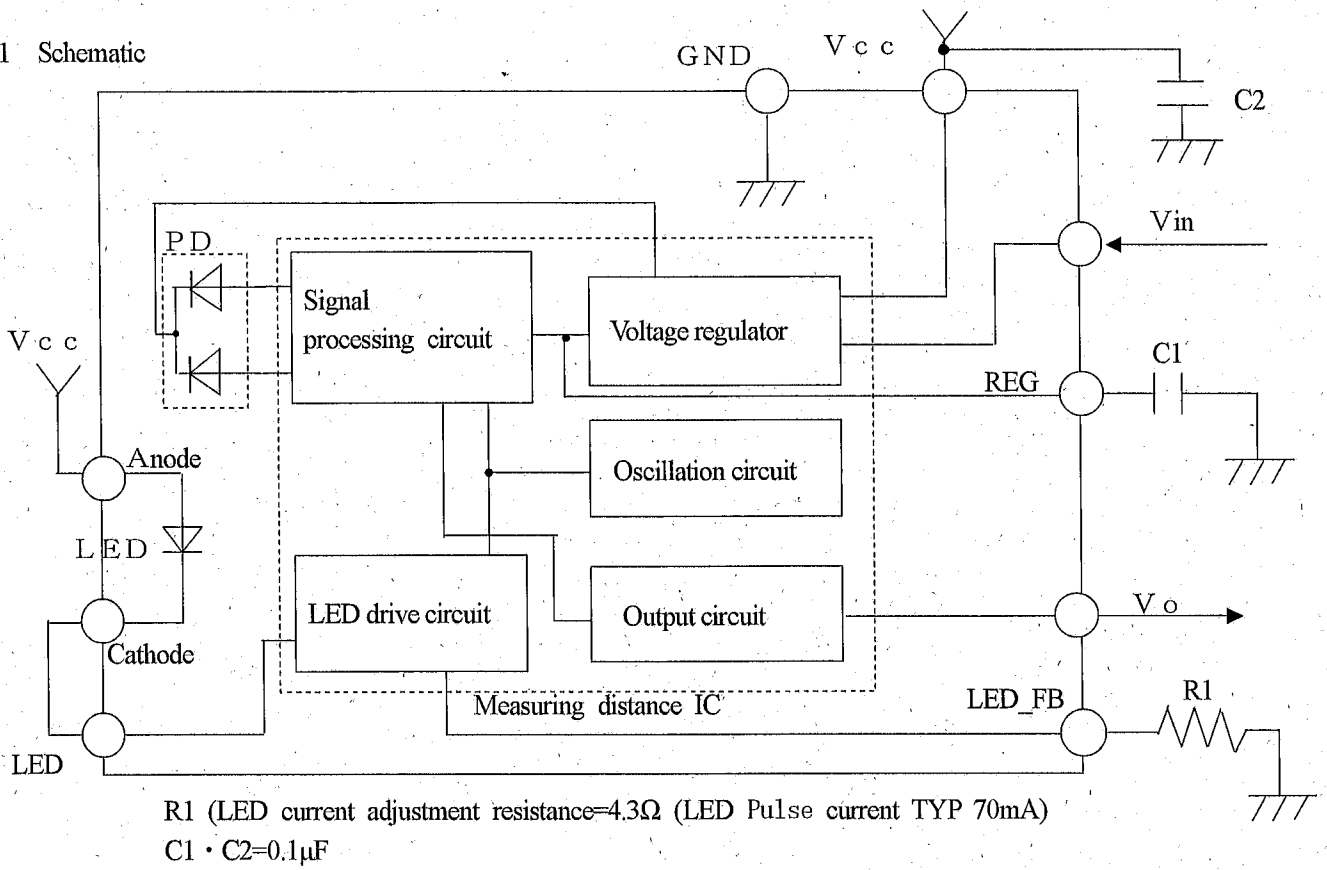

3-2 Absolute maximum ratings

Parameter	Symbol	Ratings	Unit	Remark
Supply voltage	Vcc	-0.3 to +7	V	-
Output terminal voltage	Vo	-0.3 to Vcc+0.3	V	-
Input terminal voltage	Vin	-0.3 to Vcc+0.3	V	-
Operating temperature	Topr	-10 to +60	°C	-
Storage temperature	Tstg	-20 to +70	°C	-
Soldering temperature	Tsol	260	°C	5s or less/time up 2 times t=1.0mm One side board mounting

Recommended operating conditions

Parameter	Symbol	Rating	Unit	Remark
Supply voltage	Vcc	2.7 to 6.2	V	-
High level input voltage	VinH	MIN Vcc-0.2	V	CMOS level signal. Operating
Low level input voltage	VinL	MAX 0.2	V	CMOS level signal. Standby state

3-3 Electro-optical Characteristics

(Ta=25°C, Vcc=5V)

Parameter	Symbol	Conditions	MIN.	TYP.	MAX.	Unit
Output terminal voltage	VoH	Output voltage at high level	Vcc-0.6	-	-	V
	VoL	Output voltage at low level	-	-	0.6	V
Output distance characteristics	Vo	(*1) (*2)	80	100	130	mm
Average supply current	Icc 1	Vcc=5V Vin=5V R1=4.3Ω (*3)	-	5	6.5	mA
Average supply current	Icc 2	Vcc=5V Vin=5V R1=4.3Ω (*3)	-	9	10.5	mA
Stand-by supply current	Icc 3	Vcc=5V Vin=0V	-	5	8	μA

※ L: Distance to reflective object

(*1) Using reflective object: White paper (Made by Kodak Co., Ltd. gray cards R-27*white face, reflectance ; 90%)

(*2) Output switching has a hysteresis width.

The distance specified by Vo should be the one with which the output H switches to the output L.

(*3) Icc1:(LED Emitting time:TYP20 μs*8times) Icc2:(Emitting time:TYP20 μs*15times)
LED Pulse Current:TYP 70mA

3-4 Timing chart

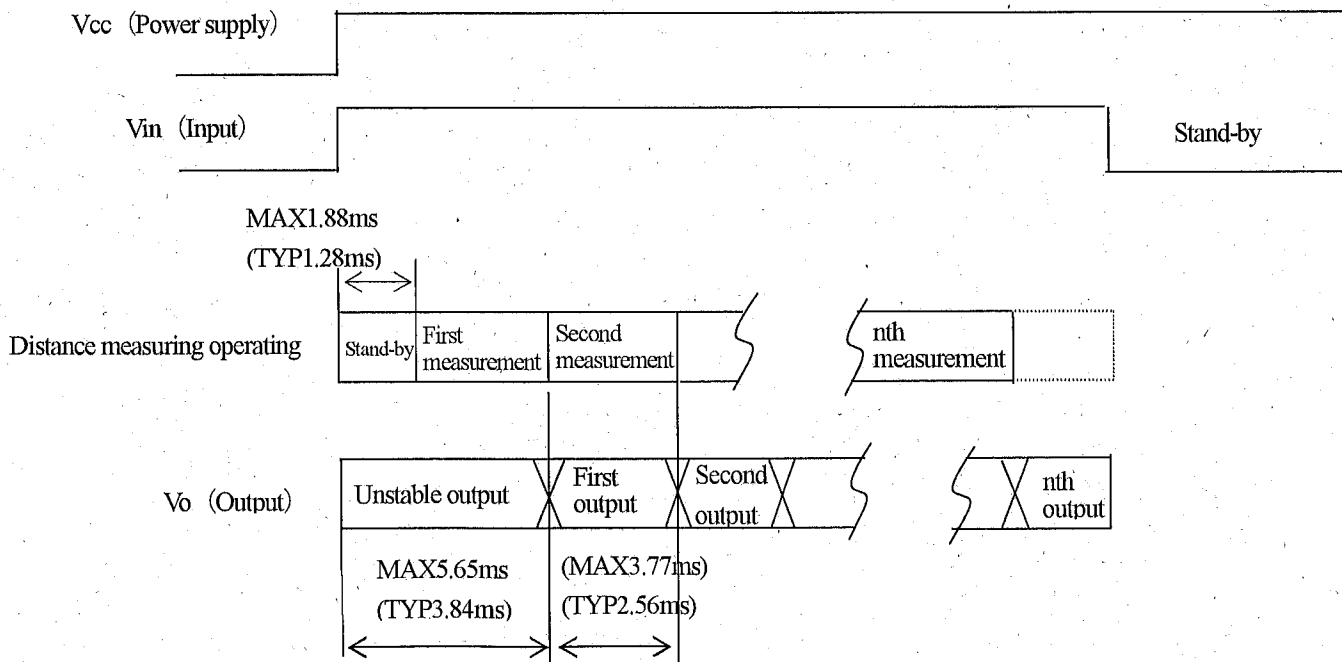

4. Reliability

The reliability of products shall be satisfied with items listed below.

Confidence level : 90%
 LTPD : 20 or 30

No.	Test Items	Test Conditions	Failure Judgement Criteria	Samples (n)
				Defective (c)
1	Temperature cycling	1 cycle -20°C to +70°C (30min.) (30min.) 25 cycle test	Initial × 0.8 > Vo Vo > Initial × 1.2 (Note 1)	n=11, c=0
2	High temp. and high humidity storage	+40°C, 90%RH, 500h		n=11, c=0
3	High temp. storage	+70°C, 500h		n=11, c=0
4	Low temp. storage	-20°C, 500h		n=11, c=0
5	Operation life (High temp.)	+60°C, Vcc=5V, 500h		n=11, c=0
6	Soldering heat	Tsol=260°C, 5s or less/time up 2 times t=1.0mm One side borad mounting		n=11, c=0
7	Mechanical shock	1000m/s ² , 6.0ms 3times/±X, ±Y, ±Z direction		n=8, c=0
8	Variable frequency vibration	10 to 55 to 10Hz/1min. 2h/X, Y, Z direction overall amplitude : 1.5mm		n=8, c=0

(Note 1) Test conditions are according to 3-3 Electro-optical characteristics.

(Note 2) After test, measurement shall be carried out after leaving under the normal temperature and the normal humidity for two hours. But no dew drop.

5. Outgoing inspection

(1) Inspection lot

Inspection shall be carried out per each delivery lot.

(2) Inspection items

A single sampling plan, normal inspection level II based on ISO 2859 is applied.

The AQL according to the inspection items are shown below.

Defect	Inspection item	AQL (%)
Major defect	Electro-optical characteristics defect (In para. 3-3)	0.4
Minor defect	Defect on appearance and dimension ※ Crack, chip, scratch, stain	1.0

※ Crack, chip, scratch, stain

One which affects the characteristics of para. 3-3 shall be defect.

6-1. GP2Y0D810Z0F Example of Output distance characteristics

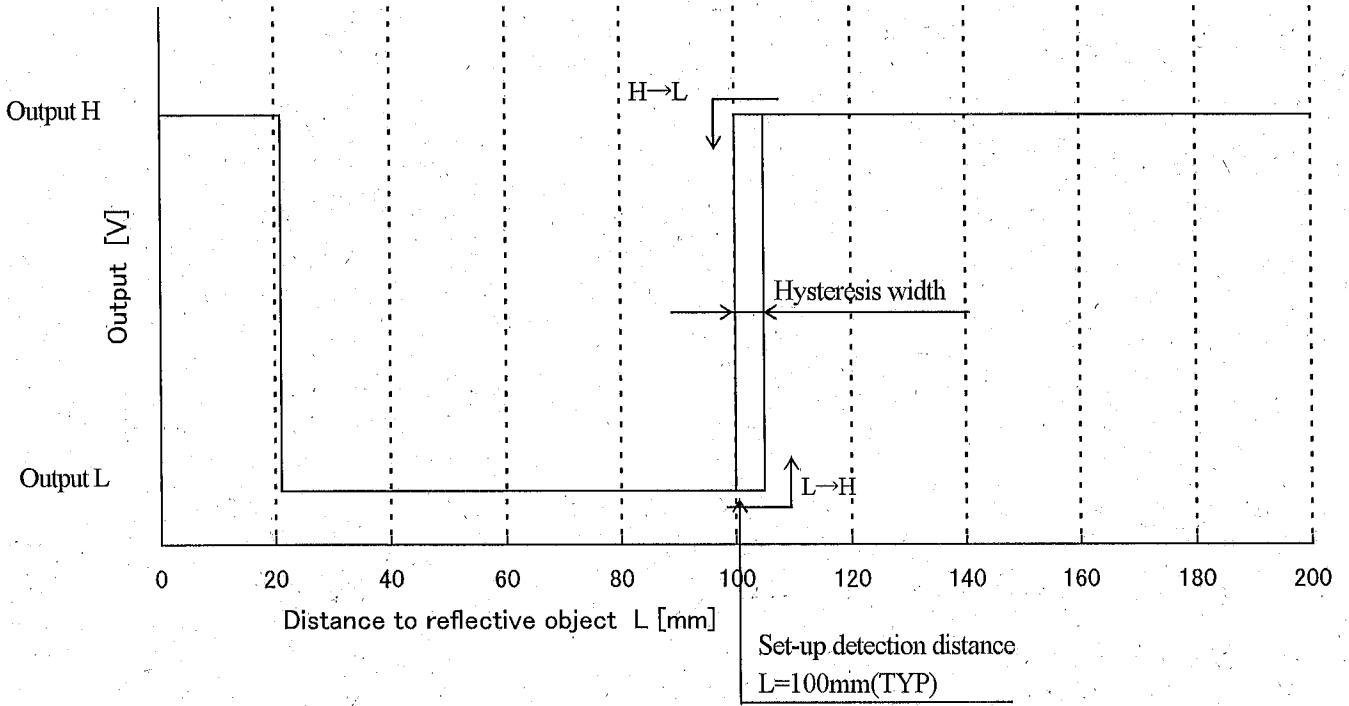

7. Notes

[Advice for the optics]

7-1 Lens of this device shall be kept cleanly. There are cases that dust, water or oil and so on deteriorate the characteristics of this device. Please consider it at actual application.

7-2 In case that protection is set in front of the emitter and detector portion, the protection cover which has the most efficient transmittance at the emitting wavelength range of LED for this product ($\lambda=870\text{nm}\pm 50\text{nm}$), shall be recommended to use. The face and back of protection cover should be mirror polishing. Also, as there are cases that the characteristics may not be satisfied with according to the distance between the protection cover and this product or the thickness of the protection cover, please use this product after confirming the operation sufficiently in actual application.

[Advice for the characteristics]

7-3 In case that there is an object near to light exits of the sensor between the sensor and the detected object, please use this device after confirming sufficiently whether the characteristics of this sensor do not change by the object.

7-4 When the detector surface receive direct light from the sun, tungsten lamp and so on, there are cases that the distance can not be measured exactly. Please consider the design that the detector does not receive direct light from such light source.

7.5 Distance between sensor and mirror reflector can not sometimes measure exactly.
By changing the mounting angle of this product, it may measure the distance exactly.

7.6 In case that reflective object has boundary line clearly, there is cases that distance can not measure exactly.
At that time, if direction of boundary line and the line between emitter center and detector center are parallels, it is possible to decrease deviation of measuring distance.

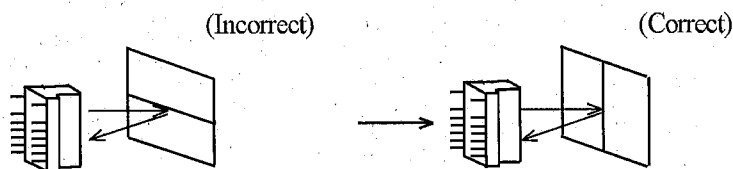

7-7 In order to decrease measuring error due to moving direction of object, we recommend that the sensor be mounted like the drawing below.

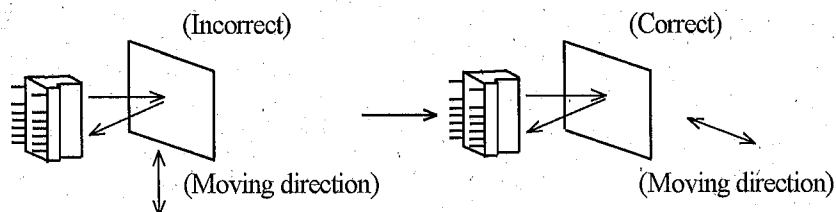

[Notes on handling]

7-8 Please don't do washing. Washing may deteriorate the characteristics of optical system and so on.
Please confirm resistance to chemicals under the actual usage since this product has not been designed against washing.

7-9 Soldering shall be done with a soldering iron and below 300°C, less than 5s and maximum 2 times.
Also, please pay attention not to put outer force on lead terminals while soldering.
Please do not apply flow soldering because it may damage optical lens of the device.