

---

**PIC32MK MCA Curiosity Pro User Guide**

---

**EV15D86A**

---

This document describes the Microchip PIC32MK MCA Curiosity Pro development board (EV15D86A) features, functionality, and schematics. The PIC32MK MCA Curiosity Pro development board includes an integrated programmer or debugger, and requires no additional hardware to get started. With expansion boards, EV15D86A provides the freedom to develop for a variety of applications,

**Figure 1. PIC32MK MCA Curiosity Pro Development Board**

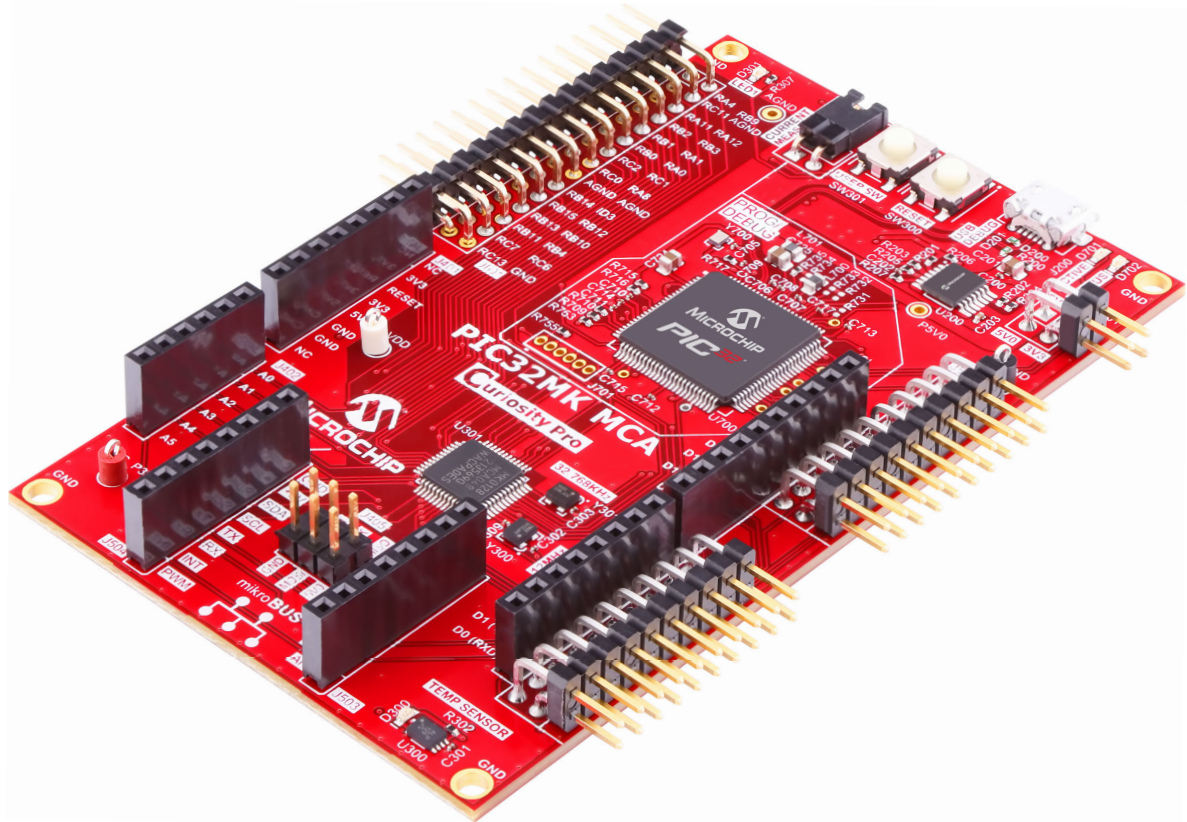

## Table of Contents

EV15D86A.....	1
1. Introduction.....	3
1.1. PIC32MK MCA Curiosity Pro Features.....	3
1.2. Kit Contents.....	3
2. PIC32MK MCA Curiosity Pro Development board Functionality and Features.....	4
2.1. PIC32MK MCA Curiosity Pro Development board Feature Location.....	4
2.2. System Block Diagram.....	5
2.3. Power Block Diagram.....	7
2.4. mikroBUS™ Socket.....	7
2.5. Xplained Pro Standard Extension Header.....	8
2.6. Motor Control Interface.....	9
2.7. Arduino Uno R3 Interface.....	10
2.8. Button and LED.....	11
2.9. PICKit™ On-Board 4 .....	11
2.10. Recovery Method.....	12
2.11. Demonstration Firmware Application.....	13
3. Hardware.....	16
3.1. Schematics.....	0
3.2. Bill of Materials.....	24
4. Revision History.....	27
The Microchip Website.....	28
Product Change Notification Service.....	28
Customer Support.....	28
Microchip Devices Code Protection Feature.....	28
Legal Notice.....	29
Trademarks.....	29
Quality Management System.....	30
Worldwide Sales and Service.....	31

## 1. Introduction

The PIC32MK MCA Curiosity Pro development board includes an integrated programmer or debugger, and requires no additional hardware to get started. Users can expand functionality through Arduino Uno R3, Mikro Bus, or Xplained Pro compatible expansion boards, and control a 3-phase inverter to drive a 3-phase BLDC, PMSM, and ACIM motor.

With expansion boards, the PIC32MK MCA Curiosity Pro development board provides the freedom to develop for a variety of applications, including Bluetooth Audio, Internet of Things (IoT), robotics development, and proof-of-concept designs. All requisite control input and output signals relevant for a 3-phase motor control application are brought to a single header which can interface to a 3-Phase Inverter board.

### 1.1 PIC32MK MCA Curiosity Pro Features

The following are key features of the PIC32MK MCA Curiosity Pro development board:

- PIC32MK0128MCA048, 120 MHz, 128 KB Flash, 32 KB SRAM
- On-Board debugger (PKoB4)
  - Real-time Programming and Debugging
  - Virtual COM port (VCOM)
  - Data Gateway Interface (DGI)
- Arduino Uno R3 compatible interface
- Xplained pro extension compatible interface
- Motor Control interface
- MikroBus™ Socket
- On-Board Temperature Sensor
- User button
- User LED

### 1.2 Kit Contents

The kit contains one PIC32MK MCA Curiosity Pro development board, EV15D86A.

**Note:** If you are missing any part of a kit, contact a Microchip sales office for assistance. A list of Microchip offices for sales and service is provided on the last page of this document.

## 2. PIC32MK MCA Curiosity Pro Development board Functionality and Features

### 2.1 PIC32MK MCA Curiosity Pro Development board Feature Location

Figure 2-1. PIC32MK MCA Curiosity Pro Development Board Layout (Top View)

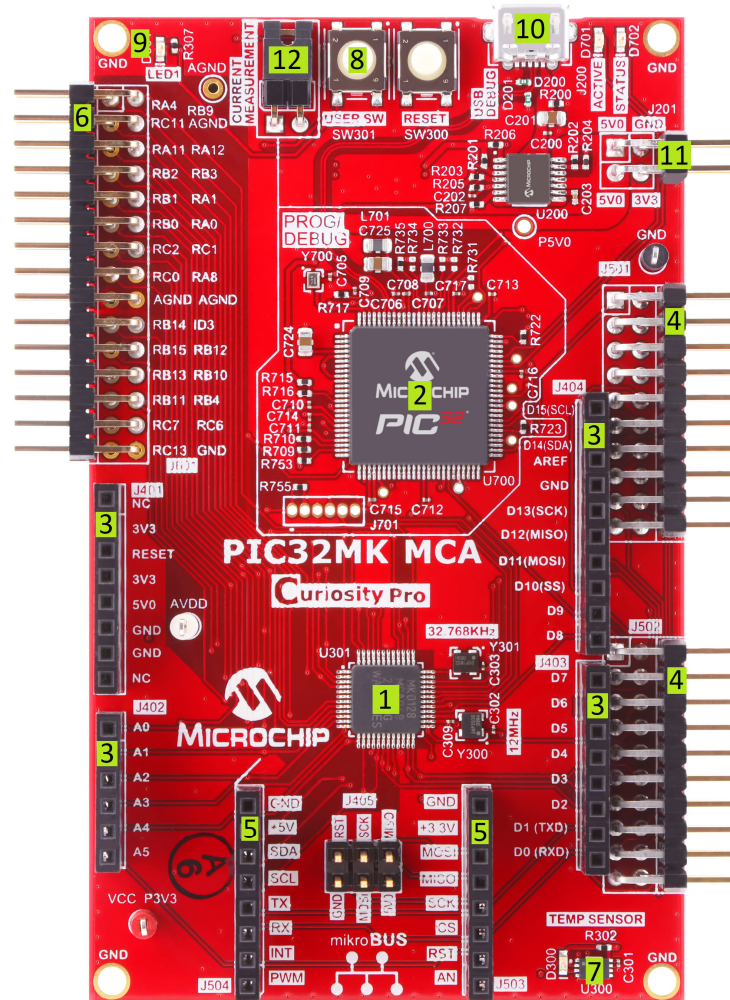

Table 2-1. PIC32MK MCA Curiosity Pro Development Board Features and Location

Number	Description of item
1	PIC32MK0128MCA048
2	PICKit on Board 4 (PKoB4)
3	Arduino Uno interface
4	Xplained Pro expansion compatible interface
5	mikroBUS™ Socket
6	Motor Control Interface

.....continued	
Number	Description of item
7	On-board temperature sensor
8	Programmable user buttons
9	User LED
10	USB to PKoB4 for debugging, power, virtual COM port
11	External 5V supply header
12	Current measurement header

**Table 2-2. PIC32MK MCA Microchip Total System Solutions (TSS)**

TSS Component	Qty (per board)	Function
TN2106K1-G	3	N-Channel MOSFET
MIC2042-1YTS	1	Power switch
MIC5528-3.3YMT-TR	2	LDO
MCP9808T-E/MC	1	Temperature Sensor
PIC32MK0128MCA048-I/Y8X	1	MCU
ATSAME70N21B-ANT	1	PKoB MCU
24LC256T-E/ST	1	Serial EEPROM
DSC1001DL5-012.0000	1	12 MHz Osc
DSC6111JI2B-032K768	1	32.768 kHz
DSC6011HI1B-012.0000	1	12 MHz Osc

## 2.2 System Block Diagram

The figure below illustrates a high-level block diagram of the PIC32MK MCA Curiosity Pro development board.

Figure 2-2. PIC32MK MCA Curiosity Pro Block Diagram

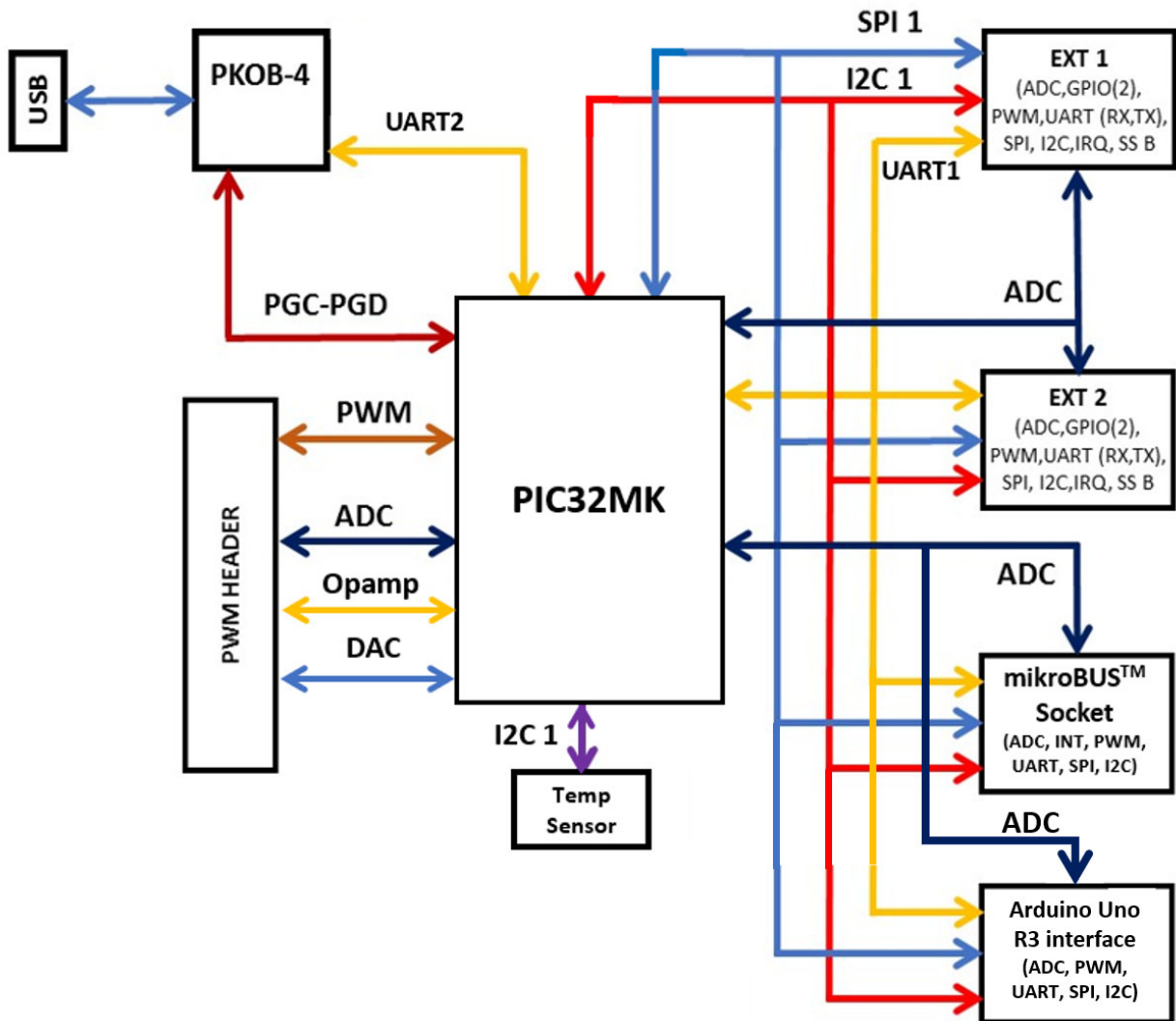

## 2.3 Power Block Diagram

The figure below illustrates a high-level block diagram of the power system on the PIC32MK MCA Curiosity Pro development board. The development board can be powered through a 5V supply available from the USB connector for the PKoB4 debugger or through an external 5V or 3.3V supply which can be connected through a 2 x 2 header, J2.

Figure 2-3. PIC32MK MCA Curiosity Pro Power Block Diagram

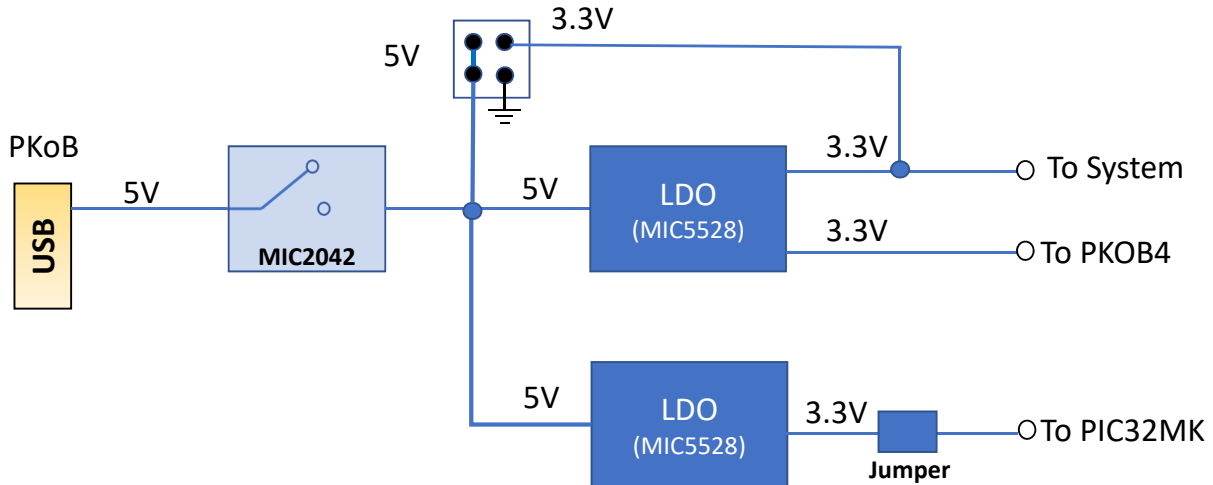

## 2.4 mikroBUS™ Socket

One mikroBUS socket, J503-J504, is available on the development board. This socket can be used to expand the functionality using the MikroElektronika Click boards™. The mikroBUS connector consists of two 1x8 female headers with SPI, I<sup>2</sup>C, UART, RST, PWM, analog, and interrupt lines as well as 3.3V, 5V, and GND power lines.

Table 2-3. mikroBUS Socket Pinout

mikroBUS Pin Number	mikroBUS Pin Name	Description	Port
1	AN	Analog	RA1
2	RST	Reset	RC2
3	CS	SPI Chip Select	RA4
4	SCK	SPI Clock	RB7
5	MISO	SPI Host In Client Out	RC7
6	MOSI	SPI Host Out Client In	RA11
7	+3.3V	VCC-3.3V power	VCC_P3V3
8	GND	Reference Ground	GND
9	GND	Reference Ground	GND
10	+5V	VCC-5V power	P5V0
11	SDA	I <sup>2</sup> C Data	RA8
12	SCL	I <sup>2</sup> C Clock	RB4
13	TX	UART Transmit	RC0

.....continued			
mikroBUS Pin Number	mikroBUS Pin Name	Description	Port
14	RX	UART Receive	RC1
15	INT	Hardware Interrupt	RC8
16	PWM	PWM Output	RB12

## 2.5 Xplained Pro Standard Extension Header

The PIC32MK MCA Curiosity Pro development board has two Xplained Pro compatible interfaces that enables use of existing expansion boards. Each interface consists of a dual-row, 30-pin, 100 mil, 90 degree extension male headers, while Xplained Pro extensions have their female counterparts. The extension headers can be used to connect a variety of Xplained Pro extension boards or to access the pins of the target MCU.

**Note:** All pins are not always connected.

The Pinout description for the Xplained Pro Standard Extension Header1 and Header 2 are listed in the following tables.

**Table 2-4. Xplained Pro Header1 Pinout**

Pin number	Name	Description	Port
1	ID_EXT1	Communication line to the ID chip on an extension board	Connected to PKoB4
2	GND	Ground	-
3	ADC0(+)	Analog-to-digital converter, alternatively positive part of differential ADC	RA0
4	ADC0(-)	Analog-to-digital converter, alternatively negative part of differential ADC	RB0
5	GPIO1	General purpose I/O	RB1
6	GPIO2	General purpose I/O	RB2
7	PWMH1	High-Side PWM	RB14
8	PWML1	Low-Side PWM	RB15
9	GPIO3	General purpose I/O	RB10
10	GPIO4	General purpose I/O	RB11
11	SDA2	Data line for I <sup>2</sup> C interface. Always implemented, bus type	RA8
12	SCL2	Clock line for I <sup>2</sup> C interface. Always implemented, bus type.	RB4
13	RX2	Receiver line of target device UART	RC1
14	TX2	Transmitter line of target device UART.	RC0
15	SS2	SPI Select or General purpose I/O	RD8
16	MOSI	Host Out Client In (MOSI) line of serial peripheral interface. Always implemented, bus type.	RA11
17	MISO	Host In Client Out (MISO) line of serial peripheral interface. Always implemented, bus type.	RC7
18	SCK2	Clock for serial peripheral interface. Always implemented, bus type	RB7
19	GND	Ground	-
20	VCC	Power for extension boards (3.3V)	-



Table 2-5. Xplained Pro Header2 Pinout

Pin number	Name	Description	Port
1	ID_EXT2	Communication line to the ID chip on an extension board	Connected to PKoB4
2	GND	Ground	-
3	ADC1(+)	Analog-to-digital converter, alternatively positive part of differential ADC	RA1
4	ADC1(-)	Analog-to-digital converter, alternatively negative part of differential ADC	RB3
5	GPIO5	General purpose I/O	RC2
6	GPIO6	General purpose I/O	RA4
7	PWMH2	High-Side PWM	RB12
8	PWML2	Low-Side PWM	RB13
9	GPIO7	General purpose I/O	RC8
10	GPIO8	General purpose I/O	RC9
11	SDA2	Data line for I <sup>2</sup> C interface. Always implemented, bus type	RA8
12	SCL2	Clock line for I <sup>2</sup> C interface. Always implemented, bus type.	RB4
13	RX2	Receiver line of target device UART	RC1
14	TX2	Transmitter line of target device UART.	RC0
15	SS3	SPI Client Select or General purpose I/O	RC6
16	MOSI	Host Out Client In (MOSI) line of serial peripheral interface. Always implemented, bus type.	RA11
17	MISO	Host In Client Out (MISO) line of serial peripheral interface. Always implemented, bus type.	RC7
18	SCK2	Clock for serial peripheral interface. Always implemented, bus type	RB7
19	GND	Ground	-
20	VCC	Power for extension boards (3.3V)	-

## 2.6 Motor Control Interface

The PIC32MK MCA Curiosity Pro offers the ability to interface to a 3-Phase motor control driver board through a dual-row, 32-pin, 100 mil, 90 degree extension male header. The following table provides the function, description, and port on the MCU for the motor control interface header.

Table 2-6. Motor Control Extension Interface Pin Description

Pin	Name	Motor Control Function	I/O Function	Port
1	IA	Motor Phase A Current	Analog Input	RA4
2	IB	Motor Phase B Current	Analog Input	RB9
3	ISUM	Inverter DC Bus Current	Analog Input	RC11
4	GND	Analog Ground	N/A	AVSS
5	VBUS	DC Bus measurement	Analog Input	RA11
6	POT	Potentiometer Measurement	Analog Input	RA12
7	OA1IN+	Non-inverting input of OPAMP1	Analog Input	RB2

.....continued

Pin	Name	Motor Control Function	I/O Function	Port
8	OA1IN-	Inverting input of OPAMP1	Analog Input	RB3
9	OA1OUT	Output of OPAMP1	Analog Output	RB1
10	OA2IN+	Non-inverting input of OPAMP2	Analog Input	RA1
11	OA2IN-	Inverting input of OPAMP2	Analog Input	RB0
12	OA2OUT	Output of OPAMP2	Analog Output	RA0
13	OA3IN+	Non-inverting input of OPAMP3	Analog Input	RC2
14	OA3IN-	Inverting input of OPAMP3	Analog Input	RC1
15	OA3OUT	Output of OPAMP3	Analog Output	RC0
16	DAC1	Output of DAC1	Analog Output	RA8
17	AGND	Analog Ground	N/A	AVSS
18	AGND	Analog Ground	N/A	AVSS
19	PWMH1	High-Side PWM for Phase A	Digital Output	RB14
20	ID4	Identification pin connected to PKoB4	Digital Input	NC
21	PWML1	Low-Side PWM for Phase A	Digital Output	RB15
22	PWMH2	High-Side PWM for Phase B	Digital Output	RB12
23	PWML2	Low-Side PWM for Phase B	Digital Output	RB13
24	PWMH3	High-Side PWM for Phase C	Digital Output	RB10
25	PWML3	Low-Side PWM for Phase C	Digital Output	RB11
26	FLT15	Over-current Fault input	Digital Input	RB4
27	QEA1	Encoder Phase A signal	Digital Input	RC7
28	INDX1	Encoder Index signal	Digital Input	RC6
29	QEB1	Encoder Phase B signal	Digital Input	RC8
30	DGND	Digital Ground	N/A	VSS

## 2.7 Arduino Uno R3 Interface

The PIC32MK MCA Curiosity Pro development board has an Arduino Uno R3 compatible header which enables the use of Arduino shields. Peripherals, such as ADC, SPI, I<sup>2</sup>C, UART, and PWM of the PIC32MK MCA MCU can be interfaced with Arduino shields using the Arduino Uno R3 interface.

The pin map between the PIC32MK MCA device and the Arduino Uno R3 interface is given in the following table.

**Table 2-7. PIC32MK MCA and Arduino Uno R3 interface Pin Maps**

Arduino Uno R3 Pin Name	PIC32MK MCA Pin Name
A0	RA0
A1	RA1
A2	RB0
A3	RB1

.....continued	
Arduino Uno R3 Pin Name	PIC32MK MCA Pin Name
A4	RB2
A5	RC2
D0/RX	RC0
D1/TX	RC1
D2	RC9
D3	RB14
D4	RC8
D5	RB15
D6	RB12
D7	RB11
D8	RC15
D9	RB13
D10	RB10
D11	RA11
D12	RC7
D13	RB7
D18/SDA	RA8
D19/SCL	RB4

## 2.8 Button and LED

The PIC32MK MCA Curiosity Pro development board offers a user button and an LED. The following table provides the LED pin description, function, type, and port details on the MCU.

**Table 2-8. Button and LED Pin Description**

Function	Description	Type	Port
User SW	User Switch	Digital Input	RA7
User LED1	User LED	Digital Output	RA10

## 2.9 PICKit™ On-Board 4

The MPLAB® PICKit On-Board 4 (PKoB4) is a new generation In-Circuit Debugger. The MPLAB PKoB4 programs faster than its predecessor and is designed to use a high-speed 2.0 USB interface, which provides a feature rich debugging experience through one USB cable. The PKoB4 is intended to support programming, debugging, and a Data Gateway interface.

The MPLAB PKoB4 In-Circuit Debugger is compatible with these platforms:

- Microsoft Windows® 7 or later
- Linux®
- macOS™

The MPLAB PKoB4 In-Circuit Debugger system provides the following capabilities:

- Connects to computer through high-speed USB 2.0 (480 Mbits/s) cable
- Programs devices using MPLAB X IDE or MPLAB IPE
- Supports multiple hardware and software breakpoints, stopwatch, and source code file debugging
- Debugs application in real time
- Sets breakpoints based on internal events
- Monitors internal file registers
- Debugs at full speed
- Configures pin drivers
- Virtual COM Support which can establish UART communication between the Host PC and the target device using the following UART Configuration:
  - Baud rate: 115,200 bps
  - Only 8-bit character format
  - No hardware flow control
  - One stop-bit
- Field-upgradeable through an MPLAB X IDE firmware download
- Adds new device support and features by installing the latest version of MPLAB X IDE (available as a free download at <https://www.microchip.com/mplabx/>)
- Indicates debugger status through on-board LEDs

#### Performance/Speed:

- More and faster memory
- A Real-Time Operating System (RTOS)
- No firmware download delays incurred when switching devices
- A 32-bit MCU running at 300 MHz

## 2.10 Recovery Method

If PKoB4 becomes unresponsive, users can recover the tool by following these steps:

1. With the PIC32MK MCA Curiosity Pro development board still powered, short the 2 pads for approximately 10 seconds.

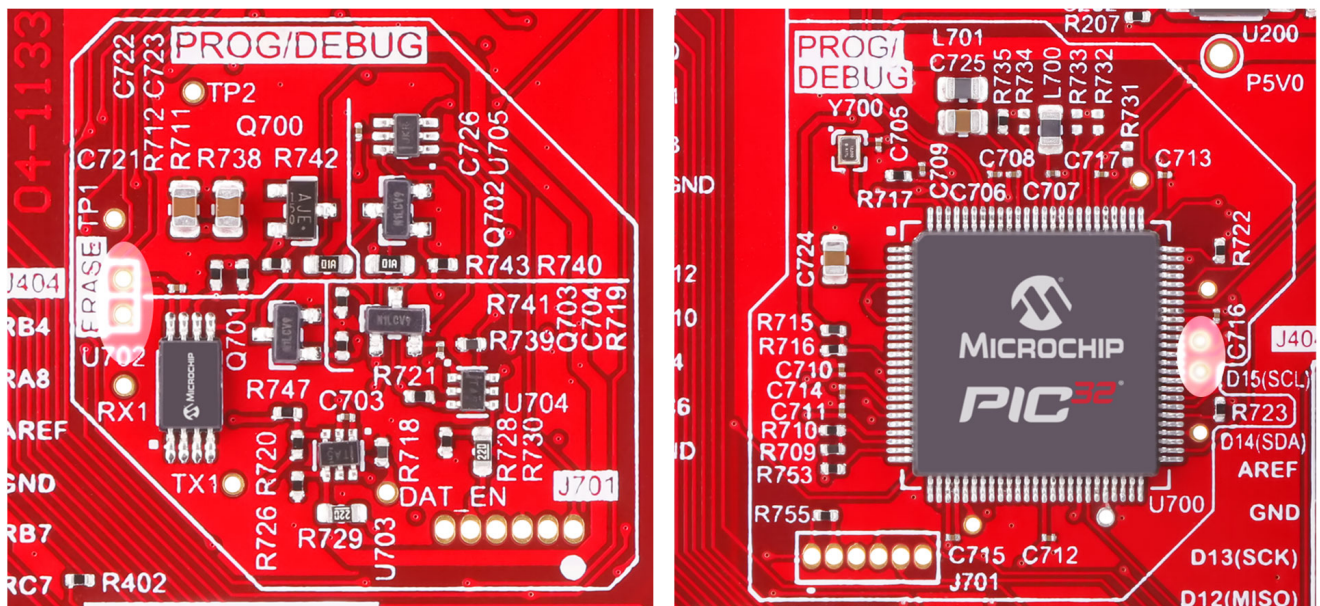

2. Open The latest version of MPLAB X IDE.
3. From *Debug > Hardware Tool Emergency Boot Firmware Recovery*.

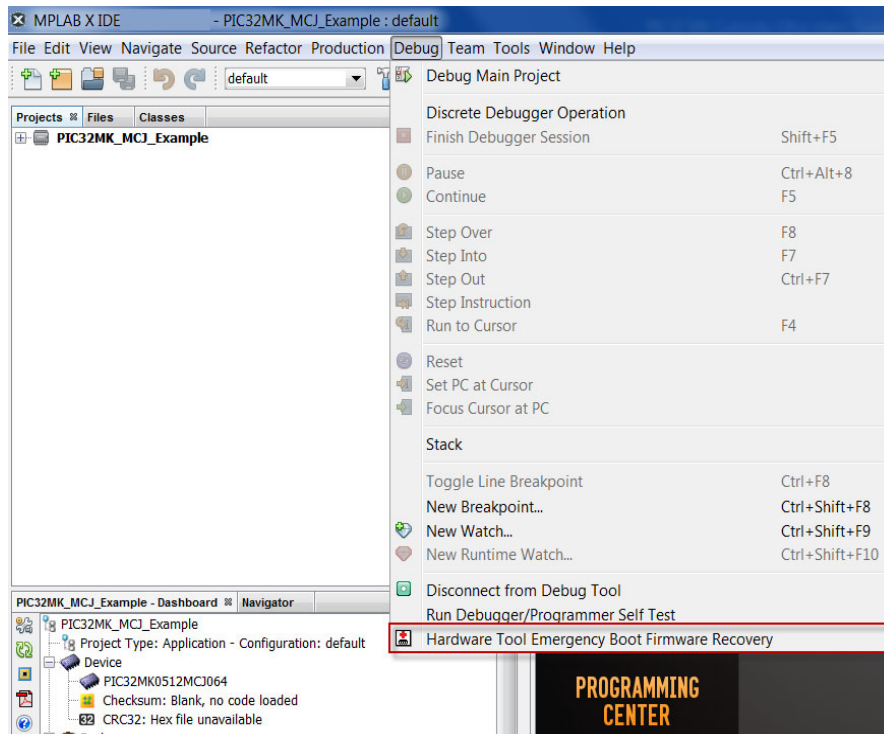

4. Follow the instructions on the screen to reset the tool to factory conditions.

For additional information on PKoB4, refer to the “**MPLAB® PICKit™ 4 User’s Guide**”(DS50002751), which is available for download at the following location: <http://ww1.microchip.com/downloads/en/DeviceDoc/MPLAB%20PICKit%20%20ICD%20Users%20Guide%20DS50002751C.pdf>

## 2.11 Demonstration Firmware Application

The demonstration firmware application comes programmed on the Curiosity Pro board. The project is also available in the downloadable version. Some simple functions of the board are available to exercise in the programmed version. Additional functional source code examples are included in the downloadable version that can be commented in and out of the project.

Connect to the VCP using a terminal app, such as Tera Term with the following settings:

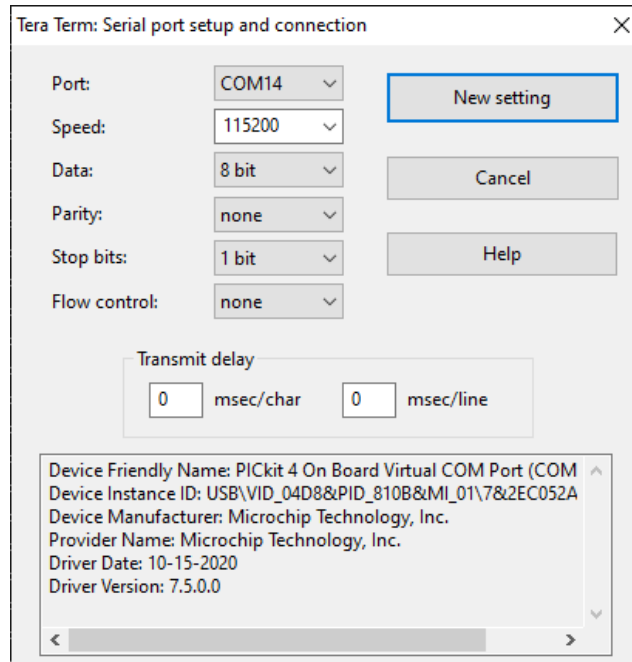

Once connected to the terminal application, a list of available commands can be listed by typing `help<enter>`:

```

COM14 - Tera Term VT
File Edit Setup Control Window KanjiCode Help
>
>help
----- Supported command groups -----
***
Command Table:
(1) led x - Test the LED          x=0 - off
      x=1 - on file
      x=2/3/4/5 - flash
(2) tmp - Reads the temperature sensor
(3) f x - File operation
      x=0 - Write file
      x=1 - Read file
(4) v - Read app version
(5) t x - Time operations
      x=0 - Get time
      x=1 - Set time example- t 1 09:27:00
      x=2 - Set date example- t 2 2021/08/17
(6) gen x - General test functions
      x=0 - Setup test
      x=1 - Run test
      x=2 - Stop test
***
----- Built in commands -----
*** reset: Reset host ***
*** q: quit command processor ***
*** help: help ***
>

```

There are requirements for some of the test functions:

To run the General Test, type `gen 0<enter>` followed by `gen 1<enter>`. The following functions require the General Test to be running to function:

- led commands.
- tmp command.
- f (file operation) command.

When the General Test is running, the analog channels, AN0 and AN1, are read continuously and displayed. When the User button is pushed, an indication of this will appear in the terminal window.

The File Operation commands are available when an SST26 Flash device is attached to the SPI interface on the mikroBUS connector. This can be accomplished using the MIKROE-2267 mikroBUS card or any other mikroBUS card that uses the SST26VF064B SPI Flash device. The file write operation writes a time stamp, and the file read operation reads this back and displays it on the terminal. This can be easily modified to demonstrate a periodic logging task with time stamping.

### **3. Hardware**



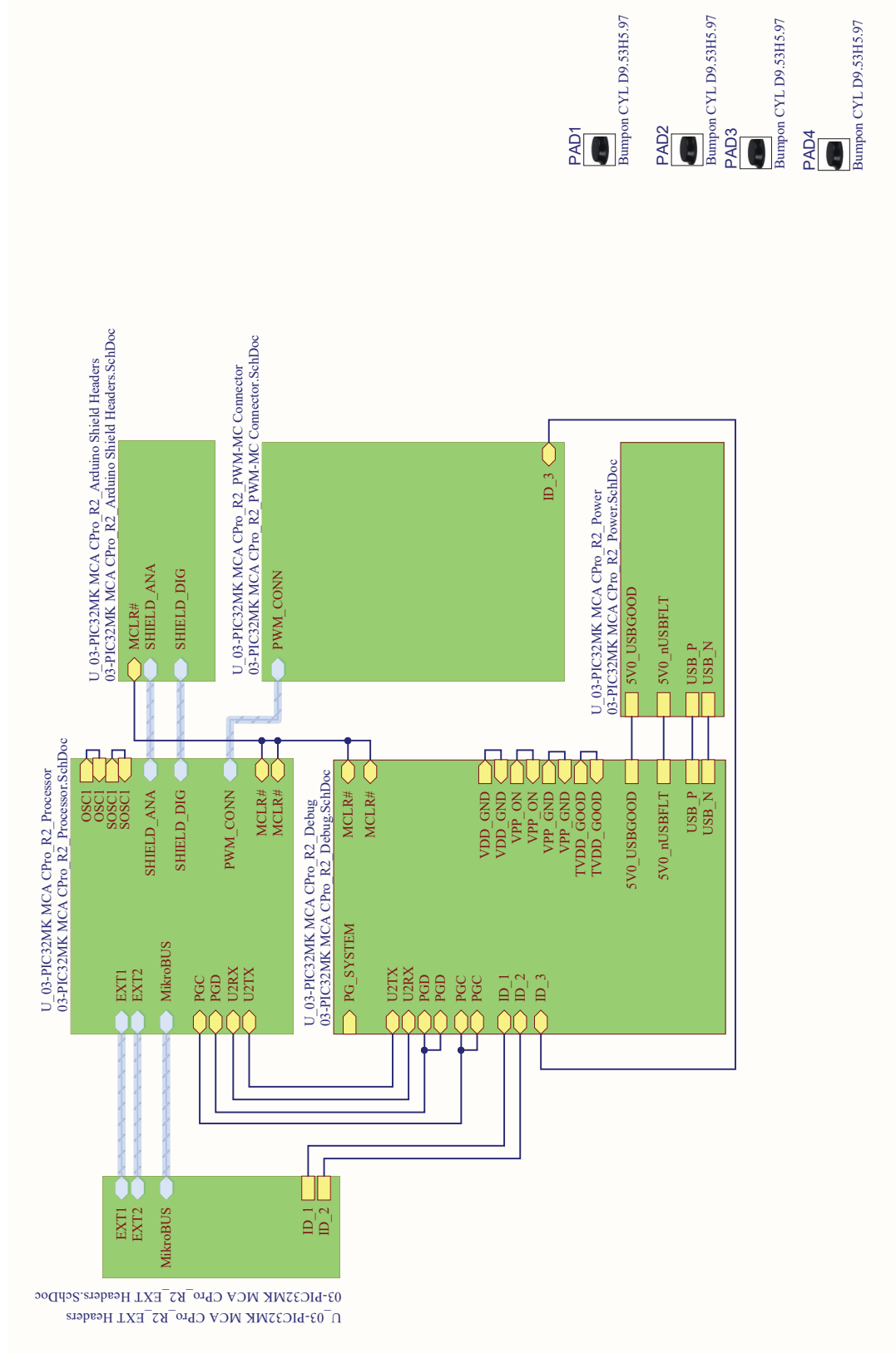

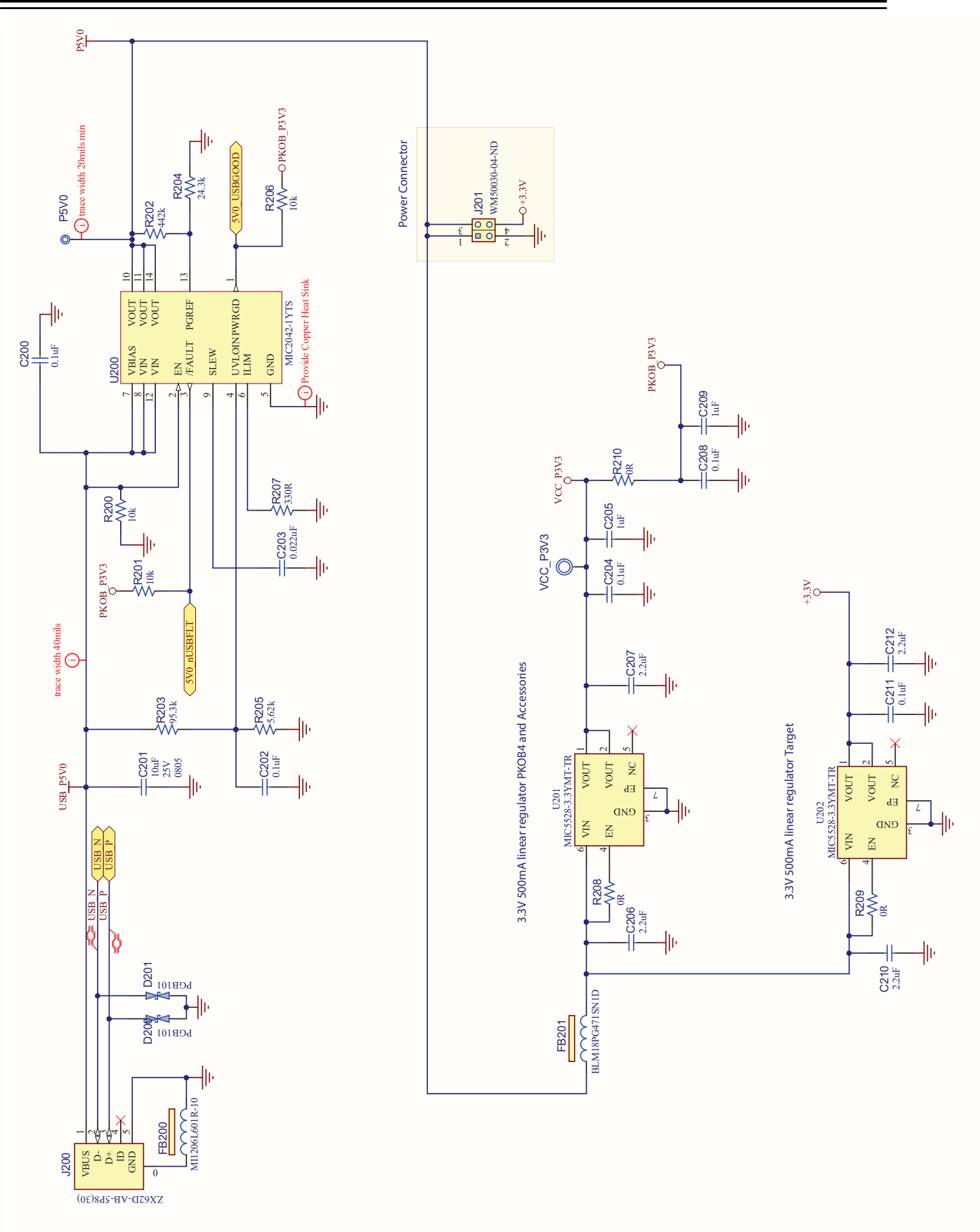



### ARDUINO UNO COMPATIBLE HEADERS

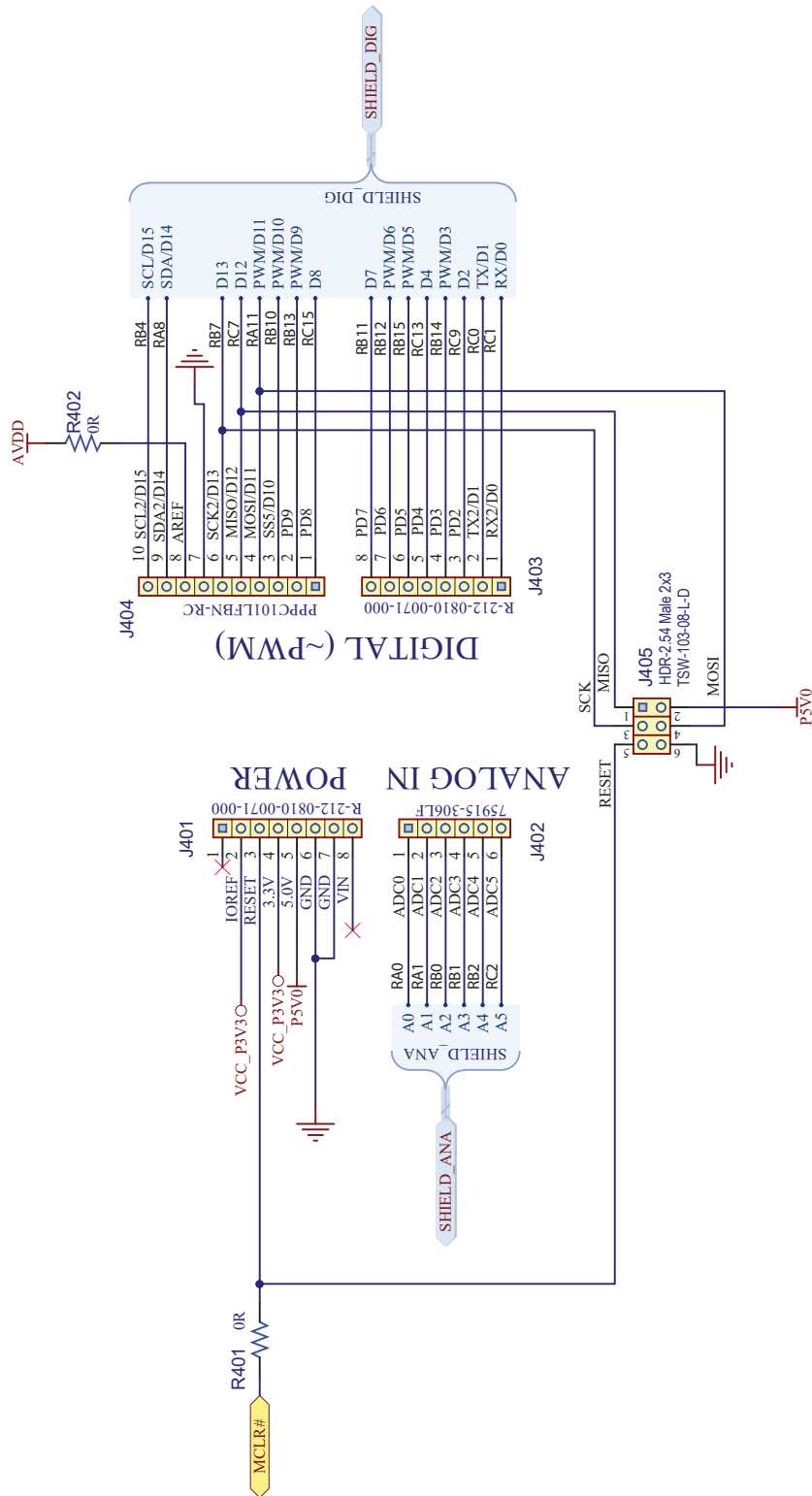

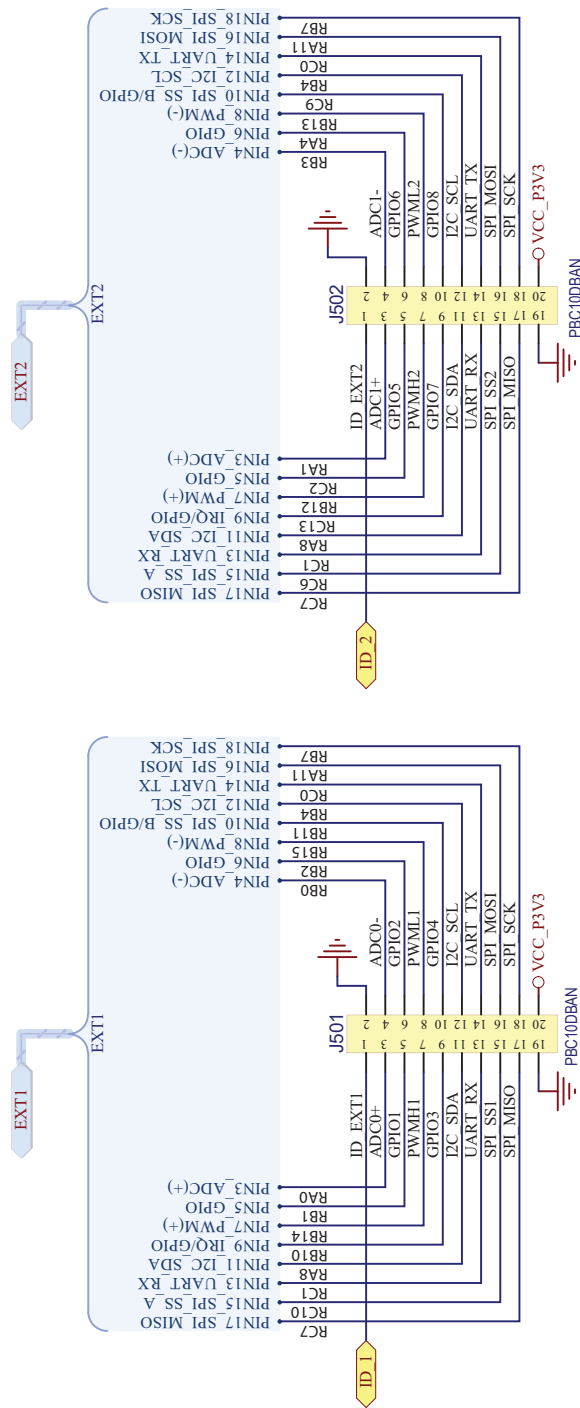





### 3.2 Bill of Materials

Qty	Designator	Description	Manufacturer	Manufacturer Part Number
33	C200, C202, C204, C208, C211, C300, C301, C302, C303, C304, C305, C306, C307, C308, C309, C310, C703, C704, C705, C706, C707, C708, C709, C710, C711, C712, C713, C714, C715, C716, C717, C721, C726	CAP CER 0.1 $\mu$ F 16V 10% X5R SMD 0201	Murata Electronics North America	GRM033R61C104KE84D
3	C201, C722, C723	CAP CER 10 $\mu$ F 25V 10% X5R SMD 0805	TDK Corporation	C2012X5R1E106K125AB
1	C203	CAP CER 0.022 $\mu$ F 16V 10% X7R SMD 0402	Samsung Electro-Mechanics America, Inc	CL05B223K05NNNC
2	C205, C209	CAP CER 1 $\mu$ F 16V 10% X7R SMD 0603	Würth Electronics Inc	885012206052
3	C206, C207, C210	CAP CER 2.2 $\mu$ F 16V 10% X5R SMD 0603	TDK	C1608X5R1C225K
1	C212	CAP CER 2.2 $\mu$ F 16V 10% X7R SMD 0805	Murata	GRM21BR71C225KA12L
2	C724, C725	CAP CER 4.7 $\mu$ F 25V 10% X5R SMD 0805	Murata	GRM21BR61E475KA12L
2	D200, D201	DIO TVS BIDIR PGB101 SMD 0402	Littlefuse	PGB1010402KR
1	D300	DIO LED RED 2V 30mA 2mcd Clear SMD 0603	Lite-On	LTST-C190EKT
2	D301, D702	DIO LED YELLOW 2.1V 20mA 6mcd Clear SMD 0603	Lite-On	LTST-C190YKT
1	D701	DIO LED GREEN 2V 30mA 35mcd Clear SMD 0603	Lite-On Inc	LTST-C191KGKT
2	FB200, FB300	FERRITE 600R@100MHz 2A 80mOhm SMD 1206	Laird-Signal Integrity Products	MI1206L601R-10
1	FB201	FERRITE 470R@100MHz 1A SMD 0603	Murata Electronics North America	BLM18PG471SN1D
1	J200	CON USB2.0 Micro-AB Female ZX62D-AB-5P8(30) TOP MOUNT TH R/A	Hirose Connector	ZX62D-AB-5P8(30)
2	L700, L701	FERRITE 2A 600R SMD 0805	TDK Corporation	MPZ2012S601AT000
1	Q700	TRANS FET P-CH IRLML6402 -20V -3.7A 1.3W SOT-23-3	International Rectifier	IRLML6402TRPBF
3	Q701, Q702, Q703	MCHP ANALOG MOSFET N-CH TN2106 60V 280mA 360mW 2.5R SOT23-3	Microchip Technology	TN2106K1-G
6	R200, R201, R206, R300, R303, R755	RES TKF 10k 1% 1/10W SMD 0402	Panasonic	ERJ-2RKF1002X
1	R202	RES TKF 442k 1% 1/16W SMD 0402	Samsung Electro-Mechanics America, Inc	RC1005F4423CS
1	R203	RES TKF 95.3k 1% 1/16W SMD 0402	Rohm Semiconductor	MCR01MRTF9532
1	R204	RES TKF 24.3k 1% 1/16W SMD 0402	Samsung	RC1005F2432CS
2	R205, R717	RES TKF 5.62k 1% 1/16W SMD 0402	Vishay Dale	CRCW04025K62FKED
10	R207, R302, R307, R720, R721, R722, R723, R736, R737, R747	RES TKF 330R 1% 1/16W SMD 0402	Yageo	RC0402FR-07330RL
7	R208, R209, R210, R308, R401, R402, R753	RES TKF 0R 1/16W SMD 0402	Yageo	RC0402JR-070RL



.....continued

Qty	Designator	Description	Manufacturer	Manufacturer Part Number
1	R301	RES TKF 1k 1% 1/10W SMD 0603	Panasonic	ERJ-3EKF1001V
1	R304	RES TKF 39R 1% 1/16W SMD 0402	Yageo	RC0402FR-0739RL
2	R305, R306	RES TKF 1.8k 1% 1/10W SMD 0402	Panasonic Electronic Components	ERJ-2RKF1801X
2	R709, R715	RES TKF 31.6k 1% 1/10W SMD 0402	Panasonic	ERJ-2RKF3162X
2	R710, R716	RES TKF 47k 5% 1/10W SMD 0402	Panasonic	ERJ-2GEJ473X
9	R711, R712, R726, R728, R735, R738, R739, R740, R741	RES TKF 4.7k 1% 1/16W SMD 0402	Yageo	RC0402FR-074K7L
2	R718, R719	RES TKF 3.3k 5% 1/10W SMD 0402	Panasonic - ECG	ERJ-2GEJ332X
2	R729, R730	RES TKF 22 OHM 1% 1/10W SMD 0603	Yageo	RC0603FR-0722RL
2	R742, R743	RES TKF 100R 5% 1/10W SMD 0603	Vishay	CRCW0603100RJNEA
3	R744, R745, R746	RES TKF 100k 1% 1/10W SMD 0402	Panasonic	ERJ-2RKF1003X
2	SW300, SW301	SWITCH TACT SPST 15V 20mA EVQ-Q2H03W SMD	Panasonic Electronic Components	EVQ-Q2H03W
1	U200	MCHP ANALOG POWER SWITCH 5.5V 3A MIC2042-1YTS TSSOP-14	Microchip Technology	MIC2042-1YTS
2	U201, U202	MCHP ANALOG LDO 3.3V MIC5528-3.3YMT-TR 6-TDFN	Microchip Technology	MIC5528-3.3YMT-TR
1	U300	MCHP ANALOG TEMPERATURE SENSOR -40C to +125C MCP9808T-E/MC DFN-8	Microchip Technology	MCP9808T-E/MC
1	U301	MCHP MCU 32-BIT 120MHz 128kB 32kB PIC32MK0128MCA048-I/Y8X LQFP-48	Microchip Technology	PIC32MK0128MCA048-I/Y8X
1	U700	MCHP MCU 32-BIT 300MHz 2MB 384kB ATSAME70N21B-ANT LQFP-100	Microchip Technology	ATSAME70N21B-ANT
1	U702	MCHP MEMORY SERIAL EEPROM 256k I2C 24LC256-E/ST TSSOP-8	Microchip Technology	24LC256T-E/ST
2	U703, U704	IC TRANSCEIVER 74LVC1T45GW Single Bit Voltage Translator SOT-363	NXP USA Inc.	74LVC1T45GW,125
1	U705	IC SWITCH SPDT 74LVC1G3157 SC-70-6	Texas Instruments	SN74LVC1G3157DCKR
1	Y300	MCHP CLOCK OSCILLATOR SINGLE 12MHz DSC1001DL5-012.0000 SMD-2520	Microchip Technology	DSC1001DL5-012.0000
1	Y301	MCHP CLOCK OSCILLATOR SINGLE 32.768KHz DSC6111JI2B-032K768 VLGA-4	Microchip Technology	DSC6111JI2B-032K768
1	Y700	MCHP CMOS OSCILLATOR 12MHz DSC6011HI1B-012.0000 SMD VFLGA-4	Microchip Technology	DSC6011HI1B-012.0000
1	JP300	MECH HW JUMPER 2.54mm 1x2	3M	969102-0000-DA
4	PAD1, PAD2, PAD3, PAD4	MECH HW RUBBER PAD CYLINDRICAL D9.53H5.97	3M 3M	SJ61A2
1	GND	MISC, TEST POINT MULTI PURPOSE MINI BLACK	Keystone	5001
1	VCC_P3V3	MISC, TEST POINT MULTI PURPOSE MINI RED	Keystone	5000
1	J201	CON HDR-2.54 Male 2x2 Gold 6.75MH TH R/A	Molex	90122-0762
1	J300	CON HDR-2.54 Male 1X2 Gold 6mm MH TH R/A	Würth Electronics Inc.	61300211021

# EV15D86A

## Hardware

.....continued

Qty	Designator	Description	Manufacturer	Manufacturer Part Number
4	J401, J403, J503, J504	CON HDR-2.54 Female 1x8 Tin TH VERT	Sullins	PPTC081LFBN-RC
1	J402	CON HDR-2.54 Female 1x6 Gold TH VERT	FCI	75915-306LF
1	J404	CON HDR-2.54 Female 1x10 Gold TH VERT	Sullins Connector Solutions	PPPC101LFBN-RC
1	J405	CON HDR-2.54 Male 2x3 Gold 5.84MH TH VERT	Samtec	TSW-103-08-L-D
2	J501, J502	CON HDR-2.54 Male 2x10 Rotated 180Degrees Gold TH RT ANGLE	Sullins Connector Solutions	PBC10DBAN
1	J601	CON HDR-2.54 Male 2x15 Gold 5.84MH TH R/A	Samtec Inc.	TSW-115-08-S-D-RA
1	AVDD	MISC, TEST POINT MULTI PURPOSE MINI WHITE	Keystone	5002

## **4. Revision History**

### **Revision B - August 2022**

The following updates were performed in this revision:

- Removed Confidential watermark

### **Revision A - August 2022**

This is the initial released version of this document.

---

## The Microchip Website

---

Microchip provides online support via our website at [www.microchip.com/](http://www.microchip.com/). This website is used to make files and information easily available to customers. Some of the content available includes:

- **Product Support** – Data sheets and errata, application notes and sample programs, design resources, user's guides and hardware support documents, latest software releases and archived software
- **General Technical Support** – Frequently Asked Questions (FAQs), technical support requests, online discussion groups, Microchip design partner program member listing
- **Business of Microchip** – Product selector and ordering guides, latest Microchip press releases, listing of seminars and events, listings of Microchip sales offices, distributors and factory representatives

---

## Product Change Notification Service

---

Microchip's product change notification service helps keep customers current on Microchip products. Subscribers will receive email notification whenever there are changes, updates, revisions or errata related to a specified product family or development tool of interest.

To register, go to [www.microchip.com/pcn](http://www.microchip.com/pcn) and follow the registration instructions.

---

## Customer Support

---

Users of Microchip products can receive assistance through several channels:

- Distributor or Representative
- Local Sales Office
- Embedded Solutions Engineer (ESE)
- Technical Support

Customers should contact their distributor, representative or ESE for support. Local sales offices are also available to help customers. A listing of sales offices and locations is included in this document.

Technical support is available through the website at: [www.microchip.com/support](http://www.microchip.com/support)

---

## Microchip Devices Code Protection Feature

---

Note the following details of the code protection feature on Microchip devices:

- Microchip products meet the specifications contained in their particular Microchip Data Sheet.
- Microchip believes that its family of products is secure when used in the intended manner and under normal conditions.
- There are dishonest and possibly illegal methods being used in attempts to breach the code protection features of the Microchip devices. We believe that these methods require using the Microchip products in a manner outside the operating specifications contained in Microchip's Data Sheets. Attempts to breach these code protection features, most likely, cannot be accomplished without violating Microchip's intellectual property rights.
- Microchip is willing to work with any customer who is concerned about the integrity of its code.
- Neither Microchip nor any other semiconductor manufacturer can guarantee the security of its code. Code protection does not mean that we are guaranteeing the product is "unbreakable." Code protection is constantly evolving. We at Microchip are committed to continuously improving the code protection features of our products. Attempts to break Microchip's code protection feature may be a violation of the Digital Millennium Copyright Act. If such acts allow unauthorized access to your software or other copyrighted work, you may have a right to sue for relief under that Act.

---

## Legal Notice

---

Information contained in this publication is provided for the sole purpose of designing with and using Microchip products. Information regarding device applications and the like is provided only for your convenience and may be superseded by updates. It is your responsibility to ensure that your application meets with your specifications.

THIS INFORMATION IS PROVIDED BY MICROCHIP "AS IS". MICROCHIP MAKES NO REPRESENTATIONS OR WARRANTIES OF ANY KIND WHETHER EXPRESS OR IMPLIED, WRITTEN OR ORAL, STATUTORY OR OTHERWISE, RELATED TO THE INFORMATION INCLUDING BUT NOT LIMITED TO ANY IMPLIED WARRANTIES OF NON-INFRINGEMENT, MERCHANTABILITY, AND FITNESS FOR A PARTICULAR PURPOSE OR WARRANTIES RELATED TO ITS CONDITION, QUALITY, OR PERFORMANCE.

IN NO EVENT WILL MICROCHIP BE LIABLE FOR ANY INDIRECT, SPECIAL, PUNITIVE, INCIDENTAL OR CONSEQUENTIAL LOSS, DAMAGE, COST OR EXPENSE OF ANY KIND WHATSOEVER RELATED TO THE INFORMATION OR ITS USE, HOWEVER CAUSED, EVEN IF MICROCHIP HAS BEEN ADVISED OF THE POSSIBILITY OR THE DAMAGES ARE FORESEEABLE. TO THE FULLEST EXTENT ALLOWED BY LAW, MICROCHIP'S TOTAL LIABILITY ON ALL CLAIMS IN ANY WAY RELATED TO THE INFORMATION OR ITS USE WILL NOT EXCEED THE AMOUNT OF FEES, IF ANY, THAT YOU HAVE PAID DIRECTLY TO MICROCHIP FOR THE INFORMATION. Use of Microchip devices in life support and/or safety applications is entirely at the buyer's risk, and the buyer agrees to defend, indemnify and hold harmless Microchip from any and all damages, claims, suits, or expenses resulting from such use. No licenses are conveyed, implicitly or otherwise, under any Microchip intellectual property rights unless otherwise stated.

---

## Trademarks

---

The Microchip name and logo, the Microchip logo, Adaptec, AnyRate, AVR, AVR logo, AVR Freaks, BesTime, BitCloud, chipKIT, chipKIT logo, CryptoMemory, CryptoRF, dsPIC, FlashFlex, flexPWR, HELDO, IGLOO, JukeBlox, KeeLoq, Klear, LANCheck, LinkMD, maXStylus, maXTouch, MediaLB, megaAVR, Microsemi, Microsemi logo, MOST, MOST logo, MPLAB, OptoLyzer, PackeTime, PIC, picoPower, PICSTART, PIC32 logo, PolarFire, Prochip Designer, QTouch, SAM-BA, SenGenuity, SpyNIC, SST, SST Logo, SuperFlash, Symmetricom, SyncServer, Tachyon, TimeSource, tinyAVR, UNI/O, Vectron, and XMEGA are registered trademarks of Microchip Technology Incorporated in the U.S.A. and other countries.

AgileSwitch, APT, ClockWorks, The Embedded Control Solutions Company, EtherSynch, FlashTec, Hyper Speed Control, HyperLight Load, IntelliMOS, Libero, motorBench, mTouch, Powermite 3, Precision Edge, ProASIC, ProASIC Plus, ProASIC Plus logo, Quiet-Wire, SmartFusion, SyncWorld, Temux, TimeCesium, TimeHub, TimePictra, TimeProvider, WinPath, and ZL are registered trademarks of Microchip Technology Incorporated in the U.S.A.

Adjacent Key Suppression, AKS, Analog-for-the-Digital Age, Any Capacitor, AnyIn, AnyOut, Augmented Switching, BlueSky, BodyCom, CodeGuard, CryptoAuthentication, CryptoAutomotive, CryptoCompanion, CryptoController, dsPICDEM, dsPICDEM.net, Dynamic Average Matching, DAM, ECAN, Espresso T1S, EtherGREEN, IdealBridge, In-Circuit Serial Programming, ICSP, INICnet, Intelligent Paralleling, Inter-Chip Connectivity, JitterBlocker, maxCrypto, maxView, memBrain, Mindi, MiWi, MPASM, MPF, MPLAB Certified logo, MPLIB, MPLINK, MultiTRAK, NetDetach, Omniscient Code Generation, PICDEM, PICDEM.net, PICKit, PICtail, PowerSmart, PureSilicon, QMatrix, REAL ICE, Ripple Blocker, RTAX, RTG4, SAM-ICE, Serial Quad I/O, simpleMAP, SimpliPHY, SmartBuffer, SMART-I.S., storClad, SQL, SuperSwitcher, SuperSwitcher II, Switchtec, SynchroPHY, Total Endurance, TSHARC, USBCheck, VariSense, VectorBlox, VeriPHY, ViewSpan, WiperLock, XpressConnect, and ZENA are trademarks of Microchip Technology Incorporated in the U.S.A. and other countries.

SQTP is a service mark of Microchip Technology Incorporated in the U.S.A.

The Adaptec logo, Frequency on Demand, Silicon Storage Technology, and Symmcom are registered trademarks of Microchip Technology Inc. in other countries.

GestIC is a registered trademark of Microchip Technology Germany II GmbH & Co. KG, a subsidiary of Microchip Technology Inc., in other countries.

All other trademarks mentioned herein are property of their respective companies.

© 2022, Microchip Technology Incorporated, Printed in the U.S.A., All Rights Reserved.

ISBN: 978-1-6683-1056-4

## Quality Management System

---

For information regarding Microchip's Quality Management Systems, please visit [www.microchip.com/quality](http://www.microchip.com/quality).

## Worldwide Sales and Service

AMERICAS	ASIA/PACIFIC	ASIA/PACIFIC	EUROPE
<p><b>Corporate Office</b> 2355 West Chandler Blvd. Chandler, AZ 85224-6199 Tel: 480-792-7200 Tel: 480-792-7277 Technical Support: <a href="http://www.microchip.com/support">www.microchip.com/support</a> Web Address: <a href="http://www.microchip.com">www.microchip.com</a></p> <p><b>Atlanta</b> Duluth, GA Tel: 678-957-9614 Fax: 678-957-1455</p> <p><b>Austin, TX</b> Tel: 512-257-3370</p> <p><b>Boston</b> Westborough, MA Tel: 774-760-0087 Fax: 774-760-0088</p> <p><b>Chicago</b> Itasca, IL Tel: 630-285-0071 Fax: 630-285-0075</p> <p><b>Dallas</b> Addison, TX Tel: 972-818-7423 Fax: 972-818-2924</p> <p><b>Detroit</b> Novi, MI Tel: 248-848-4000</p> <p><b>Houston, TX</b> Tel: 281-894-5983</p> <p><b>Indianapolis</b> Noblesville, IN Tel: 317-773-8323 Fax: 317-773-5453 Tel: 317-536-2380</p> <p><b>Los Angeles</b> Mission Viejo, CA Tel: 949-462-9523 Fax: 949-462-9608 Tel: 951-273-7800</p> <p><b>Raleigh, NC</b> Tel: 919-844-7510</p> <p><b>New York, NY</b> Tel: 631-435-6000</p> <p><b>San Jose, CA</b> Tel: 408-735-9110 Tel: 408-436-4270</p> <p><b>Canada - Toronto</b> Tel: 905-695-1980 Fax: 905-695-2078</p>	<p><b>Australia - Sydney</b> Tel: 61-2-9868-6733</p> <p><b>China - Beijing</b> Tel: 86-10-8569-7000</p> <p><b>China - Chengdu</b> Tel: 86-28-8665-5511</p> <p><b>China - Chongqing</b> Tel: 86-23-8980-9588</p> <p><b>China - Dongguan</b> Tel: 86-769-8702-9880</p> <p><b>China - Guangzhou</b> Tel: 86-20-8755-8029</p> <p><b>China - Hangzhou</b> Tel: 86-571-8792-8115</p> <p><b>China - Hong Kong SAR</b> Tel: 852-2943-5100</p> <p><b>China - Nanjing</b> Tel: 86-25-8473-2460</p> <p><b>China - Qingdao</b> Tel: 86-532-8502-7355</p> <p><b>China - Shanghai</b> Tel: 86-21-3326-8000</p> <p><b>China - Shenyang</b> Tel: 86-24-2334-2829</p> <p><b>China - Shenzhen</b> Tel: 86-755-8864-2200</p> <p><b>China - Suzhou</b> Tel: 86-186-6233-1526</p> <p><b>China - Wuhan</b> Tel: 86-27-5980-5300</p> <p><b>China - Xian</b> Tel: 86-29-8833-7252</p> <p><b>China - Xiamen</b> Tel: 86-592-2388138</p> <p><b>China - Zhuhai</b> Tel: 86-756-3210040</p>	<p><b>India - Bangalore</b> Tel: 91-80-3090-4444</p> <p><b>India - New Delhi</b> Tel: 91-11-4160-8631</p> <p><b>India - Pune</b> Tel: 91-20-4121-0141</p> <p><b>Japan - Osaka</b> Tel: 81-6-6152-7160</p> <p><b>Japan - Tokyo</b> Tel: 81-3-6880-3770</p> <p><b>Korea - Daegu</b> Tel: 82-53-744-4301</p> <p><b>Korea - Seoul</b> Tel: 82-2-554-7200</p> <p><b>Malaysia - Kuala Lumpur</b> Tel: 60-3-7651-7906</p> <p><b>Malaysia - Penang</b> Tel: 60-4-227-8870</p> <p><b>Philippines - Manila</b> Tel: 63-2-634-9065</p> <p><b>Singapore</b> Tel: 65-6334-8870</p> <p><b>Taiwan - Hsin Chu</b> Tel: 886-3-577-8366</p> <p><b>Taiwan - Kaohsiung</b> Tel: 886-7-213-7830</p> <p><b>Taiwan - Taipei</b> Tel: 886-2-2508-8600</p> <p><b>Thailand - Bangkok</b> Tel: 66-2-694-1351</p> <p><b>Vietnam - Ho Chi Minh</b> Tel: 84-28-5448-2100</p>	<p><b>Austria - Wels</b> Tel: 43-7242-2244-39 Fax: 43-7242-2244-393</p> <p><b>Denmark - Copenhagen</b> Tel: 45-4485-5910 Fax: 45-4485-2829</p> <p><b>Finland - Espoo</b> Tel: 358-9-4520-820</p> <p><b>France - Paris</b> Tel: 33-1-69-53-63-20 Fax: 33-1-69-30-90-79</p> <p><b>Germany - Garching</b> Tel: 49-8931-9700</p> <p><b>Germany - Haan</b> Tel: 49-2129-3766400</p> <p><b>Germany - Heilbronn</b> Tel: 49-7131-72400</p> <p><b>Germany - Karlsruhe</b> Tel: 49-721-625370</p> <p><b>Germany - Munich</b> Tel: 49-89-627-144-0 Fax: 49-89-627-144-44</p> <p><b>Germany - Rosenheim</b> Tel: 49-8031-354-560</p> <p><b>Israel - Ra'anana</b> Tel: 972-9-744-7705</p> <p><b>Italy - Milan</b> Tel: 39-0331-742611 Fax: 39-0331-466781</p> <p><b>Italy - Padova</b> Tel: 39-049-7625286</p> <p><b>Netherlands - Druen</b> Tel: 31-416-690399 Fax: 31-416-690340</p> <p><b>Norway - Trondheim</b> Tel: 47-72884388</p> <p><b>Poland - Warsaw</b> Tel: 48-22-3325737</p> <p><b>Romania - Bucharest</b> Tel: 40-21-407-87-50</p> <p><b>Spain - Madrid</b> Tel: 34-91-708-08-90 Fax: 34-91-708-08-91</p> <p><b>Sweden - Gothenberg</b> Tel: 46-31-704-60-40</p> <p><b>Sweden - Stockholm</b> Tel: 46-8-5090-4654</p> <p><b>UK - Wokingham</b> Tel: 44-118-921-5800 Fax: 44-118-921-5820</p>