

Electromechanical Audible Signal Devices / AC Installation Buzzers 338  
**Buzzer EM Contin. tone 230VAC**

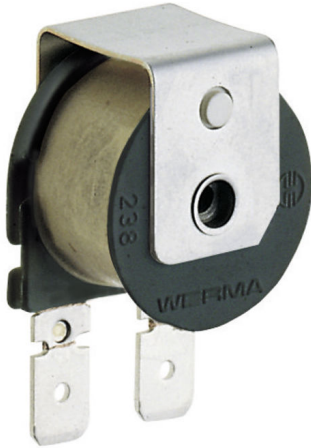

**Part No.:** 338.373.28

#### MECHANICAL DATA

Length	34 mm
Width	23 mm
Height	19 mm
Diameter	23 mm
Materials	PA-GF
Housing colour	Black
Protection category	IP00
Connection	Flat plug
Type of fixing	Built-in mounting
Working temperature minimum	-20°C
Working temperature maximum	+60°C
Weight with packaging	26 g
Product weight	26 g

#### ELECTRICAL DATA

Operating voltage	230V
Operating voltage type	AC
Operating voltage frequency	50Hz
Operating voltage tolerance	+/- 10%
Rated operational voltage	230 VAC
Rated operational current	24 mA
Rated inrush current	<500mA
Pollution degree	2

#### ACOUSTIC DATA

Volume (max) at 1m distance	75,0 dB (A)
Acoustic signal image	Continuous tone
Audio frequency	100 Hz
Acoustic service life	300 h minimum

#### APPROVAL DATA

Conforms with CE	No
WEEE	Yes
Conforms with ATEX-directive	No
Conforms with CCC	No
Conforms with UL	No
Conforms with FCC	No
Conforms with IC	No
EAC certificate available	Yes
Conforms with UKCA (Importer)	No



For additional installation and mounting information, refer to the appropriate user guide at [www.werma.com](http://www.werma.com). This printed copy is for information only and is subject to alteration.

Electromechanical Audible Signal Devices / AC Installation Buzzers 338  
**Buzzer EM Contin. tone 230VAC**

Conforms with AS-I	No
ICAO Certification	No
Conforms with DNV	No
Conforms with RoHS CN	No
Conforms with VdS	No

**DRAWING**

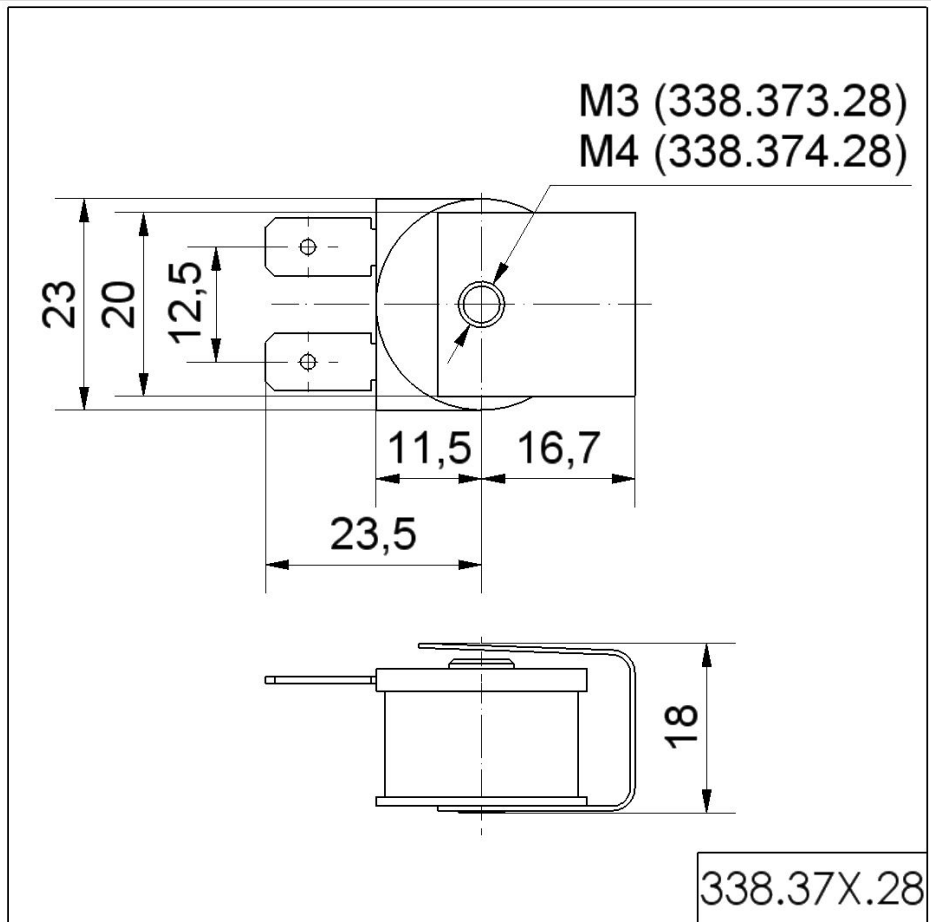

! For additional installation and mounting information, refer to the appropriate user guide at [www.werma.com](http://www.werma.com). This printed copy is for information only and is subject to alteration.