

PRO-SIGNAL



4Kx2K 60Hz HDMI EXTENDER PSG3443

The terms HDMI, HDMI High-Definition Multimedia Interface, and the HDMI Logo are trademarks or registered trademarks of HDMI Licensing Administrator, Inc.

Please read these instructions carefully before use and retain for future reference.

IMPORTANT SAFETY INFORMATION

When using electrical appliances basic safety precautions should always be followed.

- To prevent fire or shock hazard, do not expose this product to rain or moisture.
- Check that the power supply matches the mains voltage.
- Only use the power supply provided or one of identical specification.
- Ensure the IR remote extender cables are connected to the correct devices.
- Beware of static electricity which may damage the device. Use ESD precautions when installing.
- Do not plug or unplug cables while the devices are powered on.

WHAT'S INCLUDED

- HDMI Extender and Receiver
- Power Adapter 230VAC to 5VDC 2A
- Operation Manual
- IR remote extender
- IR remote receiver

FEATURES

- Based on HDbiT technology for a more stable performance.
- Supports full 4K x 2K@60Hz Ultra HD.
- Supports 1 to 1 and 1 to many.
- Transmission up to 120 metres.
- HDMI 2.0 and HDCP 2.2 compliant.

CAT CABLE REQUIREMENT

Follow the standard of IEEE-568B, It is recommended to select a high quality network cable with less loss and crosstalk.

- | | |
|----------------|---------------|
| 1 orange/white | 5 Blue/white |
| 2 orange | 6 Green |
| 3 Green/white | 7 Brown/white |
| 4 Blue | 8 Brown |



OVERVIEW

- This HDMI Extender allows a signal over a CAT5/6 up to 120 metres (150metres on HQ CAT6).
- IR passback with 20-60KHz frequency to control source device.
- Interconnect with other HDbiT VGA/SDI/DVI transmission via CAT5/6.

INSTALLATION

TRANSMITTER

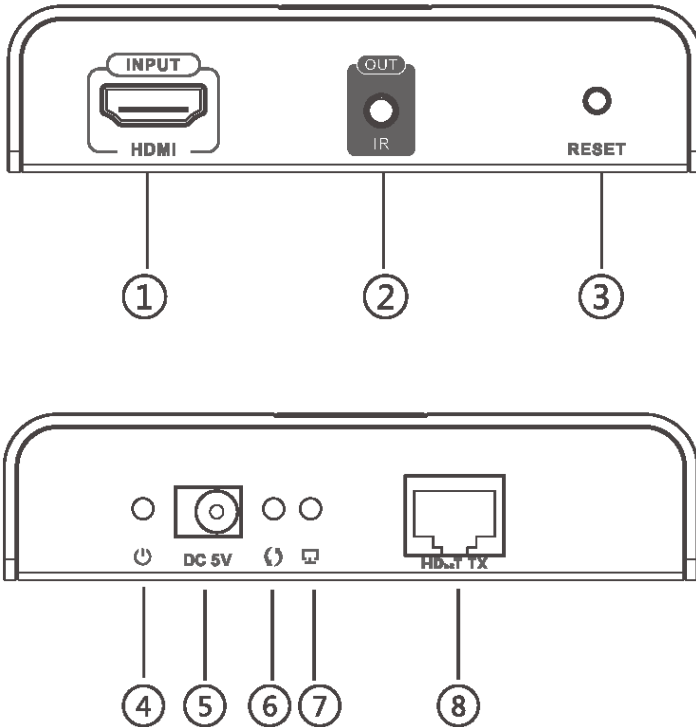

1. HDMI input - connect with source device.
2. IR extender emitter connection
3. Reset button - press to reset the device.
4. Power LED - illuminates when power is on.
5. Power input - connect to PSU 5VDC output jack.
6. Data transmission LED - flashes when transmitting signal.
7. Connection indicator LED - illuminates to indicate connection to receiver is good.
8. CAT network cable RJ45 socket.

RECEIVER

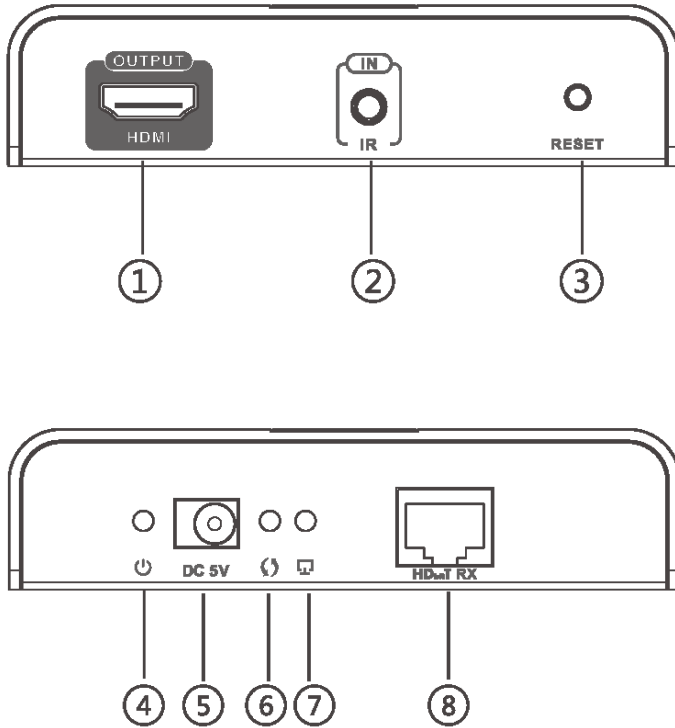

1. HDMI output - connect with destination device.
2. IR extender receiver connection
3. Reset button - press to reset the device.
4. Power LED - illuminates when power is on.
5. Power input - connect to PSU 5VDC output jack.
6. Data transmission LED - flashes when transmitting signal.
7. Connection indicator LED - illuminates to indicate connection to receiver is good.
8. CAT network cable RJ45 socket.

OPERATION

IR User Guide:

- IR receiver extension cable should be connected to the IR IN port of the receiver.
- The IR emitter extension cable should be connected to the IR OUT port of the transmitter.
- The emitter of the IR extension cable should face as close as possible to the IR receiving window of the source device.
- Face the receiving head of the IR receiver extension cable toward the user for unobstructed line of sight to the remote control.
- The IR receiver detects the users remote control and transmits the signal down the network cable to the IR emitter which replicates the IR output to control the source device.

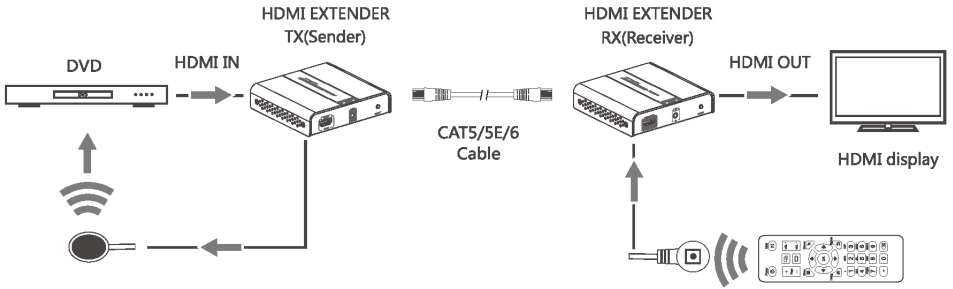

- One to one connection with IR remote up to 150 metres over HQ CAT6 cable.

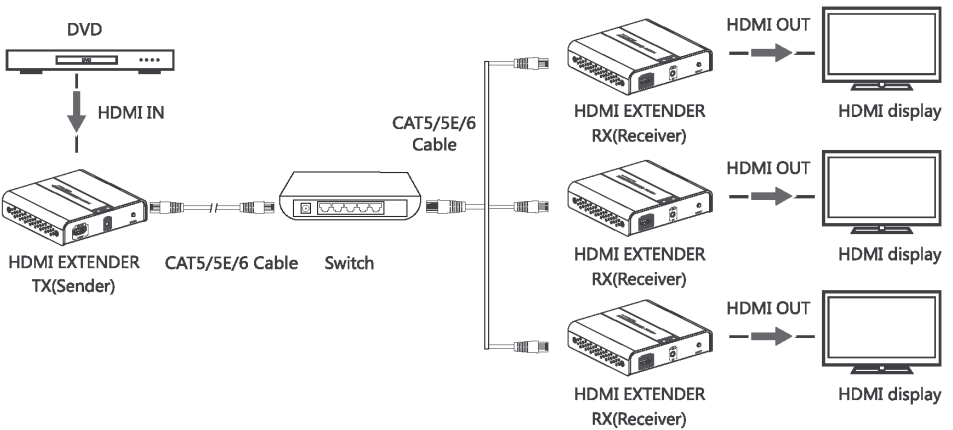

- One to many connection using router/switch over HQ CAT6 cable.

SPECIFICATIONS

| | |
|---------------------------|--|
| Voltage/Current | DC 5V 2A |
| Power consumption | TX: <8W RX: <10W |
| HDMI compliance | HDMI 2.0 |
| HDCP compliance | HDCP 2.2 |
| HDMI input resolution | 480i@60Hz, 480p@60Hz, 576i@50Hz, 576i@50Hz, 576p@50Hz, 720p@50/60Hz, 1080i@50/60Hz, 1080p@50/60Hz, 4Kx2K@24/25/30/60Hz |
| HDMI output resolution | 1080p@60Hz, 4Kx2K@30/60Hz |
| Audio formats | L & R Stereo Audio |
| Max transfer rate | 18Gbps |
| Input/output TMDS signal | 0.7~1.5Vp-p (TDMS) |
| Input/output DDC signal | 5Vp-p (TTL) |
| Transmission length | CAT5 80m / CAT5E 100m / CAT6 120m |
| Input/output cable length | <5m (AWG24) |
| IR remote control | Supports IR passback with 20-60KHz frequency |
| Transfer method | Over UTP/STP CAT5/5e/6 delay <200ms |
| Connector | RJ45 |
| Working temperature | 0~50°C |
| Storage temperature | -10~ 70°C |
| Humidity | 0~90%RH (no condensation) |
| Dimension (RX & TX) | 103(W) x 97.5(D) x 24.8(H)mm |
| Material | Alloy |
| Weight | 420g total |

CLEANING & MAINTENANCE

Clean the outside casing with a soft cloth lightly moistened with mild soap and water. Never use any abrasive or solvents.

CPC Farnell declares that the radio equipment for wireless transmitter/receivers is in compliance with Radio Equipment Directive 2014/53/EU



INFORMATION ON WASTE DISPOSAL FOR CONSUMERS OF ELECTRICAL & ELECTRONIC EQUIPMENT.

When this product has reached the end of its life it must be treated as Waste Electrical & Electronic Equipment (WEEE). Any WEEE marked products must not be mixed with general household waste, but kept separate for the treatment, recovery and recycling of the materials used. Contact your local authority for details of recycling schemes in your area.

Made in China.
PO Box 13362 Dublin 2
PR2 9PP

Man Rev 1.1