



EVQ4323-D-00A

36V, 3A, Low Quiescent Current, Synchronous Step-Down Converter Evaluation Board, AEC-Q100 Qualified

DESCRIPTION

The EVQ4323-D-00A is an evaluation board for the MPQ4323, a configurable-frequency (350kHz to 2.5MHz), synchronous, step-down switching regulator with integrated internal high-side MOSFETs (HS-FETs) and low-side MOSFETs (LS-FETs).

The MPQ4323 provides 3A of highly efficient output current (I_{OUT}) with peak current mode control. The wide 3.3V to 36V input voltage (V_{IN}) range and 42V load dump tolerance accommodates a variety of step-down applications in automotive input environments. A 1 μ A shutdown mode quiescent current (I_Q) allows the device to be used in battery-powered applications.

High power conversion efficiency across a wide load range is achieved by scaling down the

switching frequency (f_{SW}) under light-load conditions to reduce the switching and gate driving losses.

An open-drain power good (PG) signal indicates that the output is within 94.5% to 105.5% of its nominal voltage.

Frequency foldback helps prevent inductor current runaway during start-up. Thermal shutdown provides reliable, fault-tolerant operation.

A high duty cycle and low-dropout mode are provided for automotive cold-crank conditions.

The EVQ4323-D-00A is fully assembled and tested. The MPQ4323 is available in a QFN-12 (2mmx3mm) package with wettable flanks.

PERFORMANCE SUMMARY

Specifications are at $T_A = 25^\circ\text{C}$, unless otherwise noted.

Parameters	Conditions	Value
Input voltage (V_{IN}) range		3.3V to 36V
Output voltage (V_{OUT})	$V_{IN} = 6\text{V to }36\text{V}$, $I_{OUT} = 0\text{A to }3\text{A}$	$V_{OUT} = 5\text{V}$
Maximum output current (I_{OUT})	$V_{IN} = 3.3\text{V to }36\text{V}$	3A
Typical efficiency	$V_{IN} = 12\text{V}$, $V_{OUT} = 5\text{V}$, $I_{OUT} = 3\text{A}$	90.8%
Peak efficiency	$V_{IN} = 8\text{V}$, $V_{OUT} = 5\text{V}$, $I_{OUT} = 1\text{A}$	94.4%
Switching frequency (f_{SW})		2.2MHz

EVALUATION BOARD



LxWxH (8.3cmx8.3cmx1cm)

Board Number	MPS IC Number
EVQ4323-D-00A	MPQ4323GDE-AEC1

QUICK START GUIDE

The EVQ4323-D-00A evaluation board is easy to set up and use to evaluate the performance of the MPQ4323. For proper measurement equipment set-up, refer to Figure 2 on page 4 and follow the steps below:

1. Preset the power supply (V_{IN}) between 6V and 36V, then turn off the power supply.
2. Set load current between 0A and 3A. Electronic loads represent a negative impedance to the regulator, and setting a current too high triggers hiccup mode.
3. If longer cables are used between the source and the EVB (>0.5m total), place a damping capacitor at the input terminals, especially when $V_{IN} \geq 24V$.
4. Connect the power supply terminals to:
 - a. Positive (+): VEMI
 - b. Negative (-): GND
5. Connect the load terminals to:
 - a. Positive (+): VOUT
 - b. Negative (-): GND
6. After making the connections, turn on the power supply.
7. To use the enable function, apply a digital input to the EN pin. Drive EN above 1.02V to turn the regulator on; drive EN below 0.85V to turn it off. If the enable function is not used, EN can be connected directly to V_{IN} .
8. Connect a resistor between the FREQ and GND pins to set the internal oscillator frequency.
9. The external resistor divider sets the output voltage (V_{OUT}) (see Figure 1).

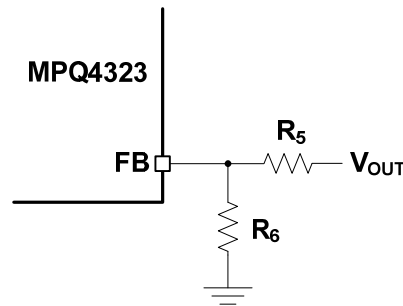

Figure 1: Feedback Divider Network with Adjustable Output

R_5 is selected to be 100k Ω . R_6 can then be calculated using Equation (1):

$$R_6 = \frac{R_5}{\frac{V_{OUT}}{0.8V} - 1} \quad (1)$$

Refer to the Application Information section in the MPQ4323 datasheet to calculate the inductance and output capacitance for different V_{OUT} values.

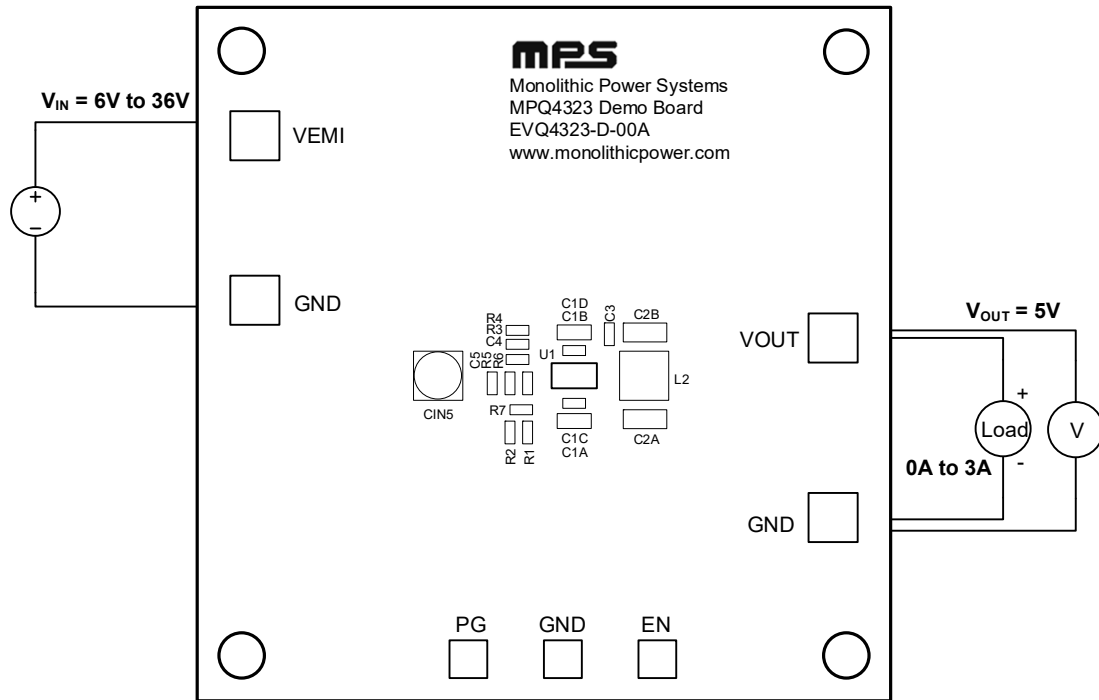

Figure 2: Measurement Equipment Set-Up

EVALUATION BOARD SCHEMATIC

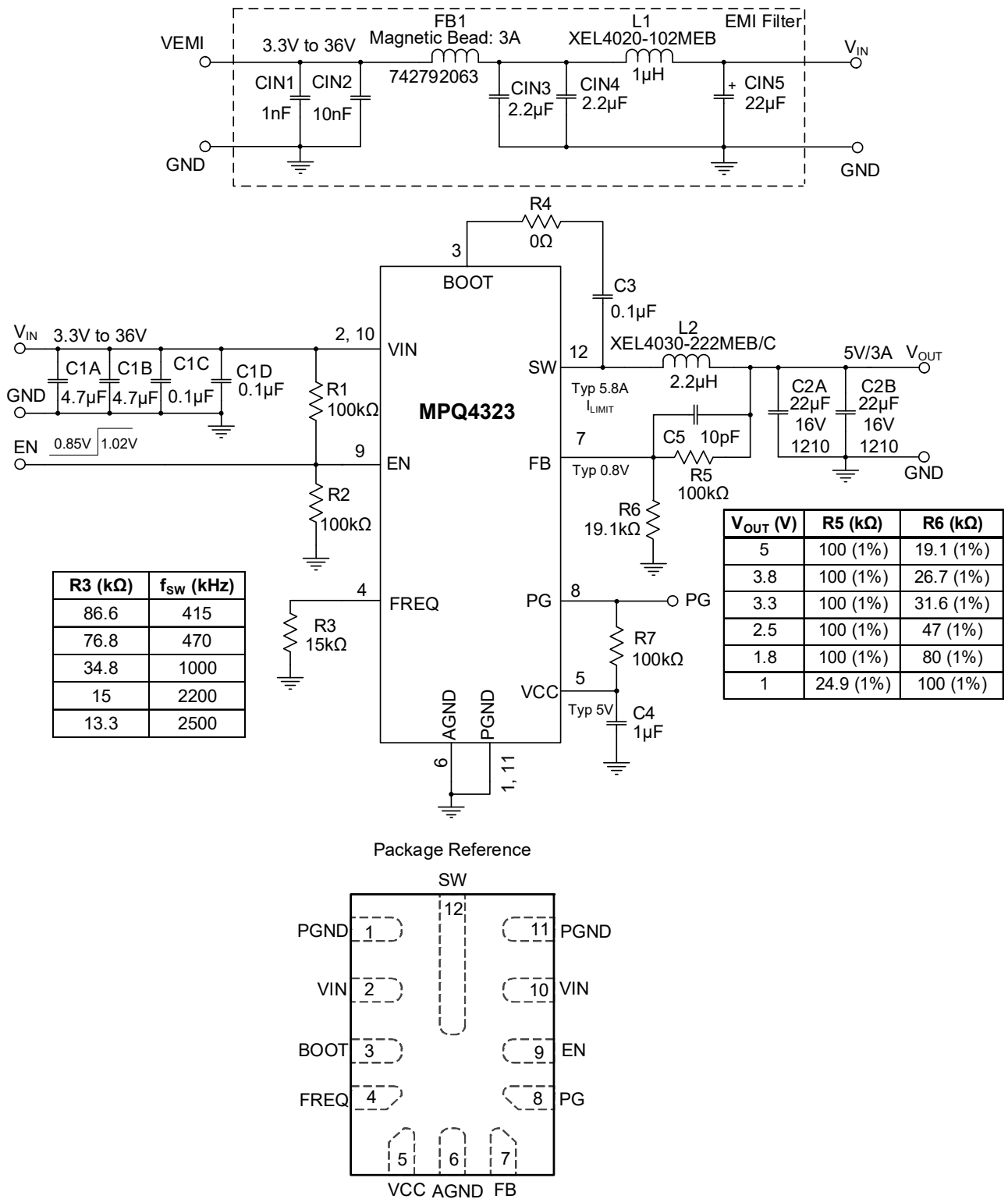

Figure 3: Evaluation Board Schematic

EVQ4323-D-00A BILL OF MATERIALS

Qty	Ref	Value	Description	Package	Manufacturer	Manufacturer PN
1	CIN1	1nF	Ceramic capacitor, 50V, X7R	0603	Murata	GRM216R71H102KA01
1	CIN2	10nF	Ceramic capacitor, 50V, X7R	0603	Murata	GRM188R71H103KA01D
2	CIN3, CIN4	4.7 μ F	Ceramic capacitor, 50V, X7R	0805	Murata	GRM21BR61H475KE51
1	CIN5	22 μ F	Aluminum polymer capacitor, 50V	SMD	Panasonic	EEHZC1H220P
2	C1A, C1B	4.7 μ F	Ceramic capacitor, 50V, X7S	1206	Murata	GRM31CR71H475KA12L
3	C1C, C1D, C3	100nF	Ceramic capacitor, 50V, X7R	0603	Murata	GRM188R71H104KA93D
2	C2A, C2B	22 μ F	Ceramic capacitor, 25V, X7R	1210	Murata	GRM32ER71C226KEA8L
1	C5	10pF	Ceramic capacitor, 50V, NP0	0603	Wurth	885012006051
1	C4	1 μ F	Ceramic capacitor, 25V, X7R	0603	Murata	GCM188R71E105KA64D
1	FB1	3A	Magnetic bead	0805	Wurth	742792063
1	L1	1 μ H	Inductor, 14.6m Ω , 9.6A	SMD	Coilcraft	XEL4020-102MEB
1	L2	2.2 μ H	Inductor, 22.1m Ω , 5.8A	SMD	Coilcraft	XEL4030-222MEB
4	R1, R5, R7, R2	100k Ω	Film resistor, 1%	0603	Yageo	RC0603FR-07100KL
1	R6	19.1k Ω	Film resistor, 1%	0603	Yageo	RC0603FR-0719K1L
1	R3	15k Ω	Film resistor, 1%	0603	Yageo	RC0603FR-0715KL
1	R4	0 Ω	Film resistor, 5%	0603	Yageo	RC0603JR-070RL
1	U1	MPQ4323	3A, low quiescent current, synchronous step-down converter	QFN-12 (2mmx3mm)	MPS	MPQ4323GDE-AEC1

EVB TEST RESULTS

Performance curves and waveforms are tested on the evaluation board, $V_{IN} = 12V$, $V_{OUT} = 5V$, $T_A = 25^\circ C$, unless otherwise noted.

Input Current vs. Load Current

$R_{FB1} = 100k\Omega$, $R_{FB2} = 19.1k\Omega$,
DCR = 22.1m Ω

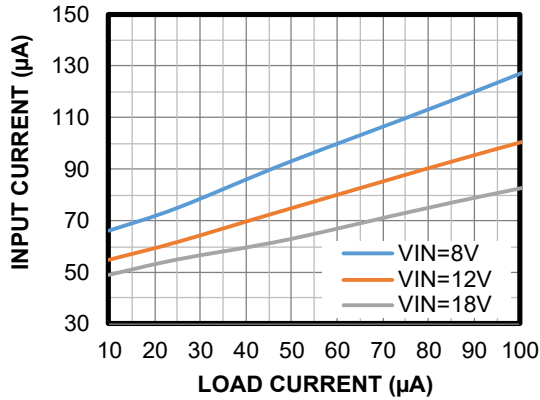

Efficiency vs. Load Current

$R_{FB1} = 100k\Omega$, $R_{FB2} = 19.1k\Omega$,
DCR = 22.1m Ω

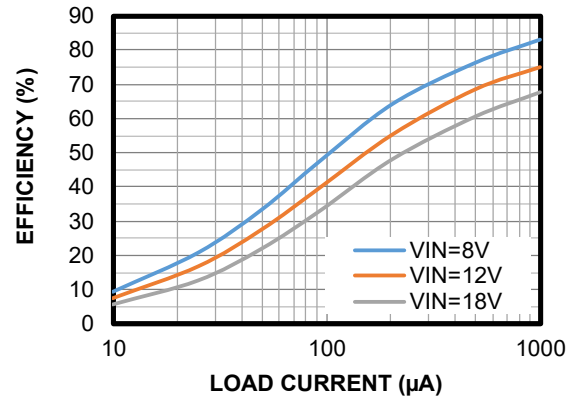

Efficiency vs. Load Current

DCR = 22.1m Ω

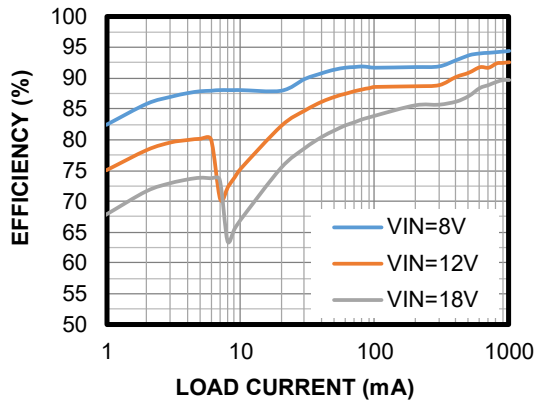

Efficiency vs. Load Current

DCR = 22.1m Ω

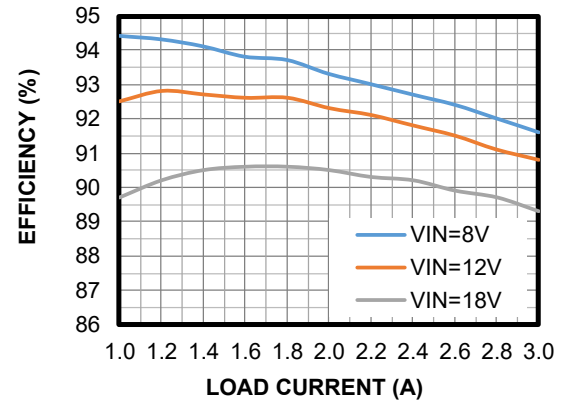

Load Regulation

DCR = 22.1m Ω

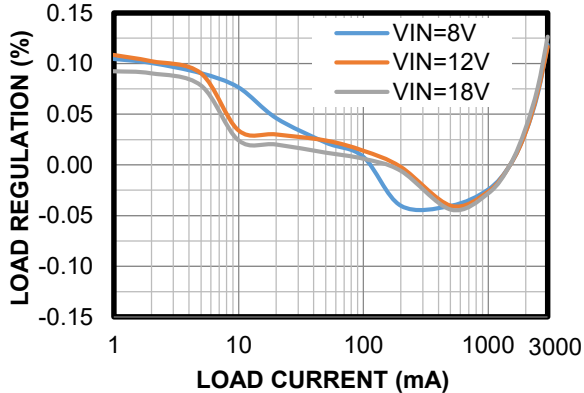

Line Regulation

DCR = 22.1m Ω

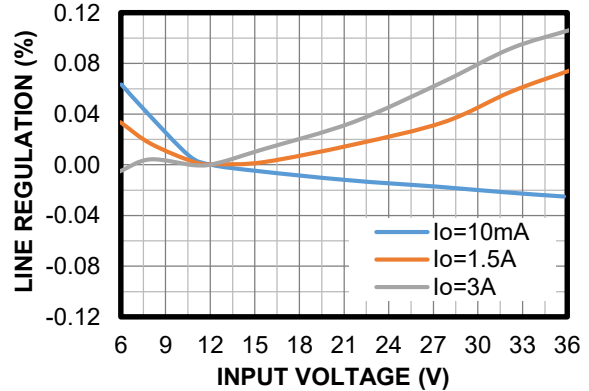

EVb TEST RESULTS (continued)

Performance curves and waveforms are tested on the evaluation board, $V_{IN} = 12V$, $V_{OUT} = 5V$, $T_A = 25^\circ C$, unless otherwise noted.

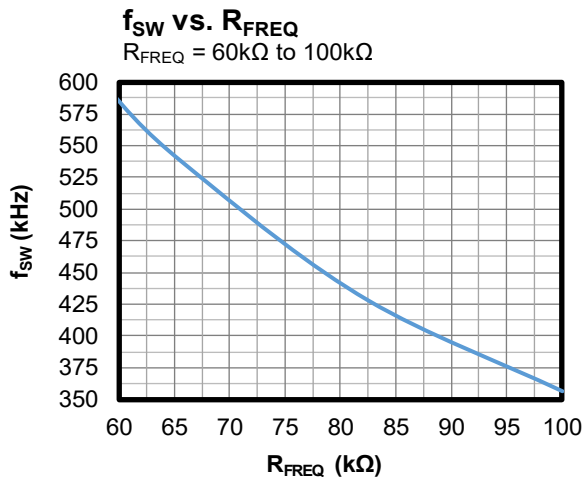
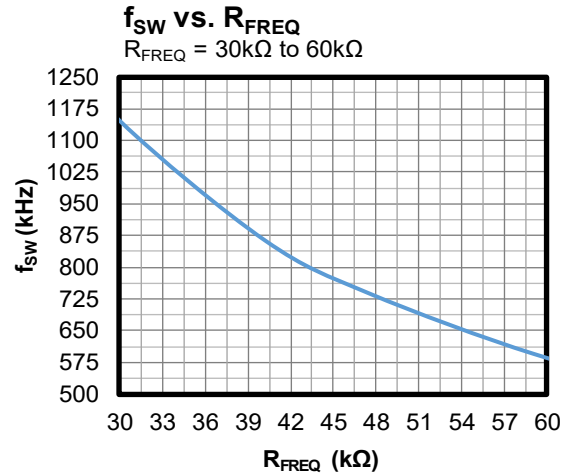
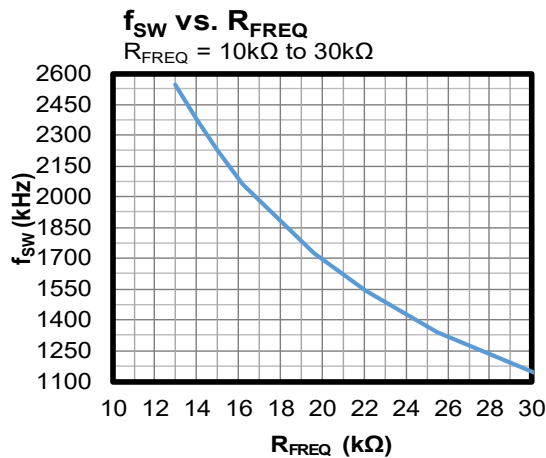
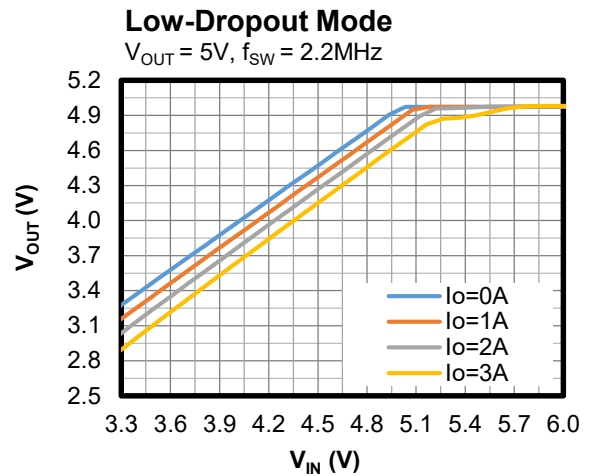
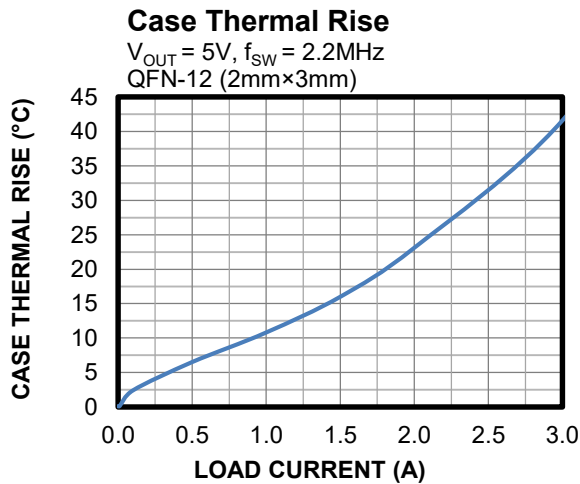

EVB TEST RESULTS (continued)

Performance curves and waveforms are tested on the evaluation board, $V_{IN} = 12V$, $V_{OUT} = 5V$, $T_A = 25^\circ C$, unless otherwise noted.

Thermal Performance

$I_{OUT} = 1.5A$, no forced airflow, $T_{CASE} = 37.1^\circ C$

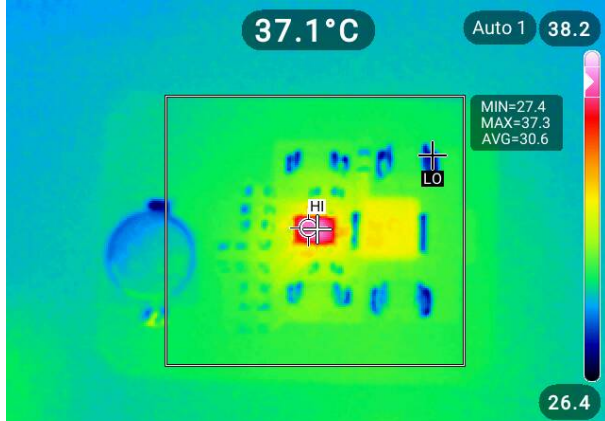

Thermal Performance

$I_{OUT} = 3A$, no forced airflow, $T_{CASE} = 54.5^\circ C$

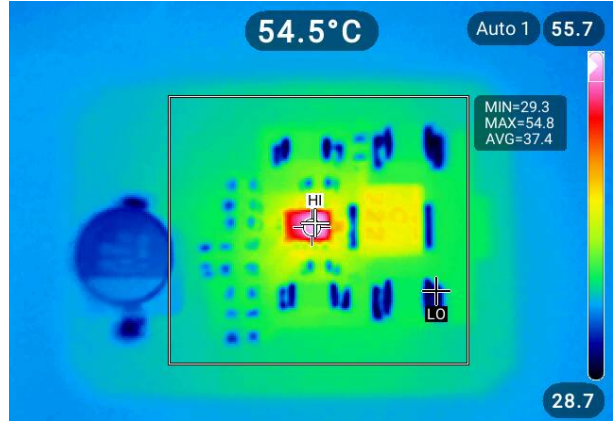

EVB TEST RESULTS (continued)

Performance curves and waveforms are tested on the evaluation board, $V_{IN} = 12V$, $V_{OUT} = 5V$, $T_A = 25^\circ C$, unless otherwise noted.

CISPR25 Class 5 Peak Conducted Emissions

150kHz to 108MHz

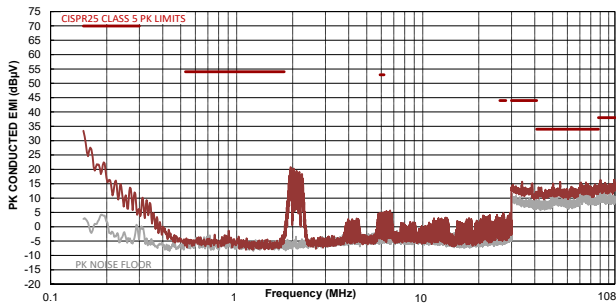

CISPR25 Class 5 Average Conducted Emissions

150kHz to 108MHz

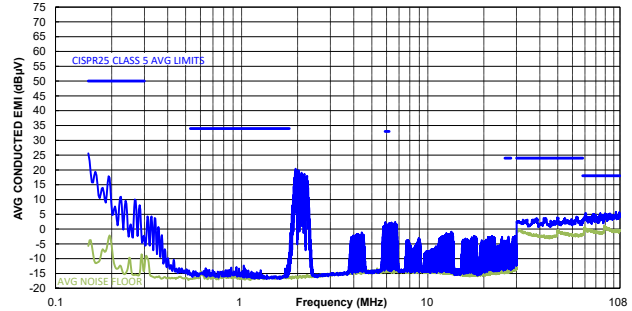

CISPR25 Class 5 Peak Radiated Emissions

150kHz to 30MHz

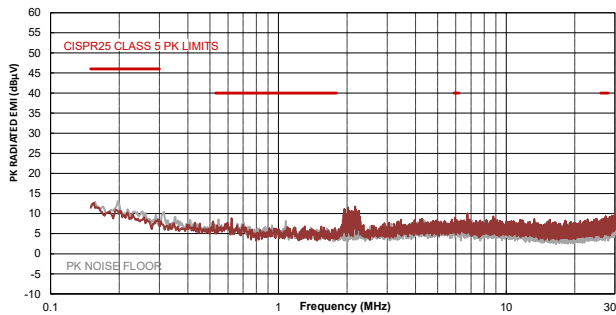

CISPR25 Class 5 Average Radiated Emissions

150kHz to 30MHz

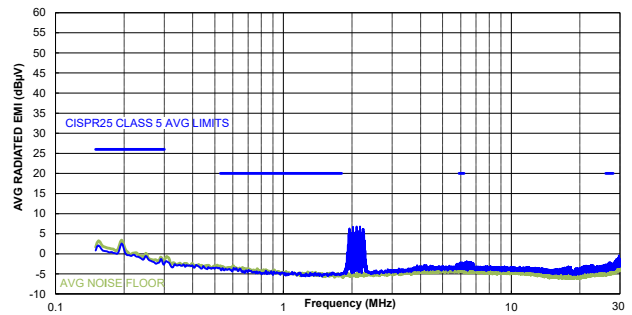

CISPR25 Class 5 Peak Radiated Emissions

Horizontal, 30MHz to 1GHz

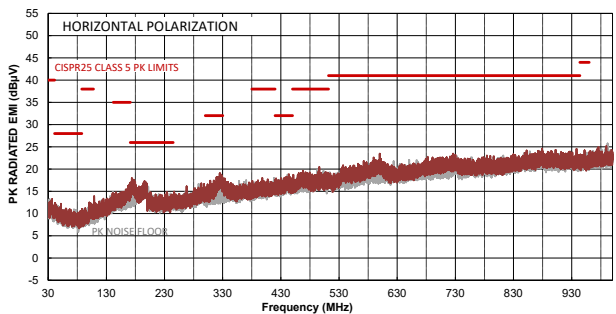

CISPR25 Class 5 Average Radiated Emissions

Horizontal, 30MHz to 1GHz

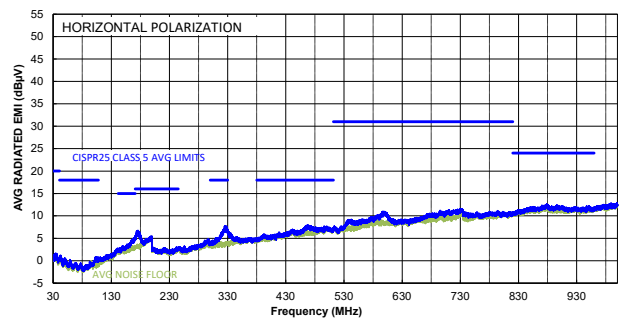

EVB TEST RESULTS (continued)

Performance curves and waveforms are tested on the evaluation board, $V_{IN} = 12V$, $V_{OUT} = 5V$, $T_A = 25^{\circ}C$, unless otherwise noted.

CISPR25 Class 5 Peak Radiated Emissions

Vertical, 30MHz to 1GHz

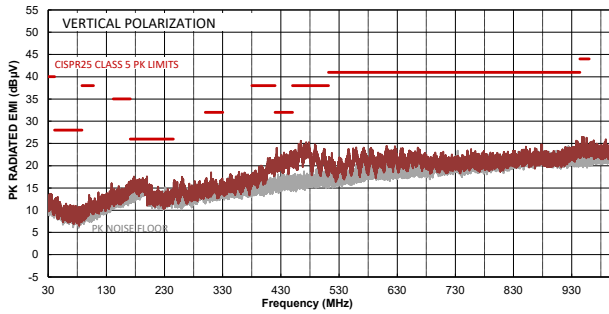

CISPR25 Class 5 Average Radiated Emissions

Vertical, 30MHz to 1GHz

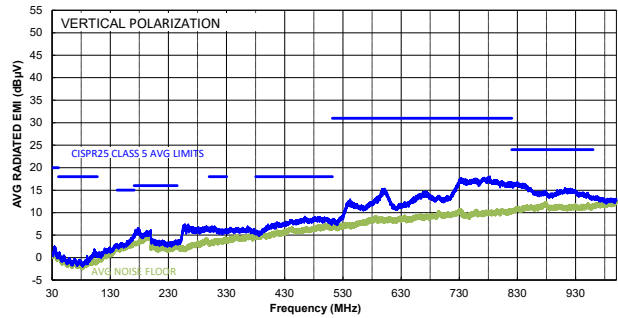

EVB TEST RESULTS (continued)

Performance curves and waveforms are tested on the evaluation board, $V_{IN} = 12V$, $V_{OUT} = 5V$, $T_A = 25^\circ C$, unless otherwise noted.

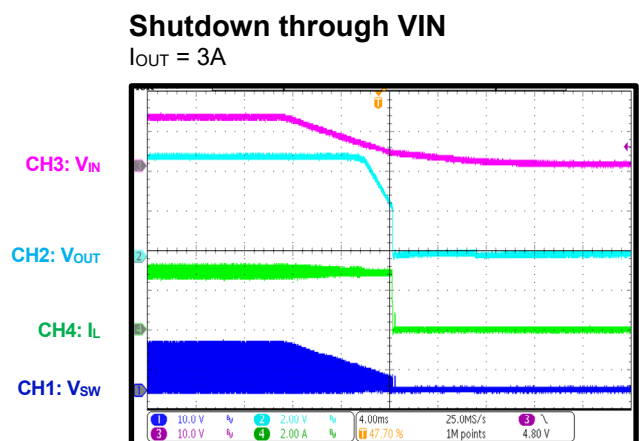
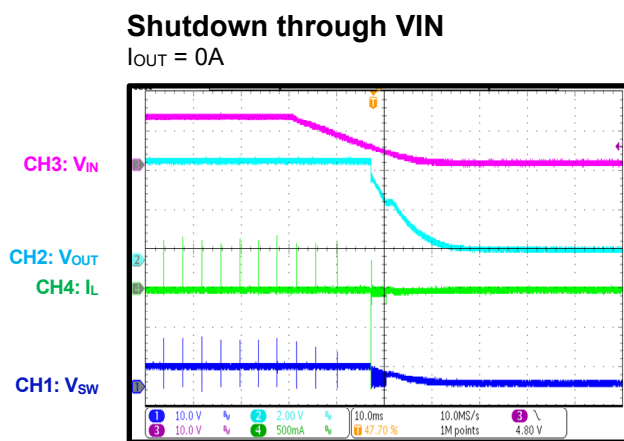
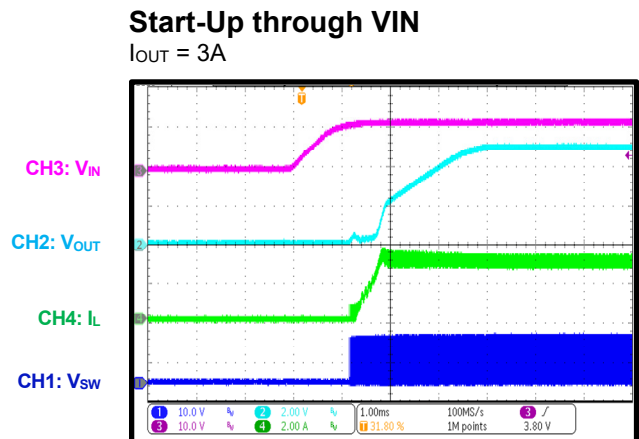
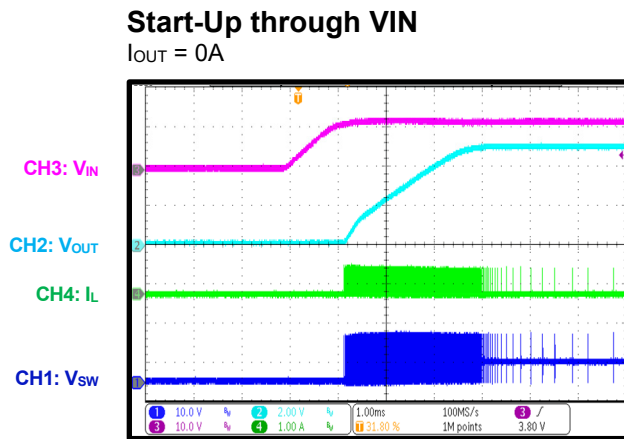
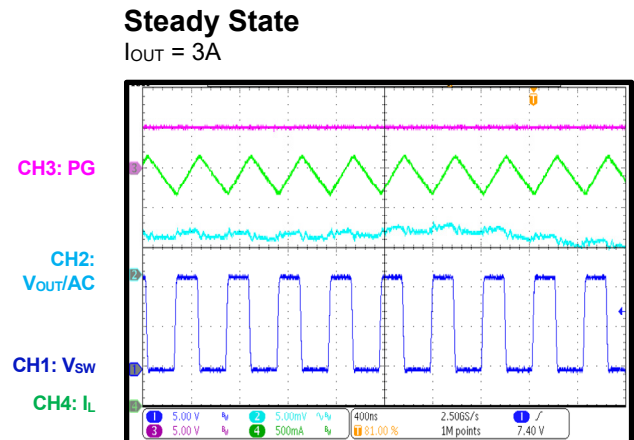
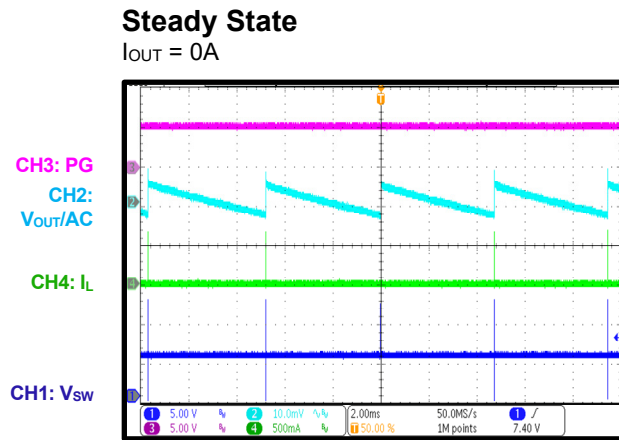

EVB TEST RESULTS (continued)

Performance curves and waveforms are tested on the evaluation board, $V_{IN} = 12V$, $V_{OUT} = 5V$, $T_A = 25^\circ C$, unless otherwise noted.

Start-Up through EN
 $I_{OUT} = 0A$

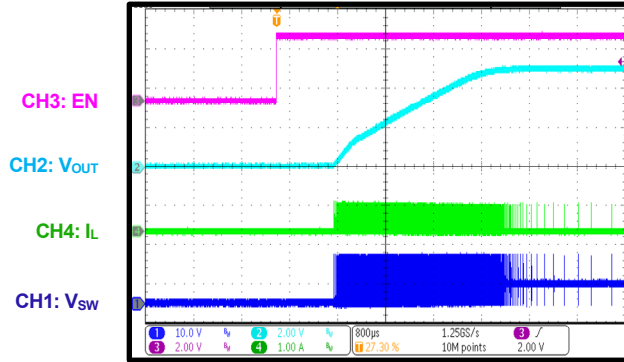

Start-Up through EN
 $I_{OUT} = 3A$

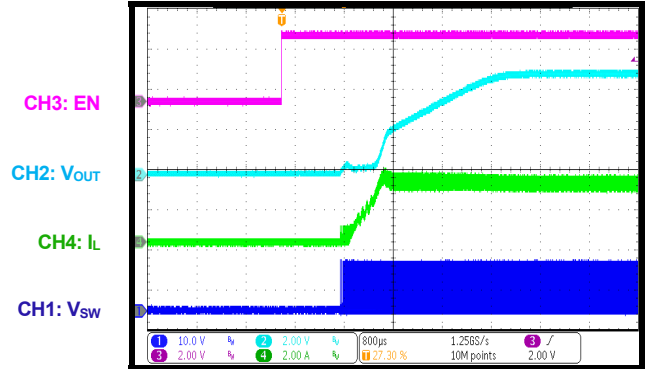

Shutdown through EN
 $I_{OUT} = 0A$

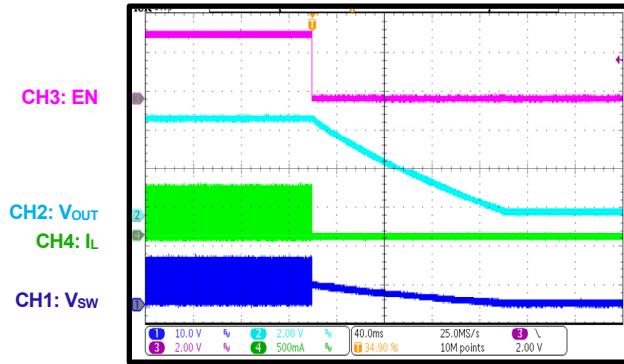

Shutdown through EN
 $I_{OUT} = 3A$

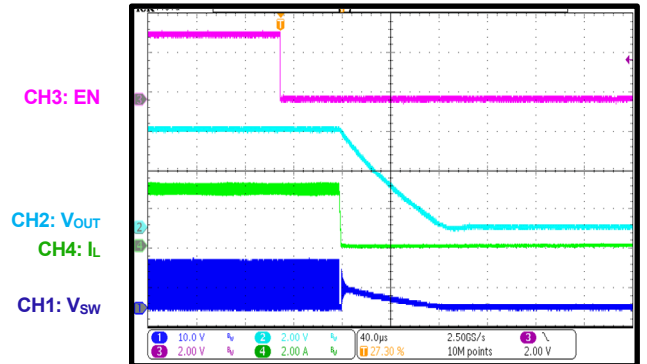

PG in Start-Up through VIN
 $I_{OUT} = 0A$

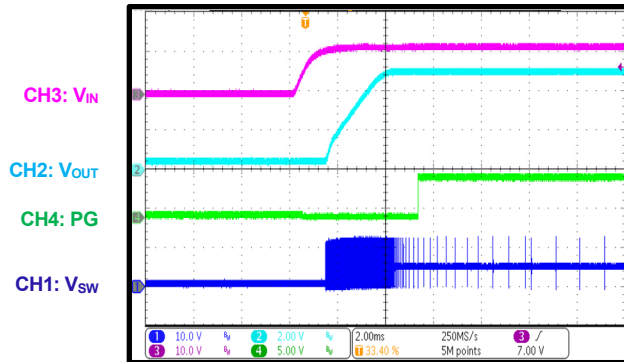

PG in Start-Up through VIN
 $I_{OUT} = 3A$

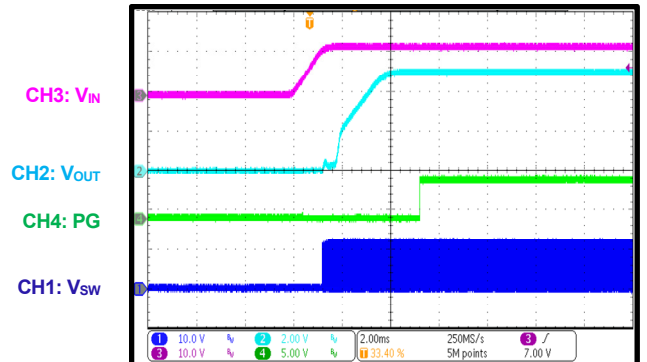

EVB TEST RESULTS (continued)

Performance curves and waveforms are tested on the evaluation board, $V_{IN} = 12V$, $V_{OUT} = 5V$, $T_A = 25^{\circ}C$, unless otherwise noted.

PG in Shutdown through VIN
 $I_{OUT} = 0A$

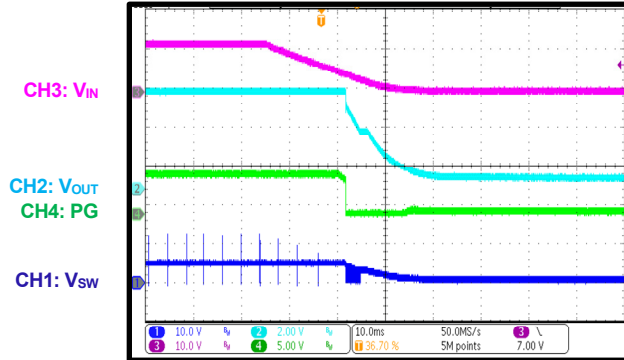

PG in Shutdown through VIN
 $I_{OUT} = 3A$

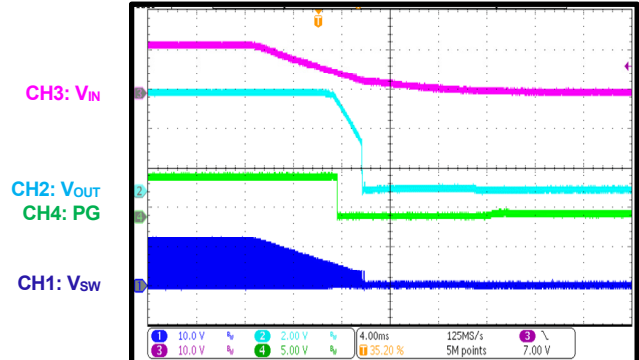

PG in Start-Up through EN
 $I_{OUT} = 0A$

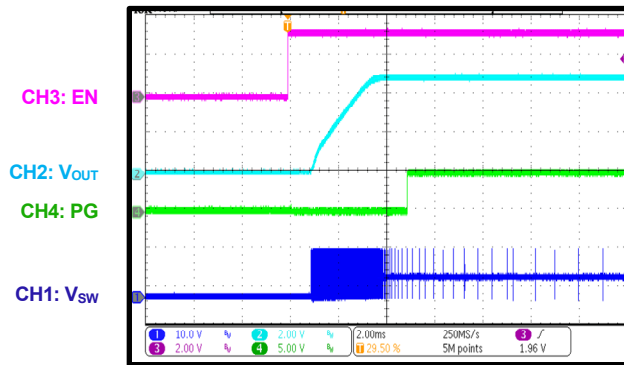

PG in Start-Up through EN
 $I_{OUT} = 3A$

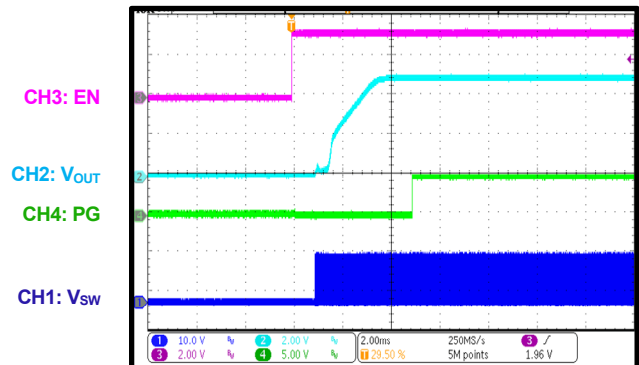

PG in Shutdown through EN
 $I_{OUT} = 0A$

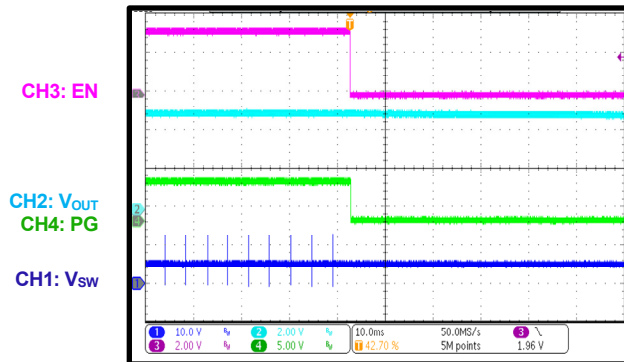

PG in Shutdown through EN
 $I_{OUT} = 3A$

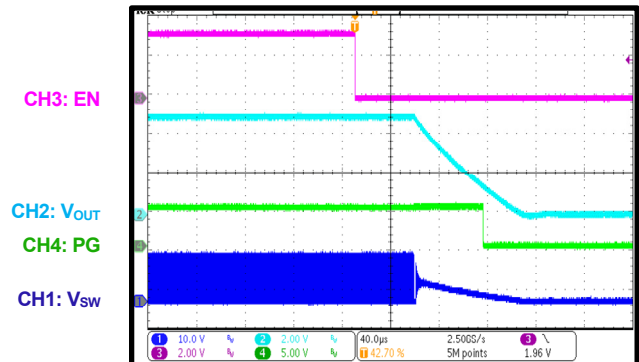

EVB TEST RESULTS (continued)

Performance curves and waveforms are tested on the evaluation board, $V_{IN} = 12V$, $V_{OUT} = 5V$, $T_A = 25^{\circ}C$, unless otherwise noted.

Low-Dropout Mode

$I_{OUT} = 0A$, $V_{IN} = 3.3V$

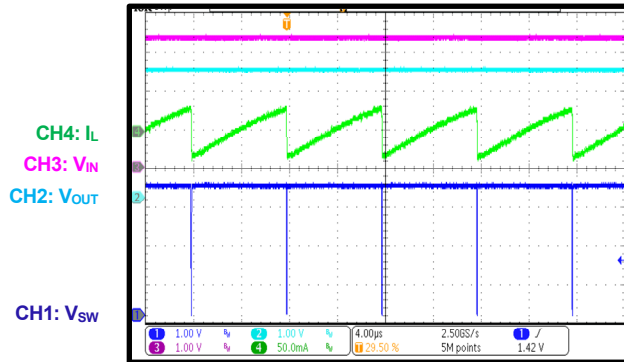

Low-Dropout Mode

$I_{OUT} = 3A$, $V_{IN} = 3.3V$

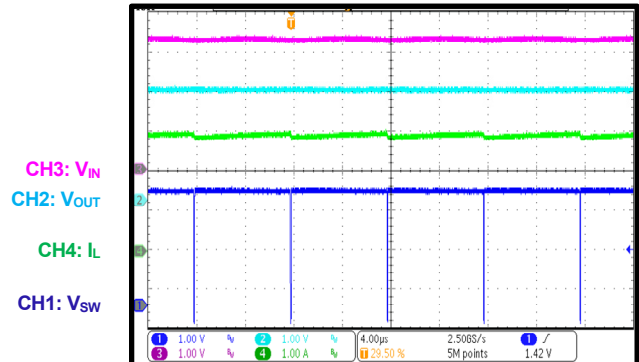

SCP Entry

$I_{OUT} = 0A$

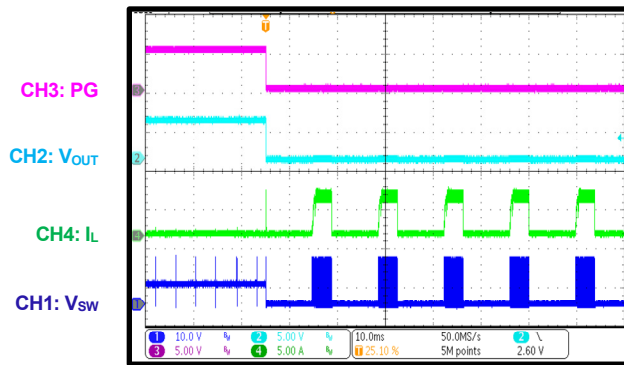

SCP Entry

$I_{OUT} = 3A$

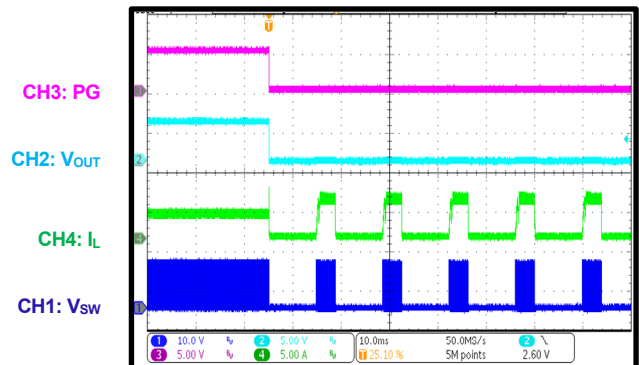

SCP Recovery

$I_{OUT} = 0A$

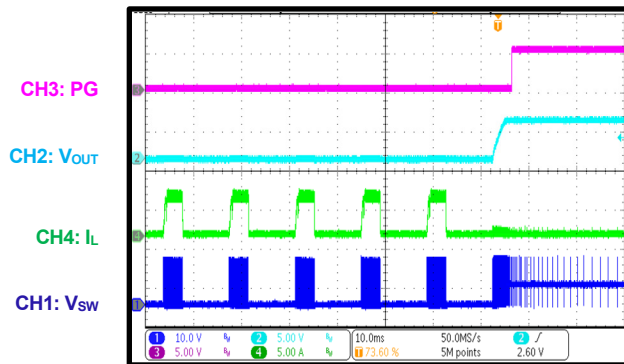

SCP Recovery

$I_{OUT} = 3A$

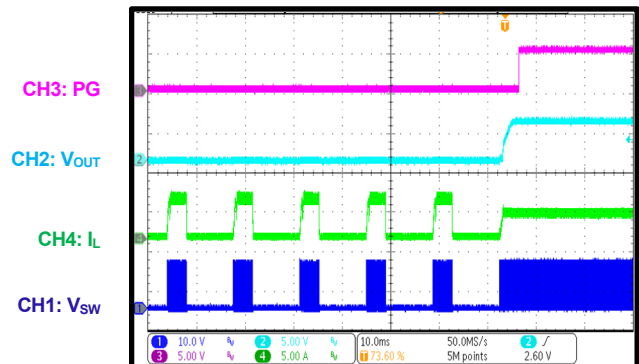

EVB TEST RESULTS (continued)

Performance curves and waveforms are tested on the evaluation board, $V_{IN} = 12V$, $V_{OUT} = 5V$, $T_A = 25^\circ C$, unless otherwise noted.

SCP Steady State

$I_{OUT} = 0A$

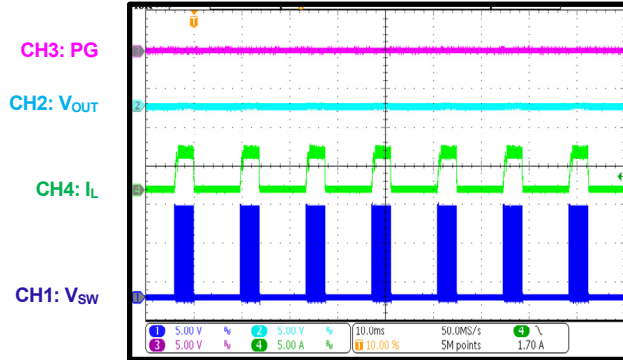

Load Transient

$I_{OUT} = 1.5A$ to $3A$, $1.6A/\mu s$

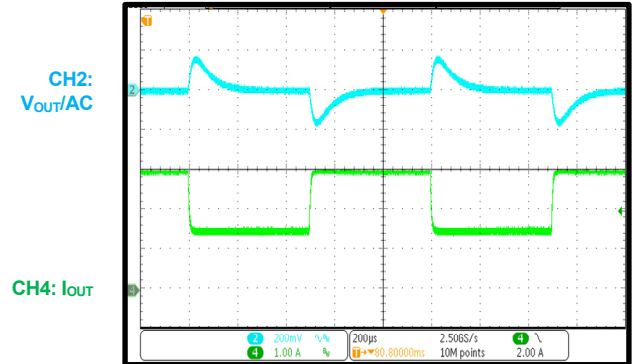

Load Dump

$V_{IN} = 12V$ to $42V$, $I_{OUT} = 0A$

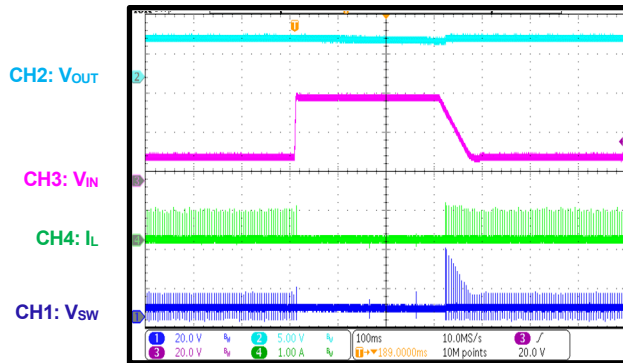

Load Dump

$V_{IN} = 12V$ to $42V$, $I_{OUT} = 3A$

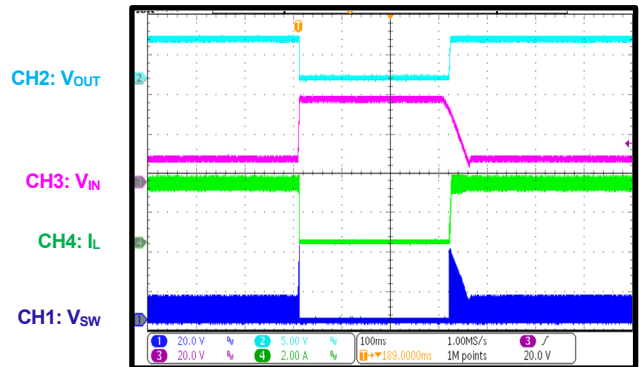

Cold Crank

$V_{IN} = 12V$ to $3.3V$ to $6V$, $I_{OUT} = 0A$

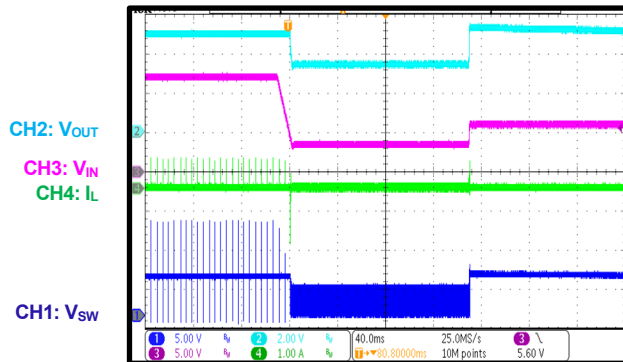

Cold Crank

$V_{IN} = 12V$ to $3.3V$ to $6V$, $I_{OUT} = 3A$

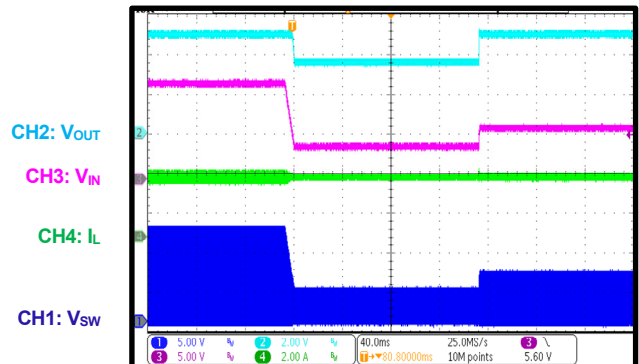

EVB TEST RESULTS *(continued)*

Performance curves and waveforms are tested on the evaluation board. $V_{IN} = 12V$, $V_{OUT} = 5V$, $T_A = 25^{\circ}C$, unless otherwise noted.

V_{IN} Ramping Down and Up
 $V_{IN} = 6V$ to $0V$, $0.5V/min$, $I_{OUT} = 0A$

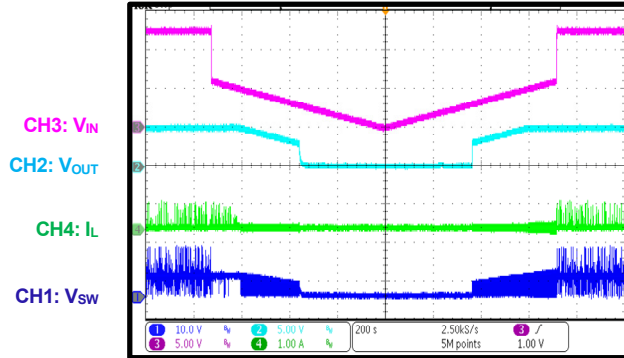

V_{IN} Ramping Down and Up
 $V_{IN} = 6V$ to $0V$, $0.5V/min$, $I_{OUT} = 3A$

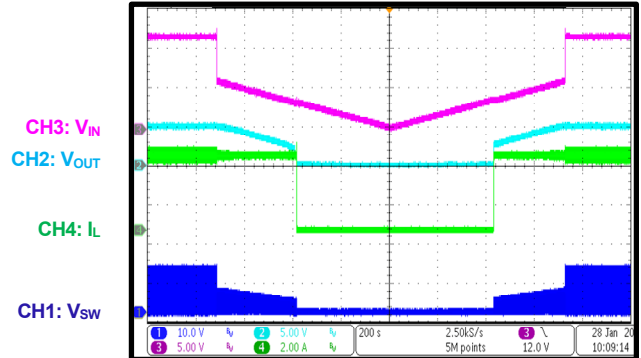

PCB LAYOUT

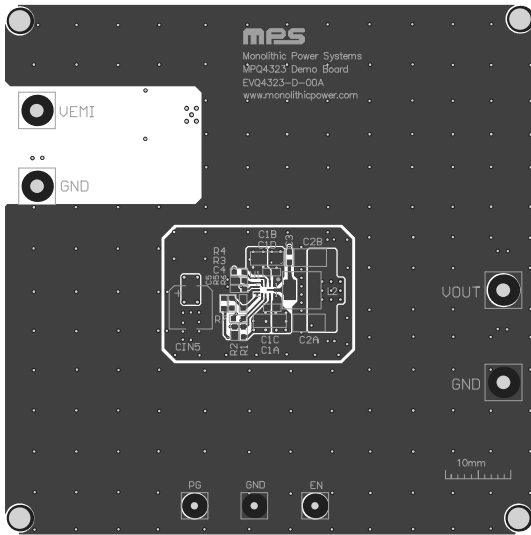

Figure 3: Top Silk and Top Layer

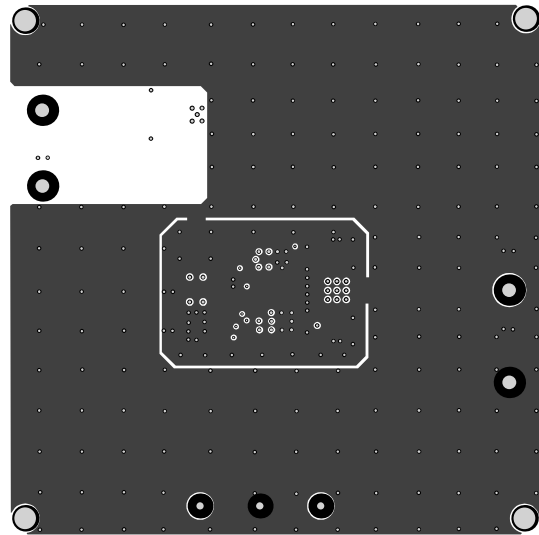

Figure 4: Mid-Layer 1

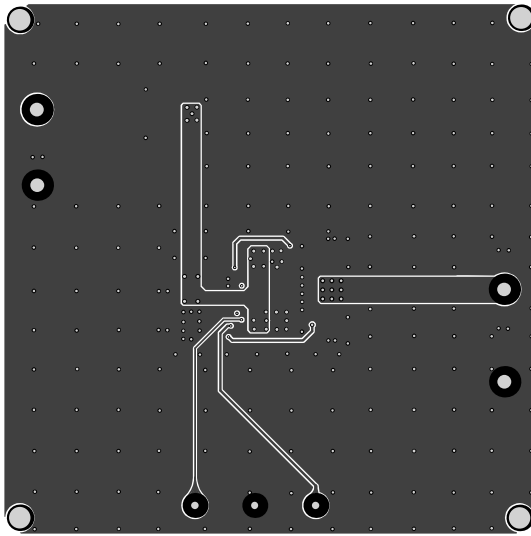

Figure 5: Mid-Layer 2

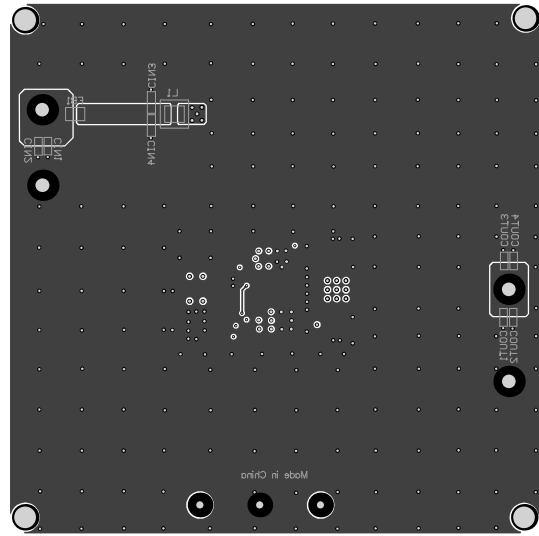

Figure 6: Bottom Layer and Bottom Silk



REVISION HISTORY

Revision #	Revision Date	Description	Pages Updated
1.0	11/16/2021	Initial Release	-

Notice: The information in this document is subject to change without notice. Please contact MPS for current specifications. Users should warrant and guarantee that third-party Intellectual Property rights are not infringed upon when integrating MPS products into any application. MPS will not assume any legal responsibility for any said applications.