

© COPYRIGHT 19 78 BY AMP INCORPORATED, HARRISBURG, PA. ALL INTERNATIONAL RIGHTS RESERVED. AMP INCORPORATED PRODUCTS COVERED BY U. S. AND FOREIGN PATENTS AND/OR PATENTS PENDING.

REVISIONS					
P	F	ZONE	DESCRIPTION	DATE	APPROVED
✓	✓	C	REV PER EC 0730-0201-84	4/25/85	JH RS
✓	✓				
✓	✓				
✓	✓				

- ⚠ SHEET METAL SCREWS NOT SUPPLIED.
 - ⚠ INSERT IS ATTACHED TO STRAIN RELIEF AS AN ADDITIONAL ADJUSTMENT FOR SMALL WIRE BUNDLES, IT SHOULD BE CUT OFF AND POSITIONED AS SHOWN BY DOTTED LINES.
 - ⚠ TWO REQUIRED PER CONNECTOR.
4. DETACHABLE INSERT MAY SEPARATE FROM STRAIN RELIEF BODY DURING SHIPPING.

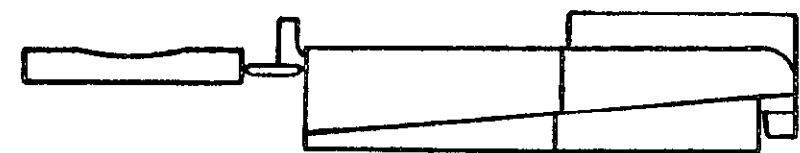

(2 REQ'D) #6 x .375 LG. TYPE "B" PAN HEAD SHEET METAL SCREW ⚠

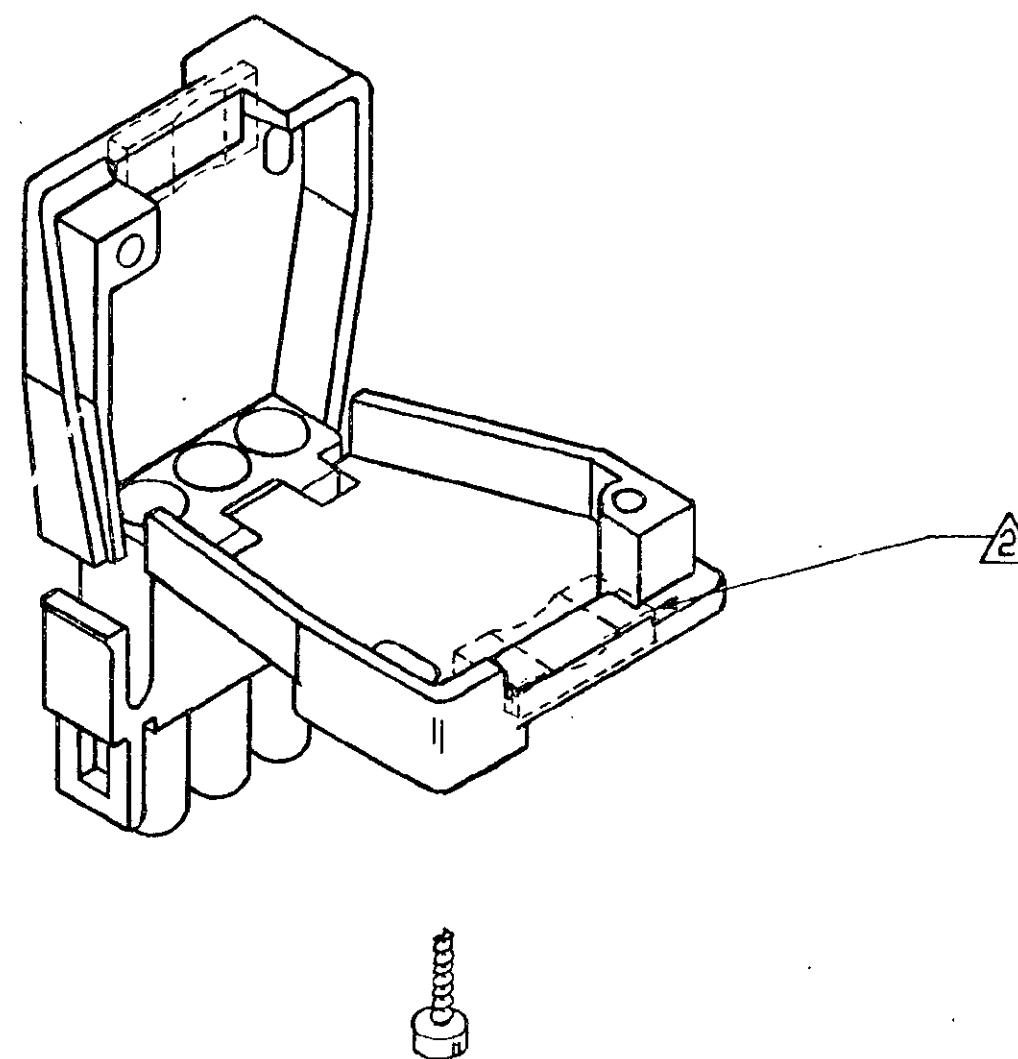
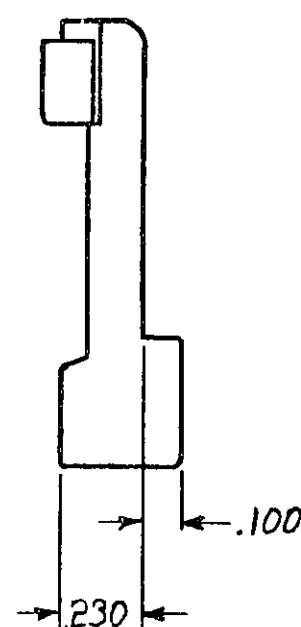
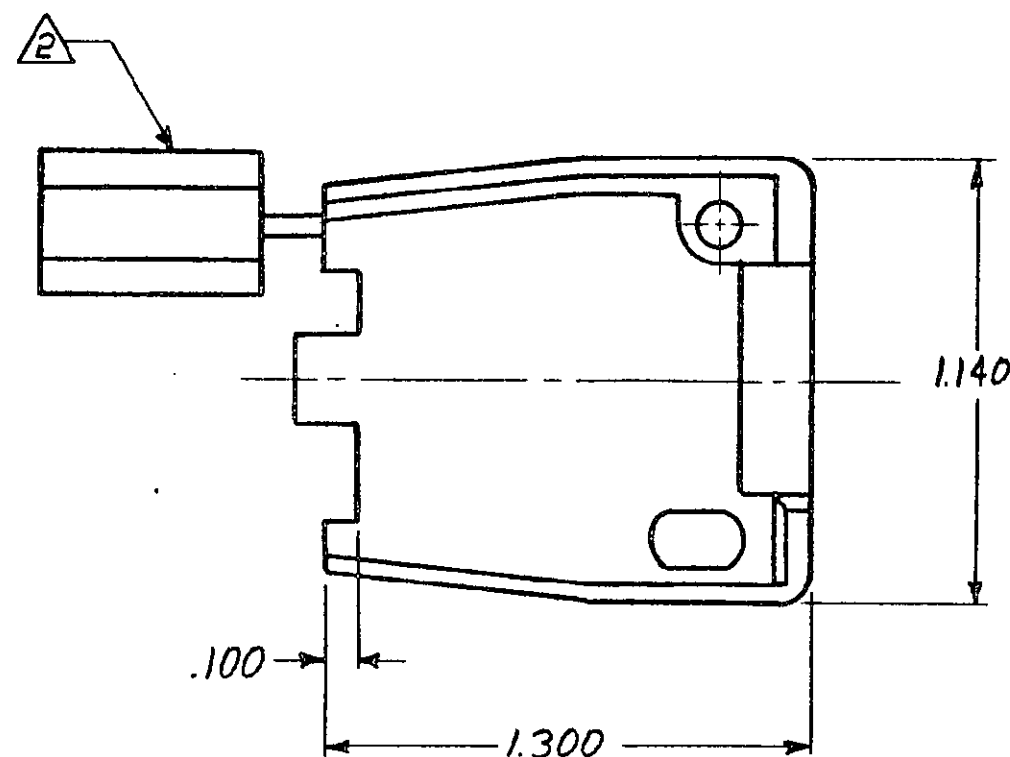

C-640714

640714

		NYLON 94V-0		640714-1	
		MATERIAL		PART NO	
WIRE BUNDLE		UNLESS OTHERWISE SPECIFIED DIMENSIONS ARE IN INCHES.		CONTRACT NO	
WITHOUT INSERT	MAX 3 @ .190 DIA	TOLERANCES ON: DECIMALS ± .015 ANGLES ±		DR C. ERISMAN 10-24-78	
WITH INSERT	MIN 3 @ .040 DIA	MATERIAL SEE TABLE		CHK D.S. Heide 11/1/78	
		FINISH SEE TABLE		APPD J.C.M. 11-1-78	
				APPD	
				DSGN APPD	
				OTHER APPD	
		SIZE	CODE IDENT NO	DRAWING NO	
		C	00779	640714	
		SCALE NTS		SHEET 1 OF 1	



STRAIN RELIEF AND INSERT,
3 CIRCUIT, UNIVERSAL MATE-N-LOK™