

© COPYRIGHT 1978 BY AMP INCORPORATED, HARRISBURG, PA. ALL INTERNATIONAL RIGHTS RESERVED. AMP INCORPORATED PRODUCTS COVERED BY U. S. AND FOREIGN PATENTS AND/OR PATENTS PENDING.

- 1 SHEET METAL SCREWS NOT SUPPLIED.
- 2 INSERT IS ATTACHED TO STRAIN RELIEF AS AN ADDITIONAL ADJUSTMENT FOR SMALL WIRE BUNDLES, IT SHOULD BE CUT OFF AND POSITIONED AS SHOWN BY DOTTED LINES.
- 3 TWO REQUIRED PER CONNECTOR.
- 4. DETACHABLE INSERT MAY SEPARATE FROM STRAIN RELIEF BODY DURING SHIPPING.

REVISIONS						
P	F	ZONE	LTR	DESCRIPTION	DATE	APPROVED
✓	✓		C	REV PER EC 0730-0201-94	4-26-95	JH RS
✓						
✓						

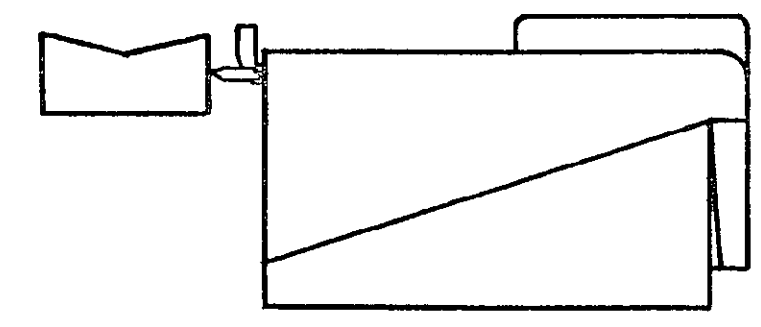

(2 REQ'D) #6 X .625 LG. TYPE "B" PAN HEAD SHEET METAL SCREW

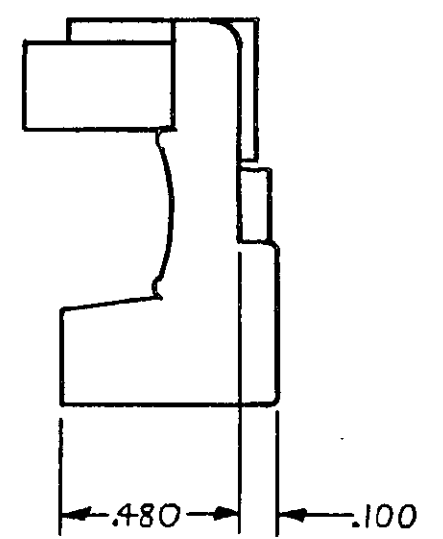
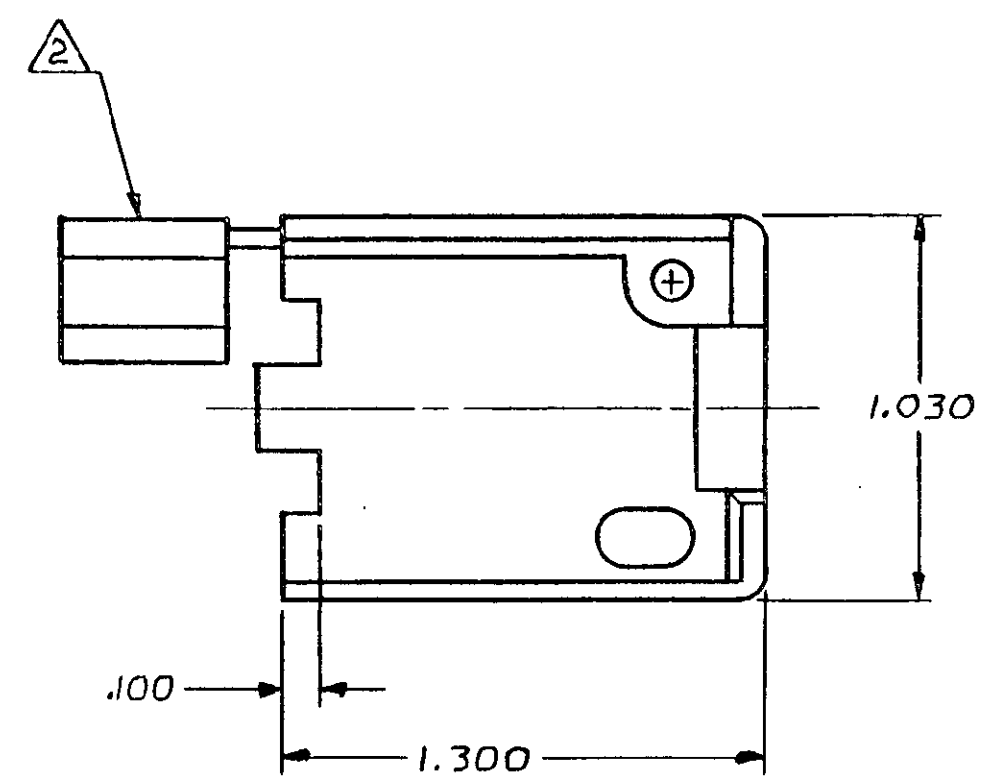
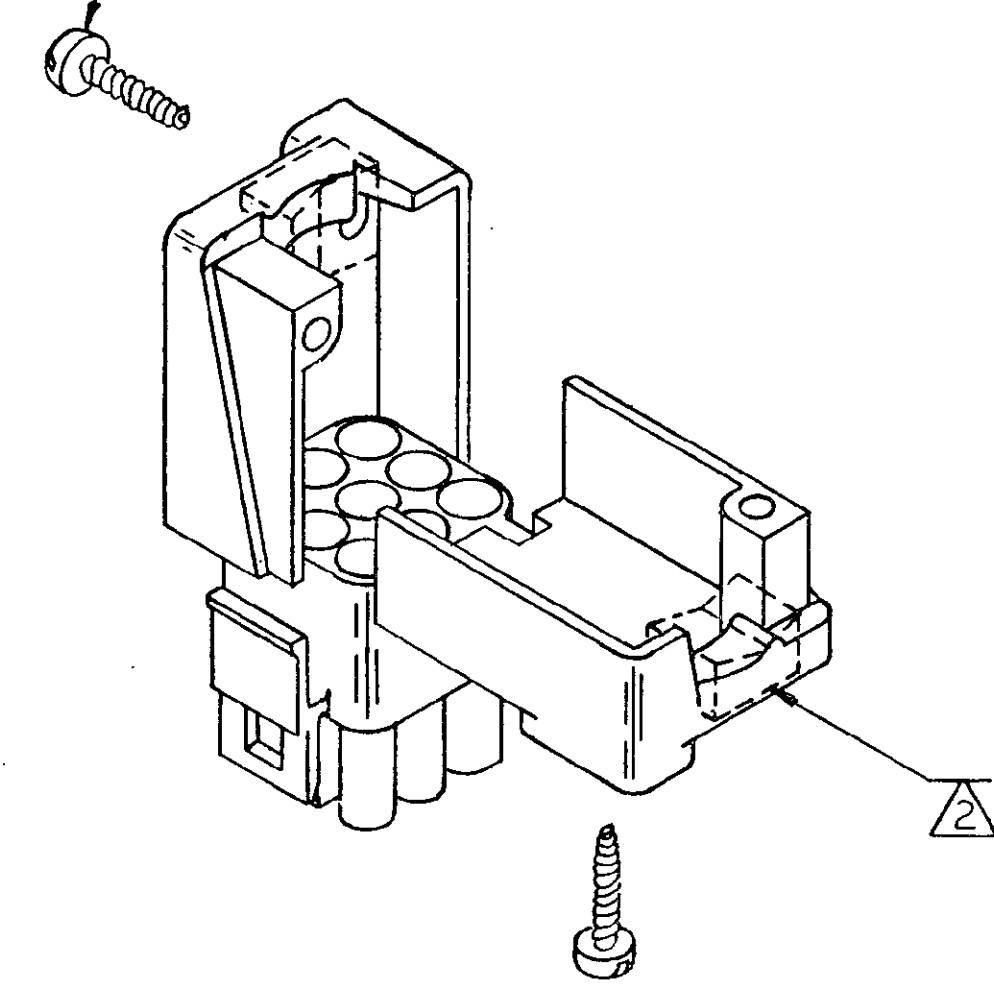

	WIRE BUNDLE DIA
WITHOUT INSERT	.650 MAX.
WITH INSERT	.120 MIN.

UNLESS OTHERWISE SPECIFIED DIMENSIONS ARE IN INCHES. TOLERANCES ON: DECIMALS ±.015 ANGLES ±	CONTRACT NO
MATERIAL SEE TABLE	DR M. FEHER 3-12-79
FINISH SEE TABLE	CHK D.S. Heide 3/22/79
	APPD J.C. M... 3-22-79
	DSGN APPD
	OTHER APPD

NYLON 94V-0	640716-1	3
MATERIAL	PART NC	
AMP INCORPORATED Harrisburg, Pa.		
NAME	STRAIN RELIEF FOR 9 CIRCUIT UNIVERSAL MATE-N-LOK™ CONNECTOR	
SIZE	CODE IDENT NO	DRAWING NO
C	00779	640716
SCALE 2-1	SHEET 1 OF 1	