

© COPYRIGHT 1978 BY AMP INCORPORATED, HARRISBURG, PA.
ALL INTERNATIONAL RIGHTS RESERVED. AMP INCORPORATED PRODUCTS
COVERED BY U. S. AND FOREIGN PATENTS AND/OR PATENTS PENDING.

- ⚠ SHEET METAL SCREWS NOT SUPPLIED.
- ⚠ INSERT IS ATTACHED TO STRAIN RELIEF. AS AN ADDITIONAL ADJUSTMENT FOR SMALL WIRE BUNDLES, IT SHOULD BE CUT OFF AND POSITIONED AS SHOWN BY DOTTED LINES.
- ⚠ TWO REQUIRED PER CONNECTOR.
- 4. DETACHABLE INSERT MAY SEPARATE FROM STRAIN RELIEF BODY DURING SHIPPING.

REVISIONS					
P	F	ZONE/LTR	DESCRIPTION	DATE	APPROVED
✓	✓	C	REV PER EC 0730-0201-94	4/26/95	JH RS
✓					
✓					

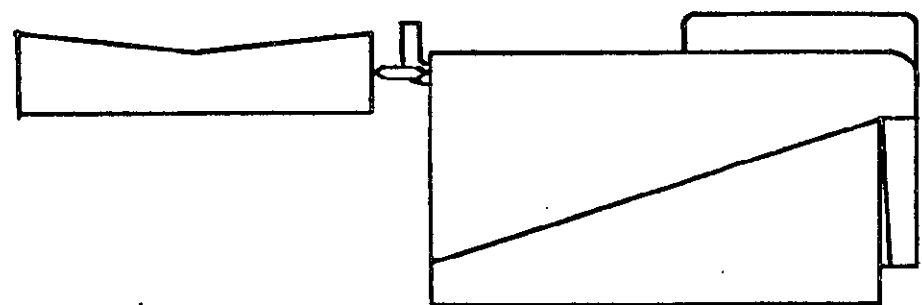

(2 REQ'D) #6 X .625 LG. TYPE "B" PAN HEAD SHEET METAL SCREW ⚠

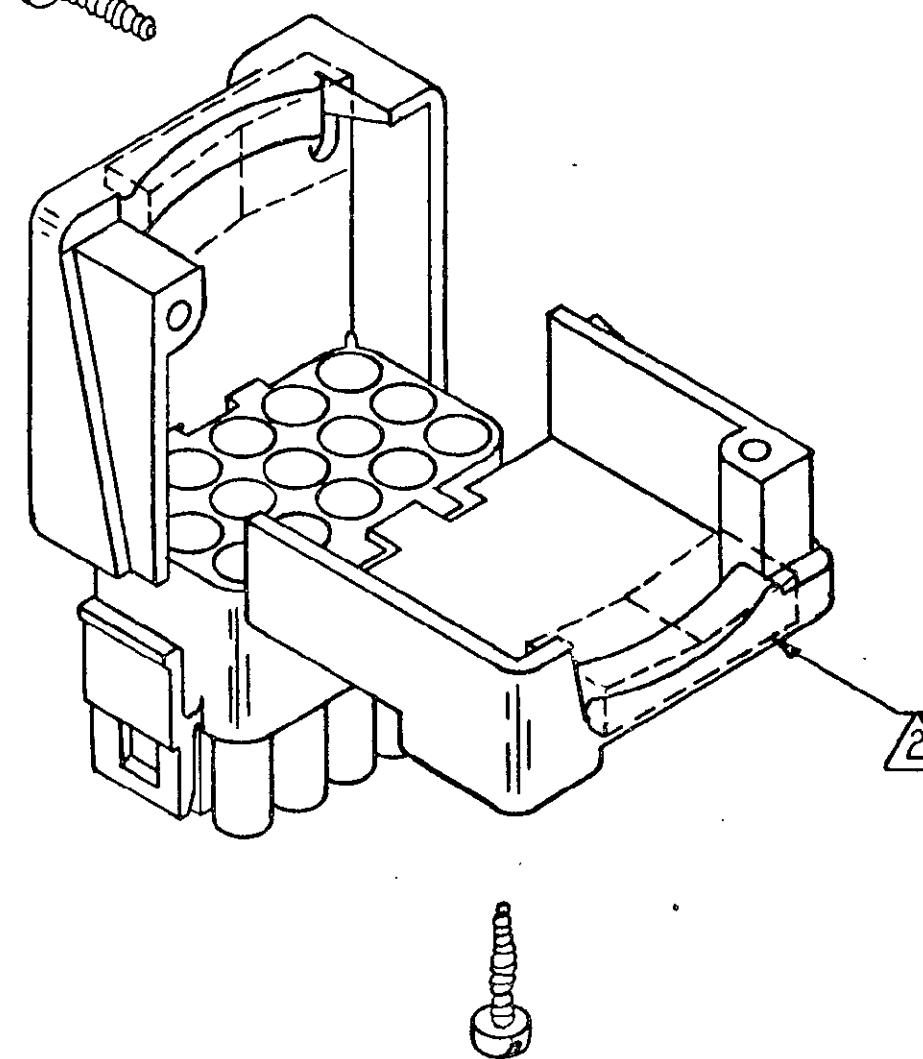
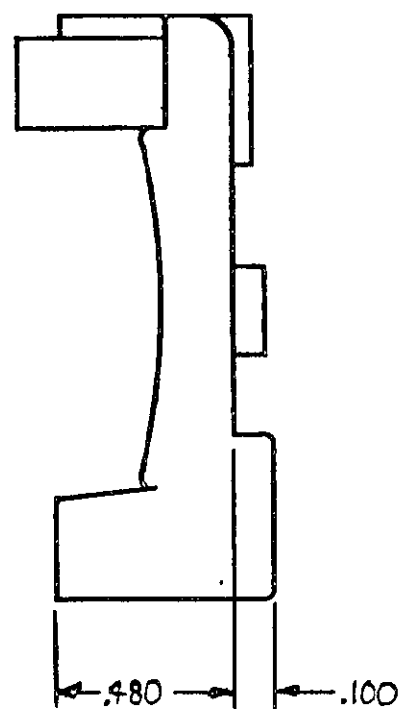
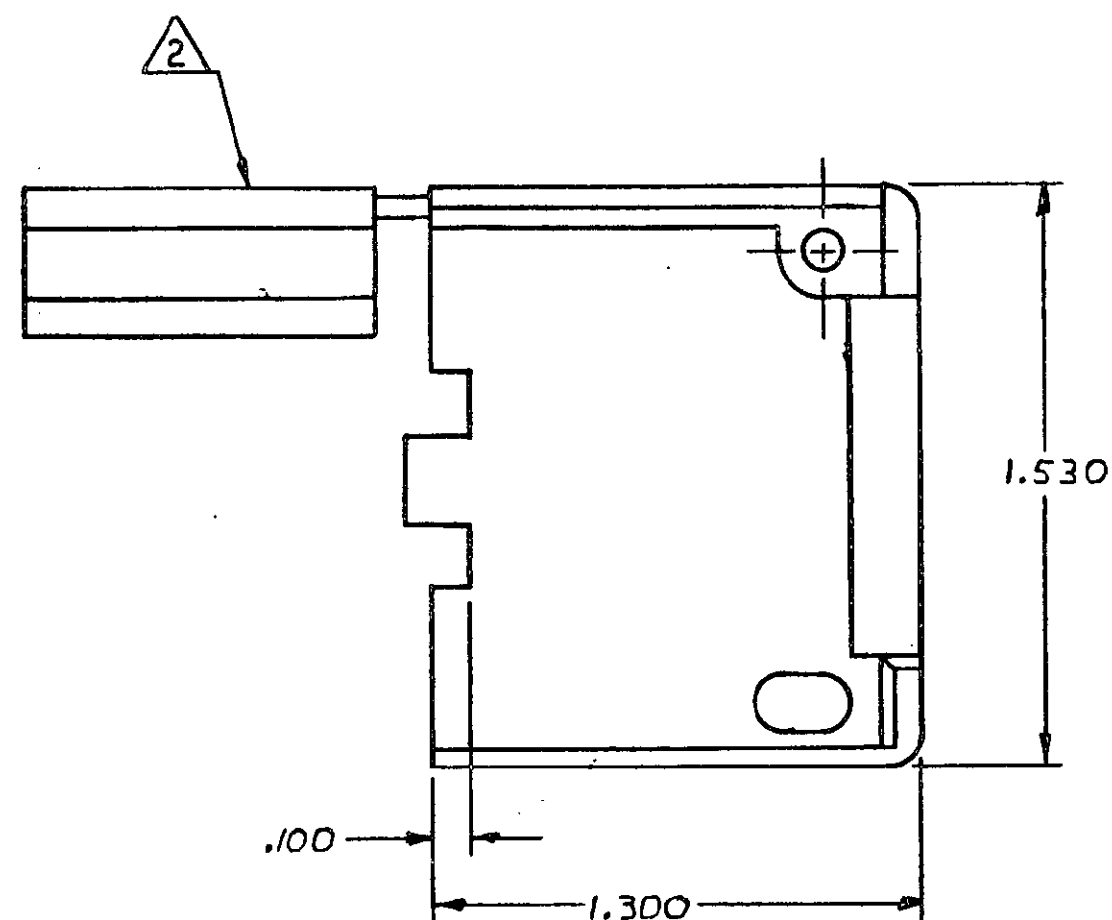

NYLON 94V-0	640718-1	3
MATERIAL	PART NO	

	WIRE BUNDLE DIA.
WITHOUT INSERT	.850 MAX
WITH INSERT	.200 MIN

UNLESS OTHERWISE SPECIFIED DIMENSIONS ARE IN INCHES.
TOLERANCES ON:
DECIMALS ± .015
ANGLES ±

MATERIAL
SEE TABLE

FINISH
SEE TABLE

CONTRACT NO

DR M. FEHER 3-12-79

CHK D.S. Heidt 3/22/79

APPD J.C.M. 3-22-79

DSGN APPD

OTHER APPD

AMP AMP INCORPORATED
Harrisburg, Pa.

NAME
STRAIN RELIEF FOR 15 CIRCUIT
UNIVERSAL MATE-N-LOK™ CONNECTOR

SIZE CODE IDENT NO DRAWING NO
C 00779 640718

SCALE 2-1 SHEET 1 OF 1