



AZM300Z-I2-ST-SD2P-DU

- Repeated individual coding with RFID technology
- Coding level "High" according to ISO 14119
- Connector M12, 8-pole
- Power to unlock
- Guard locking monitored
- serial diagnostic output
- Hygienic design
- Protection class IP 69
- Suitable for mounting to profile systems
- Thermoplastic enclosure
- RFID-technology for needs-based protection against tampering
- 3 different directions of actuation
- Compact design
- 3 LEDs to show operating conditions
- Suitable for hinged and sliding guards
- Series-wiring
- Manual release

Data

Ordering data

Product type description	AZM300Z-I2-ST-SD2P-DU
Article number (order number)	103047256
EAN (European Article Number)	4030661616902

Approvals - Standards

Certificates	TÜV cULus ECOLAB EAC FCC IC
--------------	--

General data

Standards	EN ISO 13849-1 EN ISO 14119 EN IEC 60947-5-3 EN IEC 61508
Coding	Individual coding, multiple teaching
Coding level according to EN ISO 14119	High
Working principle	RFID
Frequency band RFID	125 kHz
Transmitter output RFID, maximum	-6 dB/m
Enclosure material	Plastic, glass-fibre reinforced thermoplastic, self-extinguishing
Time to readiness, maximum	5,000 ms
Duration of risk, maximum	200 ms
Reaction time, switching off safety outputs via actuator, maximum	100 ms
Reaction time, switching off safety outputs via safety inputs, maximum	1.5 ms

General data - Features

Power to unlock	Yes
Solenoid interlock monitored	Yes
Serial diagnostics	Yes
Latching	Yes
Manual release	Yes
Short circuit detection	Yes
Cross-circuit detection	Yes
Series-wiring	Yes
Safety functions	Yes
Integral system diagnostics, status	Yes
Number of fail-safe digital outputs	2

Safety classification

Standards	EN ISO 13849-1 EN IEC 61508
-----------	--------------------------------

Safety classification - Interlocking function

Performance Level, up to	e
Category	4
PFH value	5.20×10^{-10} /h
PFD value	4.50×10^{-5}
Safety Integrity Level (SIL), suitable for applications in	3
Mission time	20 Year(s)

Mechanical data

Mechanical life, minimum	1,000,000 Operations
Note (Mechanical life)	When using as door stop: ≥ 50.000 operations (door mass ≤ 5 kg and actuating speed ≤ 0.5 m/s)
Angular misalignment between solenoid interlock and actuator, maximum	2 °
Holding force F_{Zh} in accordance with EN ISO 14119	1,150 N
Holding force F_{max} , maximum	1,500 N
Latching force, adjustable, position 1	25 N
Latching force, adjustable, position 2	50 N
Type of the fixing screws	2x M6
Tightening torque of the fixing screws, minimum	6 Nm
Tightening torque of the fixing screws, maximum	7 Nm

Mechanical data - Switching distances according EN IEC 60947-5-3

Assured switching distance "ON" S	1 mm
ao	
Assured switching distance "OFF" S	20 mm
ar	
Switch distance, typical	2 mm

Mechanical data - Connection technique

Termination	Connector M12, 8-pole, A-coded
Length of sensor chain, maximum	200 m
Note (length of the sensor chain)	Cable length and cross-section change the voltage drop depending on the output current
Note (series-wiring)	Unlimited number of devices, observe external line fusing, max. 31 devices in case of serial diagnostic SD

Mechanical data - Dimensions

Length of sensor	120 mm
Width of sensor	87.5 mm
Height of sensor	35 mm

Ambient conditions

Degree of protection	IP67 IP69 IP66
Ambient temperature, minimum	+0 °C
Ambient temperature, maximum	+60 °C
Storage and transport temperature, minimum	-10 °C
Storage and transport temperature, maximum	+90 °C
Relative humidity, maximum	93 %
Note (Relative humidity)	non-condensing non-icing

Resistance to vibration to EN 60068-2-6	10 ... 150 Hz, amplitude 0.35 mm
Resistance to shock	30 g / 11 ms
Protection class	III
Permissible installation altitude above sea level, maximum	2,000 m

Ambient conditions - Insulation values

Rated insulation voltage U_i	32 VDC
Rated impulse withstand voltage U_{imp}	0.8 kV
Overvoltage category	III
Degree of pollution to IEC/EN 60664-1	3

Electrical data

Operating voltage, minimum	20.4 VDC
Operating voltage, maximum	26.4 VDC
Note (Power supply, general)	stabilised PELV power supply
No-load supply current I_0 , maximum	100 mA
Current consumption with magnet ON, average	200 mA
Current consumption with magnet ON, peak	350 mA / 200 ms
Required rated short-circuit current to EN 60947-5-1	100 A
External wire and device fuse rating	2 A gG
Switching frequency, maximum	0.5 Hz

Electrical data - Magnet control

Designation, Magnet control	IN
-----------------------------	----

Switching thresholds	-3 V ... 5 V (Low) 15 V ... 30 V (High)
Magnet switch-on time	100 %
Test pulse duration, maximum	5 ms
Test pulse interval, minimum	40 ms
Classification ZVEI CB24I, Sink	C0
Classification ZVEI CB24I, Source	C1 C2 C3

Electrical data - Safety digital inputs

Designation, Safety inputs	X1 and X2
Switching thresholds	-3 V ... 5 V (Low) 15 V ... 30 V (High)
Current consumption at 24V	5 mA
Test pulse duration, maximum	1 ms
Test pulse interval, minimum	100 ms
Classification ZVEI CB24I, Sink	C1
Classification ZVEI CB24I, Source	C1 C2 C3

Electrical data - Safety digital outputs

Designation, Safety outputs	Y1 and Y2
Design of control elements	short-circuit proof, p-type
Voltage drop U_d , maximum	4 V
Leakage current I_r , maximum	0.5 mA
Voltage, Utilisation category DC-12	24 VDC
Current, Utilisation category DC-12	0.25 A
Voltage, Utilisation category DC-13	24 VDC
Current, Utilisation category DC-13	0.25 A
Test pulse duration, maximum	0.5 ms
Test pulse interval, typical	1000 ms

Classification ZVEI CB24I, Source C2

Classification ZVEI CB24I, Sink C1
C2

Electrical data - Diagnostic outputs

Designation, Diagnostic outputs OUT
Voltage drop U_d , maximum 4 V
Voltage, Utilisation category DC-12 24 VDC
Current, Utilisation category DC-12 0.05 A
Voltage, Utilisation category DC-13 24 VDC
Current, Utilisation category DC-13 0.05 A

Electrical data - Serial diagnostic SD

Operation current 150 mA
Wiring capacitance 50 nF

Status indication

Note (LED switching conditions display) Operating condition: LED green
Error / functional defect: LED red
Supply voltage UB: LED green

Pin assignment

PIN 1 A1 Supply voltage UB
PIN 2 X1 Safety input 1
PIN 3 A2 GND
PIN 4 Y1 Safety output 1
PIN 5 OUT serial diagnostic output
PIN 6 X2 Safety input 2
PIN 7 Y2 Safety output 2
PIN 8 IN serial diagnostic input

A

Power to lock

(5)

without

Manual release

N

Emergency release

T

Emergency exit

T 8

Emergency exit, distance 8.5 mm

Pictures

Product picture (catalogue individual photo)



ID: kazm3f26

| 905.6 kB | .jpg | 352.425 x 440.619 mm - 999 x 1249 px - 72 dpi

| 59.1 kB | .png | 74.083 x 92.428 mm - 210 x 262 px - 72 dpi

Dimensional drawing basic component

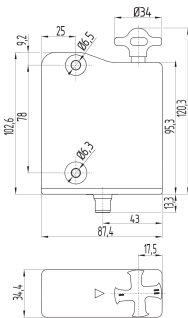

ID: 5azm3g02

| 73.9 kB | .ai | 210.002 x 297 mm - 595 x 841 px - 72 dpi

| 5.8 kB | .png | 74.083 x 124.531 mm - 210 x 353 px - 72 dpi

| 190.4 kB | .jpg | 352.778 x 593.372 mm - 1000 x 1682 px - 72 dpi

| 10.7 kB | .png | 29.803 x 50.038 mm - 352 x 591 px - 300 dpi

Dimensional drawing miscellaneous

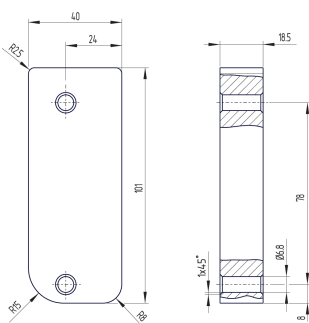

ID: kazm3g01

| 23.7 kB | .cdr |

| 133.3 kB | .jpg | 352.778 x 366.889 mm - 1000 x 1040 px - 72 dpi

Wiring example

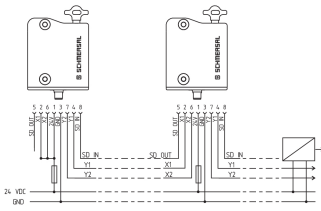

ID: kazm3l02

| 61.7 kB | .cdr |

| 108.2 kB | .jpg | 352.778 x 219.075 mm - 1000 x 621 px - 72 dpi

Contact arrangement

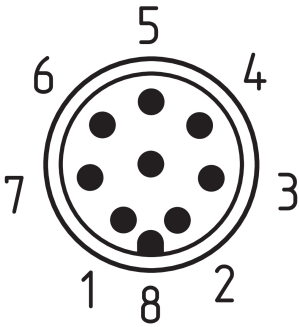

ID: km23-k8b

| 5.3 kB | .png | 73.731 x 79.728 mm - 209 x 226 px - 72 dpi

| 139.8 kB | .jpg | 352.778 x 380.647 mm - 1000 x 1079 px - 72 dpi

Schmersal Ltd., Sparrowhawk Close, WR14 1GL Malvern

The details and data referred to have been carefully checked. Images may diverge from original. Further technical data can be found in the manual. Technical amendments and errors possible.

Generated on: 30/09/2022, 07:06