



PXIE-DMM5100 Bundle

Expandable PXI bundle based on PXI-4065
Digital Multimeter, 6 1/2-Digit, 300V, 3A

Specifications

PXIE-1083 and PXI-4065

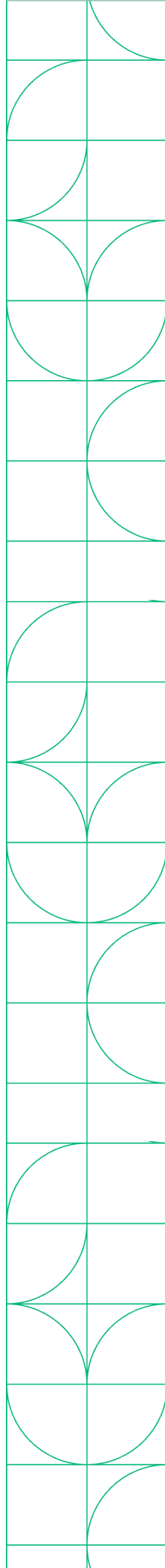

PXI DMM Bundle

In the Box

PXIe-DMM5100 Bundle

Accessories:



PXI-4065
(Digital Multimeter)



PXIe-1083
(5-Slot PXIe Chassis)

- Thunderbolt cable
- Power cable (varied by PN)
 - 867114-01 (US)
 - 867114-02 (EUR)
 - 867114-03 (Generic)

Recommended Software

Test Workflow P/N: 788509-35

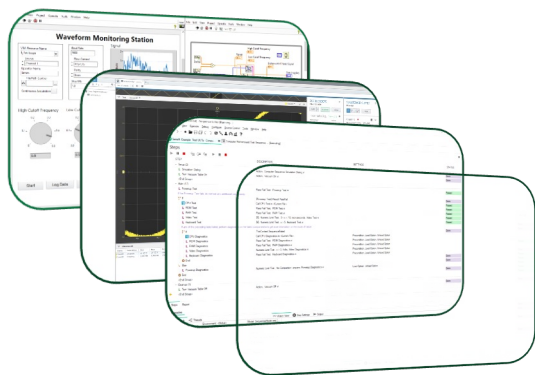

Test Workflow is a bundle of select NI software featuring engineering-specific tools that help test professionals accomplish anything from their day-to-day work to overcoming their most challenging obstacles.

Test Workflow includes:

- **LabVIEW** - a graphical programming environment engineers use to develop automated research, validation, and production test systems.
- **InstrumentStudio** - an application software that provides an integrated approach to interactive PXI measurements.
- **TestStand** - a test executive software that accelerates system development and deployment for engineers in validation and production.
- And more NI Software!

Table of Contents

This document combines the PDFs of this bundle together. The page numbers in the table of contents correspond to the page number of PDF the component's documentation begins.

PXIe-1083 Specifications.....	3
PXIe-4065 Specifications.....	16



PXle-1083 Specifications



PXIe-1083 Specifications

This document contains specifications for the PXIe-1083 chassis.

Electrical

The following section provides information about the PXIe-1083 AC input and DC output.

AC Input

Input rating	100 VAC to 240 VAC, 50 Hz/60 Hz, 6 A to 3 A
Operating voltage range ¹	90 VAC to 264 VAC
Nominal input frequency	50 Hz/60 Hz
Operating frequency range ¹	47 Hz to 63 Hz
Efficiency	78% typical
Over-current protection	Internal fuse in line
Main power disconnect	The AC power cable provides main power disconnect. Do not position the equipment so that it is difficult to disconnect the power cord. The front-panel power switch causes the internal chassis power supply to provide DC power to the PXI Express backplane.



Caution Disconnect power cord to completely remove power.

DC Output

DC output characteristics of the PXIe-1083.

Voltage Rail	Maximum Current	Load Regulation	Maximum Ripple and Noise (20 MHz BW)
+5V_AUX	1.0 A	±5%	50 mVpp
+12 V	30.1 A	±5%	120 mVpp
+5 V	25.1 A	±5%	50 mVpp
+3.3 V	30.7 A	±5%	50 mVpp
-12 V	0.75 A	±5%	120 mVpp

Maximum total available power for the PXIe-1083 is 293 W.

The maximum combined power available on +3.3 V and +5 V is 180 W.

The maximum power available for each Thunderbolt port is 15 W (5 V/3 A).

Table 1. Backplane Slot Current Capacity

Slot	+5 V	V (I/O)	+3.3 V	+12 V	-12 V	5 V _{AUX}
Hybrid Peripheral Slot with PXI-5 Peripheral	-	-	3 A	6 A	-	1 A
Hybrid Peripheral Slot with PXI-1 Peripheral	6 A	5 A	6 A	1 A	1 A	-



Note PCI V(I/O) pins in Hybrid Peripheral Slots are connected to +5 V.



Note The maximum power dissipated in a peripheral slot should not exceed 58 W. Refer to the **Operating Environment** section for ambient temperature considerations at 58 W.

Over-current protection	All outputs are protected from short circuit and overload, they recover and return to regulation when the overload is removed and the power is cycled.
Over-voltage protection	+3.3 V clamped at 3.7 V to 4.3 V, +5 V clamped at 5.7 V to 6.5 V, +12 V clamped at 13.4 V to 15.6 V

Chassis Cooling

Module cooling	Forced air circulation (positive pressurization) through one 150 CFM fan
Module slot airflow direction	Bottom of module to top of module
Module intake	Bottom of chassis
Module exhaust	Top, right side of chassis
Slot cooling capacity	58 W; slot 6 supports 58 W cooling with high fan mode
Power supply cooling	Forced air circulation through integrated fans
Power supply intake	Front and left side chassis
Power supply exhaust	Rear of chassis
Minimum chassis cooling clearances	
Above	44.45 mm (1.75 in.)
Rear	44.45 mm (1.75 in.)
Sides	44.45 mm (1.75 in.)
Below	
Rack	44.45 mm (1.75 in.)
Desktop	25.4 mm (1.00 in.)

Environmental

Maximum altitude	2,000 m (6,560 ft.), 800 mbar (at 25 °C ambient, high fan mode)
Pollution Degree	2

Indoor use only.

Operating Environment

Ambient temperature range	
When all peripheral modules require ≤ 38 W cooling capacity per slot	0 °C to 50 °C (IEC 60068-2-1 and IEC 60068-2-2.) ² Meets MIL-PRF-28800F Class 3 low temperature limit and high temperature limit.
When any peripheral module requires > 38 W cooling capacity per slot	0 °C to 40 °C (IEC 60068-2-1 and IEC 60068-2-2.) ² Meets MIL-PRF-28800F Class 3 low temperature limit and MIL-PRF-28800F Class 4 high temperature limit.
Relative humidity range	20% to 80%, noncondensing

Storage Environment

Ambient temperature range	-40 °C to 71 °C (IEC-60068-2-1 and IEC-60068-2-2.) ^[3] Meets MIL-PRF-28800F Class 3 limits.
Relative humidity range	10% to 95%, noncondensing

Shock and Vibration

Operational shock	30 g peak, half-sine, 11 ms pulse (IEC-60068-2-27.) ³ Meets MIL-PRF-28800F Class 2 limits.
Operational random vibration	5 to 500 Hz, 0.3 g _{rms}
Non-operating vibration	5 to 500 Hz, 2.4 g _{rms} (IEC 60068-2-64.) ³ Non-operating test profile exceeds the requirements of MIL-PRF-28800F, Class 3.

Acoustic Emissions

Sound Pressure Level (at Operator Position)

(Tested in accordance with ISO 7779. Meets MIL-PRF-28800F requirements.)

38 W Profile

Auto fan (up to 30 °C ambient)	33.7 dBA
High fan	50.8 dBA

58 W Profile

Auto fan (up to 30 °C ambient)	54.7 dBA
High fan	55.3 dBA

Sound Power Level

38 W Profile

Auto fan (up to 30 °C ambient)	44.9 dBA
High fan	60.3 dBA

58 W Profile

Auto fan (up to 30 °C ambient)	63.4 dBA
High fan	64.2 dBA



Note The protection provided by the PXIe-1083 can be impaired if it is used in a manner not described in this document.

Safety Compliance Standards

This product is designed to meet the requirements of the following electrical equipment safety standards for measurement, control, and laboratory use:

- IEC 61010-1, EN 61010-1
- UL 61010-1, CSA C22.2 No. 61010-1



Note For safety certifications, refer to the product label or the [Product Certifications and Declarations](#) section.

EMC Guidelines

This product was tested and complies with the regulatory requirements and limits for electromagnetic compatibility (EMC) stated in the product specifications. These requirements and limits provide reasonable protection against harmful interference when the product is operated in the intended operational electromagnetic environment.

This product is intended for use in industrial locations. However, harmful interference may occur in some installations, when the product is connected to a peripheral device or test object, or if the product is used in residential areas. To minimize interference with radio and television reception and prevent unacceptable performance degradation, install and use this product in strict accordance with the instructions in the product documentation.

Furthermore, any changes or modifications to the product not expressly approved by NI could void your authority to operate it under your local regulatory rules.

EMC Notices

Refer to the following notices for cables, accessories, and prevention measures necessary to ensure the specified EMC performance.



Notice

For EMC declarations and certifications, and additional information, refer to the [Product Certifications and Declarations](#) section.



Notice Changes or modifications to the product not expressly approved by NI could void your authority to operate the product under your local regulatory rules.



Notice Operate this product only with shielded cables and accessories.

Electromagnetic Compatibility Standards

This product meets the requirements of the following EMC standards for electrical equipment for measurement, control, and laboratory use:

- EN 61326-1 (IEC 61326-1): Class A emissions; Basic immunity
- EN 55011 (CISPR 11): Group 1, Class A emissions

- AS/NZS CISPR 11: Group 1, Class A emissions



Note Group 1 equipment (per CISPR 11) is any industrial, scientific, or medical equipment that does not intentionally generate radio frequency energy for the treatment of material or inspection/analysis purposes.



Note In Europe, Canada, Australia, and New Zealand (per CISPR 11) Class A equipment is intended for use in nonresidential locations.

CE Compliance

This product meets the essential requirements of applicable European Directives, as follows:

- 2014/35/EU; Low-Voltage Directive (safety)
- 2014/30/EU; Electromagnetic Compatibility Directive (EMC)
- 2011/65/EU; Restriction of Hazardous Substances (RoHS)

Product Certifications and Declarations

Refer to the product Declaration of Conformity (DoC) for additional regulatory compliance information. To obtain product certifications and the DoC for NI products, visit ni.com/product-certifications, search by model number, and click the appropriate link.

Environmental Management

NI is committed to designing and manufacturing products in an environmentally responsible manner. NI recognizes that eliminating certain hazardous substances from our products is beneficial to the environment and to NI customers.

For additional environmental information, refer to the **Engineering a Healthy Planet** web page at ni.com/environment. This page contains the environmental

regulations and directives with which NI complies, as well as other environmental information not included in this document.

EU and UK Customers

-  Waste Electrical and Electronic Equipment (WEEE)—At the end of the product life cycle, all NI products must be disposed of according to local laws and regulations. For more information about how to recycle NI products in your region, visit ni.com/environment/weee.

电子信息产品污染控制管理办法 (中国 RoHS)

-  中国 RoHS— NI 符合中国电子信息产品中限制使用某些有害物质指令(RoHS)。关于 NI 中国 RoHS 合规性信息，请登录 ni.com/environment/rohs_china。(For information about China RoHS compliance, go to ni.com/environment/rohs_china.)

Backplane

Size	3U-sized; 5 peripheral slots. Compliant with IEEE 1101.10 mechanical packaging. PXI Express Specification compliant. Accepts both PXI Express and CompactPCI (PICMG 2.0 R 3.0) 3U modules.
Backplane bare-board material	UL 94 V-0 Recognized
Backplane connectors	Conforms to IEC 917 and IEC 1076-4-101, UL 94 V-0 rated

System Synchronization Clocks

10 MHz System Reference Clock: PXI_CLK10

Maximum slot-to-slot skew	250 ps
Accuracy	± 25 ppm max (guaranteed over the operating temperature range)
Maximum jitter	5 ps RMS phase-jitter (10 Hz–1 MHz range)
Duty-factor	45% to 55%
Unloaded signal swing	3.3 V \pm 0.3 V



Note For other specifications, refer to the **PXI-1 Hardware Specification**.

100 MHz System Reference Clock: PXIe_CLK100 and PXIe_SYNC100

Maximum slot-to-slot skew	100 ps
Accuracy	± 25 ppm max (guaranteed over the operating temperature range)
Maximum jitter	3 ps RMS phase-jitter (10 Hz to 12 kHz range), 2 ps RMS phase-jitter (12 kHz to 20 MHz range)
Duty-factor for PXIe_CLK100	45% to 55%
Absolute differential voltage (When terminated with a 50 Ω load to 1.30 V or Thévenin equivalent)	400 mV to 1000 mV



Note For other specifications, refer to the **PXI-5 PXI Express Hardware Specification**.

Mechanical

Standard chassis dimensions	
Height	177.1 mm (6.97 in.)
Width	257.1 mm (10.12 in.)
Depth	214.2 mm (8.43 in.)
Weight	6.7 kg (14.8 lb)
Chassis materials	Extruded Aluminum (6063-T5, 6060-T6), Cold Rolled Steel/Stainless Steel, Santoprene, Urethane Foam, PC-ABS, Nylon, Polyethylene
Finish	Conductive Clear Iridite on Aluminum, Electroplated Nickel on Cold Rolled Steel, Electroplated Zinc on Cold Rolled Steel

The following figures show the PXIe-1083 chassis dimensions. The holes shown are for installing the optional rack mount kits.

Figure 1. PXIe-1083 Chassis Dimensions (Front)

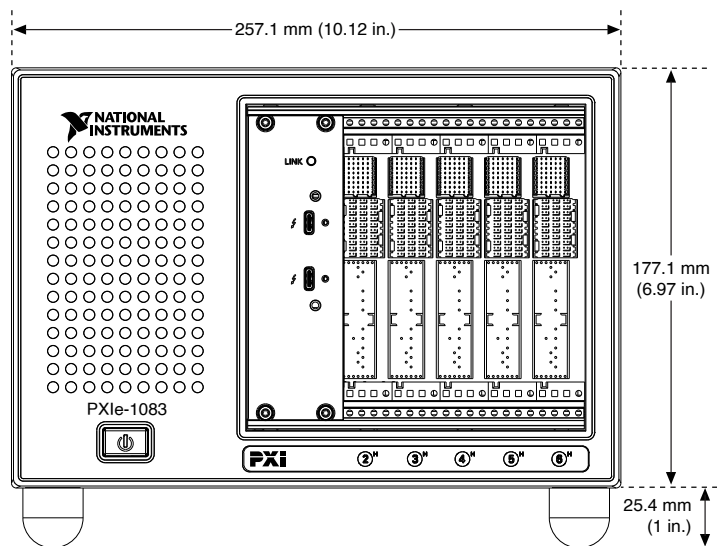

Figure 2. PXIe-1083 Chassis Dimensions (Side)

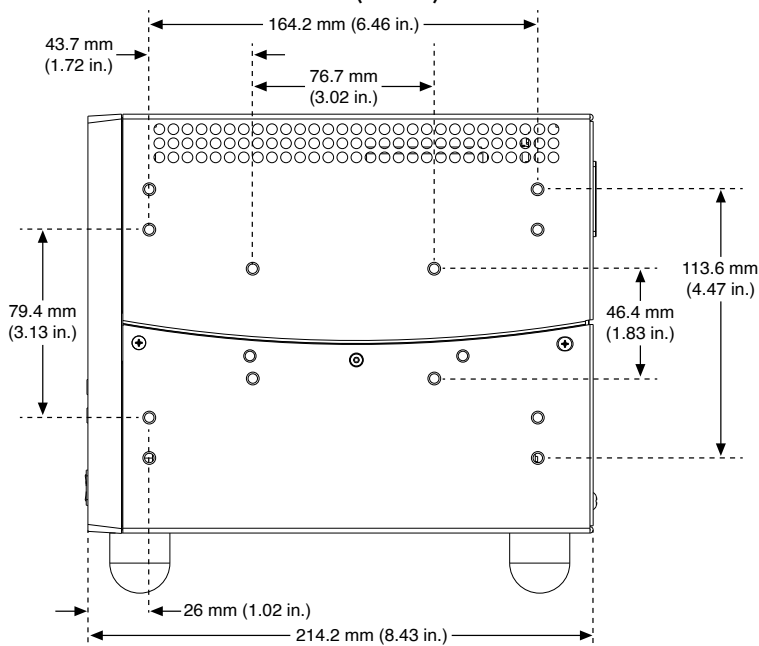
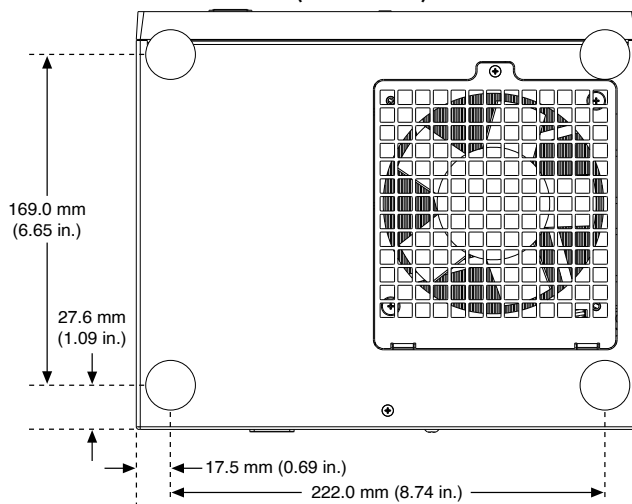

Figure 3. PXIe-1083 Chassis Dimensions (Bottom)



¹ The operating range is guaranteed by design.

² This product meets the requirements of the environmental standards for electrical equipment for measurement, control, and laboratory use.

³ This product meets the requirements of the environmental standards for electrical equipment for measurement, control, and laboratory use.

PXI-4065

Specifications



PXI-4065 Specifications

These specifications apply to the PXI-4065.

Definitions

Warranted specifications describe the performance of a model under stated operating conditions and are covered by the model warranty.

Characteristics describe values that are relevant to the use of the model under stated operating conditions but are not covered by the model warranty.

- **Typical** specifications describe the expected performance met by a majority of the models.
- **Nominal** specifications describe parameters and attributes that may be useful in operation.

Conditions

Specifications are valid under the following conditions unless otherwise noted.

- Ambient temperature of $T_{cal} \pm 5 \text{ }^\circ\text{C}$.^[1]
- Calibration interval of 1 year
- 30 minutes warm-up time
- niDMM Digits Resolution property or NIDMM_ATTR_RESOLUTION_DIGITS attribute set to 6.5
- niDMM Aperture Time Units property or NIDMM_ATTR_APERTURE_TIME_UNITS attribute set to Power Line Cycles
- niDMM Aperture Time property or NIDMM_ATTR_APERTURE_TIME attribute set to 10

DC Specifications

Resolution (digits)	Reading rate (S/s), specified for 60 Hz (and 50 Hz) operation	Aperture time (NPLC)	RMS noise (ppm of range), 10 V range
6½	0.6 (0.5)	100	0.06
	6 (5)	10	0.2
	10 (8.33)	6	0.25
5½	30 (25)	2	0.4
	60 (50)	1	0.55
	900	0.06	1.7
	1,500	0.04	2.5
4½	3,000	0.02	11.5

Figure 1. Noise Performance^[2]

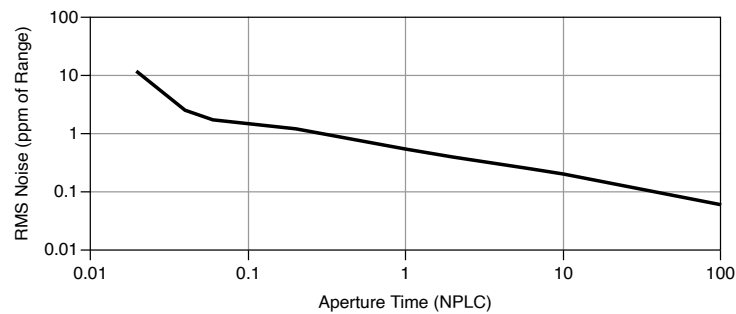

DC System Speed Characteristics

Range or function changes	10/s
Auto Range time, DC V	200 ms
Auto Range time, DC I	200 ms
Auto Range time, resistance	250 ms

Trigger latency	<1 μ s
Maximum trigger rate	2.5 kHz

DC Accuracy Specifications

Range	Resolution	Input resistance (10 M Ω , default), nominal	24 Hr ^[4] T _{cal} ^[5] ± 1 °C	90 day T _{cal} ± 5 °C	1 year T _{cal} ± 5 °C	Tempco ^[6] (ppm/°C)
100 mV ^[3]	100 nV	>10 G Ω , 10 M Ω	30 + 30	65 + 35	90 + 35	5 + 2
1 V	1 μ V	>10 G Ω , 10 M Ω	20 + 8	65 + 12	90 + 12	5 + 1
10 V	10 μ V	>10 G Ω , 10 M Ω	15 + 7	65 + 12	90 + 12	5 + 1
100 V	100 μ V	10 M Ω	20 + 8	75 + 12	110 + 12	9 + 1
300 V	1 mV	10 M Ω	20 + 24	75 + 40	110 + 40	9 + 1

Table 1. DC Voltage \pm (ppm of Reading + ppm of Range)

Range	Resolution	Burden voltage, typical	24 Hr ^[4] T _{cal} ^[5] ± 1 °C	90 day T _{cal} ± 5 °C	1 year T _{cal} ± 5 °C	Tempco ^[6] (ppm/°C)
10 mA	10 nA	<60 mV	50 + 100	300 + 200	500 + 200	30 + 20
100 mA	100 nA	<0.6 V	100 + 40	300 + 50	500 + 50	30 + 5
1 A	1 μ A	<0.35 V	500 + 60	800 + 100	1,000 + 100	65 + 10
3 A	3 μ A	<1 V	1,000 ^[7] + 200	1,200 ^[7] + 200	1,200 ^[7] + 200	65 + 20

Table 2. DC Current \pm (ppm of Reading + ppm of Range)

Range	Resolution	Test current, nominal	24 Hr ^[9] T _{cal} ^[10] ± 1 °C	90 day T _{cal} ± 5 °C	1 year T _{cal} ± 5 °C	Tempco ^[6] (ppm/°C)
100 Ω	100 $\mu\Omega$	1 mA	30 + 30	95 + 40	110 + 40	8 + 3
1 k Ω	1 m Ω	1 mA	20 + 8	95 + 20	110 + 20	8 + 1

Range	Resolution	Test current, nominal	24 Hr ^[9] T _{cal} ^[10] ±1 °C	90 day T _{cal} ±5 °C	1 year T _{cal} ±5 °C	Tempco ^[6] (ppm/°C)
10 kΩ	10 mΩ	100 μA	20 + 8	95 + 20	110 + 20	8 + 1
100 kΩ	100 mΩ	10 μA	20 + 8	95 + 20	110 + 20	8 + 1
1 MΩ	1 Ω	5 μA	20 + 12	110 + 24	125 + 24	10 + 1
10 MΩ ^[11]	10 Ω	500 nA	150 + 12	400 + 24	500 + 24	30 + 2
100 MΩ ^[11]	100 Ω	500 nA 10 MΩ	2,000 + 24	6,000 + 60	8,000 + 60	400 + 4

Table 3. Resistance^[8] (4-Wire and 2-Wire) ± (ppm of Reading + ppm of Range)

Range	Resolution	Test current, nominal	Accuracy
10 V	10 μV	100 μA, 1 mA (up to 3.5 V measurement for 1 mA test current)	Add 50 ppm of range and 50 ppm of reading to 10 V DC voltage specifications.

Table 4. Diode Test^[12]

DC Functions General Specifications

Overrange	105% of range except 300 V and 3 A range	
Maximum 4-wire lead resistance	Use the lesser of 10% of range or 1 kΩ	
DC voltage input bias current	<40 pA at 23 °C, typical	
Effective Common-Mode Rejection Ratio (CMRR) (1 kΩ resistance in LO lead) >150 dB second order DC noise rejection (for power-line frequency ±0.1%), 12 PLC aperture		
Aperture time (NPLC)	DC noise rejection	Normal mode rejection (for power-line frequency ±0.1%)
1	Normal	60 dB
2	Second-order	>85 dB

Aperture time (NPLC)	DC noise rejection	Normal mode rejection (for power-line frequency $\pm 0.1\%$)
10		

Table 5. Normal Mode Rejection Ratio (NMRR)

AC Specifications

Desired bandwidth	Recommended reading rate	Resolution (digits)
10 Hz to 100 kHz	1 S/s	6½
100 Hz to 100 kHz	10 S/s	5½
500 Hz to 100 kHz	100 S/s	4½

AC System Speed Characteristics

Range or function changes	10/s
Trigger latency	<1 μ s
Maximum trigger rate	2.5 kHz

AC Accuracy Specifications

Note All AC accuracy specifications apply to signal amplitudes greater than 2% of range.

Range (peak voltage)	Frequency	24 hr ^[13] $T_{cal} \pm 1\text{ }^{\circ}\text{C}$	1 year ^[14] $T_{cal} \pm 5\text{ }^{\circ}\text{C}$	Tempco ^[15] (%/°C)
200 mV (± 320 mV), 2 V (± 3.2 V), 20 V (± 32 V), 300 V (± 425 V)	10 Hz to 40 Hz	1.5 + 0.04	2 + 0.05	0.01 + 0.003
	> 40 Hz to 20 kHz	0.2 + 0.04	0.2 + 0.05	0.01 + 0.003
	> 20 kHz to 50 kHz	0.3 + 0.04	0.3 + 0.05	0.01 + 0.003

Range (peak voltage)	Frequency	24 hr ^[13] T _{cal} ±1 °C	1 year ^[14] T _{cal} ±5 °C	Tempco ^[15] (%/°C)
	> 50 kHz to 100 kHz	1.5 + 0.08	1.5 + 0.08	0.02 + 0.005

Table 6. AC Voltage (% of Reading + % of Range)

Range (peak current)	Frequency	24 hr ^[13] T _{cal} ±1 °C	1 year ^[14] T _{cal} ±5 °C	Tempco ^[15] (%/°C)
10 mA (± 16 mA), 100 mA (± 160 mA), 500 mA (± 780 mA), 3 A (± 4.25 A)	10 Hz to 40 Hz	1.6 to 0.05	2.1 + 0.05	0.015 + 0.03
	> 40 Hz to 5 kHz	0.3 + 0.05	0.3 + 0.06	0.015 + 0.03

Table 7. AC Current (% of Reading + % of Range)

Crest factor	Additional error (% of reading)
1 to 3	0.05%
3 to 4	0.1%
4 to 5	1% (for frequencies above 2 kHz)

Table 8. High Crest Factor Additional Error^[16]

AC Functions General Specifications

Input impedance	10 MΩ in parallel with 200 pF, nominal
Input coupling	AC coupling
Maximum Voltz-Hertz product	3 x 10 ⁷ V-Hz
Maximum DC voltage component	250 V
CMRR, 1 kΩ resistance in LO lead	70 dB (DC to 60 Hz)
Overrange	105% of range except 300 V, 3 A range

Temperature Accuracy Specifications^[17]

Type	Range	1 year $T_{cal} \pm 5 \text{ }^\circ\text{C}$		Tempco ($^\circ\text{C}_{reading}/^\circ\text{C}_{DMM}$) ^[20]	Resolution
		With Simulated Ref. Junction ^[18]	With PXI-2527 ^[19]		
J	-150 to 1200	0.3	1.0	0.03	0.1
	-210 to -150	0.4	1.2	0.03	0.1
K	-100 to 1200	0.4	1.0	0.03	0.1
	-200 to -100	0.4	1.5	0.03	0.1
N	-100 to 1300	0.3	1.0	0.03	0.1
	-200 to -100	0.6	1.5	0.03	0.1
T	-100 to 400	0.3	1.0	0.03	0.1
	-200 to -100	0.4	1.5	0.03	0.1
E	-150 to 1000	0.2	1.0	0.03	0.1
	-200 to -150	0.3	1.5	0.03	0.1
R	300 to 1760	0.6	1.8	0.06	0.1
	-50 to 300	1.4	1.9	0.06	0.1
S	400 to 1760	0.7	1.8	0.06	0.1
	-50 to 400	1.3	1.8	0.06	0.1
B	1100 to 1820	0.6	1.8	0.09	0.1
	400 to 1100	1.4	1.9	0.09	0.1

Table 9. Thermocouple Temperature Accuracy Specifications ($^\circ\text{C}$)

Range	1 year T_{cal} ^[18] $\pm 5 \text{ }^\circ\text{C}$	Tempco/ $^\circ\text{C}$ ^[22]	Resolution
-200 to 600	0.17	0.011	0.01

Table 10. RTD^[21] Temperature Accuracy Specifications ($^\circ\text{C}$)

Range	1 year T_{cal} ^[18] $\pm 5 \text{ }^\circ\text{C}$	Tempco/ $^\circ\text{C}$ ^[22]	Resolution
-80 to 150	0.08	0.002	0.01

Table 11. Thermistor Temperature Accuracy Specifications ($^\circ\text{C}$)

General Specifications

Maximum common-mode voltage	300 V AC _{rms} or DC
Measurement Category	II

Caution Do not use this device for connection to signals or for measurements within Measurement Categories III or IV.

Input Protection Characteristics

DC I and AC I	3.15 Amp, fused F 3.15 A 250 V, fast-acting user-replaceable fuse
Resistance, diode	Up to 300 V DC
DC V, AC V	Up to 300 V DC, 300 V AC _{rms} , 450 V AC peak

Fuse When this fuse symbol is marked on a device, take proper precautions.

Hazardous Voltage This icon denotes a warning advising you to take precautions to avoid electrical shock.

Calibration Interval

Calibration interval	1 year recommended
----------------------	--------------------

Warm-Up Time Characteristics

Warm-up time	30 minutes to rated accuracy
--------------	------------------------------

Trigger Characteristics

Input triggers

Types	Trigger, Sample Trigger (programmable edge)
Sources	Auxiliary connector (AUX I/O connector), PXI Trigger lines
Minimum pulse width	200 ns
Max samples per trigger	2.1×10^9
Trigger delay	0 to 149 s
Logic level	5 V TTL, LVTTTL

Output triggers

Types	Measurement Complete (programmable edge)
Destinations	Auxiliary connector (AUX I/O connector), PXI Trigger lines
Pulse width	1 μ s
Logic level	3.3 V

Note The AUX I/O connector is not isolated. It is not referenced to your measurement circuit. The connector is referenced to the ground of your

chassis. The digital signals on this connector should not operate beyond -0.5 to 5.5 V of your chassis ground. The trigger signals are TTL-compatible.

Power Consumption Characteristics

Power consumption	<3 W from PXI backplane
Rail voltage	Power consumption
12 V	<0.12 W
5.0 V	<1.50 W
3.3 V	<0.50 W

Table 12. PXI Power Consumption, Typical

Physical Characteristics

Dimensions	3 U, one slot, PXI/cPXI module 21.6 cm × 2.0 cm × 13.0 cm (8.5 in. × 0.8 in. × 5.1 in.)
Weight	351.5 g (12.4 oz)

Cleaning Statement

Caution Clean the hardware with a soft, nonmetallic brush. Make sure that the hardware is completely dry and free from contaminants before returning it to service.

Environment

Maximum altitude	2,000 m (at 25 °C ambient temperature)
------------------	--

Pollution Degree	2
------------------	---

Indoor use only.

Operating Environment

Ambient temperature range	0 to 55 °C (Tested in accordance with IEC 60068-2-1 and IEC 60068-2-2.)
Relative humidity range	10% to 90%, noncondensing

Storage Environment

Ambient temperature range	-40 °C to 70 °C (Tested in accordance with IEC 60068-2-1 and IEC 60068-2-2.)
Relative humidity range	5% to 95%, noncondensing (Tested in accordance with IEC 60068-2-56.)

Shock and Vibration

Operational shock	30 g peak, half-sine, 11 ms pulse (Tested in accordance with IEC 60068-2-27. Test profile developed in accordance with MIL-PRF-28800F.)
-------------------	---

Random vibration

Operating 5 Hz to 500 Hz, 0.3 g_{rms} (Tested in accordance with IEC 60068-2-64.)

Nonoperating 5 Hz to 500 Hz, 2.4 g_{rms} (Tested in accordance with IEC 60068-2-64. Test profile exceeds the requirements of MIL-PRF-28800F, Class 3.)

Compliance and Certifications

Caution You can impair the protection provided by the PXI-4065 if you use it in a manner not described in this document.

Caution This product is intended for use in industrial locations. As a result, this product may cause interference if used in residential areas. Such use must be avoided unless the user takes special measures to reduce electromagnetic emissions to prevent interference to the reception of radio and television broadcasts.

Safety

This product is designed to meet the requirements of the following electrical equipment safety standards for measurement, control, and laboratory use:

- IEC 61010-1, EN 61010-1
- UL 61010-1, CSA C22.2 No. 61010-1

Note For UL and other safety certifications, refer to the product label or the [Online Product Certification](#) section.

Electromagnetic Compatibility

This product meets the requirements of the following EMC standards for electrical equipment for measurement, control, and laboratory use:

- EN 61326-1 (IEC 61326-1): Class A emissions; Basic immunity
- EN 55011 (CISPR 11): Group 1, Class A emissions
- EN 55022 (CISPR 22): Class A emissions
- EN 55024 (CISPR 24): Immunity
- AS/NZS CISPR 11: Group 1, Class A emissions
- AS/NZS CISPR 22: Class A emissions

- FCC 47 CFR Part 15B: Class A emissions
- ICES-001: Class A emissions

Note In the United States (per FCC 47 CFR), Class A equipment is intended for use in commercial, light-industrial, and heavy-industrial locations. In Europe, Canada, Australia, and New Zealand (per CISPR 11), Class A equipment is intended for use only in heavy-industrial locations.

Note Group 1 equipment (per CISPR 11) is any industrial, scientific, or medical equipment that does not intentionally generate radio frequency energy for the treatment of material or inspection/analysis purposes.

Note For EMC declarations, certifications, and additional information, refer to the [Online Product Certification](#) section.

CE Compliance

This product meets the essential requirements of applicable European Directives, as follows:

- 2014/35/EU; Low-Voltage Directive (safety)
- 2014/30/EU; Electromagnetic Compatibility Directive (EMC)

Online Product Certification

Refer to the product Declaration of Conformity (DoC) for additional regulatory compliance information. To obtain product certifications and the DoC for this product, visit ni.com/certification, search by model number or product line, and click the appropriate link in the Certification column.

Environmental Management

NI is committed to designing and manufacturing products in an environmentally responsible manner. NI recognizes that eliminating certain hazardous substances from our products is beneficial to the environment and to NI customers.

For additional environmental information, refer to the **Minimize Our Environmental Impact** web page at ni.com/environment. This page contains the environmental regulations and directives with which NI complies, as well as other environmental information not included in this document.

Waste Electrical and Electronic Equipment (WEEE)

EU Customers At the end of the product life cycle, all NI products must be disposed of according to local laws and regulations. For more information about how to recycle NI products in your region, visit ni.com/environment/weee.

电子信息产品污染控制管理办法（中国 RoHS）

中国客户 National Instruments 符合中国电子信息产品中限制使用某些有害物质指令(RoHS)。关于 National Instruments 中国 RoHS 合规性信息，请登录 ni.com/environment/rohs_china。(For information about China RoHS compliance, go to ni.com/environment/rohs_china.)

¹ T_{cal} = temperature at which last external calibration was performed. NI factory calibration is 23 °C ± 1 °C.

² Measured on the 10 V range.

³ With offset nulling.

⁴ Relative to external calibration source. DMM must remain powered on.

⁵ T_{cal} is the temperature at which last external calibration was performed. NI factory calibration is $23^{\circ}\text{C} \pm 1^{\circ}\text{C}$.

⁶ Tempco is the temperature coefficient in ppm of range per degree Celsius.

⁷ Add 650 ppm/A of reading for currents above 1.5 A.

⁸ Specifications are for 4-wire measurements. For 2-wire measurements, perform offset nulling or add 200 m Ω to specification. For relative humidity >80%, add 100 ppm/M Ω .

⁹ Relative to external calibration source. DMM must remain powered on.

¹⁰ T_{cal} is the temperature at which last external calibration was performed. NI factory calibration is $23^{\circ}\text{C} \pm 1^{\circ}\text{C}$.

¹¹ 2-wire resistance measurement only.

¹² Can be used to test p-n junctions, LEDs, or zener diodes up to 10 V.

¹³ T_{cal} is the temperature at which last external calibration was performed. NI factory calibration is $23^{\circ}\text{C} \pm 1^{\circ}\text{C}$.

¹⁴ Use the 1 Year specification to calibrate on a 90-day cycle.

¹⁵ Tempco is the temperature coefficient. Tempco values are valid within the device's ambient temperature range.

¹⁶ Applicable for non-sinewave signals up to the rated peak voltage, current, or bandwidth.

¹⁷ T_{cal} = temperature at which last external calibration was performed. NI factory calibration is $23^{\circ}\text{C} \pm 1^{\circ}\text{C}$. For total measurement accuracy, add temperature probe error.

¹⁸ Using simulated reference junction.

19 Includes PXI 2527 with TB 2627 with a typical 0.5 °C CJC error and a typical thermal EMF offset of 2.5 μ V for CJC temperatures between 15 °C and 35 °C. Add an additional 0.5 °C uncertainty when CJC is in the range 0 °C to 15 °C or 35 °C to 50 °C.

20 Tempco = Temperature coefficient, expressed in degrees of measurement uncertainty per degree change in DMM instrument operating temperature.

21 RTD with $R_0 = 100 \Omega$ Pt3851 RTD in a 4-wire configuration, using lowest possible resistance range for each temperature.

22 Tempco is the temperature coefficient, expressed in degrees of measurement uncertainty per degree change in DMM instrument operating temperature.