

MDT0128AIS-SPI	240 x 240	SPI Interface	TFT Module
Specification			
Version: 1		Date: 13/04/2022	
Revision			
1	11/04/2022	First issue	

Display Features			
Display Size	1.28"		
Resolution	240 x 240		
Orientation	Round		
Appearance	RGB		
Logic Voltage	2.8V		
Interface	SPI		
Brightness	400 cd/m ²		
Touchscreen	---		
Module Size	35.60 x 37.74 x 1.56mm		
Operating Temperature	-20°C ~ +70°C		
Pinout	18 way FFC		Box Quantity
Pitch	0.5mm	Weight / Display	
		---	---

* - For full design functionality, please use this specification in conjunction with the GC9A01 specification.(Provided Separately)

Display Accessories	
Part Number	Description

Optional Variants	
Appearances	Voltage



General Specifications

- Size: 1.28 inch
- Dot Matrix: 240 x RGB x 240 (TFT) dots
- Module dimension: 35.60 x 37.74 x 1.56 mm
- Active area: 32.40 x 32.40 mm
- Dot pitch: 0.043 X 0.135 mm
- LCD type: TFT, Normally Black, Transmissive
- Viewing Angle: 80/80/80/80
- TFT Interface: SPI
- Backlight Type: LED ,Normally White
- Driver IC: GC9A01
- With /Without TP: Without TP
- Surface: Anti-Glare

*Color tone slight changed by temperature and driving voltage.



Interface

1. LCM PIN Definition

Pin	Symbol	Function	Remark
1-6	NC	No connection	
7	VLED+	Backlit positive	
8	VLED-	Backlit negative	
9	GND	Ground	
10	CS	Chip select signal	
11	SCL	Serial clock	
12	SDA	Serial data signal	
13	RS	Register select signal	
14	TE	TE signal	
15	RESET	LCD RESET Signal	
16	VCI3.3V	LCD Power supply	
17	NC	No connection	
18	GND	Ground	



Contour Drawing

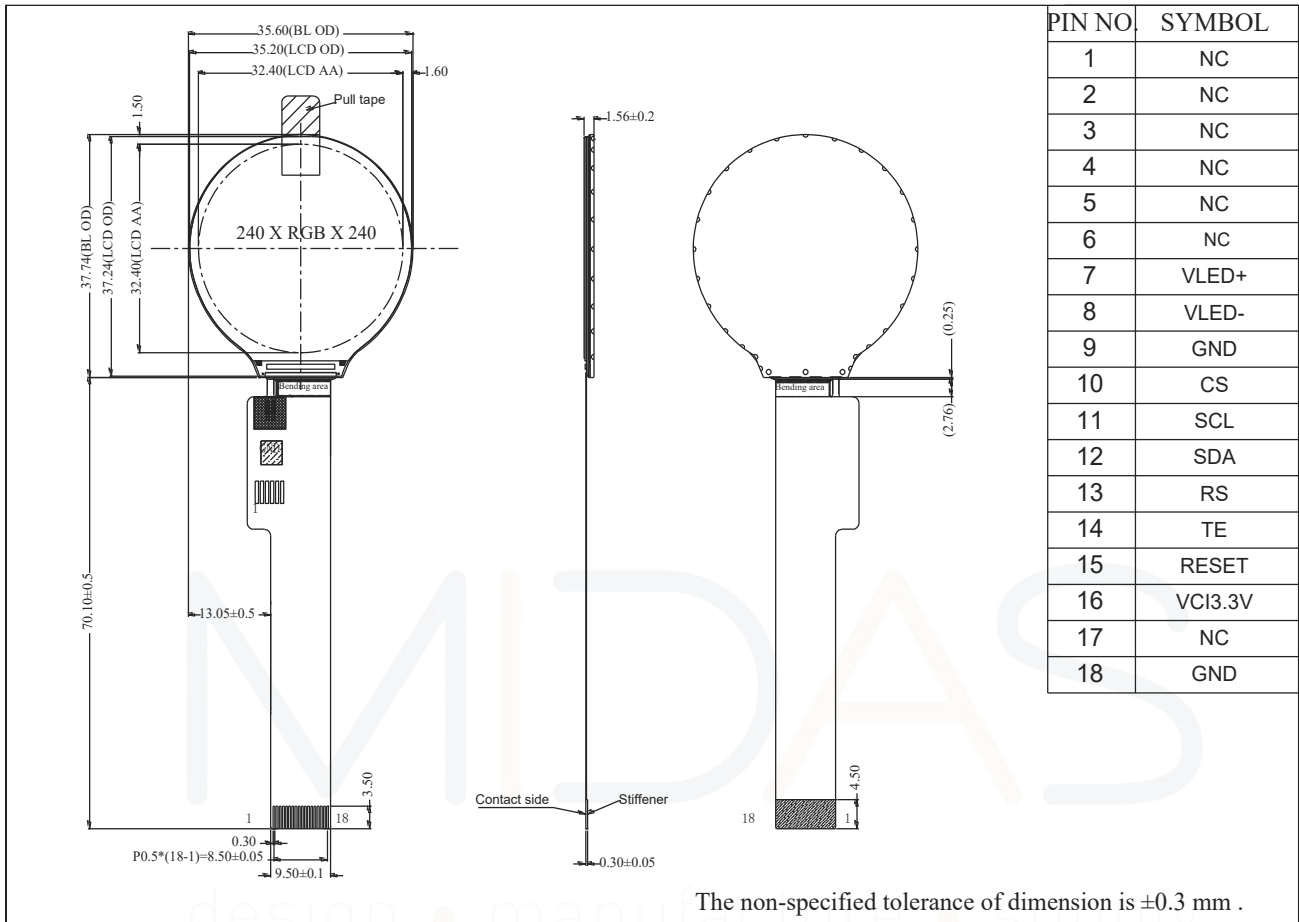

Absolute Maximum Ratings

Item	Symbol	Min	Typ	Max	Unit
Operating Temperature	TOP	-20	—	+70	□
Storage Temperature	TST	-30	—	+80	□

Note: Device is subject to be damaged permanently if stresses beyond those absolute maximum ratings listed above

- Temp. □60□, 90% RH MAX. Temp. >60□, Absolute humidity shall be less than 90% RH at 60□

Electrical Characteristics

1. Operating conditions

Item	Symbol	Conditions	Standard Value			Unit
			Min	Typ	Max	
Power Supply Voltage for Analog	VCI	Ta= +25°C	2.7	2.8	3.3	V
Input High Voltage for LCD	VIH	-	0.8lovcc	-	lovcc	V
Input Low Voltage for LCD	VIL	-	Vss	-	0.2 lovcc	V
Output High Voltage for LCD	VOH	-	0.8lovcc	-	lovcc	V
Output Low Voltage for LCD	VOL	-	Vss	-	0.2 lovcc	V

2. LED driving conditions

Parameter	Symbol	Min.	Typ.	Max.	Unit	Remark
LED current	-	-	40	-	mA	-
LED voltage	VLED+	3.0	3.2	3.4	V	Note 1
LED Life Time	-	-	20,000	-	Hr	Note 2,3,4

Note 1 : There are 1 Groups LED

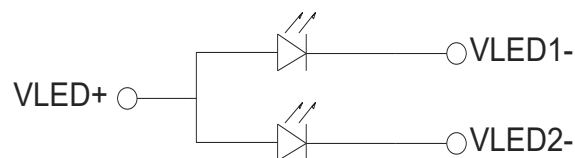

CIRCUIT DIAGRAM

Note 2 : Ta = 25 °C

Note 3 : Brightness to be decreased to 50% of the initial value

Note 4 : The single LED lamp case



Optical Characteristics

Item	Symbol	Condition.	Min	Typ.	Max.	Unit	Remark	
Response time	Tr+ Tf	$\theta=0^\circ$ 、 $\phi=0^\circ$	-	30	-	.ms	Note 3	
Contrast ratio	CR	At optimized viewing angle	-	1000	-	-	Note 4	
Color Chromaticity	White	Wx	$\theta=0^\circ$ 、 $\phi=0^\circ$	0.254	0.304	0.354	-	Note 2,5,6
		Wy		0.277	0.327	0.377	-	
Viewing angle (Gray Scale Inversion Direction)	Hor.	Θ_R	$CR \geq 10$	-	80	-	Deg.	Note 1
		Θ_L		-	80	-		
	Ver.	Φ_T		-	80	-		
		Φ_B		-	80	-		
Brightness	-	-	320	400	-	cd/m ²	Center of display	
Uniformity	(U)	-	75	-	-	%	Note 5	

Ta=25±2°C,

Note 1: Definition of viewing angle range

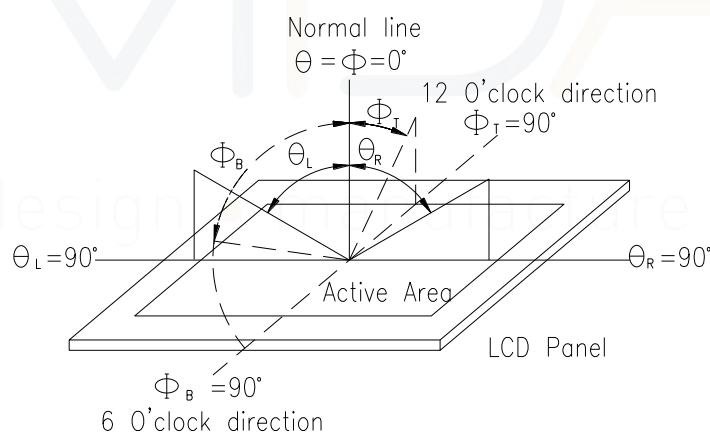

Fig. 7.1. Definition of viewing angle

Note 2: Test equipment setup:

After stabilizing and leaving the panel alone at a driven temperature for 10 minutes, the measurement should be executed. Measurement should be executed in a stable, windless, and dark room. Optical specifications are measured by Topcon BM-7orBM-5 luminance meter 1.0° field of view at a distance of 50cm and normal direction.

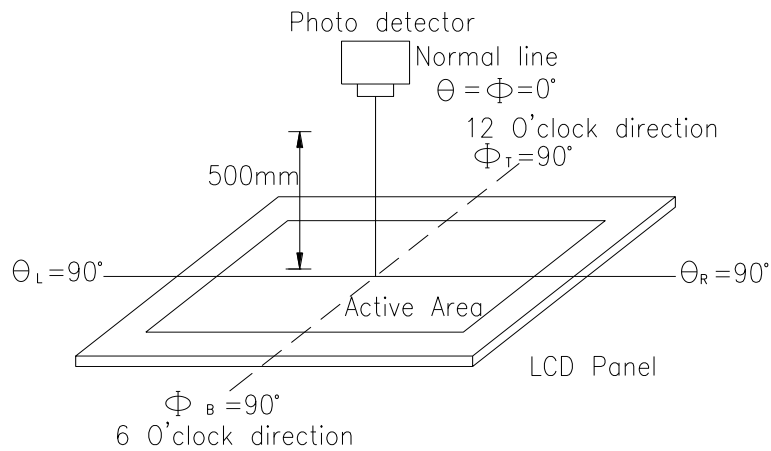
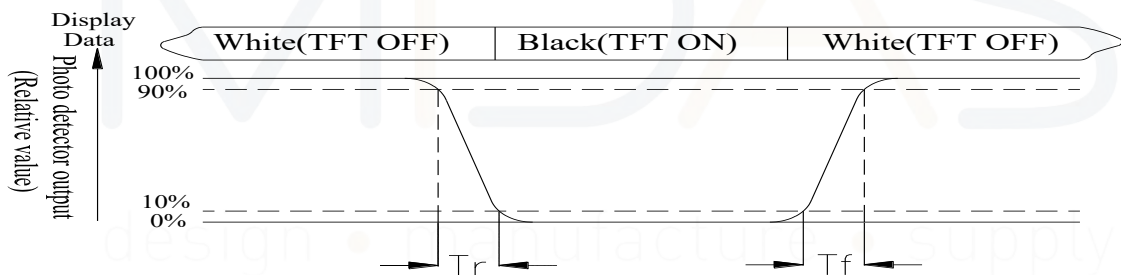

Fig. 7.2. Optical measurement system setup

Note 3: Definition of Response time:

The response time is defined as the LCD optical switching time interval between "White" state and "Black" state. Rise time, T_r , is the time between photo detector output intensity changed from 90% to 10%. And fall time, T_f , is the time between photo detector output intensity changed from 10% to 90%



Note 4: Definition of contrast ratio:

The contrast ratio is defined as the following expression.

$$\text{Contrast ratio (CR)} = \frac{\text{Luminance measured when LCD on the "White" state}}{\text{Luminance measured when LCD on the "Black" state}}$$



Note 5: Definition of Luminance Uniformity

Active area is divided into 9 measuring areas (reference the picture in below). Every measuring point is placed at the center of each measuring area.

$$\text{Luminance Uniformity (U)} = \text{Lmin/Lmax} \times 100\%$$

L = Active area length

W = Active area width

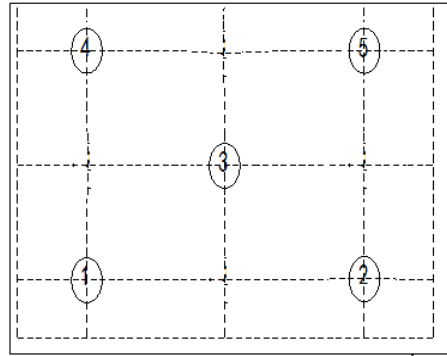

Fig7.3. Definition of uniformity

Note 6: Definition of color chromaticity (CIE 1931)

Color coordinates measured at the center point of LCD

Note 7: Measured at the center area of the panel when all the input terminals of LCD panel are electrically opened.

design • manufacture • supply



Reliability

Content of Reliability Test (Wide temperature, -20□70□)

Environmental Test			
Test Item	Content of Test	Test Condition	Note
High Temperature storage	Endurance test applying the high storage temperature for a long time.	80□ 200hrs	2
Low Temperature storage	Endurance test applying the low storage temperature for a long time.	-30□ 200hrs	1,2
High Temperature Operation	Endurance test applying the electric stress (Voltage & Current) and the thermal stress to the element for a long time.	70□ 200hrs	—
Low Temperature Operation	Endurance test applying the electric stress under low temperature for a long time.	-20□ 200hrs	1
High Temperature/ Humidity Operation	The module should be allowed to stand at 60□,90%RH max	60□,90%RH 96hrs	1,2
Thermal shock resistance	The sample should be allowed stand the following 10 cycles of operation <div style="text-align: center;"> <p style="margin: 0;">-20□ 25□ 70□</p> <p style="margin: 0;">30min 5min 30min</p> <p style="margin: 0;">1 cycle</p> </div>	-20□/70□ 10 cycles	—
Vibration test	Endurance test applying the vibration during transportation and using.	Total fixed amplitude : 1.5mm Vibration Frequency : 10~55Hz One cycle 60 seconds to 3 directions of X,Y,Z for Each 15 minutes	3
Static electricity test	Endurance test applying the electric stress to the terminal.	VS=±600V(contact) ,±800v(air), RS=330Ω CS=150pF 10 times	—

Note1: No dew condensation to be observed.

Note2: The function test shall be conducted after 4 hours storage at the normal Temperature and humidity after remove from the test chamber.

Note3: The packing have to including into the vibration testing.

