

Dot Graphic VFD Module

GU128X8T-K612C5

- 128 x 8 High Brightness Dot Graphic Display
- Single 12V DC Supply
- Large 5x7 ASCII & European Font
- RS232 Asynchronous Serial Interface
- 64 Selectable Multi Drop Addresses
- Transformerless PSU (patent pending)
- Low Profile Construction

The module includes the VFD glass, VF drivers and microcontroller with refresh RAM, character generation, interface logic and patented transformerless DC/DC converter. The RS232 serial interface accepts 9600 or 19200 baud rates with optional parity bit. The module features a low profile design with numerous custom options available including special fonts and commands. Modules can be connected to a multi drop address system.

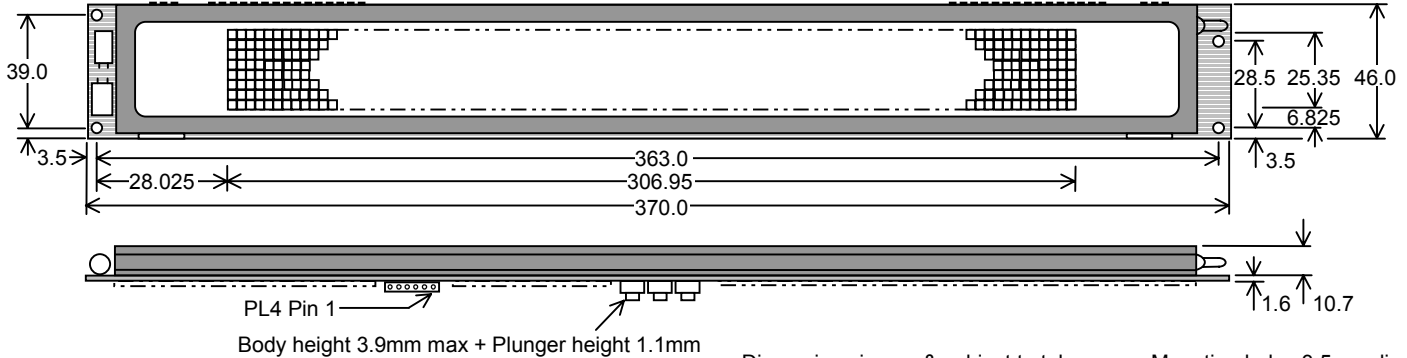

ELECTRICAL SPECIFICATION

Parameter	Symbol	Value	Condition
Supply Voltage	V _{DD}	12.0VDC +/- 10%	GND=0V
Supply Current	I _{DD}	500 mA typ.	V _{DD} =12V
RS232 Input	V _{SIL} / V _{SIH}	-24V max / +24V max	V _{DD} =12V
RS232 Output	V _{SOL} /V _{SOH}	-5VDC min / +5VDC min	V _{DD} =12V

OPTICAL & ENVIRONMENTAL SPECIFICATION

Parameter	Value
Display Area (X x Y mm)	306.95 x 25.35
Dot Size/Pitch (XxY mm)	2.15 x 2.95 / 2.4 x 3.2
Luminance	1000 cd/m ² Typ.
Colour of Illumination	Blue-Green (505nm)
Operating Temperature	-40°C to +85°C
Storage Temperature	-40°C to +85°C
Operating Humidity	20 to 85% RH @ 25°C

Optical filters can provide violet, red, yellow, blue & green output.

SOFTWARE COMMANDS

Hex	Command
10	Software Reset to power on state
11	Write Mode toggles overwrite / scroll
12	Write Direction toggles increment / decrement
13	Display On/Off. Data is retained
14	Display Invert. Toggle negative image
15 + xx	Absolute Column Set from 00H – FFH
16 + xx	Relative Column Set by 00H - FFH
17 + len + data	Graphic Data Write 1 bytes per column, D7 top
18	Clear Character Buffer with 21 ASCII spaces
19 + data	Write to Character Buffer for display effect
1A + effect	Display Effect – fade, wipe, scroll, dissolve
1C + macro + len + data	Store Macro E0H – FFH in EEPROM
1D + delay	Delay Macro – pause for up to 3 seconds
1E + 1E + 1E + FE	Clear Macros from EEPROM
1E + 1E + 1E + FF	Stop Macro if in a loop
1E + 1E + 1E + adr	Address Select 00H – 3FH for active module
20 - DF	Character Write ASCII font.
E0 - FF	Run Macro – execute user defined macro
60 + dh + dl	Send Hexadecimal code instead of binary

The user can send non printable command codes 10H-1EH as hexadecimal. Prefix the code using character 60H. Example: '15'3F = Position column 64.

Handshaking lines DTR/CTS should be linked if not used.
Macro E0 is run at power on.
Received data is re-transmitted from the module TXD output.

Dimensions in mm & subject to tolerances. Mounting holes 3.5mm dia.

CHARACTER SET - 5X7 Font

	00	01	02	03	04	05	06	07	08	09	0A	0B	0C	0D	0E	0F
20	!	"	#	\$	%	&	'	()	*	+	,	-	.	/	
30	0	1	2	3	4	5	6	7	8	9	:	<	=	>	?	
40	a	b	c	d	e	f	g	h	i	j	k	l	m	n	o	
50	p	q	r	s	t	u	v	w	x	y	z	[\]	~	
60	`	a	b	c	d	e	f	g	h	i	j	k	l	m	n	o
70	p	q	r	s	t	u	v	w	x	y	z	{		}	~	
80	E	°	f	l	l	o	r	s	e	n	θ	λ	π	τ	φ	ω
90	Σ	∞	×	÷	°	°	°	°	°	°	°	°	°	°	°	°
A0	À	Á	Â	Ã	Ä	Å	Æ	Ç	È	É	Ê	Ë	Ì	Í	Î	Ï
B0	Ð	Ñ	Ò	Ó	Ô	Õ	Ö	×	Ø	Ù	Ú	Û	Ü	Ý	Þ	
C0	à	á	â	ã	ä	å	æ	ç	è	é	ê	ë	ì	í	î	ï
D0	ð	ñ	ò	ó	ô	õ	ö	÷	ø	ù	ú	û	ü	ý	þ	ÿ

Character 60H is used as a hexadecimal prefix, but can be displayed with a repeat send.

Data is shown in hexadecimal and sent in binary. e.g. FF = 11111111 Bin
Address 'adr' = 00 - 3F. Setting 'adr' to 00 activates all modules.
Column position X = 00 – 7F.

The communication settings and address can be set using the three switches on the rear of the module. Default communication is 9600,n,8,1.
The display effects command allows curtain, dissolve, scroll and fade.
Software and font set are copyright Noritake Itron Corporation 2002

PL4

Pin	Signal	Description
1	VDD	12V Supply
2	RXD	RS232 received data
3	GND	0V supply
4	TXD	RS232 transmitted data
5	DTR	Module Busy if -5V
6	CTS	Host Busy if -5V

CONTACT

Noritake Sales Office Tel Nos
Nagoya Japan: +81 (0)52-561-9867
Canada: +1-416-291-2946
Chicago USA: +1-847-439-9020
Munchen (D): +49 (0)89-3214-290
Itron UK: +44 (0)1493 601144
Rest Europe: +49 (0)61-0520-9220
www.noritake-iron.com

Detailed specification, software commands and interface timing are available on request.
Subject to change without notice.
IUK Doc. No. 03897 Iss.2
24 June 02