

REVISIONS			
REV	DESCRIPTION, ECN, EAR NO.	DATE	APP'D
A	NEW PROPOSAL	JUL19/22	KELVIN

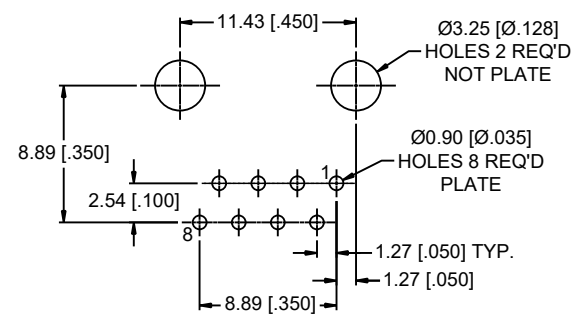
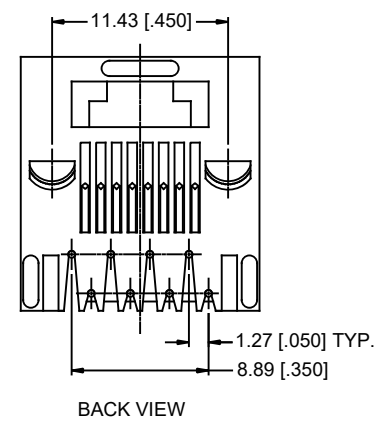
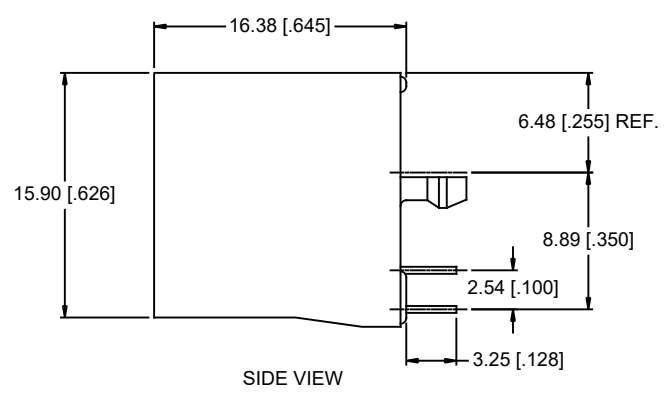
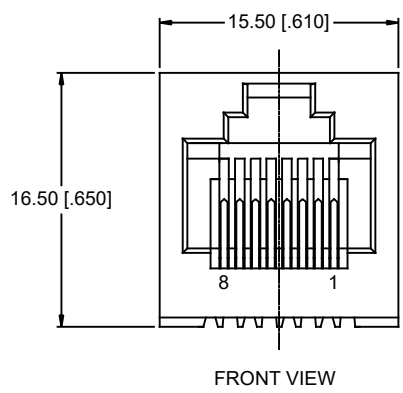

NOTES:

- MATERIALS:**
CONTACTS: PHOSPHOR BRONZE, 0.46MM DIAMETER,
PLATING: GOLD FLASH PLATING,
50µ "[1.27 MICRONS] MIN. NICKEL OVERALL.
HOUSING: ENGINEERING THERMOPLASTIC, FLAMMABILITY RATING UL 94V-0
COLOR - BLACK.
- MECHANICAL:**
MATING FORCE: 5.0 LBS MAXIMUM
- ELECTRICAL:**
CONTACT RESISTANCE: 20 MILLIOHMS MAXIMUM
INSULATION RESISTANCE: 500 MEGOHMS MINIMUM
CUTTENT RATING: 1.5 AMPS
VOLTAGE RATING: 125 VOLTS AC
- ENVIRONMENTAL:**
STORAGE TEMPERATURE: -40°C TO +85°C
- RECOMMENDED SOLDERING TEMPERATURE:**
WAVE SOLDERING PEAKED AT 260°C FOR 5 TO 8 SECONDS.

AMPHENOL PART NUMBER: RJE08-188-001F

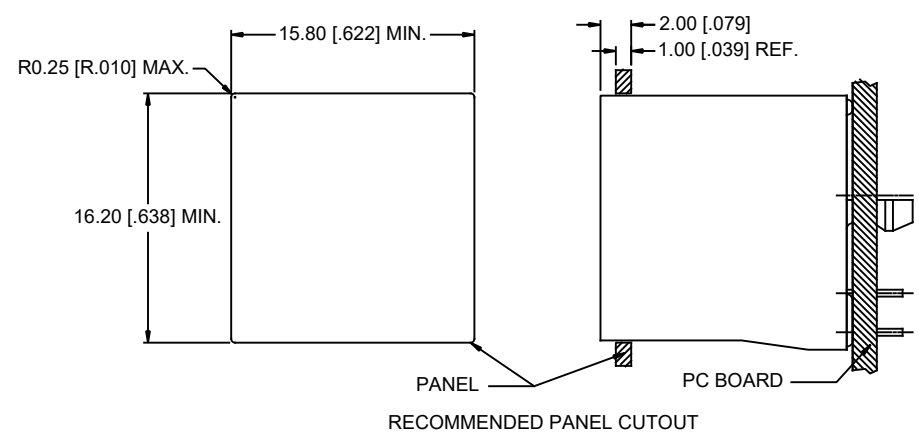

UNLESS SPECIFIED OTHERWISE	DRAWN	RONNIE.C	JUL19/22
PRIMARY UNITS MILLIMETERS	CHECKED	KELVIN.T	JUL19/22
SECONDARY INCHES	M.E. APP'D		
REFERENCE IN PARENTHESES	Q.A. APP'D		
GENERAL TOLERANCES	DWG APP'D		
1 DECIMAL PLACE ±0.35	ENG. REL. NO.		
2 DECIMAL PLACES ±0.25	REF.		
3 DECIMAL PLACES ±0.15			
ANGULAR DEGREES ±2.0°	THIRD ANGLE PROJECTION		
	DO NOT SCALE DRAWING		

Amphenol Canada Corp. Commercial Products	
SINGLE PORT, VERTICAL MODULAR JACK, 8 POSITION, 8 CONTACTS, UNSHIELD -RoHS COMPLIANT	
DWG NO. P-RJE08-188-001F	REV A
CODE ID NO. 03554	DWG SIZE X SCALE N/A SHEET 1 OF 1