

# MCF5275 Integrated Microprocessor Family Hardware Specification

by: Microcontroller Division

The MCF5275 family is a highly integrated implementation of the ColdFire<sup>®</sup> family of reduced instruction set computing (RISC) microprocessors. This document describes pertinent features and functions characteristics of the MCF5275 family. The MCF5275 family includes the MCF5275, MCF5275L, MCF5274 and MCF5274L microprocessors. The differences between these parts are summarized in [Table 1](#). This document is written from the perspective of the MCF5275 and unless otherwise noted, the information applies also to the MCF5275L, MCF5274 and MCF5274L.

The MCF5275 family delivers a new level of performance and integration on the popular version 2 ColdFire core with up to 159 (Dhrystone 2.1) MIPS @ 166MHz. These highly integrated microprocessors build upon the widely used peripheral mix on the popular MCF5272 ColdFire microprocessor (10/100 Mbps Ethernet MAC and USB device) by adding a second 10/100 Mbps Ethernet MAC (MCF5274 and MCF5275) and hardware encryption (MCF5275L and MCF5275).

## Contents

1	MCF5275 Family Configurations . . . . .	2
2	Block Diagram . . . . .	3
3	Features . . . . .	3
4	Signal Descriptions . . . . .	4
5	Design Recommendations . . . . .	9
6	Mechanicals/Pinouts . . . . .	14
7	Ordering Information . . . . .	18
8	Preliminary Electrical Characteristics . . . . .	18
9	Documentation . . . . .	43
10	Revision History . . . . .	43

## MCF5275 Family Configurations

In addition, the MCF5275 family features an enhanced multiply accumulate unit (EMAC), large on-chip memory (64 Kbytes SRAM, 16 Kbytes configurable cache), and a 16-bit DDR SDRAM memory controller.

These devices are ideal for cost-sensitive applications requiring significant control processing for file management, connectivity, data buffering, and user interface, as well as signal processing in a variety of key markets such as security, imaging, networking, gaming, and medical. This leading package of integration and high performance allows fast time to market through easy code reuse and extensive third party tool support.

To locate any published errata or updates for this document, refer to the ColdFire products website at <http://www.freescale.com/coldfire>.

# 1 MCF5275 Family Configurations

Table 1. MCF5275 Family Configurations

Module	MCF5274L	MCF5275L	MCF5274	MCF5275
ColdFire Version 2 Core with EMAC (Enhanced Multiply-Accumulate Unit)	•	•	•	•
System Clock	up to 166 MHz			
Performance (Dhrystone 2.1 MIPS)	up to 159			
Instruction/Data Cache	16 Kbytes (configurable)			
Static RAM (SRAM)	64 Kbytes			
Interrupt Controllers (INTC)	2	2	2	2
Edge Port Module (EPORT)	•	•	•	•
External Interface Module (EIM)	•	•	•	•
4-channel Direct-Memory Access (DMA)	•	•	•	•
DDR SDRAM Controller	•	•	•	•
Fast Ethernet Controller (FEC)	1	1	2	2
Watchdog Timer Module (WDT)	•	•	•	•
4-channel Programmable Interval Timer Module (PIT)	•	•	•	•
32-bit DMA Timers	4	4	4	4
USB	•	•	•	•
QSPI	•	•	•	•
UART(s)	3	3	3	3
I <sup>2</sup> C	•	•	•	•
PWM	4	4	4	4
General Purpose I/O Module (GPIO)	•	•	•	•
CIM = Chip Configuration Module + Reset Controller Module	•	•	•	•
Debug BDM	•	•	•	•
JTAG - IEEE 1149.1 Test Access Port	•	•	•	•
Hardware Encryption	—	•	—	•
Package	196 MAPBGA		256 MAPBGA	

## 2 Block Diagram

The superset device in the MCF5275 family comes in a 256 Mold Array Plastic Ball Grid Array (MAPBGA) package. Figure 1 shows a top-level block diagram of the MCF5275, the superset device.

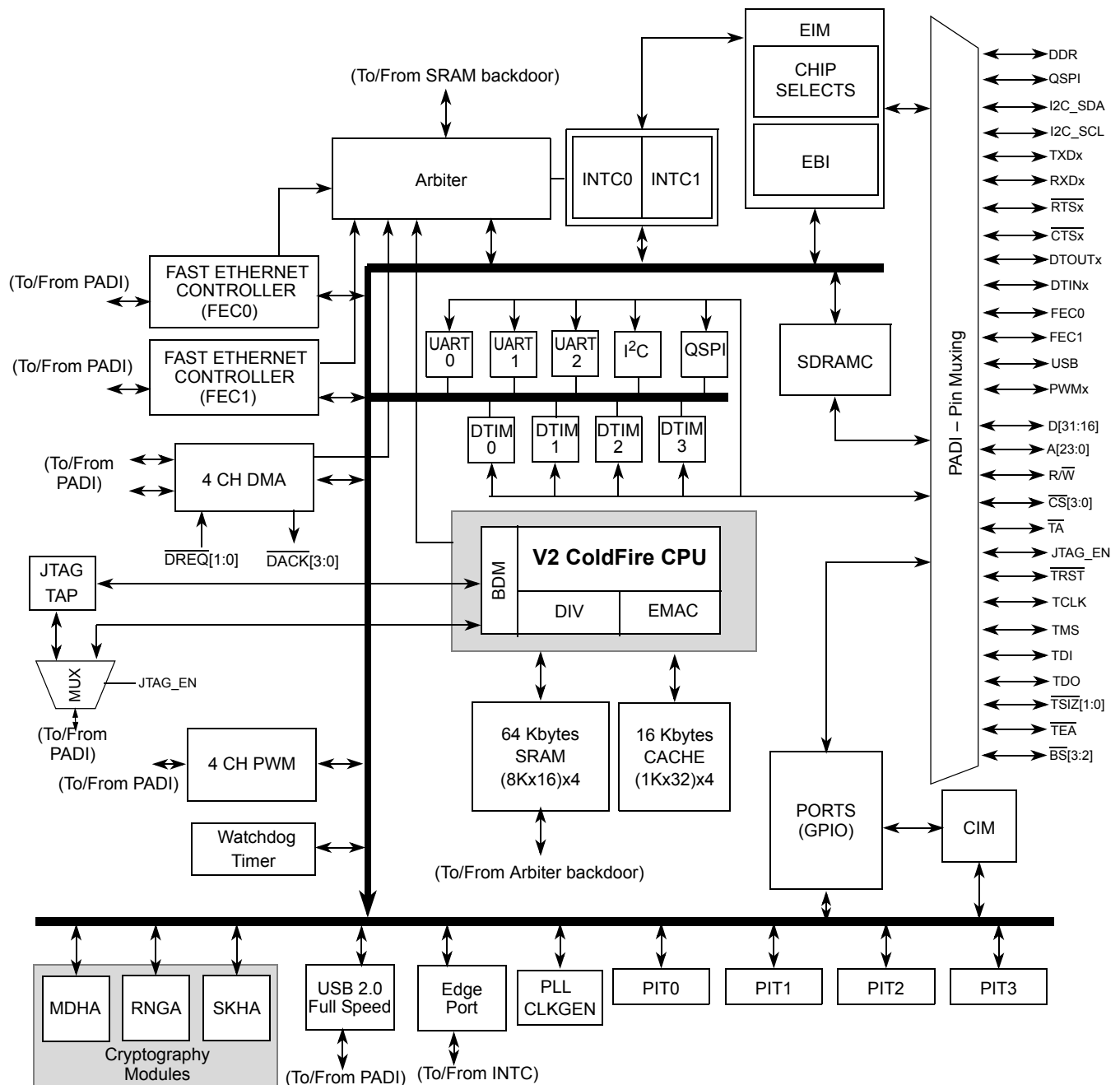

Figure 1. MCF5275 Block Diagram

## 3 Features

For a detailed feature list see the *MCF5275 Reference Manual* (MCF5275RM).

## 4 Signal Descriptions

This section describes signals that connect off chip, including a table of signal properties. For a more detailed discussion of the MCF5275 signals, consult the *MCF5275 Reference Manual* (MCF5275RM).

Table 2 lists the signals for the MCF5275 in functional group order. The “Dir” column is the direction for the primary function of the pin. Refer to Section 6, “Mechanicals/Pinouts,” for package diagrams.

### NOTE

In this table and throughout this document a single signal within a group is designated without square brackets (i.e., A24), while designations for multiple signals within a group use brackets (i.e., A[23:21]) and is meant to include all signals within the two bracketed numbers when these numbers are separated by a colon.

### NOTE

The primary functionality of a pin is not necessarily its default functionality. Pins that are muxed with GPIO will default to their GPIO functionality.

**Table 2. MCF5274 and MCF5275 Signal Information and Muxing**

Signal Name	GPIO	Alternate1	Alternate2	Dir. <sup>1</sup>	MCF5274 MCF5275 256 MAPBGA	MCF5274L MCF5275L 196 MAPBGA
<b>Reset</b>						
$\overline{\text{RESET}}$	—	—	—	I	N15	K12
RSTOUT	—	—	—	O	N14	L12
<b>Clock</b>						
EXTAL	—	—	—	I	L16	M14
XTAL	—	—	—	O	M16	N14
CLKOUT	—	—	—	O	T12	P9
<b>Mode Selection</b>						
CLKMOD[1:0]	—	—	—	I	N13, P13	M11, N11
$\overline{\text{RCON}}$	—	—	—	I	P8	M6
<b>External Memory Interface and Ports</b>						
A[23:21]	PADDR[7:5]	$\overline{\text{CS}}[6:4]$	—	O	A11, B11, C11	A8, B8, C8
A[20:0]	—	—	—	O	A12, B12, C12, A13, B13, C13, A14, B14, C14, B15, C15, B16, C16, D14, D15, E14:16, F14:16	B9, D9, C9, C10, B10, A11, C11, B11, A12, D11, C12, B13, C13, D12, E11, D13, E12, F11, D14, E13, F13

Table 2. MCF5274 and MCF5275 Signal Information and Muxing (continued)

Signal Name	GPIO	Alternate1	Alternate2	Dir. <sup>1</sup>	MCF5274 MCF5275 256 MAPBGA	MCF5274L MCF5275L 196 MAPBGA
D[31:16]	—	—	—	O	M1, N1, N2, N3, P1, P2, R1, R2, P3, R3, T3, N4, P4, R4, T4, N5	J3, L1, K2, K3, M1, L2, L3, L4, K4, J4, M2, N1, N2, M3, M4, N3
$\overline{\text{BS}}[3:2]$	$\overline{\text{PBS}}[3:2]$	$\overline{\text{CAS}}[3:2]$	—	O	M3, R5	K1, L5
$\overline{\text{OE}}$	PBUSCTL[7]	—	—	O	K1	H4
$\overline{\text{TA}}$	PBUSCTL[6]	—	—	I	L13	K14
$\overline{\text{TEA}}$	PBUSCTL[5]	$\overline{\text{DREQ1}}$	—	I	T8	—
R/ $\overline{\text{W}}$	PBUSCTL[4]	—	—	O	P7	L6
TSIZ1	PBUSCTL[3]	DACK1	—	O	D16	B14
TSIZ0	PBUSCTL[2]	DACK0	—	O	G16	E14
$\overline{\text{TS}}$	PBUSCTL[1]	DACK2	—	O	L4	H2
$\overline{\text{TIP}}$	PBUSCTL[0]	$\overline{\text{DREQ0}}$	—	O	P6	—
<b>Chip Selects</b>						
$\overline{\text{CS}}[7:1]$	PCS[7:1]	—	—	O	D10:13, E13, F13, N7	D8, A9, A10, D10, B12, C14, P4
$\overline{\text{CS0}}$	—	—	—	O	R6	N5
<b>DDR SDRAM Controller</b>						
DDR_CLKOUT	—	—	—	O	T7	P6
$\overline{\text{DDR\_CLKOUT}}$	—	—	—	O	T6	P5
$\overline{\text{SD\_CS}}[1:0]$	PSDRAM[7:6]	$\overline{\text{CS}}[3:2]$	—	O	M2, T5	H3, M5
$\overline{\text{SD\_SRAS}}$	PSDRAM[5]	—	—	O	L2	H1
$\overline{\text{SD\_SCAS}}$	PSDRAM[4]	—	—	O	L1	G3
$\overline{\text{SD\_WE}}$	PSDRAM[3]	—	—	O	K2	G4
SD_A10	—	—	—	O	N6	N4
$\overline{\text{SD\_DQS}}[3:2]$	PSDRAM[2:1]	—	—	I/O	M4, P5	J2, P3
SD_CKE	PSDRAM[0]	—	—	O	L3	J1
SD_VREF	—	—	—	I	A15, T2	A13, P2
<b>External Interrupts Port</b>						
$\overline{\text{IRQ}}[7:5]$	PIRQ[7:5]	—	—	I	G13, H16, H15	F14, G13, G14
$\overline{\text{IRQ}}[4]$	PIRQ[4]	$\overline{\text{DREQ2}}$	—	I	H14	H11
$\overline{\text{IRQ}}[3:2]$	PIRQ[3:2]	$\overline{\text{DREQ}}[3:2]$	—	I	J14, J13	H14, H12

Table 2. MCF5274 and MCF5275 Signal Information and Muxing (continued)

Signal Name	GPIO	Alternate1	Alternate2	Dir. <sup>1</sup>	MCF5274 MCF5275 256 MAPBGA	MCF5274L MCF5275L 196 MAPBGA
$\overline{\text{IRQ1}}$	PIRQ[1]	—	—	I	K13	J13
<b>FEC0</b>						
FEC0_MDIO	PFECI2C[5]	I2C_SDA	U2RXD	I/O	A7	A3
FEC0_MDC	PFECI2C[4]	I2C_SCL	U2TXD	O	B7	C5
FEC0_TXCLK	PFEC0H[7]	—	—	I	C3	C1
FEC0_TXEN	PFEC0H[6]	—	—	O	D4	C3
FEC0_TXD[0]	PFEC0H[5]	—	—	O	G4	D2
FEC0_COL	PFEC0H[4]	—	—	I	A6	B4
FEC0_RXCLK	PFEC0H[3]	—	—	I	B6	B3
FEC0_RXDV	PFEC0H[2]	—	—	I	B5	C4
FEC0_RXD[0]	PFEC0H[1]	—	—	I	C6	D5
FEC0_CRS	PFEC0H[0]	—	—	I	C7	A2
FEC0_TXD[3:1]	PFEC0L[7:5]	—	—	O	E3, F3, F4	D1, E3, D3
FEC0_TXER	PFEC0L[4]	—	—	O	D3	C2
FEC0_RXD[3:1]	PFEC0L[3:1]	—	—	I	D5, C5, D6	D4, B1, B2
FEC0_RXER	PFEC0L[0]	—	—	I	C4	E4
<b>FEC1</b>						
FEC1_MDIO	PFECI2C[3]	—	—	I/O	G1	—
FEC1_MDC	PFECI2C[2]	—	—	O	G2	—
FEC1_TXCLK	PFEC1H[7]	—	—	I	C1	—
FEC1_TXEN	PFEC1H[6]	—	—	O	D2	—
FEC1_TXD[0]	PFEC1H[5]	—	—	O	F1	—
FEC1_COL	PFEC1H[4]	—	—	I	A5	—
FEC1_RXCLK	PFEC1H[3]	—	—	I	B4	—
FEC1_RXDV	PFEC1H[2]	—	—	I	A3	—
FEC1_RXD[0]	PFEC1H[1]	—	—	I	B3	—
FEC1_CRS	PFEC1H[0]	—	—	I	A4	—
FEC1_TXD[3:1]	PFEC1L[7:5]	—	—	O	E1, E2, F2	—
FEC1_TXER	PFEC1L[4]	—	—	O	D1	—
FEC1_RXD[3:1]	PFEC1L[3:1]	—	—	I	B1, B2, A2	—
FEC1_RXER	PFEC1L[0]	—	—	I	C2	—

Table 2. MCF5274 and MCF5275 Signal Information and Muxing (continued)

Signal Name	GPIO	Alternate1	Alternate2	Dir. <sup>1</sup>	MCF5274 MCF5275 256 MAPBGA	MCF5274L MCF5275L 196 MAPBGA
<b>I<sup>2</sup>C</b>						
I2C_SDA	PFECI2C[1]	U2RXD	—	I/O	B10	B7
I2C_SCL	PFECI2C[0]	U2TXD	—	I/O	C10	A7
<b>DMA</b>						
DACK[3:0] and $\overline{\text{DREQ}}[3:0]$ do not have a dedicated bond pads. Please refer to the following pins for muxing: PCS3/PWM3 for DACK3, PCS2/PWM2 for DACK2, TSIZ1 for DACK1, TSIZ0 for DACK0, $\overline{\text{IRQ3}}$ for $\overline{\text{DREQ3}}$ , $\overline{\text{IRQ2}}$ and $\overline{\text{TA}}$ for $\overline{\text{DREQ2}}$ , TEA for $\overline{\text{DREQ1}}$ , and $\overline{\text{TIP}}$ for $\overline{\text{DREQ0}}$ .					—	—
<b>QSPI</b>						
QSPI_CS[3:2]	PQSPI[6:5]	PWM[3:2]	DACK[3:2]	O	R13, N12	P10, N9
QSPI_CS1	PQSPI[4]	—	—	O	T14	N10
QSPI_CS0	PQSPI[3]	—	—	O	P12	M9
QSPI_CLK	PQSPI[2]	I2C_SCL	—	O	T15	L11
QSPI_DIN	PQSPI[1]	I2C_SDA	—	I	T13	M10
QSPI_DOUT	PQSPI[0]	—	—	O	R12	L10
<b>UARTs</b>						
U2RXD	PUARTH[3]	—	—	I	T9	—
U2TXD	PUARTH[2]	—	—	O	R9	—
$\overline{\text{U2CTS}}$	PUARTH[1]	PWM1	—	I	P9	—
$\overline{\text{U2RTS}}$	PUARTH[0]	PWM0	—	O	R8	—
U1RXD	PUARTL[7]	—	—	I	A9	A6
U1TXD	PUARTL[6]	—	—	O	B9	D7
$\overline{\text{U1CTS}}$	PUARTL[5]	—	—	I	C9	C7
$\overline{\text{U1RTS}}$	PUARTL[4]	—	—	O	D9	B6
U0RXD	PUARTL[3]	—	—	I	A8	A4
U0TXD	PUARTL[2]	—	—	O	B8	A5
$\overline{\text{U0CTS}}$	PUARTL[1]	—	—	I	C8	C6
$\overline{\text{U0RTS}}$	PUARTL[0]	—	—	O	D7	B5
<b>USB</b>						
USB_SPEED	PUSBH[0]	—	—	I/O	G14	G11
USB_CLK	PUSBL[7]	—	—	I	G15	F12





Table 2. MCF5274 and MCF5275 Signal Information and Muxing (continued)

Signal Name	GPIO	Alternate1	Alternate2	Dir. <sup>1</sup>	MCF5274 MCF5275 256 MAPBGA	MCF5274L MCF5275L 196 MAPBGA
VSSPLL	—	—	—	I	K16	L13
VSS	—	—	—	I	A1, A10, A16, E5, E12, F6, F11, G7:10, H7:10, J1, J7:10, K7:10, L6, L11, M5, N16, R7, T1, T16	F7, F8, G6:9, H6:9, J7, J8
OVDD	—	—	—	I	E6:8, F5, F7, F8, G5, G6, H5, H6, J11, J12, K11, K12, L9, L10, L12, M9:11	E5:7, F5, F6, H10, J9, J10, K8:10
VDD	—	—	—	I	D8, H13, K4, N8	D6, G5, G12, L7
SD_VDD	—	—	—	I	E9:11, F9, F10, F12, G11, G12, H11, H12, J5, J6, K5, K6, L5, L7, L8, M6, M7, M8	E8:10, F9, F10, G10, H5, J5, J6, K5:7

<sup>1</sup> Refers to pin's primary function. All pins which are configurable for GPIO have a pullup enabled in GPIO mode with the exception of PBUSCTL[7], PBUSCTL[4:0], PADDR, PBS, PSDRAM.

<sup>2</sup> If JTAG\_EN is asserted, these pins default to Alternate 1 (JTAG) functionality. The GPIO module is not responsible for assigning these pins.

## 5 Design Recommendations

### 5.1 Layout

- Use a 4-layer printed circuit board with the VDD and GND pins connected directly to the power and ground planes for the MCF5275.
- See application note AN1259 System Design and Layout Techniques for Noise Reduction in MCU-Based Systems.
- Match the PCB layout trace width and routing to match trace length to operating frequency and board impedance. Add termination (series or therein) to the traces to dampen reflections. Increase the PCB impedance (if possible) keeping the trace lengths balanced and short. Then do cross-talk analysis to separate traces with significant parallelism or are otherwise "noisy". Use 6 mils trace and separation. Clocks get extra separation and more precise balancing.

### 5.2 Power Supply

- 33uF, 0.1  $\mu$ F, and 0.01  $\mu$ F across each power supply

## 5.2.1 Supply Voltage Sequencing and Separation Cautions

Figure 2 shows situations in sequencing the I/O  $V_{DD}$  ( $OV_{DD}$ ), SDRAM  $V_{DD}$  ( $SDV_{DD}$ ), PLL  $V_{DD}$  ( $PLLV_{DD}$ ), and Core  $V_{DD}$  ( $V_{DD}$ ).

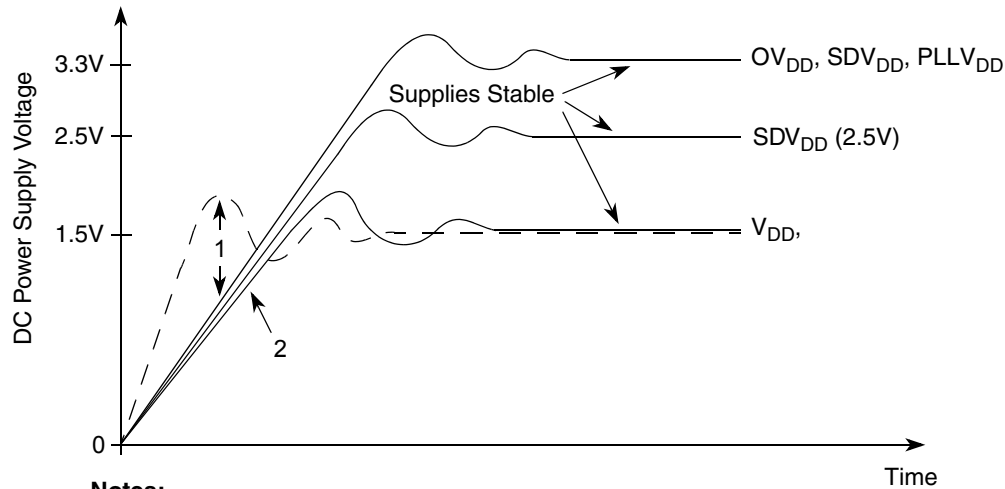

### Notes:

1.  $V_{DD}$  should not exceed  $OV_{DD}$ ,  $SDV_{DD}$  or  $PLLV_{DD}$  by more than 0.4 V at any time, including power-up.
2. Recommended that  $V_{DD}$  should track  $OV_{DD}/SDV_{DD}/PLLV_{DD}$  up to 0.9 V, then separate for completion of ramps.
3. Input voltage must not be greater than the supply voltage ( $OV_{DD}$ ,  $SDV_{DD}$ ,  $V_{DD}$ , or  $PLLV_{DD}$ ) by more than 0.5 V at any time, including during power-up.
4. Use 1 ms or slower rise time for all supplies.

**Figure 2. Supply Voltage Sequencing and Separation Cautions**

The relationship between  $SDV_{DD}$  and  $OV_{DD}$  is non-critical during power-up and power-down sequences.  $SDV_{DD}$  (2.5V or 3.3V) and  $OV_{DD}$  are specified relative to  $V_{DD}$ .

### 5.2.1.1 Power Up Sequence

If  $OV_{DD}/SDV_{DD}$  are powered up with  $V_{DD}$  at 0 V, then the sense circuits in the I/O pads cause all pad output drivers connected to the  $OV_{DD}/SDV_{DD}$  to be in a high impedance state. There is no limit on how long after  $OV_{DD}/SDV_{DD}$  powers up before  $V_{DD}$  must be powered up.  $V_{DD}$  should not lead the  $OV_{DD}$ ,  $SDV_{DD}$ , or  $PLLV_{DD}$  by more than 0.4 V during power ramp-up or high current will be in the internal ESD protection diodes. The rise times on the power supplies should be slower than 1  $\mu$ s to avoid turning on the internal ESD protection clamp diodes.

The recommended power up sequence is as follows:

1. Use 1  $\mu$ s or slower rise time for all supplies.
2.  $V_{DD}/PLLV_{DD}$  and  $OV_{DD}/SDV_{DD}$  should track up to 0.9 V, then separate for the completion of ramps with  $OV_{DD}/SDV_{DD}$  going to the higher external voltages. One way to accomplish this is to use a low drop-out voltage regulator.

### 5.2.1.2 Power Down Sequence

If  $V_{DD}$  is powered down first, then sense circuits in the I/O pads cause all output drivers to be in a high impedance state. There is no limit on how long after  $V_{DD}$  powers down before  $OV_{DD}$ ,  $SDV_{DD}$ , or  $PLL_{DD}$  must power down.  $V_{DD}$  should not lag  $OV_{DD}$ ,  $SDV_{DD}$ , or  $PLL_{DD}$  going low by more than 0.4 V during power down or undesired high current will be in the ESD protection diodes. There are no requirements for the fall times of the power supplies.

The recommended power down sequence is as follows:

1. Drop  $V_{DD}$  to 0 V.
2. Drop  $OV_{DD}/SDV_{DD}/PLL_{DD}$  supplies.

## 5.3 Decoupling

- Place the decoupling capacitors as close to the pins as possible, but they can be outside the footprint of the package.
- 0.1  $\mu$ F and 0.01  $\mu$ F at each supply input

## 5.4 Buffering

- Use bus buffers on all data/address lines for all off-board accesses and for all on-board accesses when excessive loading is expected. See electricals.

## 5.5 Pull-up Recommendations

- Use external pull-up resistors on unused inputs. See pin table.

## 5.6 Clocking Recommendations

- Use a multi-layer board with a separate ground plane.
- Place the crystal and all other associated components as close to the EXTAL and XTAL (oscillator pins) as possible.
- Do not run a high frequency trace around crystal circuit.
- Ensure that the ground for the bypass capacitors is connected to a solid ground trace.
- Tie the ground trace to the ground pin nearest EXTAL and XTAL. This prevents large loop currents in the vicinity of the crystal.
- Tie the ground pin to the most solid ground in the system.
- Do not connect the trace that connects the oscillator and the ground plane to any other circuit element. This tends to make the oscillator unstable.
- Tie XTAL to ground when an external oscillator is clocking the device.

## 5.7 Interface Recommendations

### 5.7.1 DDR SDRAM Controller

#### 5.7.1.1 SDRAM Controller Signals in Synchronous Mode

Table 3 shows the behavior of SDRAM signals in synchronous mode.

**Table 3. Synchronous DRAM Signal Connections**

Signal	Description
SD_SRAS	Synchronous row address strobe. Indicates a valid SDRAM row address is present and can be latched by the SDRAM. SD_SRAS should be connected to the corresponding SDRAM SD_SRAS. Do not confuse SD_SRAS with the DRAM controller's SDRAM_CS[1:0], which should not be interfaced to the SDRAM SD_SRAS signals.
SD_SCAS	Synchronous column address strobe. Indicates a valid column address is present and can be latched by the SDRAM. SD_SCAS should be connected to the corresponding signal labeled SD_SCAS on the SDRAM.
SD_WE	DRAM read/write. Asserted for write operations and negated for read operations.
SD_CS[1:0]	Row address strobe. Select each memory block of SDRAMs connected to the MCF5275. One SDRAM_CS signal selects one SDRAM block and connects to the corresponding CS signals.
SD_CKE	Synchronous DRAM clock enable. Connected directly to the CKE (clock enable) signal of SDRAMs. Enables and disables the clock internal to SDRAM. When CKE is low, memory can enter a power-down mode where operations are suspended or they can enter self-refresh mode. SD_CKE functionality is controlled by DCR[COC]. For designs using external multiplexing, setting COC allows SD_CKE to provide command-bit functionality.
BS[3:2]	Column address strobe. For synchronous operation, BS[3:2] function as byte enables to the SDRAMs. They connect to the DQM signals (or mask qualifiers) of the SDRAMs.
DDR_CLKOUT	Bus clock output. Connects to the CLK input of SDRAMs.

#### 5.7.1.2 Address Multiplexing

See the SDRAM controller module chapter in the *MCF5275 Reference Manual* for details on address multiplexing.

### 5.7.2 Ethernet PHY Transceiver Connection

The FEC supports an MII interface for 10/100 Mbps Ethernet and a seven-wire serial interface for 10 Mbps Ethernet. The interface mode is selected by R\_CNTRL[MII\_MODE]. In MII mode, the 802.3 standard defines and the FEC module supports 18 signals. These are shown in Table 4.

**Table 4. MII Mode**

Signal Description	MCF5275 Pin
Transmit clock	FEC <sub>n</sub> _TXCLK
Transmit enable	FEC <sub>n</sub> _TXEN
Transmit data	FEC <sub>n</sub> _TXD[3:0]
Transmit error	FEC <sub>n</sub> _TXER

Table 4. MII Mode (continued)

Signal Description	MCF5275 Pin
Collision	FEC <sub>n</sub> _COL
Carrier sense	FEC <sub>n</sub> _CRS
Receive clock	FEC <sub>n</sub> _RXCLK
Receive enable	FEC <sub>n</sub> _RXDV
Receive data	FEC <sub>n</sub> _RXD[3:0]
Receive error	FEC <sub>n</sub> _RXER
Management channel clock	FEC <sub>n</sub> _MDC
Management channel serial data	FEC <sub>n</sub> _MDIO

The serial mode interface operates in what is generally referred to as AMD mode. The MCF5275 configuration for seven-wire serial mode connections to the external transceiver are shown in Table 5.

Table 5. Seven-Wire Mode Configuration

Signal Description	MCF5275 Pin
Transmit clock	FEC <sub>n</sub> _TXCLK
Transmit enable	FEC <sub>n</sub> _TXEN
Transmit data	FEC <sub>n</sub> _TXD[0]
Collision	FEC <sub>n</sub> _COL
Receive clock	FEC <sub>n</sub> _RXCLK
Receive enable	FEC <sub>n</sub> _RXDV
Receive data	FEC <sub>n</sub> _RXD[0]
Unused, configure as PB14	FEC <sub>n</sub> _RXER
Unused input, tie to ground	FEC <sub>n</sub> _CRS
Unused, configure as PB[13:11]	FEC <sub>n</sub> _RXD[3:1]
Unused output, ignore	FEC <sub>n</sub> _TXER
Unused, configure as PB[10:8]	FEC <sub>n</sub> _TXD[3:1]
Unused, configure as PB15	FEC <sub>n</sub> _MDC
Input after reset, connect to ground	FEC <sub>n</sub> _MDIO

Refer to the M5275EVB evaluation board user's manual for an example of how to connect an external PHY. Schematics for this board are accessible at the MCF5275 site by navigating to: <http://www.freescale.com/coldfire>.

### 5.7.3 BDM

Use the BDM interface as shown in the M5275EVB evaluation board user's manual. The schematics for this board are accessible at the MCF5275 site by navigating to: <http://www.freescale.com/coldfire>.

# 6 Mechanicals/Pinouts

## 6.1 256 MAPBGA Pinout

Figure 3 is a consolidated MCF5274/75 pinout for the 256 MAPBGA package. Table 2 lists the signals by group and shows which signals are muxed and bonded on each of the device packages.

	1	2	3	4	5	6	7	8	9	10	11	12	13	14	15	16	
A	VSS	FEC1_RXD1	FEC1_RXDV	FEC1_CRS	FEC1_COL	FEC0_COL	FEC0_MDIO	U0RXD	U1RXD	VSS	A23	A20	A17	A14	SD_VREF	VSS	A
B	FEC1_RXD3	FEC1_RXD2	FEC1_RXD0	FEC1_RXCLK	FEC0_RXDV	FEC0_RXCLK	FEC0_MDC	U0TXD	U1TXD	I2C_SDA	A22	A19	A16	A13	A11	A9	B
C	FEC1_TXCLK	FEC1_RXER	FEC0_TXCLK	FEC0_RXER	FEC0_RXD2	FEC0_RXD0	FEC0_CRS	$\overline{U0CTS}$	$\overline{U1CTS}$	I2C_SCL	A21	A18	A15	A12	A10	A8	C
D	FEC1_TXER	FEC1_TXEN	FEC0_TXER	FEC0_TXEN	FEC0_RXD3	FEC0_RXD1	$\overline{U0RTS}$	VDD	$\overline{U1RTS}$	$\overline{CS7}$	$\overline{CS6}$	$\overline{CS5}$	$\overline{CS4}$	A7	A6	TSIZ1	D
E	FEC1_TXD3	FEC1_TXD2	FEC0_TXD3	NC	VSS	OVDD	OVDD	OVDD	SD_VDD	SD_VDD	SD_VDD	VSS	$\overline{CS3}$	A5	A4	A3	E
F	FEC1_TXD0	FEC1_TXD1	FEC0_TXD2	FEC0_TXD1	OVDD	VSS	OVDD	OVDD	SD_VDD	SD_VDD	VSS	SD_VDD	$\overline{CS2}$	A2	A1	A0	F
G	FEC1_MDIO	FEC1_MDC	DT0OUT	FEC0_TXD0	OVDD	OVDD	VSS	VSS	VSS	VSS	SD_VDD	SD_VDD	$\overline{IRQ7}$	USB_SPEED	USB_CLK	TSIZ0	G
H	DT1IN	DT1OUT	DT0IN	NC	OVDD	OVDD	VSS	VSS	VSS	VSS	SD_VDD	SD_VDD	VDD	$\overline{IRQ4}$	$\overline{IRQ5}$	$\overline{IRQ6}$	H
J	VSS	DT2IN	DT2OUT	DT3IN	SD_VDD	SD_VDD	VSS	VSS	VSS	VSS	OVDD	OVDD	$\overline{IRQ2}$	$\overline{IRQ3}$	USB_RP	USB_RN	J
K	$\overline{OE}$	$\overline{SD_WE}$	DT3OUT	VDD	SD_VDD	SD_VDD	VSS	VSS	VSS	VSS	OVDD	OVDD	$\overline{IRQ1}$	USB_TN	USB_TP	VSSPLL	K
L	$\overline{SD_SCAS}$	$\overline{SD_SRAS}$	SD_CKE	$\overline{TS}$	SD_VDD	VSS	SD_VDD	SD_VDD	OVDD	OVDD	VSS	OVDD	$\overline{TA}$	USB_TXEN	USB_RXD	EXTAL	L
M	D31	$\overline{SD_CS1}$	$\overline{BS3}$	SD_DQS3	VSS	SD_VDD	SD_VDD	SD_VDD	OVDD	OVDD	OVDD	NC	USB_SUSP	PLL_TEST	VDDPLL	XTAL	M
N	D30	D29	D28	D20	D16	SD_A10	$\overline{CS1}$	VDD	TEST	DDATA2	DDATA0	QSPL_CS2	CLK_MOD1	$\overline{RSTOUT}$	$\overline{RESET}$	VSS	N
P	D27	D26	D23	D19	SD_DQS2	$\overline{TIP}$	R/W	$\overline{RCON}$	$\overline{U2CTS}$	DDATA3	DDATA1	QSPL_CS0	CLK_MOD0	$\overline{TRST}/\overline{DSCLK}$	TDO/DSO	TCLK/PSTCLK	P
R	D25	D24	D22	D18	$\overline{BS2}$	$\overline{CS0}$	VSS	$\overline{U2RTS}$	U2TXD	PST2	PST0	QSPL_DOUT	QSPL_CS3	JTAG_EN	TMS/BKPT	TDI/DSI	R
T	VSS	SD_VREF	D21	D17	$\overline{SD_CS0}$	$\overline{DDR_CLK_OUT}$	DDR_CLK_OUT	$\overline{TEA}$	U2RXD	PST3	PST1	CLKOUT	QSPL_DIN	QSPL_CS1	QSPL_CLK	VSS	T
	1	2	3	4	5	6	7	8	9	10	11	12	13	14	15	16	

Figure 3. MCF5274 and MCF5275 Pinout (256 MAPBGA)

## 6.2 Package Dimensions - 256 MAPBGA

Figure 6 shows MCF5275 256 MAPBGA package dimensions.

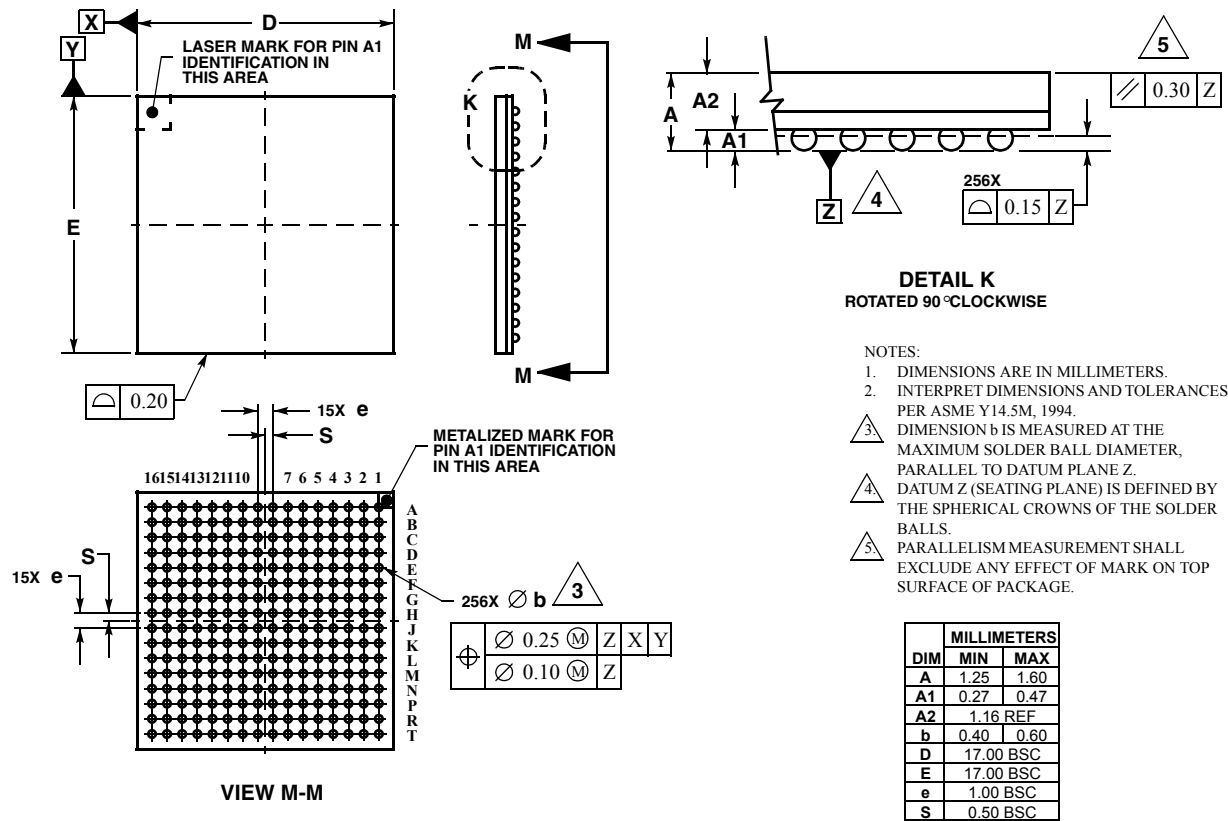

Figure 4. 256 MAPBGA Package Dimensions

## 6.3 196 MAPBGA Pinout

Figure 5 is a consolidated MCF5274L/75L pinout for the 196 MAPBGA package. Table 2 lists the signals by group and shows which signals are muxed and bonded on each of the device packages.

	1	2	3	4	5	6	7	8	9	10	11	12	13	14	
A	NC	FEC0_CRS	FEC0_MDIO	U0RXD	U0TXD	U1RXD	I2C_SCL	A23	$\overline{CS6}$	$\overline{CS5}$	A15	A12	SD_VREF	NC	A
B	FEC0_RXD2	FEC0_RXD1	FEC0_RXCLK	FEC0_COL	$\overline{U0RTS}$	$\overline{U1RTS}$	I2C_SDA	A22	A20	A16	A13	$\overline{CS3}$	A9	TSIZ1	B
C	FEC0_TXCLK	FEC0_TXER	FEC0_TXEN	FEC0_RXDV	FEC0_MDC	$\overline{U0CTS}$	$\overline{U1CTS}$	A21	A18	A17	A14	A10	A8	$\overline{CS2}$	C
D	FEC0_TXD3	FEC0_TXD0	FEC0_TXD1	FEC0_RXD3	FEC0_RXD0	VDD	U1TXD	$\overline{CS7}$	A19	$\overline{CS4}$	A11	A7	A5	A2	D
E	DT0IN	DT0OUT	FEC0_TXD2	FEC0_RXER	OVDD	OVDD	OVDD	SD_VDD2	SD_VDD2	SD_VDD2	A6	A4	A1	TSIZ0	E
F	DT1IN	DT1OUT	DT2IN	DT2OUT	OVDD	OVDD	VSS	VSS	SD_VDD2	SD_VDD2	A3	USB_CLK	A0	$\overline{IRQ7}$	F
G	DT3OUT	DT3IN	$\overline{SD_CAS}$	$\overline{SD_WE}$	VDD	VSS	VSS	VSS	VSS	SD_VDD2	USB_SPEED	VDD	$\overline{IRQ6}$	$\overline{IRQ5}$	G
H	$\overline{SD_SRAS}$	$\overline{TS}$	$\overline{SD_CS1}$	$\overline{OE}$	SD_VDD1	VSS	VSS	VSS	VSS	OVDD	$\overline{IRQ4}$	$\overline{IRQ2}$	USB_RN	$\overline{IRQ3}$	H
J	SD_CKE	SD_DQS3	D31	D22	SD_VDD1	SD_VDD1	VSS	VSS	OVDD	OVDD	USB_RP	USB_TP	$\overline{IRQ1}$	USB_TN	J
K	$\overline{BS3}$	D29	D28	D23	SD_VDD1	SD_VDD1	SD_VDD1	OVDD	OVDD	OVDD	TDO/DSO	$\overline{RESET}$	USB_TXEN	$\overline{TA}$	K
L	D30	D26	D25	D24	$\overline{BS2}$	R $\overline{W}$	VDD	PST2	DDATA0	QSPI_DOUT	QSPI_CLK	$\overline{RSTOUT}$	VSSPLL	USB_RXD	L
M	D27	D21	D18	D17	$\overline{SD_CS0}$	$\overline{RCON}$	DDATA3	PST1	QSPI_CS0	QSPI_DIN	CLKMOD1	TDI/DSI	VDDPLL	EXTAL	M
N	D20	D19	D16	SD_A10	$\overline{CS0}$	TEST	DDATA2	PST0	QSPI_CS2	QSPI_CS1	CLKMOD0	TMS/BKPT	USB_SUSP	XTAL	N
P	NC	SD_VREF	SD_DQS2	$\overline{CS1}$	$\overline{DDR_CLK}$ OUT	DDR_CLK OUT	PST3	DDATA1	CLKOUT	QSPI_CS3	JTAG_EN	TCLK/PST CLK	$\overline{TRST/DSC}$ LK	NC	P
	1	2	3	4	5	6	7	8	9	10	11	12	13	14	

Figure 5. MCF5274L and MCF5275L Pinout (196 MAPBGA)



## 6.4 Package Dimensions - 196 MAPBGA

Figure 6 shows MCF5275 196 MAPBGA package dimensions.

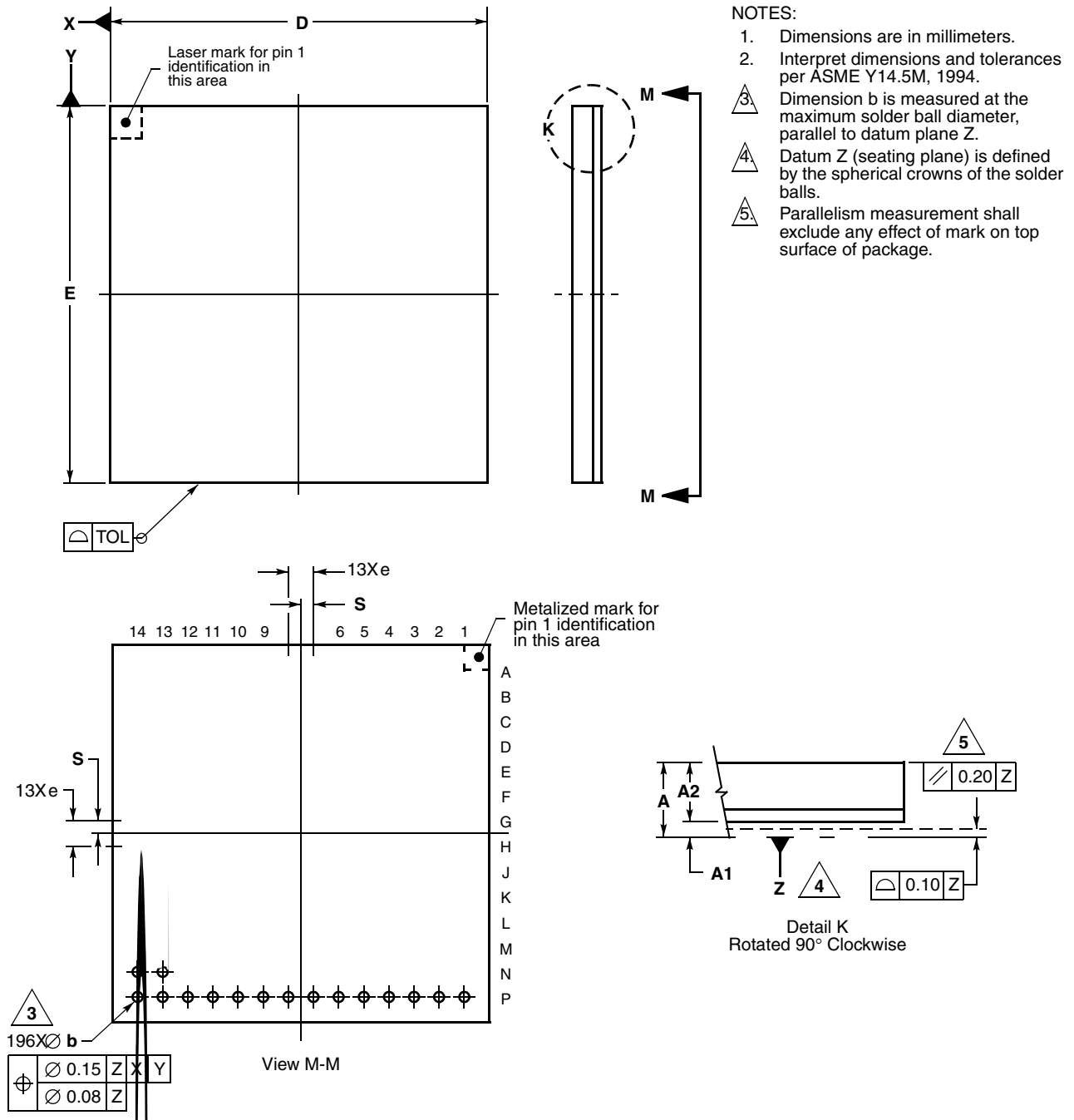

Figure 6. 196 MAPBGA Package Dimensions

## 7 Ordering Information

Table 6. Orderable Part Numbers

Freescle Part Number	Description	Package	Speed	Temperature
MCF5274LVM166	MCF5274L RISC Microprocessor	196 MAPBGA	166 MHz	0° to +70° C
MCF5274LCVM166				-40° to +85° C
MCF5274VM166	MCF5274 RISC Microprocessor	256 MAPBGA	166 MHz	0° to +70° C
MCF5274CVM166				-40° to +85° C
MCF5275LCVM166	MCF5275L RISC Microprocessor	196 MAPBGA	166 MHz	-40° to +85° C
MCF5275CVM166	MCF5275 RISC Microprocessor	256 MAPBGA	166 MHz	-40° to +85° C

## 8 Preliminary Electrical Characteristics

This appendix contains electrical specification tables and reference timing diagrams for the MCF5275 microcontroller unit. This section contains detailed information on power considerations, DC/AC electrical characteristics, and AC timing specifications of MCF5275.

The electrical specifications are preliminary and are from previous designs or design simulations. These specifications may not be fully tested or guaranteed at this early stage of the product life cycle. However, for production silicon, these specifications will be met. Finalized specifications will be published after complete characterization and device qualifications have been completed.

### NOTE

The parameters specified in this appendix supersede any values found in the module specifications.

### 8.1 Maximum Ratings

Table 7. Absolute Maximum Ratings<sup>1, 2</sup>

Rating	Symbol	Value	Unit
Core Supply Voltage	$V_{DD}$	-0.5 to +2.0	V
I/O Pad Supply Voltage (3.3V)	$OV_{DD}$	-0.3 to +4.0	V
Memory Interface SSTL 2.5V Pad Supply Voltage	$SDV_{DD}$	-0.3 to +2.8	V
Memory Interface SSTL 3.3V Pad Supply Voltage	$SDV_{DD}$	-0.3 to +4.0	V
PLL Supply Voltage	$V_{DDPLL}$	-0.3 to +4.0	V
Digital Input Voltage <sup>3</sup>	$V_{IN}$	-0.3 to +4.0	V
EXTAL pin voltage	$V_{EXTAL}$	0 to 3.3	V

Table 7. Absolute Maximum Ratings<sup>1, 2</sup> (continued)

Rating	Symbol	Value	Unit
XTAL pin voltage	$V_{XTAL}$	0 to 3.3	V
Instantaneous Maximum Current Single pin limit (applies to all pins) <sup>4, 5</sup>	$I_D$	25	mA
Operating Temperature Range (Packaged)	$T_A$ ( $T_L - T_H$ )	- 40 to 85	°C
Storage Temperature Range	$T_{stg}$	- 65 to 150	°C

<sup>1</sup> Functional operating conditions are given in DC Electrical Specifications. Absolute Maximum Ratings are stress ratings only, and functional operation at the maxima is not guaranteed. Stress beyond those listed may affect device reliability or cause permanent damage to the device.

<sup>2</sup> This device contains circuitry protecting against damage due to high static voltage or electrical fields; however, it is advised that normal precautions be taken to avoid application of any voltages higher than maximum-rated voltages to this high-impedance circuit. Reliability of operation is enhanced if unused inputs are tied to an appropriate logic voltage level (e.g.,  $V_{SS}$  or  $O V_{DD}$ ).

<sup>3</sup> Input must be current limited to the value specified. To determine the value of the required current-limiting resistor, calculate resistance values for positive and negative clamp voltages, then use the larger of the two values.

<sup>4</sup> All functional non-supply pins are internally clamped to  $V_{SS}$  and  $O V_{DD}$ .

<sup>5</sup> Power supply must maintain regulation within operating  $O V_{DD}$  range during instantaneous and operating maximum current conditions. If positive injection current ( $V_{in} > O V_{DD}$ ) is greater than  $I_{DD}$ , the injection current may flow out of  $O V_{DD}$  and could result in external power supply going out of regulation. Ensure the external  $O V_{DD}$  load shunts current greater than maximum injection current. This is the greatest risk when the MCU is not consuming power (ex; no clock). Power supply must maintain regulation within operating  $V_{DD}$  range during instantaneous and operating maximum current conditions.

## 8.2 Thermal Characteristics

Table 8 lists thermal resistance values

Table 8. Thermal characteristics

Characteristic		Symbol	256MBGA	196MBGA	Unit
Junction to ambient, natural convection	Four layer board (2s2p)	$\theta_{JMA}$	26 <sup>1,2</sup>	32 <sup>1,2</sup>	°C/W
Junction to ambient (@200 ft/min)	Four layer board (2s2p)	$\theta_{JMA}$	23 <sup>1,2</sup>	29 <sup>1,2</sup>	°C/W
Junction to board		$\theta_{JB}$	15 <sup>3</sup>	20 <sup>3</sup>	°C/W
Junction to case		$\theta_{JC}$	10 <sup>4</sup>	10 <sup>4</sup>	°C/W
Junction to top of package	Natural convection	$\Psi_{jt}$	2 <sup>1,5</sup>	2 <sup>1,5</sup>	°C/W
Maximum operating junction temperature		$T_j$	105	105	°C

<sup>1</sup>  $\theta_{JMA}$  and  $\Psi_{jt}$  parameters are simulated in conformance with EIA/JESD Standard 51-2 for natural convection. Freescale recommends the use of  $\theta_{JMA}$  and power dissipation specifications in the system design to prevent device junction temperatures from exceeding the rated specification. System designers should be aware that device junction temperatures can be significantly influenced by board layout and surrounding devices. Conformance to the device junction temperature specification can be verified by physical measurement in the customer's system using the  $\Psi_{jt}$  parameter, the device power dissipation, and the method described in EIA/JESD Standard 51-2.

<sup>2</sup> Per JEDEC JESD51-6 with the board horizontal.

<sup>3</sup> Thermal resistance between the die and the printed circuit board in conformance with JEDEC JESD51-8. Board temperature is measured on the top surface of the board near the package.

## Preliminary Electrical Characteristics

- 4 Thermal resistance between the die and the case top surface as measured by the cold plate method (MIL SPEC-883 Method 1012.1).
- 5 Thermal characterization parameter indicating the temperature difference between package top and the junction temperature per JEDEC JESD51-2. When Greek letters are not available, the thermal characterization parameter is written in conformance with Psi-JT.

The average chip-junction temperature ( $T_J$ ) in °C can be obtained from:

$$T_J = T_A + (P_D \times \Theta_{JMA}) \quad (1)$$

Where:

$T_A$	= Ambient Temperature, °C
$\Theta_{JMA}$	= Package Thermal Resistance, Junction-to-Ambient, °C/W
$P_D$	= $P_{INT} + P_{I/O}$
$P_{INT}$	= $I_{DD} \times V_{DD}$ , Watts - Chip Internal Power
$P_{I/O}$	= Power Dissipation on Input and Output Pins — User Determined

For most applications  $P_{I/O} < P_{INT}$  and can be ignored. An approximate relationship between  $P_D$  and  $T_J$  (if  $P_{I/O}$  is neglected) is:

$$P_D = K \div (T_J + 273^\circ\text{C}) \quad (2)$$

Solving equations 1 and 2 for K gives:

$$K = P_D \times (T_A + 273^\circ\text{C}) + \Theta_{JMA} \times P_D^2 \quad (3)$$

where K is a constant pertaining to the particular part. K can be determined from equation (3) by measuring  $P_D$  (at equilibrium) for a known  $T_A$ . Using this value of K, the values of  $P_D$  and  $T_J$  can be obtained by solving equations (1) and (2) iteratively for any value of  $T_A$ .

## 8.3 ESD Protection

**Table 9. ESD Protection Characteristics<sup>1, 2</sup>**

Characteristics	Symbol	Value	Units
ESD Target for Human Body Model	HBM	2000	V
ESD Target for Machine Model	MM	200	V
HBM Circuit Description	$R_{series}$	1500	$\Omega$
	C	100	pF
MM Circuit Description	$R_{series}$	0	$\Omega$
	C	200	pF
Number of pulses per pin (HBM) positive pulses negative pulses	—	1	—
	—	1	—
Number of pulses per pin (MM) positive pulses negative pulses	—	3	—
	—	3	—
Interval of Pulses	—	1	sec

<sup>1</sup> All ESD testing is in conformity with CDF-AEC-Q100 Stress Test Qualification for Automotive Grade Integrated Circuits.

- <sup>2</sup> A device is defined as a failure if after exposure to ESD pulses the device no longer meets the device specification requirements. Complete DC parametric and functional testing is performed per applicable device specification at room temperature followed by hot temperature, unless specified otherwise in the device specification.

## 8.4 DC Electrical Specifications

Table 10. DC Electrical Specifications<sup>1</sup>

Characteristic	Symbol	Min	Max	Unit
Core Supply Voltage	$V_{DD}$	1.4	1.6	V
I/O Pad Supply Voltage	$OV_{DD}$	3.0	3.6	V
SSTL I/O Pad Supply Voltage	$SDV_{DD}$	2.3	2.7	V
SSTL I/O Pad Supply Voltage	$SDV_{DD}$	3.0	3.6	V
SSTL Memory pads reference voltage (SD $V_{DD} = 2.5V$ )	$V_{REF}$	$0.5 SD V_{DD}$	— <sup>2</sup>	V
SSTL Memory pads reference voltage (SD $V_{DD} = 3.3V$ )	$V_{REF}$	$0.45 SD V_{DD}$	— <sup>2</sup>	V
Input High Voltage 3.3V I/O Pads	$V_{IH}$	$0.7 \times OV_{DD}$	$OV_{DD} + 0.3$	V
Input Low Voltage 3.3V I/O Pads	$V_{IL}$	$V_{SS} - 0.3$	$0.35 \times OV_{DD}$	V
Output High Voltage 3.3V I/O Pads $I_{OH} = -2.0 \text{ mA}$	$V_{OH}$	$OV_{DD} - 0.5$	—	V
Output Low Voltage 3.3V I/O Pads $I_{OL} = 2.0 \text{ mA}$	$V_{OL}$	—	0.5	V
Input Hysteresis 3.3V I/O Pads	$V_{HYS}$	$0.06 \times V_{DD}$	—	mV
Input High Voltage SSTL 3.3V/2.5V <sup>3</sup>	$V_{IH}$	$V_{REF} + 0.3$	$SDV_{DD} + 0.3$	V
Input Low Voltage SSTL 3.3V/2.5V <sup>3</sup>	$V_{IL}$	$V_{SS} - 0.3$	$V_{REF} - 0.3$	V
Output High Voltage SSTL 3.3V/2.5V <sup>4</sup> $I_{OH} = -5.0 \text{ mA}$	$V_{OH}$	$SDV_{DD} - 0.25V$	—	V
Output Low Voltage SSTL 3.3V/2.5V <sup>4</sup> $I_{OL} = 5.0 \text{ mA}$	$V_{OL}$	—	0.35	V
Input Leakage Current $V_{in} = V_{DD}$ or $V_{SS}$ , Input-only pins	$I_{in}$	-1.0	1.0	$\mu\text{A}$
High Impedance (Off-State) Leakage Current $V_{in} = V_{DD}$ or $V_{SS}$ , All input/output and output pins	$I_{OZ}$	-1.0	1.0	$\mu\text{A}$
Weak Internal Pull Up Device Current, tested at $V_{IL}$ Max. <sup>5</sup>	$I_{APU}$	-10	-130	$\mu\text{A}$
Input Capacitance <sup>6</sup> All input-only pins All input/output (three-state) pins	$C_{in}$	— —	7 7	pF

**Table 10. DC Electrical Specifications<sup>1</sup> (continued)**

Characteristic	Symbol	Min	Max	Unit
Load Capacitance <sup>7</sup> Low Drive Strength High Drive Strength	$C_L$		25 50	pF
Core Operating Supply Current <sup>8</sup> Master Mode WAIT DOZE STOP	$I_{DD}$	— — — —	175 15 10 100	mA mA mA $\mu$ A
I/O Pad Operating Supply Current Master Mode Low Power Modes	$OI_{DD}$	— —	250 250	mA $\mu$ A
DC Injection Current <sup>3, 9, 10, 11</sup> $V_{NEGCLAMP} = V_{SS} - 0.3$ V, $V_{POSCLAMP} = V_{DD} + 0.3$ Single Pin Limit Total MCU Limit, Includes sum of all stressed pins	$I_{IC}$	-1.0 -10	1.0 10	mA

- <sup>1</sup> Refer to Table 11 for additional PLL specifications.
- <sup>2</sup>  $V_{REF}$  is specified as a nominal value only instead of a range, so no maximum value is listed.
- <sup>3</sup> This specification is guaranteed by design and is not 100% tested.
- <sup>4</sup> The actual  $V_{OH}$  and  $V_{OL}$  values for SSTL pads are dependent on the termination and drive strength used. The specifications numbers assume no parallel termination.
- <sup>5</sup> Refer to the MCF5274 signals chapter for pins having weak internal pull-up devices.
- <sup>6</sup> This parameter is characterized before qualification rather than 100% tested.
- <sup>7</sup> pF load ratings are based on DC loading and are provided as an indication of driver strength. High speed interfaces require transmission line analysis to determine proper drive strength and termination.
- <sup>8</sup> Current measured at maximum system clock frequency, all modules active, and default drive strength with matching load.
- <sup>9</sup> All functional non-supply pins are internally clamped to  $V_{SS}$  and their respective  $V_{DD}$ .
- <sup>10</sup> Input must be current limited to the value specified. To determine the value of the required current-limiting resistor, calculate resistance values for positive and negative clamp voltages, then use the larger of the two values.
- <sup>11</sup> Power supply must maintain regulation within operating  $V_{DD}$  range during instantaneous and operating maximum current conditions. If positive injection current ( $V_{in} > V_{DD}$ ) is greater than  $I_{DD}$ , the injection current may flow out of  $V_{DD}$  and could result in external power supply going out of regulation. Ensure the external  $V_{DD}$  load shunts current greater than maximum injection current. This is the greatest risk when the MCU is not consuming power. Examples are: if no system clock is present, or if clock rate is very low which would reduce overall power consumption. Also, at power-up, system clock is not present during the power-up sequence until the PLL has attained lock.

## 8.5 Oscillator and Phase Lock Loop (PLL/MRFB) Electrical Specifications

Table 11. PLL Electrical Specifications<sup>1</sup>

Characteristic	Symbol	Min	Max	Unit
PLL Reference Frequency Range				MHz
Crystal reference	$f_{ref\_crystal}$	8	25	
External reference	$f_{ref\_ext}$	8	25	
1:1 Mode (NOTE: $f_{sys/2} = 2 \times f_{ref\_1:1}$ )	$f_{ref\_1:1}$	24	83	
Core frequency	$f_{core}$		166	MHz
CLKOUT Frequency <sup>2</sup>				
External reference		0	83	MHz
On-Chip PLL Frequency	$f_{sys/2}$	$f_{ref} / 32$	83	MHz
Loss of Reference Frequency <sup>3, 5</sup>	$f_{LOR}$	100	1000	kHz
Self Clocked Mode Frequency <sup>4, 5</sup>	$f_{SCM}$	TBD	TBD	MHz
Crystal Start-up Time <sup>5, 6</sup>	$t_{cst}$	—	10	ms
EXTAL Input High Voltage	$V_{IHEXT}$			V
Crystal Mode	$V_{IHEXT}$	TBD	TBD	
All other modes (Dual Controller (1:1), Bypass, External)		TBD	TBD	
EXTAL Input Low Voltage	$V_{ILEXT}$			V
Crystal Mode	$V_{ILEXT}$	TBD	TBD	
All other modes (Dual Controller (1:1), Bypass, External)		TBD	TBD	
XTAL Output High Voltage	$V_{OH}$			V
$I_{OH} = 1.0$ mA		TBD	—	
XTAL Output Low Voltage	$V_{OL}$			V
$I_{OL} = 1.0$ mA		—	TBD	
XTAL Load Capacitance <sup>7</sup>		5	30	pF
PLL Lock Time <sup>8</sup>	$t_{ipll}$	—	750	$\mu$ s
Power-up To Lock Time <sup>6, 9</sup>	$t_{iplk}$			
With Crystal Reference		—	11	ms
Without Crystal Reference <sup>10</sup>		—	750	$\mu$ s
1:1 Mode Clock Skew (between CLKOUT and EXTAL) <sup>11</sup>	$t_{skew}$	-1	1	ns
Duty Cycle of reference <sup>5</sup>	$t_{dc}$	40	60	% $f_{sys/2}$
Frequency un-LOCK Range	$f_{UL}$	-3.8	4.1	% $f_{sys/2}$
Frequency LOCK Range	$f_{LCK}$	-1.7	2.0	% $f_{sys/2}$
CLKOUT Period Jitter, <sup>5, 6, 9, 12, 13</sup> Measured at $f_{sys/2}$ Max	$C_{jitter}$			
Peak-to-peak Jitter (Clock edge to clock edge)		—	5	% $f_{sys/2}$
Long Term Jitter (Averaged over 2 ms interval)		—	.01	
Frequency Modulation Range Limit <sup>14, 15</sup>	$C_{mod}$	0.8	2.2	% $f_{sys/2}$
( $f_{sys/2}$ Max must not be exceeded)				
ICO Frequency. $f_{ico} = f_{ref} * 2 * (MFD+2)$ <sup>16</sup>	$f_{ico}$	48	83	MHz

<sup>1</sup> All values given are initial design targets and subject to change.

<sup>2</sup> All internal registers retain data at 0 Hz.

<sup>3</sup> "Loss of Reference Frequency" is the reference frequency detected internally, which transitions the PLL into self clocked mode.

## Preliminary Electrical Characteristics

- 4 Self clocked mode frequency is the frequency that the PLL operates at when the reference frequency falls below  $f_{LOR}$  with default MFD/RFD settings.
- 5 This parameter is guaranteed by characterization before qualification rather than 100% tested.
- 6 Proper PC board layout procedures must be followed to achieve specifications.
- 7 Load capacitance determined from crystal manufacturer specifications and includes circuit board parasitics.
- 8 This specification applies to the period required for the PLL to relock after changing the MFD frequency control bits in the synthesizer control register (SYNCR).
- 9 Assuming a reference is available at power up, lock time is measured from the time  $V_{DD}$  and  $V_{DDPLL}$  are valid to  $\overline{RSTOUT}$  negating. If the crystal oscillator is being used as the reference for the PLL, then the crystal start up time must be added to the PLL lock time to determine the total start-up time.
- 10  $t_{pll} = (64 * 4 * 5 + 5 * \tau) * T_{ref}$ , where  $T_{ref} = 1/F_{ref\_crystal} = 1/F_{ref\_ext} = 1/F_{ref\_1:1}$ , and  $\tau = 1.57 \times 10^{-6} * 2(MFD + 2)$
- 11 PLL is operating in 1:1 PLL mode.
- 12 Jitter is the average deviation from the programmed frequency measured over the specified interval at maximum  $f_{sys/2}$ . Measurements are made with the device powered by filtered supplies and clocked by a stable external clock signal. Noise injected into the PLL circuitry via  $V_{DDPLL}$  and  $V_{SSPLL}$  and variation in crystal oscillator frequency increase the jitter percentage for a given interval.
- 13 Based on slow system clock of 33MHz maximum frequency.
- 14 Modulation percentage applies over an interval of 10 $\mu$ s, or equivalently the modulation rate is 100KHz.
- 15 Modulation rate selected must not result in  $f_{sys/2}$  value greater than the  $f_{sys/2}$  maximum specified value. Modulation range determined by hardware design.
- 16  $f_{sys/2} = f_{ico} / (2 * 2^{RFD})$

## 8.6 External Interface Timing Characteristics

Table 12 lists processor bus input timings.

### NOTE

All processor bus timings are synchronous; that is, input setup/hold and output delay with respect to the rising edge of a reference clock. The reference clock is the CLKOUT output.

All other timing relationships can be derived from these values.

**Table 12. Processor Bus Input Timing Specifications**

Name	Characteristic <sup>1</sup>	Symbol	Min	Max	Unit
B0	CLKOUT	$t_{CYC}$	12	—	ns
<b>Control Inputs</b>					
B1a	Control input valid to CLKOUT high <sup>2</sup>	$t_{CVCH}$	9	—	ns
B1b	$\overline{BKPT}$ valid to CLKOUT high <sup>3</sup>	$t_{BKVCH}$	9	—	ns
B2a	CLKOUT high to control inputs invalid <sup>2</sup>	$t_{CHCII}$	0	—	ns
B2b	CLKOUT high to asynchronous control input $\overline{BKPT}$ invalid <sup>3</sup>	$t_{BKNCH}$	0	—	ns
<b>Data Inputs</b>					
B4	Data input (D[31:16]) valid to CLKOUT high	$t_{DIVCH}$	4	—	ns
B5	CLKOUT high to data input (D[31:16]) invalid	$t_{CHDII}$	0	—	ns

<sup>1</sup> Timing specifications have been indicated taking into account the full drive strength for the pads.

<sup>2</sup>  $\overline{TEA}$  and  $\overline{TA}$  pins are being referred to as control inputs.

<sup>3</sup> Refer to figure A-19.



Timings listed in Table 12 are shown in Figure 7.

\* The timings are also valid for inputs sampled on the negative clock edge.

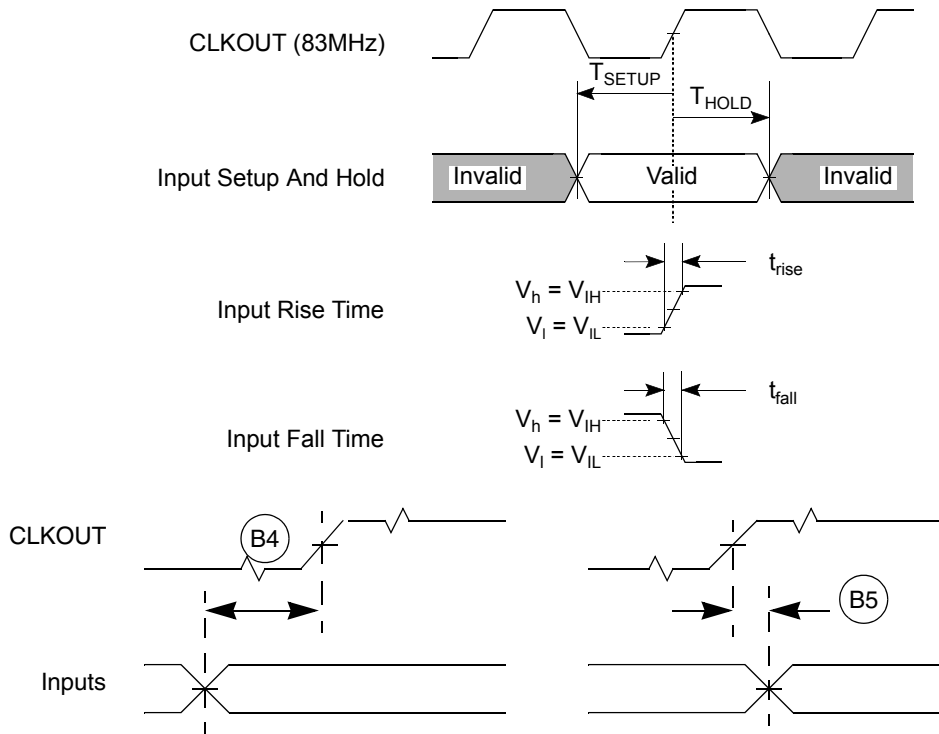

Figure 7. General Input Timing Requirements

## 8.7 Processor Bus Output Timing Specifications

Table 13 lists processor bus output timings.

Table 13. External Bus Output Timing Specifications

Name	Characteristic	Symbol	Min	Max	Unit
<b>Control Outputs</b>					
B6a	CLKOUT high to chip selects ( $\overline{CS}[7:0]$ ) valid <sup>1</sup>	$t_{CHCV}$	—	$0.5t_{CYC} + 5.5$	ns
B6b	CLKOUT high to byte enables ( $\overline{BS}[3:2]$ ) valid <sup>1</sup>	$t_{CHBV}$	—	$0.5t_{CYC} + 5.5$	ns
B6c	CLKOUT high to output enable ( $\overline{OE}$ ) valid <sup>1</sup>	$t_{CHOV}$	—	$0.5t_{CYC} + 5.5$	ns
B7	CLKOUT high to control output ( $\overline{BS}[3:2]$ , $\overline{OE}$ ) invalid	$t_{CHCOI}$	$0.5t_{CYC} + 1.0$	—	ns
B7a	CLKOUT high to chip selects invalid	$t_{CHCI}$	$0.5t_{CYC} + 1.0$	—	ns
<b>Address and Attribute Outputs</b>					
B8	CLKOUT high to address ( $A[23:0]$ ) and control ( $\overline{TS}$ , $TSIZ[1:0]$ , $\overline{TIP}$ , $R/\overline{W}$ ) valid	$t_{CHAV}$	—	9	ns
B9	CLKOUT high to address ( $A[23:0]$ ) and control ( $\overline{TS}$ , $TSIZ[1:0]$ , $\overline{TIP}$ , $R/\overline{W}$ ) invalid	$t_{CHAI}$	1.0	—	ns

**Table 13. External Bus Output Timing Specifications (continued)**

Name	Characteristic	Symbol	Min	Max	Unit
<b>Data Outputs</b>					
B11	CLKOUT high to data output (D[31:16]) valid	t <sub>CHDOV</sub>	—	9	ns
B12	CLKOUT high to data output (D[31:16]) invalid	t <sub>CHDOI</sub>	1.0	—	ns
B13	CLKOUT high to data output (D[31:16]) high impedance	t <sub>CHDOZ</sub>	—	9	ns

<sup>1</sup>  $\overline{CS}$ ,  $\overline{BS}$ , and  $\overline{OE}$  transition after the falling edge of CLKOUT.

Read/write bus timings listed in Table 13 are shown in Figure 8, Figure 9, and Figure 10.



**Figure 8. Read/Write (Internally Terminated) SRAM Bus Timing**

Figure 9 shows a bus cycle terminated by  $\overline{\text{TA}}$  showing timings listed in Table 13.

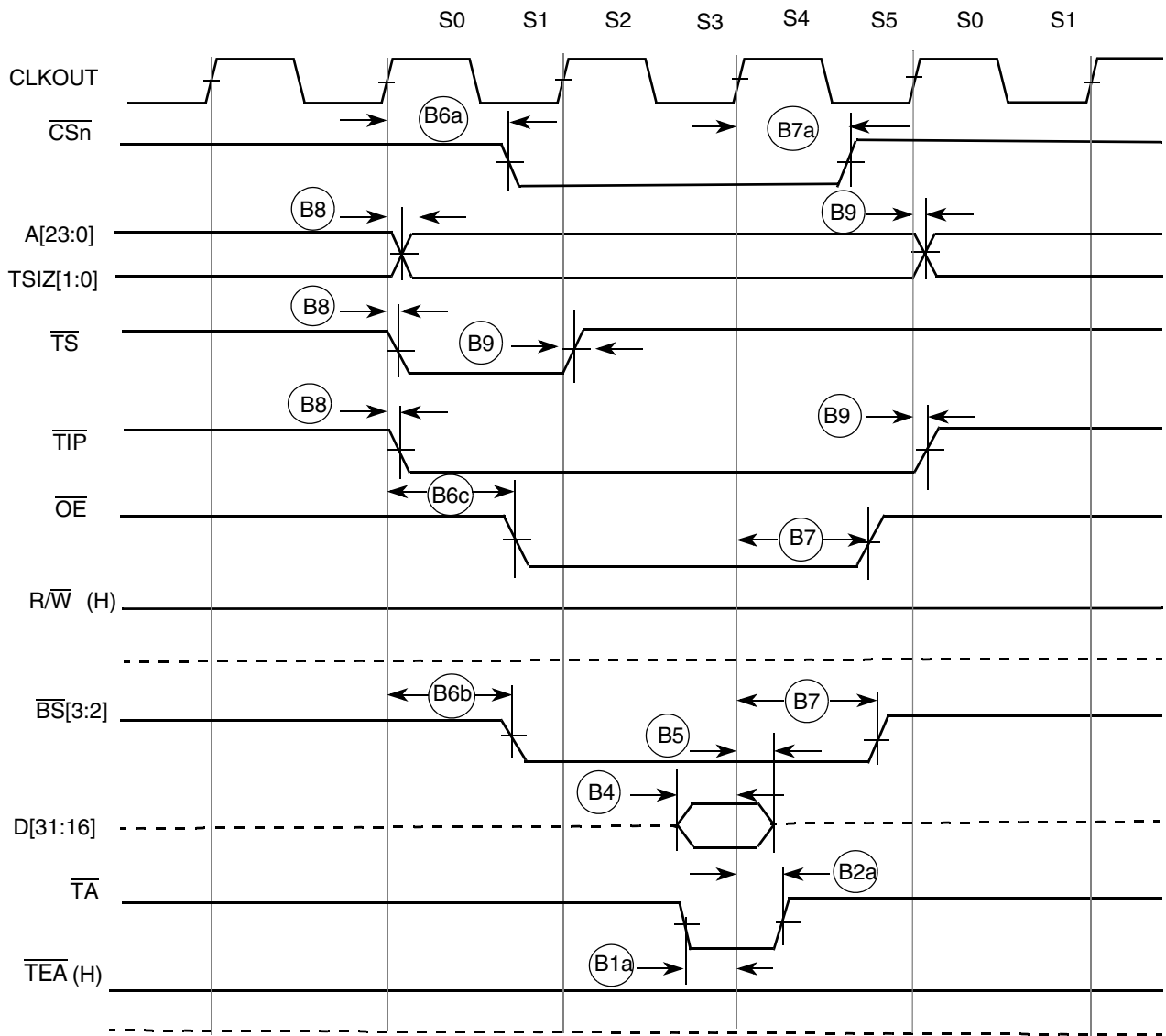

Figure 9. SRAM Read Bus Cycle Terminated by  $\overline{\text{TA}}$



**Preliminary Electrical Characteristics**

## 8.8 DDR SDRAM AC Timing Characteristics

The DDR SDRAM controller uses SSTL2 and I/O drivers. Class I or Class II drive strength is available and is user programmable. DDR Clock timing specifications are given in Table 14 and Figure 11.

**Table 14. DDR Clock Timing Specifications<sup>1</sup>**

Symbol	Characteristic	Min	Max	Unit
$V_{MP}$	Clock output mid-point voltage	1.05	1.45	V
$V_{OUT}$	Clock output voltage level	-0.3	$SDV_{DD} + 0.3$	V
$V_{ID}$	Clock output differential voltage (peak to peak swing)	0.7	$SDV_{DD} + 0.6$	V
$V_{IX}$	Clock crossing point voltage	1.05	1.45	V

<sup>1</sup> SD  $V_{DD}$  is nominally 2.5V.

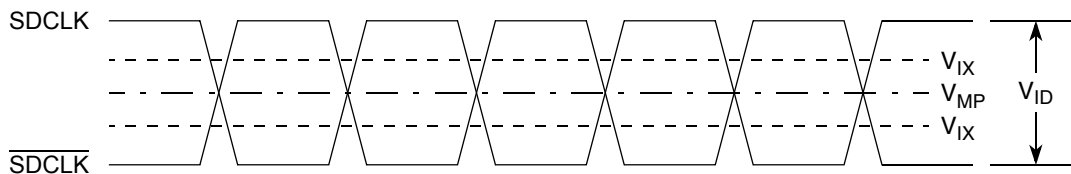

**Figure 11. DDR Clock Timing Diagram**

When using the DDR SDRAM controller the timing numbers in Table 15 must be followed to properly latch or drive data onto the memory bus. All timing numbers are relative to the two DQS byte lanes.

**Table 15. DDR Timing**

NUM	Characteristic <sup>1</sup>	Symbol	Min	Max	Unit
	Frequency of operation <sup>2</sup>		TBD	83	MHz
DD1	Clock Period (DDR_CLKOUT)	$t_{CK}$	12	TBD	ns
DD2	Pulse Width High <sup>3</sup>	$t_{CKH}$	0.45	0.55	$t_{CK}$
DD3	Pulse Width Low <sup>3</sup>	$t_{CKI}$	0.45	0.55	$t_{CK}$
DD4	DDR_CLKOUT high to DDR address, SD_CKE, SD_CS[1:0], SD_SCAS, SD_SRAS, SD_WE valid	$t_{CMV}$	—	$0.5 \times t_{CK} + 1$	ns
DD5	DDR_CLKOUT high to DDR address, SD_CKE, $\overline{SD\_CS}$ , SD_SCAS, SD_SRAS, SD_WE invalid	$t_{CMH}$	2	—	ns
DD6	Write command to first SD_DQS Latching Transition	$t_{DQSS}$	—	1.25	$t_{CK}$
DD7	$\overline{SD\_DQS}$ high to Data and DM valid (write) - setup <sup>4,5</sup>	$t_{QS}$	1.5	—	ns
DD8	$\overline{SD\_DQS}$ high to Data and DM invalid (write) - hold <sup>4</sup>	$t_{QH}$	1	—	ns
DD9	$\overline{SD\_DQS}$ high to Data valid (read) - setup <sup>6</sup>	$t_{IS}$	—	1	ns
DD10	$\overline{SD\_DQS}$ high to Data invalid (read) - hold <sup>7</sup>	$t_{IH}$	$0.25 \times t_{CK} + 1$	—	ns
DD11	$\overline{SD\_DQS}$ falling edge to CLKOUT high - setup	$t_{DSS}$	0.5	—	ns
DD12	$\overline{SD\_DQS}$ falling edge to CLKOUT high - hold	$t_{DSH}$	0.5	—	ns

**Table 15. DDR Timing (continued)**

NUM	Characteristic <sup>1</sup>	Symbol	Min	Max	Unit
DD13	DQS input read preamble width ( $t_{RPRE}$ )	$t_{RPRE}$	0.9	1.1	$t_{CK}$
DD14	DQS input read postamble width ( $t_{RPST}$ )	$t_{RPST}$	0.4	0.6	$t_{CK}$
DD15	DQS output write preamble width ( $t_{WPRE}$ )	$t_{WPRE}$	0.25	—	$t_{CK}$
DD16	DQS output write postamble width ( $t_{WPST}$ )	$t_{WPST}$	0.4	0.6	$t_{CK}$

<sup>1</sup> All timing specifications are based on taking into account, a 25pF load on the SDRAM output pins.

<sup>2</sup> DDR\_CLKOUT operates at half the frequency of the PLLMRFM output and the ColdFire core.

<sup>3</sup>  $t_{CKH} + t_{CKL}$  must be less than or equal to  $t_{CK}$ .

<sup>4</sup> D[31:24] is relative to  $\overline{SD\_DQS3}$  and D[23:16] is relative to  $\overline{SD\_DQS2}$ .

<sup>5</sup> The first data beat is valid before the first rising edge of  $\overline{SD\_DQS}$  and after the  $\overline{SD\_DQS}$  write preamble. The remaining data beats are valid for each subsequent  $\overline{SD\_DQS}$  edge

<sup>6</sup> Data input skew is derived from each  $\overline{SD\_DQS}$  clock edge. It begins with a  $\overline{SD\_DQS}$  transition and ends when the last data line becomes valid. This input skew must include DDR memory output skew and system level board skew (due to routing or other factors).

<sup>7</sup> Data input hold is derived from each  $\overline{SD\_DQS}$  clock edge. It begins with a  $\overline{SD\_DQS}$  transition and ends when the first data line becomes invalid.

Figure 13 shows a DDR SDRAM write cycle.

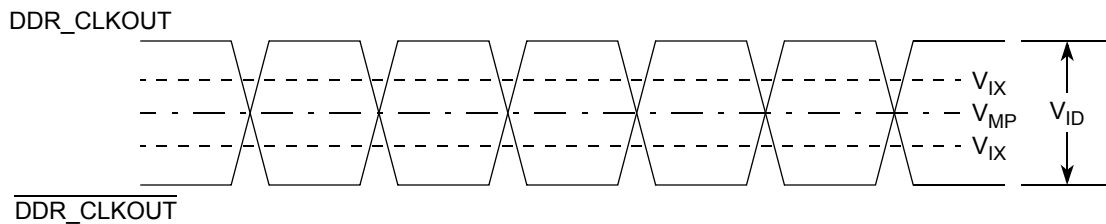

**Figure 12. DDR\_CLKOUT and  $\overline{DDR\_CLKOUT}$  Crossover Timing**

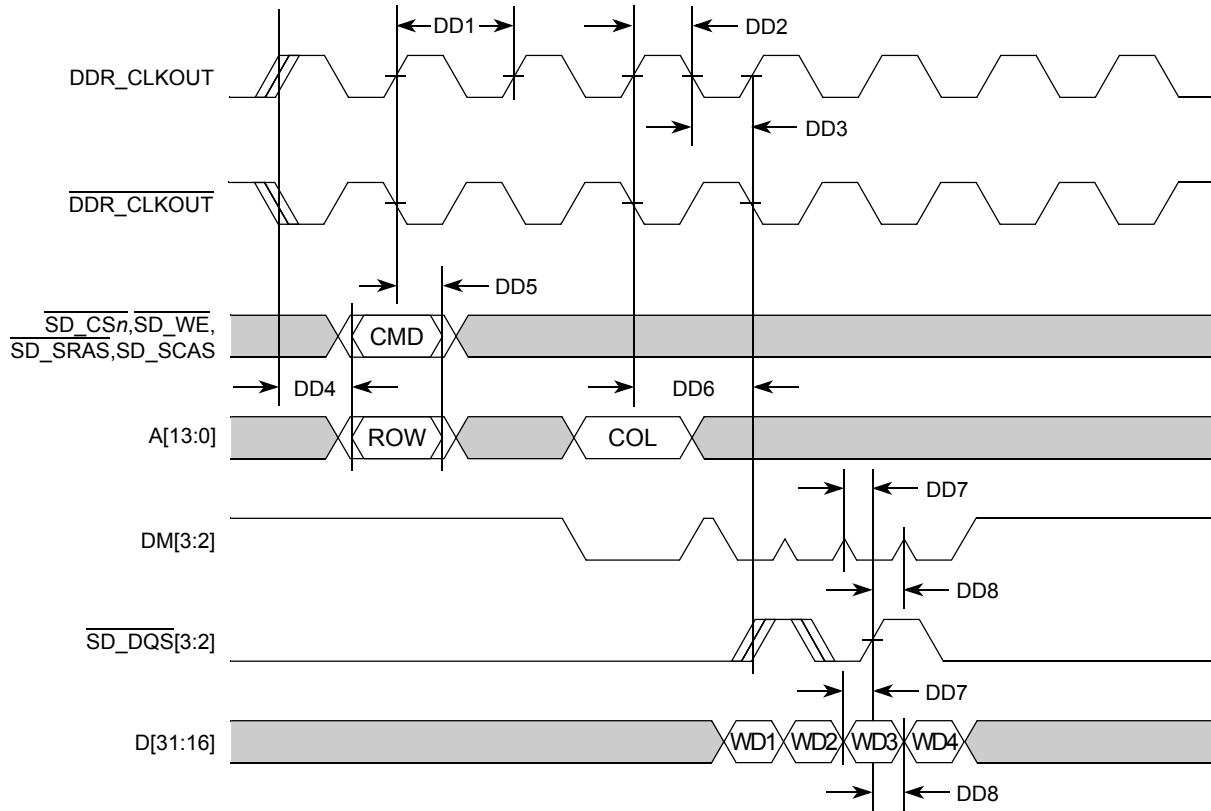

Figure 13. DDR Write Timing

Figure 14. DDR Read Timing

## 8.9 General Purpose I/O Timing

GPIO can be configured for certain pins of the QSPI, DDR control, timers, UARTS, FEC0, FEC1, Interrupts and USB interfaces. When in GPIO mode the timing specification for these pins is given in [Table 16](#) and [Figure 15](#).

Table 16. GPIO Timing

NUM	Characteristic	Symbol	Min	Max	Unit
G1	CLKOUT High to GPIO Output Valid	$t_{CHPOV}$	—	10	ns
G2	CLKOUT High to GPIO Output Invalid	$t_{CHPOI}$	1.0	—	ns
G3	GPIO Input Valid to CLKOUT High	$t_{PVCH}$	9	—	ns
G4	CLKOUT High to GPIO Input Invalid	t			



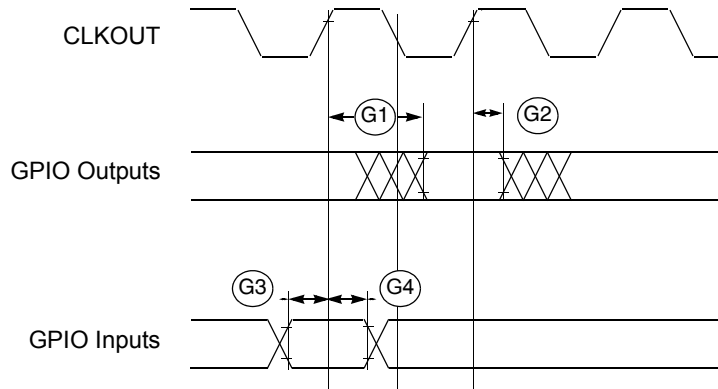

Figure 15. GPIO Timing

## 8.10 Reset and Configuration Override Timing

Table 17. Reset and Configuration Override Timing  
( $V_{DD} = 2.7$  to  $3.6$  V,  $V_{SS} = 0$  V,  $T_A = T_L$  to  $T_H$ )<sup>1</sup>

NUM	Characteristic	Symbol	Min	Max	Unit
R1	$\overline{RESET}$ Input valid to CLKOUT High	$t_{RVCH}$	9	—	ns
R2	CLKOUT High to $\overline{RESET}$ Input invalid	$t_{CHRI}$	1.5	—	ns
R3	$\overline{RESET}$ Input valid Time <sup>2</sup>	$t_{RIVT}$	5	—	$t_{CYC}$
R4	CLKOUT High to $\overline{RSTOUT}$ Valid	$t_{CHROV}$	—	10	ns
R5	$\overline{RSTOUT}$ valid to Config. Overrides valid	$t_{ROVCV}$	0	—	ns
R6	Configuration Override Setup Time to $\overline{RSTOUT}$ invalid	$t_{COS}$	20	—	$t_{CYC}$
R7	Configuration Override Hold Time after $\overline{RSTOUT}$ invalid	$t_{COH}$	0	—	ns
R8	$\overline{RSTOUT}$ invalid to Configuration Override High Impedance	$t_{ROICZ}$	—	$1 \times t_{CYC}$	ns

<sup>1</sup> All AC timing is shown with respect to 50%  $OV_{DD}$  levels unless otherwise noted.

<sup>2</sup> During low power STOP, the synchronizers for the  $\overline{RESET}$  input are bypassed and  $\overline{RESET}$  is asserted asynchronously to the system. Thus,  $\overline{RESET}$  must be held a minimum of 100 ns.

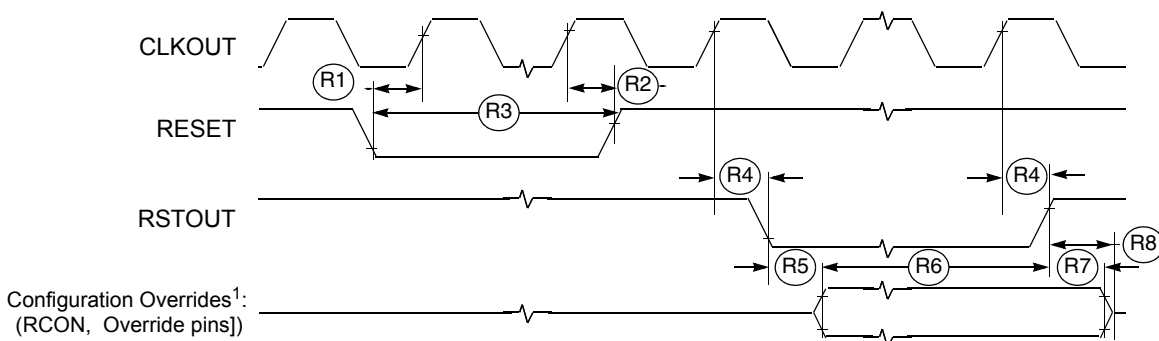

1. Refer to the Coldfire Integration Module (CIM) section for more information.

Reset and Configuration Override Timing

## 8.11 Fast Ethernet AC Timing Specifications

MII signals use TTL signal levels compatible with devices operating at 5.0 V or 3.3 V.

### 8.11.1 MII Receive Signal Timing (FECn\_RXD[3:0], FECn\_RXDV, FECn\_RXER, and FECn\_RXCLK)

The receiver functions correctly up to a FECn\_RXCLK maximum frequency of 25 MHz +1%. The processor clock frequency must exceed twice the FECn\_RXCLK frequency.

Table 18 lists MII receive channel timings.

Table 18. MII Receive Signal Timing

Num	Characteristic	Min	Max	Unit
M1	FECn_RXD[3:0], FECn_RXDV, FECn_RXER to FECn_RXCLK setup	5	—	ns
M2	FECn_RXCLK to FECn_RXD[3:0], FECn_RXDV, FECn_RXER hold	5	—	ns
M3	FECn_RXCLK pulse width high	35%	65%	FECn_RXCLK period
M4	FECn_RXCLK pulse width low	35%	65%	FECn_RXCLK period

Figure 16 shows MII receive signal timings listed in Table 18.

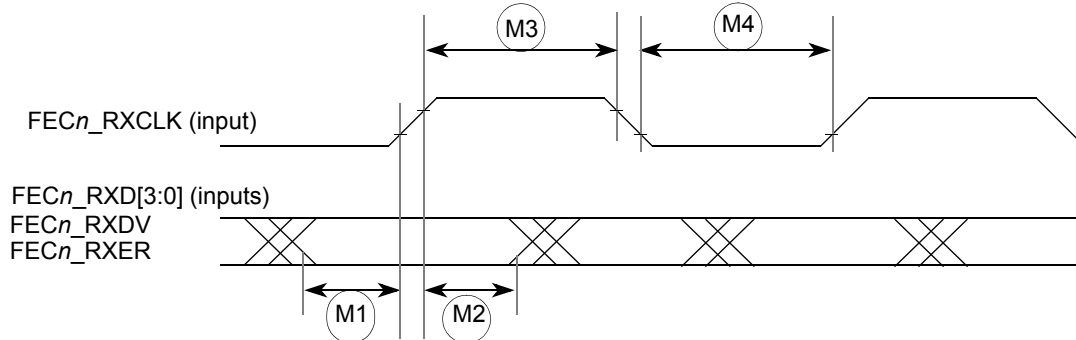

Figure 16. MII Receive Signal Timing Diagram

### 8.11.2 MII Transmit Signal Timing (FECn\_TXD[3:0], FECn\_TXEN, FECn\_TXER, FECn\_TXCLK)

Table 19 lists MII transmit channel timings.

The transmitter functions correctly up to a FECn\_TXCLK maximum frequency of 25 MHz +1%. The processor clock frequency must exceed twice the FECn\_TXCLK frequency.

**Table 19. MII Transmit Channel Timing**

Num	Characteristic	Min	Max	Unit
M5	FECn_TXCLK to FECn_TXD[3:0], FECn_TXEN, FECn_TXER invalid	5	—	ns
M6	FECn_TXCLK to FECn_TXD[3:0], FECn_TXEN, FECn_TXER valid	—	25	ns
M7	FECn_TXCLK pulse width high	35%	65%	FECn_TXCLK period
M8	FECn_TXCLK pulse width low	35%	65%	FECn_TXCLK period

Figure 17 shows MII transmit signal timings listed in Table 19.

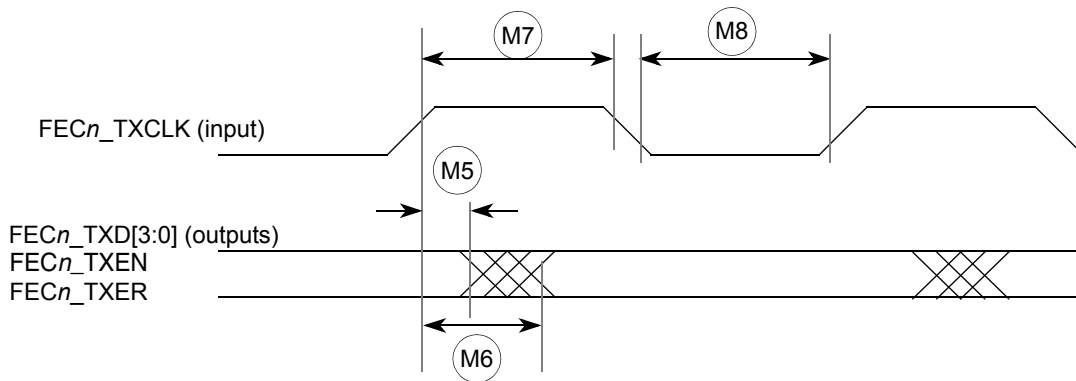

**Figure 17. MII Transmit Signal Timing Diagram**

### 8.11.3 MII Async Inputs Signal Timing (FECn\_CRIS and FECn\_COL)

Table 20 lists MII asynchronous inputs signal timing.

**Table 20. MII Asynchronous Input Signal Timing**

Num	Characteristic	Min	Max	Unit
M9	FECn_CRIS, FECn_COL minimum pulse width	1.5	—	FECn_TXCLK period

Figure 18 shows MII asynchronous input timings listed in Table 20.

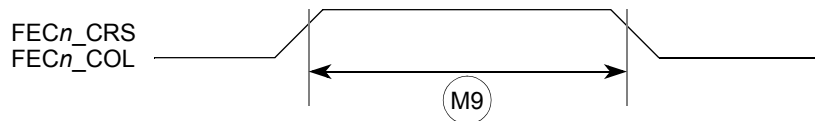

**Figure 18. MII Async Inputs Timing Diagram**

### 8.11.4 MII Serial Management Channel Timing (FEC<sub>n</sub>\_MDIO and FEC<sub>n</sub>\_MDC)

Table 21 lists MII serial management channel timings. The FEC functions correctly with a maximum MDC frequency of 2.5 MHz.

**Table 21. MII Serial Management Channel Timing**

Num	Characteristic	Min	Max	Unit
M10	FEC <sub>n</sub> _MDC falling edge to FEC <sub>n</sub> _MDIO output invalid (minimum propagation delay)	0	—	ns
M11	FEC <sub>n</sub> _MDC falling edge to FEC <sub>n</sub> _MDIO output valid (max prop delay)	—	25	ns
M12	FEC <sub>n</sub> _MDIO (input) to FEC <sub>n</sub> _MDC rising edge setup	10	—	ns
M13	FEC <sub>n</sub> _MDIO (input) to FEC <sub>n</sub> _MDC rising edge hold	0	—	ns
M14	FEC <sub>n</sub> _MDC pulse width high	40%	60%	MDC period
M15	FEC <sub>n</sub> _MDC pulse width low	40%	60%	MDC period

Figure 19 shows MII serial management channel timings listed in Table 21.

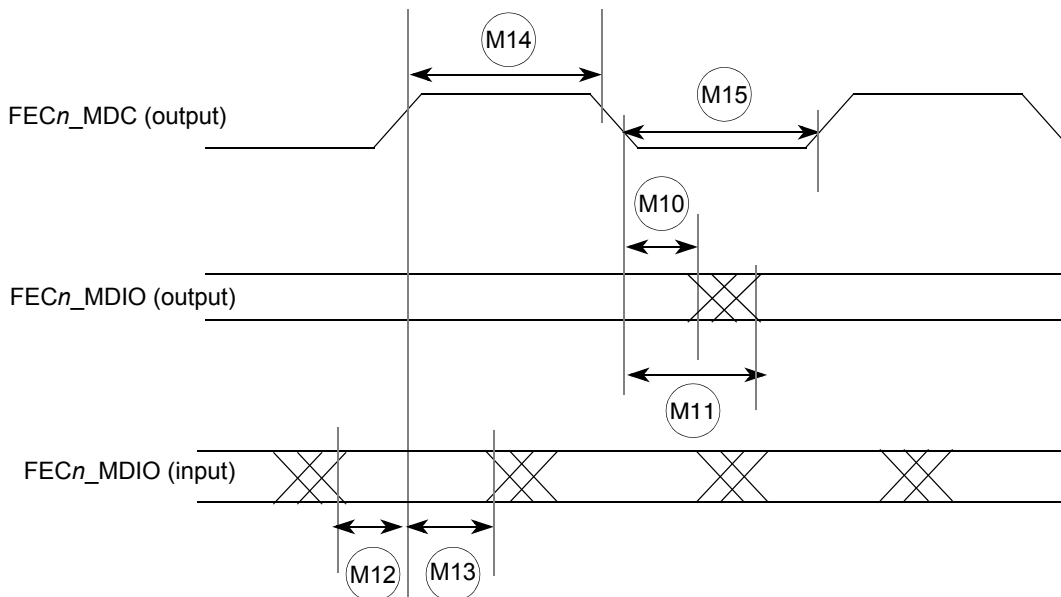

**Figure 19. MII Serial Management Channel Timing Diagram**

## 8.11.5 USB Interface AC Timing Specifications

Table 22 lists USB Interface timings.

Figure 20

## 8.12 I<sup>2</sup>C Input/Output Timing Specifications

Table 23 lists specifications for the I<sup>2</sup>C input timing parameters shown in Figure 21.

**Table 23. I<sup>2</sup>C Input Timing Specifications between I2C\_SCL and I2C\_SDA**

Num	Characteristic	Min	Max	Units
I1	Start condition hold time	2 x t <sub>CYC</sub>	—	ns
I2	Clock low period	8 x t <sub>CYC</sub>	—	ns
I3	I2C_SCL/I2C_SDA rise time (V <sub>IL</sub> = 0.5 V to V <sub>IH</sub> = 2.4 V)	—	1	ms
I4	Data hold time	0	—	ns
I5	I2C_SCL/I2C_SDA fall time (V <sub>IH</sub> = 2.4 V to V <sub>IL</sub> = 0.5 V)	—	1	ms
I6	Clock high time	4 x t <sub>CYC</sub>	—	ns
I7	Data setup time	0	—	ns
I8	Start condition setup time (for repeated start condition only)	2 x t <sub>CYC</sub>	—	ns
I9	Stop condition setup time	2 x t <sub>CYC</sub>	—	ns

Table 24 lists specifications for the I<sup>2</sup>C output timing parameters shown in Figure 21.

**Table 24. I<sup>2</sup>C Output Timing Specifications between I2C\_SCL and I2C\_SDA**

Num	Characteristic	Min	Max	Units
I1 <sup>1</sup>	Start condition hold time	6 x t <sub>CYC</sub>	—	ns
I2 <sup>1</sup>	Clock low period	10 x t <sub>CYC</sub>	—	ns
I3 <sup>2</sup>	I2C_SCL/I2C_SDA rise time (V <sub>IL</sub> = 0.5 V to V <sub>IH</sub> = 2.4 V)	—	—	μs
I4 <sup>1</sup>	Data hold time	7 x t <sub>CYC</sub>	—	ns
I5 <sup>3</sup>	I2C_SCL/I2C_SDA fall time (V <sub>IH</sub> = 2.4 V to V <sub>IL</sub> = 0.5 V)	—	3	ns
I6 <sup>1</sup>	Clock high time	10 x t <sub>CYC</sub>	—	ns
I7 <sup>1</sup>	Data setup time	2 x t <sub>CYC</sub>	—	ns
I8 <sup>1</sup>	Start condition setup time (for repeated start condition only)	20 x t <sub>CYC</sub>	—	ns
I9 <sup>1</sup>	Stop condition setup time	10 x t <sub>CYC</sub>	—	ns

<sup>1</sup> Output numbers depend on the value programmed into the IFDR; an IFDR programmed with the maximum frequency (IFDR = 0x20) results in minimum output timings as shown in Table 24. The I<sup>2</sup>C interface is designed to scale the actual data transition time to move it to the middle of the I2C\_SCL low period. The actual position is affected by the prescale and division values programmed into the IFDR; however, the numbers given in Table 24 are minimum values.

<sup>2</sup> Because I2C\_SCL and I2C\_SDA are open-collector-type outputs, which the processor can only actively drive low, the time I2C\_SCL or I2C\_SDA take to reach a high level depends on external signal capacitance and pull-up resistor values.

<sup>3</sup> Specified at a nominal 50-pF load.

Figure 21 shows timing for the values in Table 23 and Table 24.

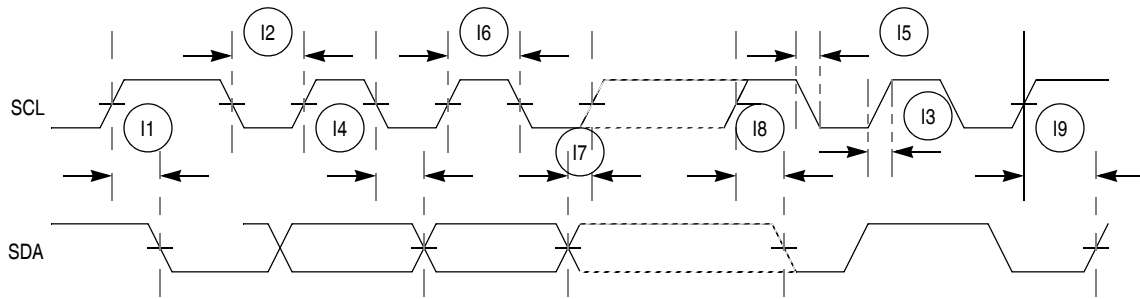

Figure 21. I<sup>2</sup>C Input/Output Timings

### 8.13 DMA Timers Timing Specifications

Table 25. Timer Module AC Timing Specifications

Name	Characteristic <sup>1</sup>	Min	Max	Unit
T1	T0IN / T1IN / T2IN / T3IN cycle time	3 x t <sub>CYC</sub>	—	ns
T2	T0IN / T1IN / T2IN / T3IN pulse width	1 x t <sub>CYC</sub>	—	ns

<sup>1</sup> All timing references to CLKOUT are given to its rising edge.

### 8.14 QSPI Electrical Specifications

Table 26. QSPI Modules AC Timing Specifications

Name	Characteristic	Min	Max	Unit
QS1	QSPI_CS[3:0] to QSPI_CLK	1	510	t <sub>CYC</sub>
QS2	QSPI_CLK high to QSPI_DOUT valid.	—	10	ns
QS3	QSPI_CLK high to QSPI_DOUT invalid (Output hold)	2	—	ns
QS4	QSPI_DIN to QSPI_CLK (Input setup)	9	—	ns
QS5	QSPI_DIN to QSPI_CLK (Input hold)	9	—	ns

## Preliminary Electrical Characteristics

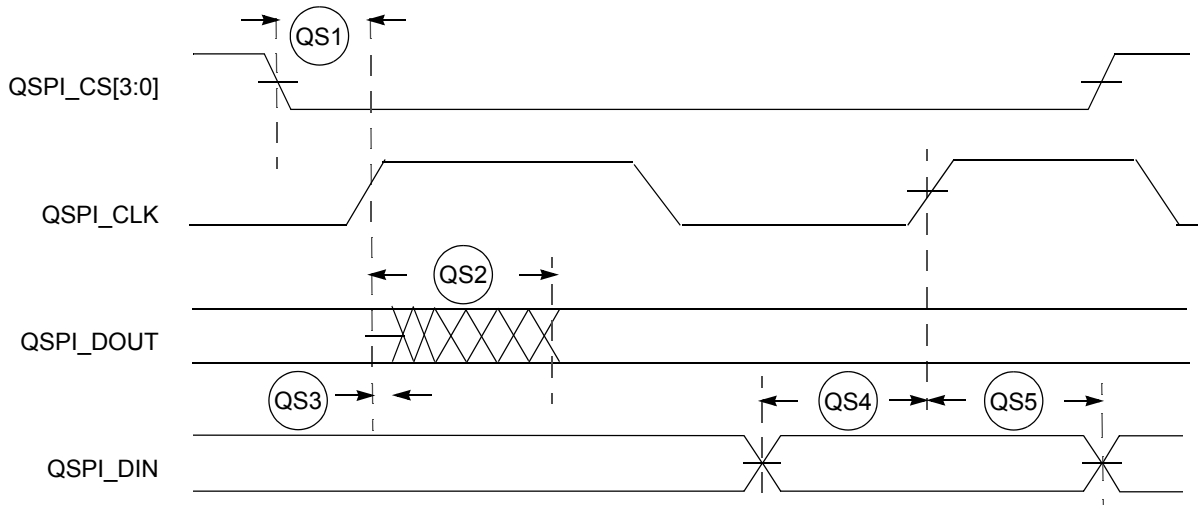

Figure 22. QSPI Timing

## 8.15 JTAG and Boundary Scan Timing

Table 27. JTAG and Boundary Scan Timing

Num	Characteristics <sup>1</sup>	Symbol	Min	Max	Unit
J1	TCLK Frequency of Operation	$f_{JCYC}$	DC	1/4	$f_{sys}/2$
J2	TCLK Cycle Period	$t_{JCYC}$	$4 \times t_{CYC}$	—	ns
J3	TCLK Clock Pulse Width	$t_{JCW}$	26	—	ns
J4	TCLK Rise and Fall Times	$t_{JCRF}$	0	3	ns
J5	Boundary Scan Input Data Setup Time to TCLK Rise	$t_{BSDST}$	4	—	ns
J6	Boundary Scan Input Data Hold Time after TCLK Rise	$t_{BSDHT}$	26	—	ns
J7	TCLK Low to Boundary Scan Output Data Valid	$t_{BSDV}$	0	33	ns
J8	TCLK Low to Boundary Scan Output High Z	$t_{BSDZ}$	0	33	ns
J9	TMS, TDI Input Data Setup Time to TCLK Rise	$t_{TAPBST}$	4	—	ns
J10	TMS, TDI Input Data Hold Time after TCLK Rise	$t_{TAPBHT}$	10	—	ns
J11	TCLK Low to TDO Data Valid	$t_{TDODV}$	0	26	ns
J12	TCLK Low to TDO High Z	$t_{TDODZ}$	0	8	ns
J13	$\overline{TRST}$ Assert Time	$t_{TRSTAT}$	100	—	ns
J14	$\overline{TRST}$ Setup Time (Negation) to TCLK High	$t_{TRSTST}$	10	—	ns

<sup>1</sup> JTAG\_EN is expected to be a static signal. Hence, it is not associated with any timing.



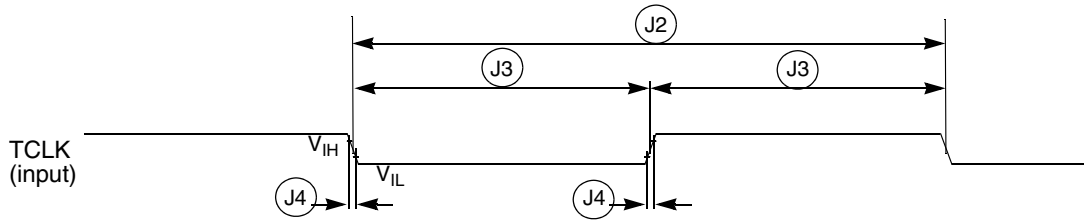

Figure 23. Test Clock Input Timing

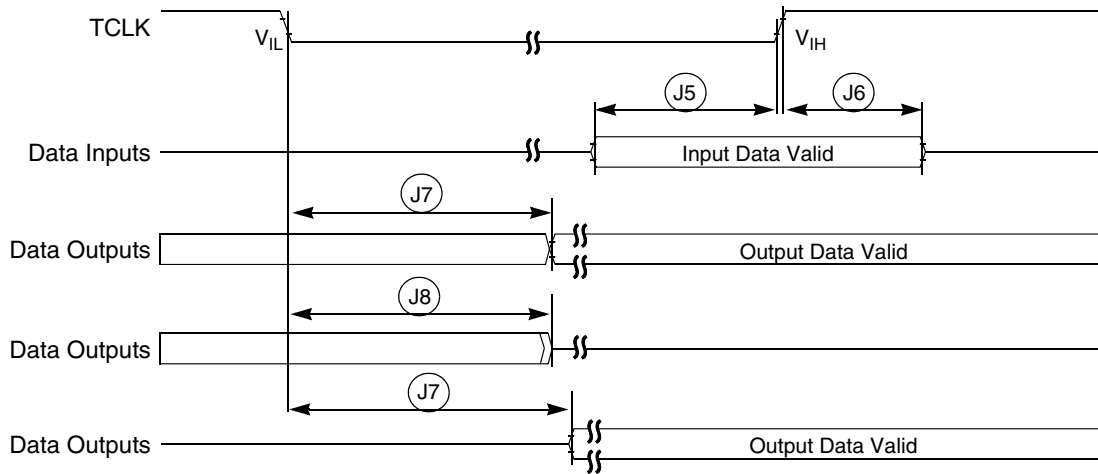

Figure 24. Boundary Scan (JTAG) Timing

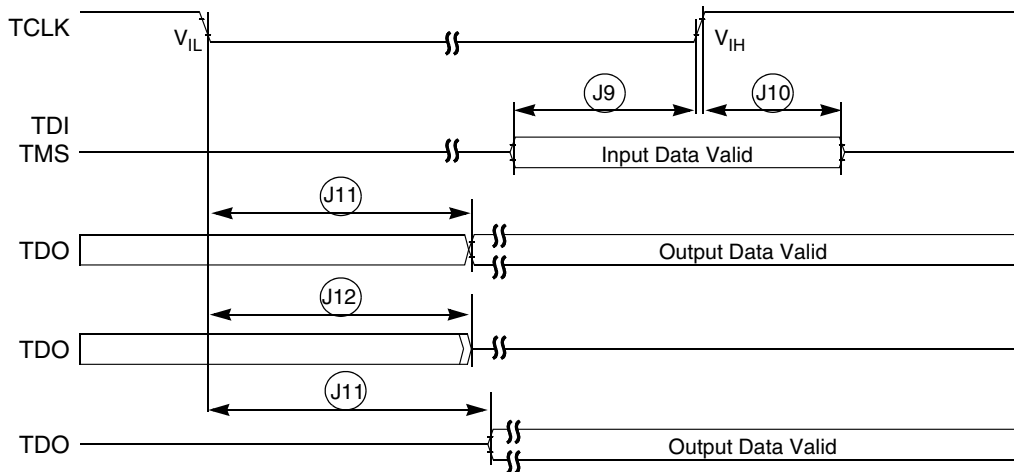

Figure 25. Test Access Port Timing

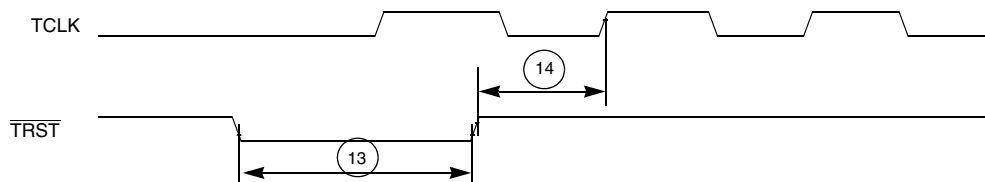

Figure 26. TRST Timing

## 8.16 Debug AC Timing Specifications

Table 28 lists specifications for the debug AC timing parameters shown in Figure 28.

Table 28. Debug AC Timing Specification

Num	Characteristic	166 MHz		Units
		Min	Max	
D0	PSTCLK cycle time	—	0.5	$t_{CYC}$
D1	PST, DDATA to PSTCLK setup	4	—	ns
D2	CLKOUT to PST, DDATA hold	1.0	—	ns
D3	DSI-to-DSCLK setup	$1 \times t_{CYC}$	—	ns
D4 <sup>1</sup>	DSCLK-to-DSO hold	$4 \times t_{CYC}$	—	ns
D5	DSCLK cycle time	$5 \times t_{CYC}$	—	ns
D6	$\overline{BKPT}$ input data setup time to PSTCLK Rise	4	—	ns
D7	$\overline{BKPT}$ input data hold time to PSTCLK Rise	1.5	—	ns
D8	PSTCLK high to $\overline{BKPT}$ high Z	0.0	10.0	ns

<sup>1</sup> DSCLK and DSI are synchronized internally. D4 is measured from the synchronized DSCLK input relative to the rising edge of PSTCLK.

Figure 27 shows real-time trace timing for the values in Table 28.

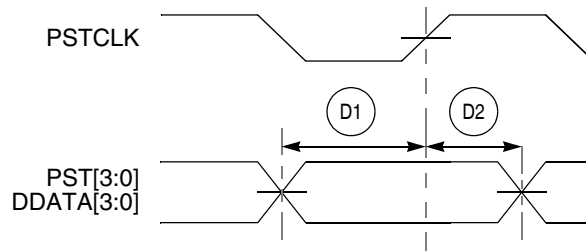

Figure 27. Real-Time Trace AC Timing

Figure 28 shows BDM serial port AC timing for the values in Table 28.

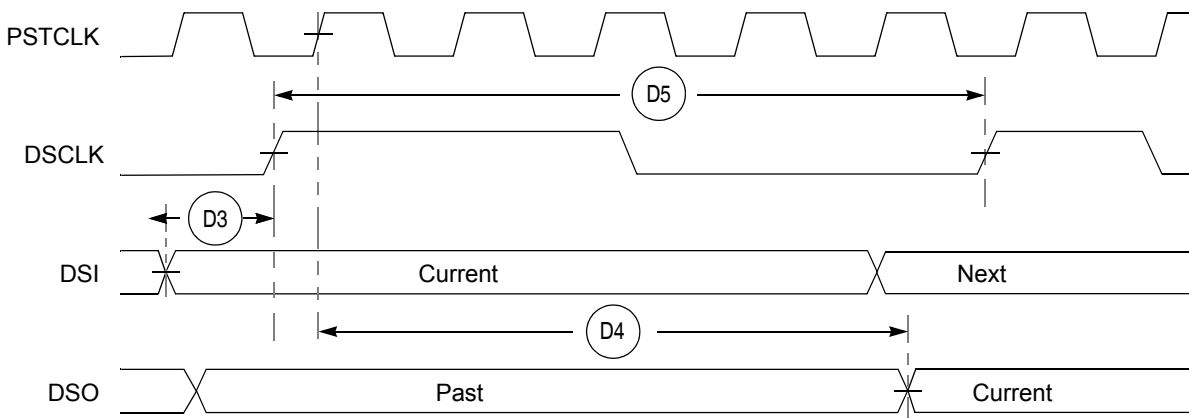

Figure 28. BDM Serial Port AC Timing

## 9 Documentation

Documentation regarding the MCF5275 and their development support tools is available from a local Freescale distributor, a Freescale semiconductor sales office, the Freescale Literature Distribution Center, or through the Freescale web address at <http://www.freescale.com/coldfire>.

## 10 Revision History

Table 29 provides a revision history for this hardware specification.

**Table 29. Document Revision History**

Rev. No.	Substantive Change(s)
0	Initial release.
1	Added <a href="#">Figure 6</a> .
1.1	Removed duplicate information in the module description sections. The information is all in the Signals Description Table.
1.2	Removed Overview, Features, Signal Descriptions, Modes of Operation, and Address Multiplexing sections. This information can be found in the MCF5275 Reference Manual. Removed list of documentation in <a href="#">Section 9, "Documentation."</a> An up-to-date list is always available on our web site. Changed CLKOUT -> PSTCLK in <a href="#">Section 8.16, "Debug AC Timing Specifications."</a> <a href="#">Table 10</a> : Update $V_{DD}$ spec from 1.35-1.65 to 1.4-1.6. <a href="#">Table 13</a> : Timings B6a, B6b, B6c, B7, B7a, B9, B12 updated: B6a, B6b, B6c maximum changed from " $0.5t_{CYC} + 5$ " to " $0.5t_{CYC} + 5.5$ " B7, B7a minimum changed from " $0.5t_{CYC} + 1.5$ " to " $0.5t_{CYC} + 1.0$ " B9, B11 minimum changed from "1.5" to "1.0"
1.3	Added <a href="#">Section 5.2.1, "Supply Voltage Sequencing and Separation Cautions."</a> Added thermal characteristics for 196 MAPBGA in <a href="#">Table 8</a> . Updated package dimensions drawing, <a href="#">Figure 6</a> .
2	Removed second sentence from <a href="#">Section 8.11.1, "MII Receive Signal Timing (FECn_RXD[3:0], FECn_RXDV, FECn_RXER, and FECn_RXCLK),"</a> and <a href="#">Section 8.11.2, "MII Transmit Signal Timing (FECn_TXD[3:0], FECn_TXEN, FECn_TXER, FECn_TXCLK),"</a> regarding no minimum frequency requirement for TXCLK. Removed third and fourth paragraphs from <a href="#">Section 8.11.2, "MII Transmit Signal Timing (FECn_TXD[3:0], FECn_TXEN, FECn_TXER, FECn_TXCLK),"</a> as this feature is not supported on this device.
3	Corrected Ordering Information, <a href="#">Table 6</a> . <a href="#">Figure 2</a> : Moved PLLV <sub>DD</sub> from 1.5V to 3.3V supply line and corrected relevant text in sections below table. <a href="#">Table 10</a> : Corrected maximum "Input High Voltage 3.3V I/O Pads", $V_{IH}$ specification.

## How to Reach Us:

### Home Page:

[www.freescale.com](http://www.freescale.com)

### E-mail:

[support@freescale.com](mailto:support@freescale.com)

### USA/Europe or Locations Not Listed:

Freescale Semiconductor  
Technical Information Center, CH370  
1300 N. Alma School Road  
Chandler, Arizona 85224  
+1-800-521-6274 or +1-480-768-2130  
[support@freescale.com](mailto:support@freescale.com)

### Europe, Middle East, and Africa:

Freescale Halbleiter Deutschland GmbH  
Technical Information Center  
Schatzbogen 7  
81829 Muenchen, Germany  
+44 1296 380 456 (English)  
+46 8 52200080 (English)  
+49 89 92103 559 (German)  
+33 1 69 35 48 48 (French)  
[support@freescale.com](mailto:support@freescale.com)

### Japan:

Freescale Semiconductor Japan Ltd.  
Headquarters  
ARCO Tower 15F  
1-8-1, Shimo-Meguro, Meguro-ku,  
Tokyo 153-0064  
Japan  
0120 191014 or +81 3 5437 9125  
[support.japan@freescale.com](mailto:support.japan@freescale.com)

### Asia/Pacific:

Freescale Semiconductor Hong Kong Ltd.  
Technical Information Center  
2 Dai King Street  
Tai Po Industrial Estate  
Tai Po, N.T., Hong Kong  
+800 2666 8080  
[support.asia@freescale.com](mailto:support.asia@freescale.com)

### For Literature Requests Only:

Freescale Semiconductor Literature Distribution Center  
P.O. Box 5405  
Denver, Colorado 80217  
1-800-441-2447 or 303-675-2140  
Fax: 303-675-2150  
[LDCForFreescaleSemiconductor@hibbertgroup.com](mailto:LDCForFreescaleSemiconductor@hibbertgroup.com)

Document Number: MCF5275EC  
Rev. 3  
09/2007

Information in this document is provided solely to enable system and software implementers to use Freescale Semiconductor products. There are no express or implied copyright licenses granted hereunder to design or fabricate any integrated circuits or integrated circuits based on the information in this document.

Freescale Semiconductor reserves the right to make changes without further notice to any products herein. Freescale Semiconductor makes no warranty, representation or guarantee regarding the suitability of its products for any particular purpose, nor does Freescale Semiconductor assume any liability arising out of the application or use of any product or circuit, and specifically disclaims any and all liability, including without limitation consequential or incidental damages. "Typical" parameters that may be provided in Freescale Semiconductor data sheets and/or specifications can and do vary in different applications and actual performance may vary over time. All operating parameters, including "Typicals", must be validated for each customer application by customer's technical experts. Freescale Semiconductor does not convey any license under its patent rights nor the rights of others. Freescale Semiconductor products are not designed, intended, or authorized for use as components in systems intended for surgical implant into the body, or other applications intended to support or sustain life, or for any other application in which the failure of the Freescale Semiconductor product could create a situation where personal injury or death may occur. Should Buyer purchase or use Freescale Semiconductor products for any such unintended or unauthorized application, Buyer shall indemnify and hold Freescale Semiconductor and its officers, employees, subsidiaries, affiliates, and distributors harmless against all claims, costs, damages, and expenses, and reasonable attorney fees arising out of, directly or indirectly, any claim of personal injury or death associated with such unintended or unauthorized use, even if such claim alleges that Freescale Semiconductor was negligent regarding the design or manufacture of the part.

Freescale™ and the Freescale logo are trademarks of Freescale Semiconductor, Inc. All other product or service names are the property of their respective owners.

© Freescale Semiconductor, Inc. 2007. All rights reserved.

RoHS-compliant and/or Pb-free versions of Freescale products have the functionality and electrical characteristics as their non-RoHS-compliant and/or non-Pb-free counterparts. For further information, see <http://www.freescale.com> or contact your Freescale sales representative.

For information on Freescale's Environmental Products program, go to <http://www.freescale.com/epp>.

**Preliminary—Subject to Change Without Notice**

