

13 12 11 10 9 8 7 6 5 4 3 2 1

J
I
H
G
F
E
D
C
B
A

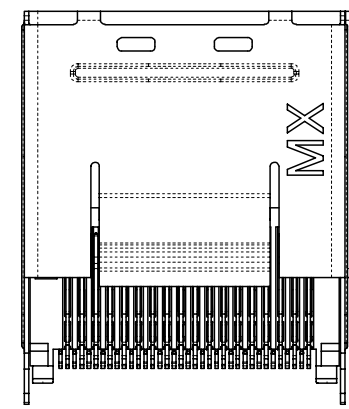
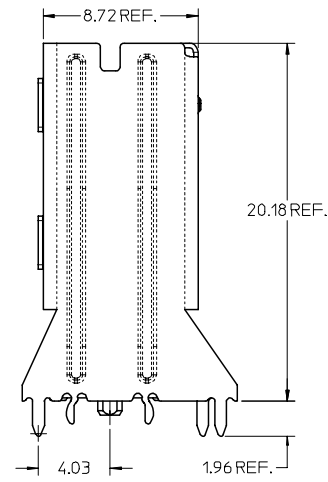
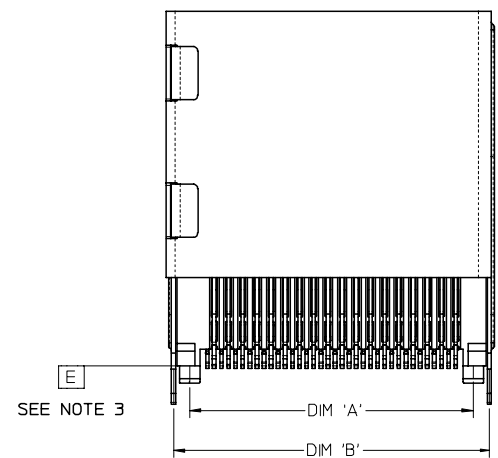
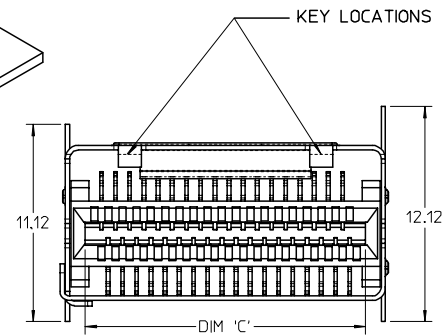
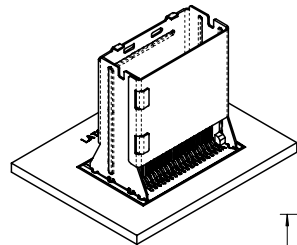

36 CIRCUIT RETENTION-FIT SHELL OPTION SHOWN

- NOTES:
- MATERIAL:
CONNECTOR:
HOUSING - HIGH TEMPERATURE THERMOPLASTIC GLASS FILLED, UL 94V-0, BLACK
TERMINALS - COPPER ALLOY
SHELL
NICKEL SILVER, C770, THICKNESS: 0.250/0.254
 - FINISH:
CONNECTOR
OPTION 1
CONTACT AREA - 0.38µm MIN GOLD OVER 2.54 µm NICKEL
SOLDER FOOT AREA - 2.54-5.09µm TIN OVER 2.54 µm NICKEL
OPTION 2
CONTACT AREA - 0.76µm MIN GOLD OVER 2.54 µm NICKEL
SOLDER FOOT AREA - 2.54-5.09µm TIN OVER 2.54 µm NICKEL
 - TERMINAL SOLDER FEET TO BE COPLANAR WITHIN 0.10 MEASURED FROM DATUM E
 - DATE CODE: 4 DIGIT (3 DIGIT DAY, 1 DIGIT YEAR) ON CONNECTOR ONLY
 - CIRCUIT IDENTIFIER: SEE APPROPRIATE INDUSTRY SPECIFICATION FOR LOCATION OF PIN 1
 - TO BE USED WITH CABLES (79536/79575/79576/79579/79580 SERIES)
 - PACKAGED PER PACKAGING SPECIFICATION: PK-75783-001
 - CONFORMS TO PRODUCT SPECIFICATION: PS-75783-001
 - PROCESS PER APPLICATION SPECIFICATION: AS-75783-001

iPass™ IS A TRADEMARK OF MOLEX

CIRCUIT SIZE	DIM 'A'	DIM 'B'	DIM 'C'
26	12.00	13.80	11.80
36	16.00	17.80	15.80
50	21.60	23.40	21.40
68	28.80	30.60	28.60

REV C1 ADDED SHEET 3 EC NO: UCP2006-2031 DRWN: J.SWENSON 2006/03/21 CHKD: 2006/03/21 APPR: MBANAKIS 2006/03/22	QUALITY SYMBOLS ▽=0 ▽=0	GENERAL TOLERANCES (UNLESS SPECIFIED) mm INCH 4 PLACES ± --- ± --- 3 PLACES ± --- ± --- 2 PLACES ± 0.13 ± --- 1 PLACE ± 0.25 ± --- ANGULAR ±1/2°	DIMENSION STYLE MM ONLY DRAWN BY DATE KLANG 02/09/05 CHECKED BY DATE JSWENSON 02/09/05 APPROVED BY DATE MBANAKIS 02/02/05 MATERIAL NO.	SCALE 5:1 DESIGN UNITS METRIC THIRD ANGLE PROJECTION	TITLE I-PASS VERT CONNECTOR INTERNAL ASSY W/SHELL 0.8MM PITCH I/O MOLEX INCORPORATED DOCUMENT NO. SD-75784-001 SHEET NO. 1 OF 10		
		DRAFT WHERE APPLICABLE MUST REMAIN WITHIN DIMENSIONS		SEE CHART	THIS DRAWING CONTAINS INFORMATION THAT IS PROPRIETARY TO MOLEX INCORPORATED AND SHOULD NOT BE USED WITHOUT WRITTEN PERMISSION		

12 11 10 9 8 7 6 5 4 3 2 1

MATING INTERFACE

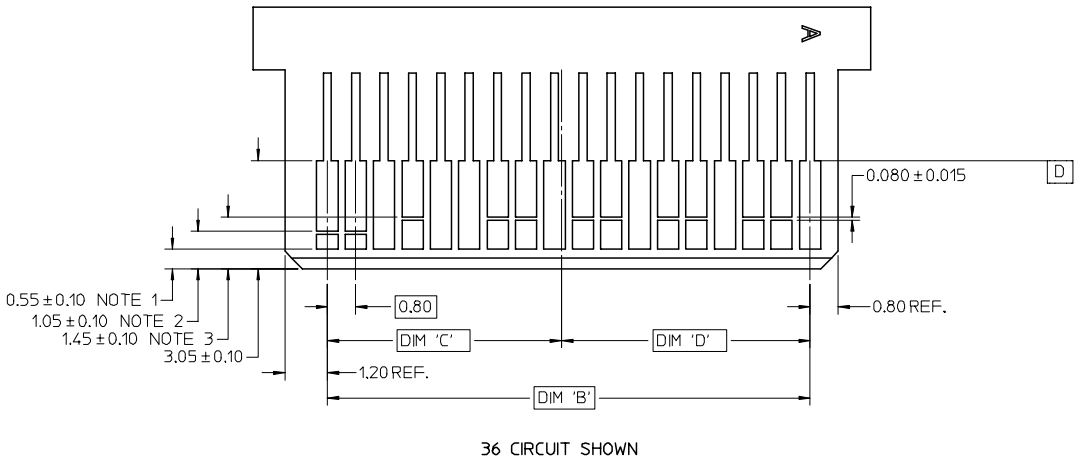
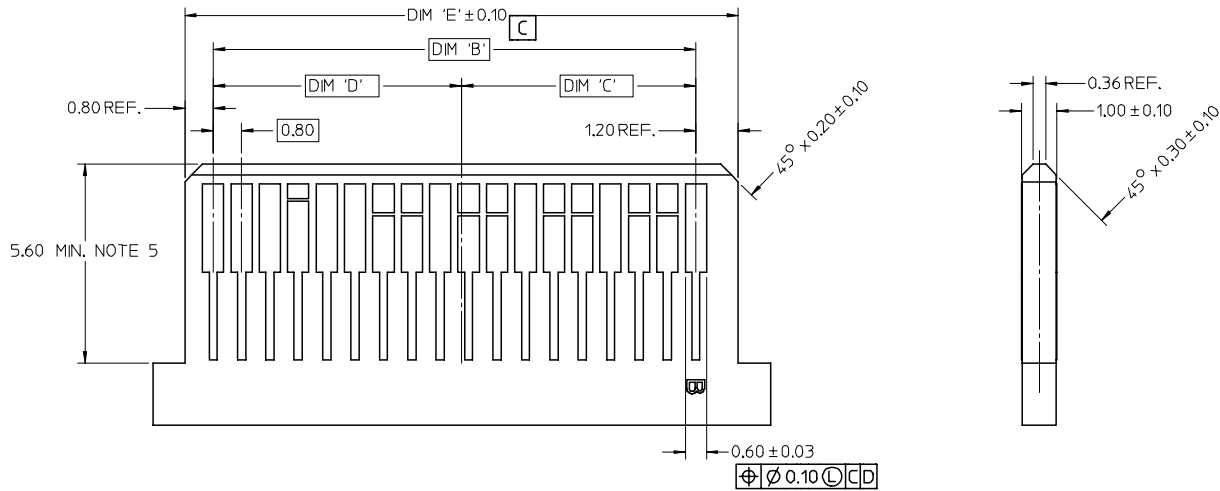

- NOTES:
- PAD CONFIGURATION FOR FIRST MATE.
 - PAD CONFIGURATION FOR SECOND MATE.
 - PAD CONFIGURATION FOR THIRD MATE. (HIGH SPEED SIGNALS)
 - FOR PIN ASSIGNMENTS AND MATING SEQUENCE (1ST, 2ND, 3RD), SEE APPLICABLE SPECIFICATION.
 - MINIMUM STEP REQUIRED IF PCB MADE WIDER THAN TOUNGE.

iPass™ IS A TRADEMARK OF MOLEX

CIRCUIT SIZE	TERM/SIDE 'N'	DIM 'B'	DIM 'C'	DIM 'D'	DIM 'E'
26	13	9.60	4.60	5.00	11.60
36	18	13.60	6.60	7.00	15.60
50	25	19.20	9.40	9.80	21.20
68	34	26.40	13.00	13.40	28.40

SEE SHEET 1
 FCC NO: UCP2006-2031
 DRAWN: J.SWENSON 2006/03/21
 CHFKD: 2006/03/21
 APPR: MBANAKIS 2006/03/22

QUALITY SYMBOLS
 ▽=0
 ▽=0

GENERAL TOLERANCES (UNLESS SPECIFIED)

	mm	INCH
4 PLACES	± .10	± .004
3 PLACES	± .13	± .005
2 PLACES	± 0.13	± .005
1 PLACE	± 0.25	± .010

ANGULAR ±1/2°

DRAFT WHERE APPLICABLE MUST REMAIN WITHIN DIMENSIONS

DIMENSION STYLE
 MM ONLY

DRAWN BY: KLANG
 DATE: 02/09/05

CHECKED BY: JSWENSON
 DATE: 02/09/05

APPROVED BY: MBANAKIS
 DATE: 02/02/05

MATERIAL NO.

SIZE: C

SCALE: 10:1

DESIGN UNITS: METRIC

THIRD ANGLE PROJECTION

TITLE: I-PASS VERT CONNECTOR INTERNAL ASSY W/SHELL 0.8MM PITCH I/O

MOLEX INCORPORATED

DOCUMENT NO. SD-75784-001

SHEET NO. 10 OF 10

THIS DRAWING CONTAINS INFORMATION THAT IS PROPRIETARY TO MOLEX INCORPORATED AND SHOULD NOT BE USED WITHOUT WRITTEN PERMISSION

KEYING OPTIONS

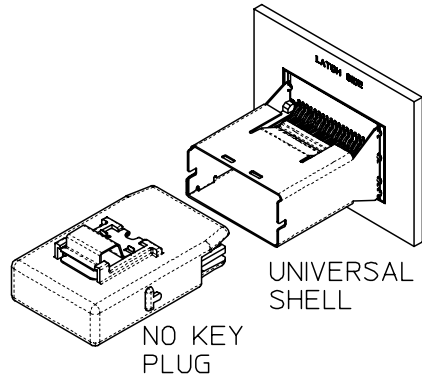
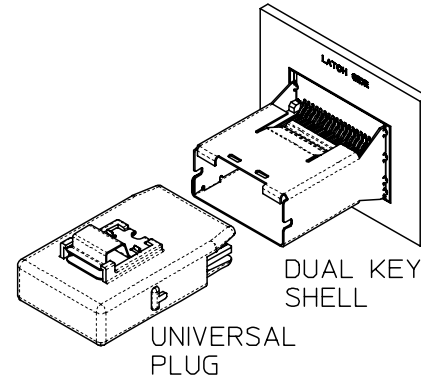
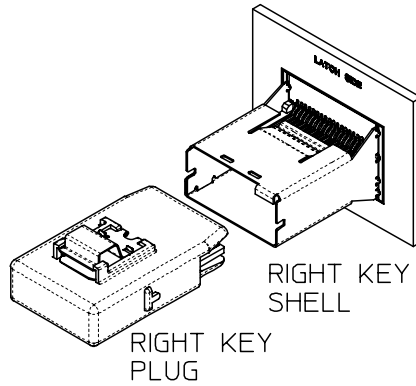
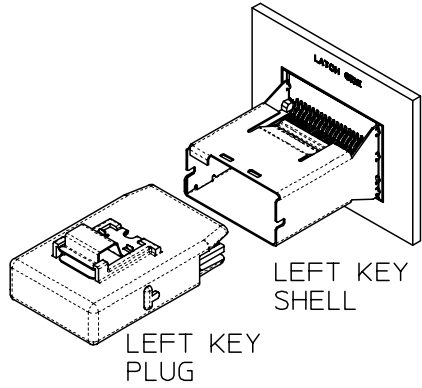

	UNIVERSAL SHELL	LEFT KEY SHELL	RIGHT KEY SHELL	DUAL KEY SHELL
NO KEY PLUG	YES	NO	NO	NO
LEFT KEY PLUG	YES	YES	NO	NO
RIGHT KEY PLUG	YES	NO	YES	NO
UNIVERSAL PLUG	YES	YES	YES	YES

SHELL PCB INTERFACE

RETENTION FIT SHELL

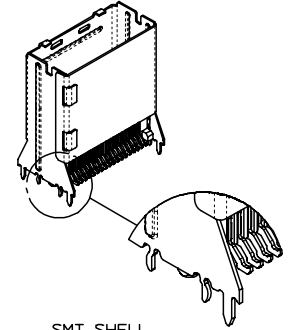

SMT SHELL

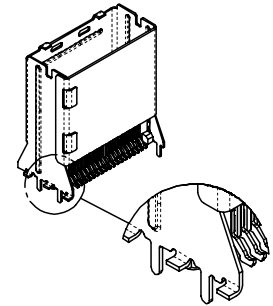

THROUGH HOLE SHELL

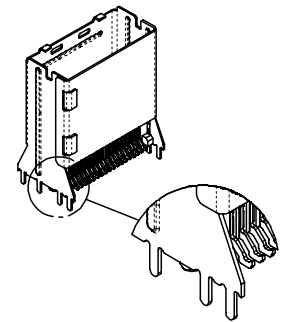

iPass™ IS A TRADEMARK OF MOLEX

PICK & PLACE / PRE-POSITIONING DEVICE

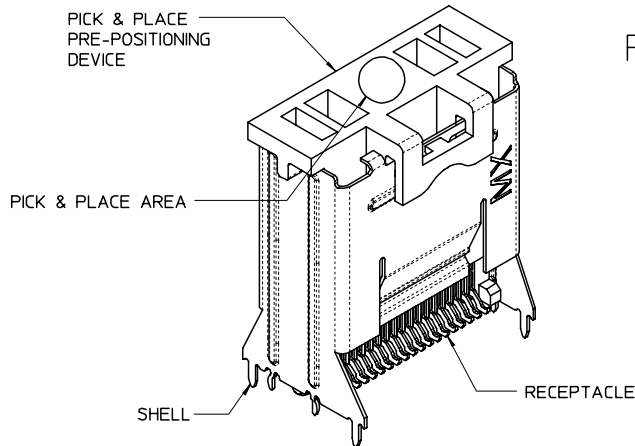

SEE SHEET 1 FC NO: UCP2006-2031 DRAWN: J. SWENSON 2006/03/27 CHKD: 2006/03/27 APPR: MBANAKIS 2006/03/22	QUALITY SYMBOLS =0 =0	GENERAL TOLERANCES (UNLESS SPECIFIED)		DIMENSION STYLE MM ONLY		SCALE 2:1	DESIGN UNITS METRIC	THIRD ANGLE PROJECTION
		mm	INCH	DRAWN BY KLANG	DATE 02/09/05	TITLE I-PASS VERT CONNECTOR INTERNAL ASSY W/SHELL 0.8MM PITCH I/O		
		4 PLACES ± --- ± ---		CHECKED BY JSWENSON	DATE 02/09/05	MOLEX INCORPORATED		
		3 PLACES ± --- ± ---		APPROVED BY MBANAKIS	DATE 02/02/05	DOCUMENT NO. SD-75784-001		SHEET NO. 2 OF 10
		2 PLACES ± 0.13 ± ---		DRAFT WHERE APPLICABLE MUST REMAIN WITHIN DIMENSIONS		SEE CHART		
		1 PLACE ± 0.25 ± ---		SIZE C		THIS DRAWING CONTAINS INFORMATION THAT IS PROPRIETARY TO MOLEX INCORPORATED AND SHOULD NOT BE USED WITHOUT WRITTEN PERMISSION		
		ANGULAR ±1/2°						

13 12 11 10 9 8 7 6 5 4 3 2 1

J

I

H

G

F

E

D

C

B

A

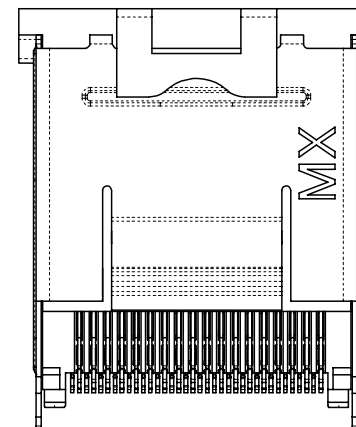
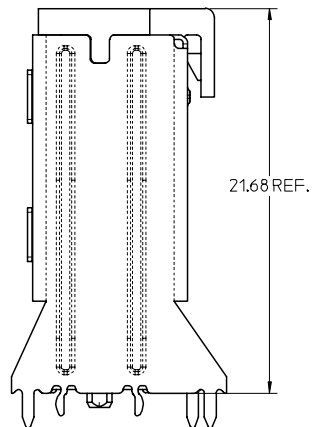
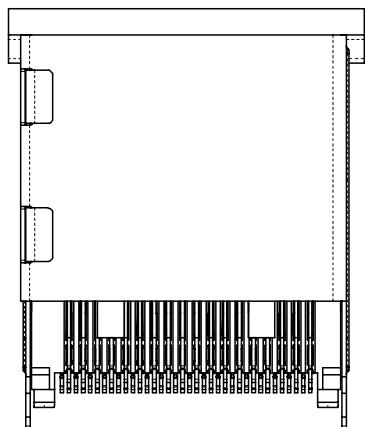
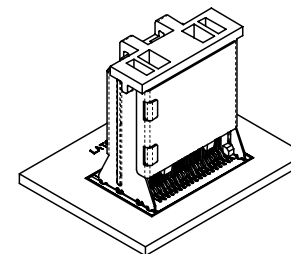
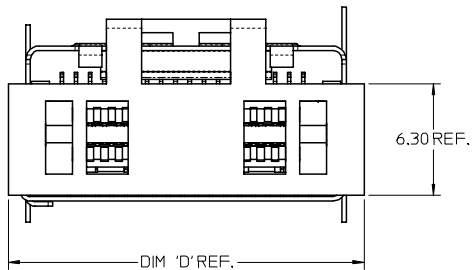

NOTES:

- PICK AND PLACE LOCATION DEFINED ON APPLICATION SPECIFICATION AS-75783-001

CIRCUIT SIZE	DIM 'D'
26	16.05
36	20.05
50	25.65
68	32.85

iPass™ IS A TRADEMARK OF MOLEX

SEE SHEET 1 FCC NO: UCP2006-2031 DRAWN: J.SWENSON 2006/03/21 CHKD: 2006/03/21 APPR: MBANAKIS 2006/03/22 REV:	QUALITY SYMBOLS ▽=0 ▽=0	GENERAL TOLERANCES (UNLESS SPECIFIED)		DIMENSION STYLE MM ONLY		SCALE 5:1	DESIGN UNITS METRIC	THIRD ANGLE PROJECTION	
		4 PLACES ± --- ± --- 3 PLACES ± --- ± --- 2 PLACES ± 0.13 ± --- 1 PLACE ± 0.25 ± --- ANGULAR ±1/2°	mm INCH	DRAWN BY KLANG	DATE 02/09/05	TITLE I-PASS VERT CONNECTOR INTERNAL ASSY W/SHELL 0.8MM PITCH I/O			
		DRAFT WHERE APPLICABLE MUST REMAIN WITHIN DIMENSIONS		CHECKED BY JSWENSON	DATE 02/09/05	APPROVED BY MBANAKIS			
		SEE CHART		MATERIAL NO.	DATE 02/02/05	MOLEX INCORPORATED		DOCUMENT NO. SD-75784-001	SHEET NO. 3 OF 10

12 11 10 9 8 7 6 5 4 3 2 1

J
I
H
G
F
E
D
C
B
A

26 CIRCUIT ITEM NUMBERS

CIRCUIT SIZE	ITEM NUMBER	PLATING OPTION	SHELL PCB OPTION	SHELL KEY OPTION
26	75784-0007	OPTION 1	RETENTION	LEFT
26	75784-0008	OPTION 1	RETENTION	RIGHT
26	75784-0009	OPTION 1	RETENTION	DUAL
26	75784-0010	OPTION 1	SMT	LEFT
26	75784-0011	OPTION 1	SMT	RIGHT
26	75784-0012	OPTION 1	SMT	DUAL
26	75784-0019	OPTION 2	RETENTION	LEFT
26	75784-0020	OPTION 2	RETENTION	RIGHT
26	75784-0021	OPTION 2	RETENTION	DUAL
26	75784-0022	OPTION 2	SMT	LEFT
26	75784-0023	OPTION 2	SMT	RIGHT
26	75784-0024	OPTION 2	SMT	DUAL
26	75784-0025	OPTION 1	RETENTION	UNIVERSAL
26	75784-0026	OPTION 1	SMT	UNIVERSAL
26	75784-0027	OPTION 2	RETENTION	UNIVERSAL
26	75784-0028	OPTION 2	SMT	UNIVERSAL
26	75784-0029	OPTION 1	THRU HOLE	LEFT
26	75784-0030	OPTION 1	THRU HOLE	RIGHT
26	75784-0031	OPTION 1	THRU HOLE	DUAL
26	75784-0032	OPTION 1	THRU HOLE	UNIVERSAL
26	75784-0033	OPTION 2	THRU HOLE	LEFT
26	75784-0034	OPTION 2	THRU HOLE	RIGHT
26	75784-0035	OPTION 2	THRU HOLE	DUAL
26	75784-0036	OPTION 2	THRU HOLE	UNIVERSAL

NOTE:

- PACKAGING CONSISTS OF CONNECTOR AND SHELL WITH A PRE-POSITIONING PICK AND PLACE DEVICE THAT ARE PACKAGED IN 'TAPE AND REEL' FOR ROBOTIC PICK AND PLACE.

iPass™ IS A TRADEMARK OF MOLEX

SEE SHEET 1 FC NO: UCP2006-2031 DRAWN: J.SWENSON 2006/03/21 CHKD: 2006/03/21 APPR: MBANAK IS 2006/03/22 REV:	QUALITY SYMBOLS ▽=0 ▽=0	GENERAL TOLERANCES (UNLESS SPECIFIED)		DIMENSION STYLE MM ONLY		SCALE 2:1	DESIGN UNITS METRIC	THIRD ANGLE PROJECTION			
		4 PLACES ± --- ± ---	DRAWN BY KLANG	DATE 02/09/05	TITLE I-PASS VERT CONNECTOR INTERNAL ASSY W/SHELL 0.8MM PITCH I/O						
		3 PLACES ± --- ± ---	CHECKED BY JSWENSON	DATE 02/09/05	MOLEX INCORPORATED						
		2 PLACES ± 0.13 ± ---	APPROVED BY MBANAK IS	DATE 02/02/05	MATERIAL NO.	DOCUMENT NO. SD-75784-001	SHEET NO. 4 OF 10				
1 PLACE ± 0.25 ± ---	ANGULAR ±1/2°		DRAFT WHERE APPLICABLE MUST REMAIN WITHIN DIMENSIONS		SEE CHART		THIS DRAWING CONTAINS INFORMATION THAT IS PROPRIETARY TO MOLEX INCORPORATED AND SHOULD NOT BE USED WITHOUT WRITTEN PERMISSION				

36 CIRCUIT ITEM NUMBERS

CIRCUIT SIZE	ITEM NUMBER	PLATING OPTION	SHELL PCB OPTION	SHELL KEY OPTION
36	75784-0107	OPTION 1	RETENTION	LEFT
36	75784-0108	OPTION 1	RETENTION	RIGHT
36	75784-0109	OPTION 1	RETENTION	DUAL
36	75784-0110	OPTION 1	SMT	LEFT
36	75784-0111	OPTION 1	SMT	RIGHT
36	75784-0112	OPTION 1	SMT	DUAL
36	75784-0119	OPTION 2	RETENTION	LEFT
36	75784-0120	OPTION 2	RETENTION	RIGHT
36	75784-0121	OPTION 2	RETENTION	DUAL
36	75784-0122	OPTION 2	SMT	LEFT
36	75784-0123	OPTION 2	SMT	RIGHT
36	75784-0124	OPTION 2	SMT	DUAL
36	75784-0125	OPTION 1	RETENTION	UNIVERSAL
36	75784-0126	OPTION 1	SMT	UNIVERSAL
36	75784-0127	OPTION 2	RETENTION	UNIVERSAL
36	75784-0128	OPTION 2	SMT	UNIVERSAL
36	75784-0129	OPTION 1	THRU HOLE	LEFT
36	75784-0130	OPTION 1	THRU HOLE	RIGHT
36	75784-0131	OPTION 1	THRU HOLE	DUAL
36	75784-0132	OPTION 1	THRU HOLE	UNIVERSAL
36	75784-0133	OPTION 2	THRU HOLE	LEFT
36	75784-0134	OPTION 2	THRU HOLE	RIGHT
36	75784-0135	OPTION 2	THRU HOLE	DUAL
36	75784-0136	OPTION 2	THRU HOLE	UNIVERSAL

CIRCUIT SIZE	ITEM NUMBER	PLATING OPTION	SHELL PCB OPTION	SHELL KEY OPTION
36	75784-0137	OPTION 1	T/H 2.79	LEFT
36	75784-0138	OPTION 1	T/H 2.79	RIGHT
36	75784-0139	OPTION 1	T/H 2.79	DUAL
36	75784-0140	OPTION 1	T/H 2.79	UNIVERSAL
36	75784-0141	OPTION 2	T/H 2.79	LEFT
36	75784-0142	OPTION 2	T/H 2.79	RIGHT
36	75784-0143	OPTION 2	T/H 2.79	DUAL
36	75784-0144	OPTION 2	T/H 2.79	UNIVERSAL
36	75784-0145	OPTION 1	T/H 3.18	LEFT
36	75784-0146	OPTION 1	T/H 3.18	RIGHT
36	75784-0147	OPTION 1	T/H 3.18	DUAL
36	75784-0148	OPTION 1	T/H 3.18	UNIVERSAL
36	75784-0149	OPTION 2	T/H 3.18	LEFT
36	75784-0150	OPTION 2	T/H 3.18	RIGHT
36	75784-0151	OPTION 2	T/H 3.18	DUAL
36	75784-0152	OPTION 2	T/H 3.18	UNIVERSAL
36	75784-0153	OPTION 1	T/H 3.56	LEFT
36	75784-0154	OPTION 1	T/H 3.56	RIGHT
36	75784-0155	OPTION 1	T/H 3.56	DUAL
36	75784-0156	OPTION 1	T/H 3.56	UNIVERSAL
36	75784-0157	OPTION 2	T/H 3.56	LEFT
36	75784-0158	OPTION 2	T/H 3.56	RIGHT
36	75784-0159	OPTION 2	T/H 3.56	DUAL
36	75784-0160	OPTION 2	T/H 3.56	UNIVERSAL

SEE SHEET 1 FCC NO: UCP2006-2031 DRAWN: J.SWENSON 2006/03/24 CHKD: MBANAKIS 2006/03/24 APPR: MBANAKIS 2006/03/22 REV: C1	QUALITY SYMBOLS ▽=0 ▽=0	GENERAL TOLERANCES (UNLESS SPECIFIED)		DIMENSION STYLE MM ONLY		SCALE 2:1	DESIGN UNITS METRIC	THIRD ANGLE PROJECTION		
		4 PLACES ±.005 ±.005	3 PLACES ±.005 ±.005	2 PLACES ±0.13 ±.005	1 PLACE ±0.25 ±.005	ANGULAR ±1/2°	DRAWN BY KLANG	DATE 02/09/05	CHECKED BY JSWENSON	DATE 02/09/05
		DRAFT WHERE APPLICABLE MUST REMAIN WITHIN DIMENSIONS		SEE CHART		MATERIAL NO. MBANAKIS	DATE 02/02/05	I-PASS VERT CONNECTOR INTERNAL ASSY W/SHELL 0.8MM PITCH I/O		
						MOLEX INCORPORATED		DOCUMENT NO. SD-75784-001	SHEET NO. 5 OF 10	

50 CIRCUIT ITEM NUMBERS

68 CIRCUIT ITEM NUMBERS

CIRCUIT SIZE	ITEM NUMBER	PLATING OPTION	SHELL PCB OPTION	SHELL KEY OPTION
50	75784-0207	OPTION 1	RETENTION	LEFT
50	75784-0208	OPTION 1	RETENTION	RIGHT
50	75784-0209	OPTION 1	RETENTION	DUAL
50	75784-0210	OPTION 1	SMT	LEFT
50	75784-0211	OPTION 1	SMT	RIGHT
50	75784-0212	OPTION 1	SMT	DUAL
50	75784-0219	OPTION 2	RETENTION	LEFT
50	75784-0220	OPTION 2	RETENTION	RIGHT
50	75784-0221	OPTION 2	RETENTION	DUAL
50	75784-0222	OPTION 2	SMT	LEFT
50	75784-0223	OPTION 2	SMT	RIGHT
50	75784-0224	OPTION 2	SMT	DUAL
50	75784-0225	OPTION 1	RETENTION	UNIVERSAL
50	75784-0226	OPTION 1	SMT	UNIVERSAL
50	75784-0227	OPTION 2	RETENTION	UNIVERSAL
50	75784-0228	OPTION 2	SMT	UNIVERSAL
50	75784-0229	OPTION 1	THRU HOLE	LEFT
50	75784-0230	OPTION 1	THRU HOLE	RIGHT
50	75784-0231	OPTION 1	THRU HOLE	DUAL
50	75784-0232	OPTION 1	THRU HOLE	UNIVERSAL
50	75784-0233	OPTION 2	THRU HOLE	LEFT
50	75784-0234	OPTION 2	THRU HOLE	RIGHT
50	75784-0235	OPTION 2	THRU HOLE	DUAL
50	75784-0236	OPTION 2	THRU HOLE	UNIVERSAL

CIRCUIT SIZE	ITEM NUMBER	PLATING OPTION	SHELL PCB OPTION	SHELL KEY OPTION
68	75784-0307	OPTION 1	RETENTION	LEFT
68	75784-0308	OPTION 1	RETENTION	RIGHT
68	75784-0309	OPTION 1	RETENTION	DUAL
68	75784-0310	OPTION 1	SMT	LEFT
68	75784-0311	OPTION 1	SMT	RIGHT
68	75784-0312	OPTION 1	SMT	DUAL
68	75784-0319	OPTION 2	RETENTION	LEFT
68	75784-0320	OPTION 2	RETENTION	RIGHT
68	75784-0321	OPTION 2	RETENTION	DUAL
68	75784-0322	OPTION 2	SMT	LEFT
68	75784-0323	OPTION 2	SMT	RIGHT
68	75784-0324	OPTION 2	SMT	DUAL
68	75784-0325	OPTION 1	RETENTION	UNIVERSAL
68	75784-0326	OPTION 1	SMT	UNIVERSAL
68	75784-0327	OPTION 2	RETENTION	UNIVERSAL
68	75784-0328	OPTION 2	SMT	UNIVERSAL
68	75784-0329	OPTION 1	THRU HOLE	LEFT
68	75784-0330	OPTION 1	THRU HOLE	RIGHT
68	75784-0331	OPTION 1	THRU HOLE	DUAL
68	75784-0332	OPTION 1	THRU HOLE	UNIVERSAL
68	75784-0333	OPTION 2	THRU HOLE	LEFT
68	75784-0334	OPTION 2	THRU HOLE	RIGHT
68	75784-0335	OPTION 2	THRU HOLE	DUAL
68	75784-0336	OPTION 2	THRU HOLE	UNIVERSAL

NOTE:

1. PACKAGING CONSISTS OF CONNECTOR AND SHELL WITH A PRE-POSITIONING PICK AND PLACE DEVICE THAT ARE PACKAGED IN "TAPE AND REEL" FOR ROBOTIC PICK AND PLACE.

iPass IS A TRADEMARK OF MOLEX

SEE SHEET 1 FC NO: UCP2006-2031 DRAWN: J.SWENSON 2006/03/24 CHKD: 2006/03/24 APPR: MBANAK IS 2006/03/22 REV: C1	QUALITY SYMBOLS ▽=0 ▽=0	GENERAL TOLERANCES (UNLESS SPECIFIED)		DIMENSION STYLE MM ONLY		SCALE 2:1	DESIGN UNITS METRIC	THIRD ANGLE PROJECTION	
		mm INCH		DRAWN BY DATE KLANG 02/09/05		TITLE I-PASS VERT CONNECTOR INTERNAL ASSY W/SHELL 0.8MM PITCH I/O			
		4 PLACES ± --- ± --- 3 PLACES ± --- ± --- 2 PLACES ± 0.13 ± --- 1 PLACE ± 0.25 ± ---		CHECKED BY DATE JSWENSON 02/09/05		MOLEX INCORPORATED			
		ANGULAR ±1/2°		APPROVED BY DATE MBANAK IS 02/02/05		MATERIAL NO. SEE CHART		DOCUMENT NO. SD-75784-001	
DRAFT WHERE APPLICABLE MUST REMAIN WITHIN DIMENSIONS				THIS DRAWING CONTAINS INFORMATION THAT IS PROPRIETARY TO MOLEX INCORPORATED AND SHOULD NOT BE USED WITHOUT WRITTEN PERMISSION					

VERTICAL CONNECTOR WITH RETENTION FIT & THRU-HOLE SHELL PCB FOOT PRINT

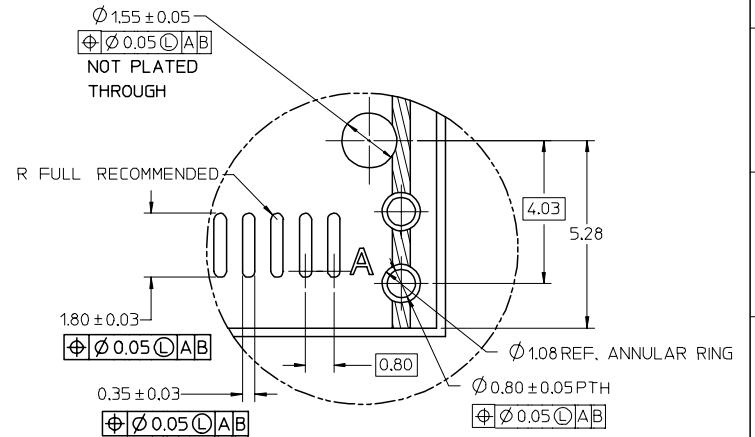
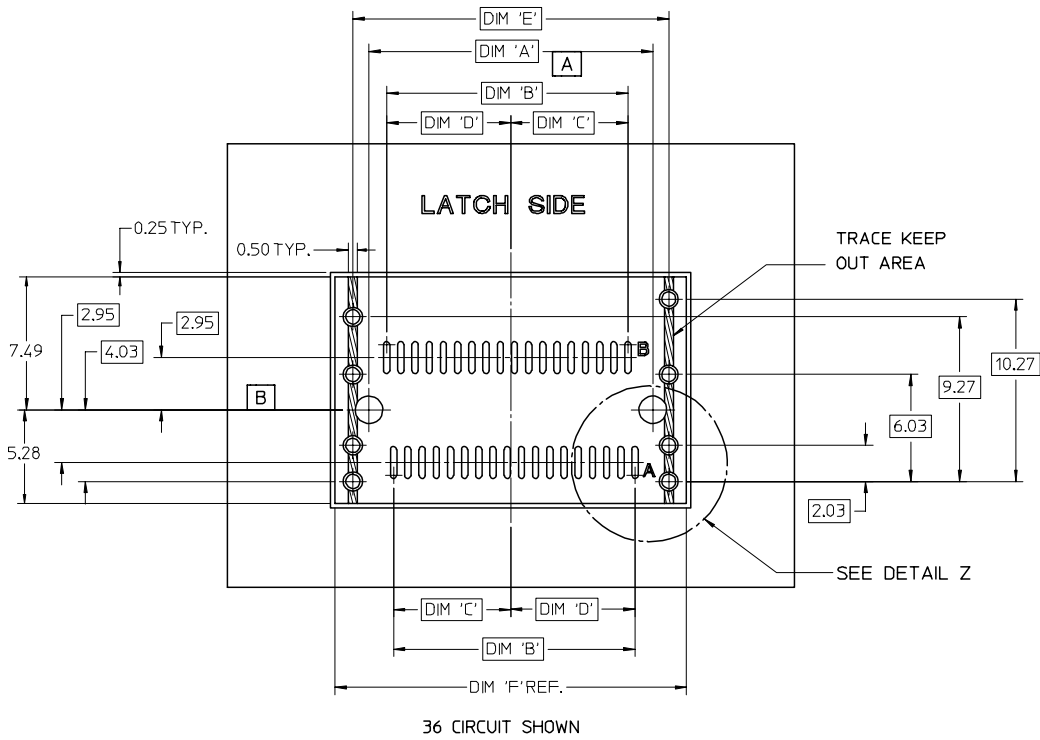

CIRCUIT SIZE	DIMENSIONS					
	DIM 'A'	DIM 'B'	DIM 'C'	DIM 'D'	DIM 'E'	DIM 'F'
26	12.00	9.60	4.60	5.00	13.80	15.80
36	16.00	13.60	6.60	7.00	17.80	19.80
50	21.60	19.20	9.40	9.80	23.40	25.40
68	28.80	26.40	13.00	13.40	30.60	32.60

SEE SHEET 1 FC NO: UCP2006-2031 DRAWN: J.SWENSON 2006/03/21 CHKD: 2006/03/21 APPR: MBANAKIS 2006/03/22	QUALITY SYMBOLS ▽=0 ▽=0	GENERAL TOLERANCES (UNLESS SPECIFIED)		DIMENSION STYLE MM ONLY		SCALE 5:1	DESIGN UNITS METRIC	THIRD ANGLE PROJECTION	
		4 PLACES ± --- ± --- 3 PLACES ± --- ± --- 2 PLACES ± 0.13 ± --- 1 PLACE ± 0.25 ± ---	mm INCH	DRAWN BY KLANG	DATE 02/09/05	TITLE I-PASS VERT CONNECTOR INTERNAL ASSY W/SHELL 0.8MM PITCH I/O			
		ANGULAR ±1/2°		CHECKED BY JSWENSON	DATE 02/09/05	APPROVED BY MBANAKIS			
		DRAFT WHERE APPLICABLE MUST REMAIN WITHIN DIMENSIONS		MATERIAL NO. SEE CHART	DATE 02/02/05	MOLEX INCORPORATED		DOCUMENT NO. SD-75784-001	SHEET NO. 7 OF 10

VERTICAL CONNECTOR WITH SMT SHELL PCB FOOT PRINT

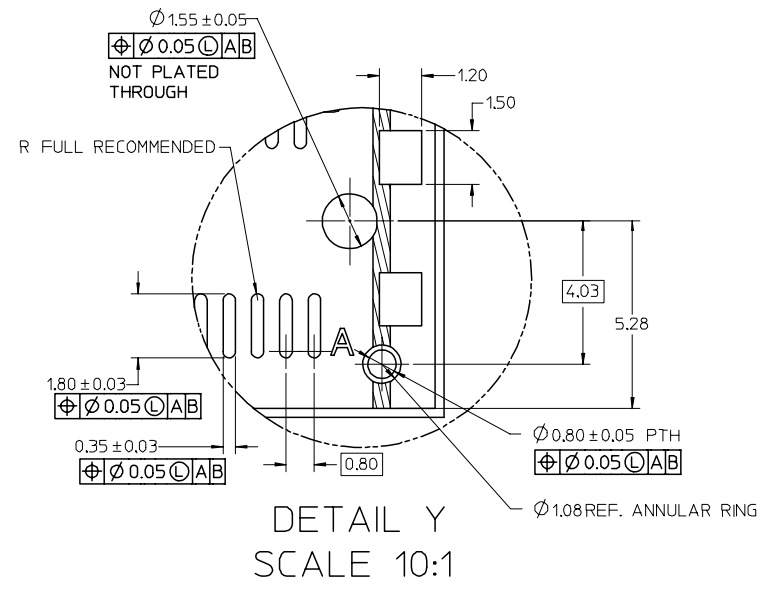
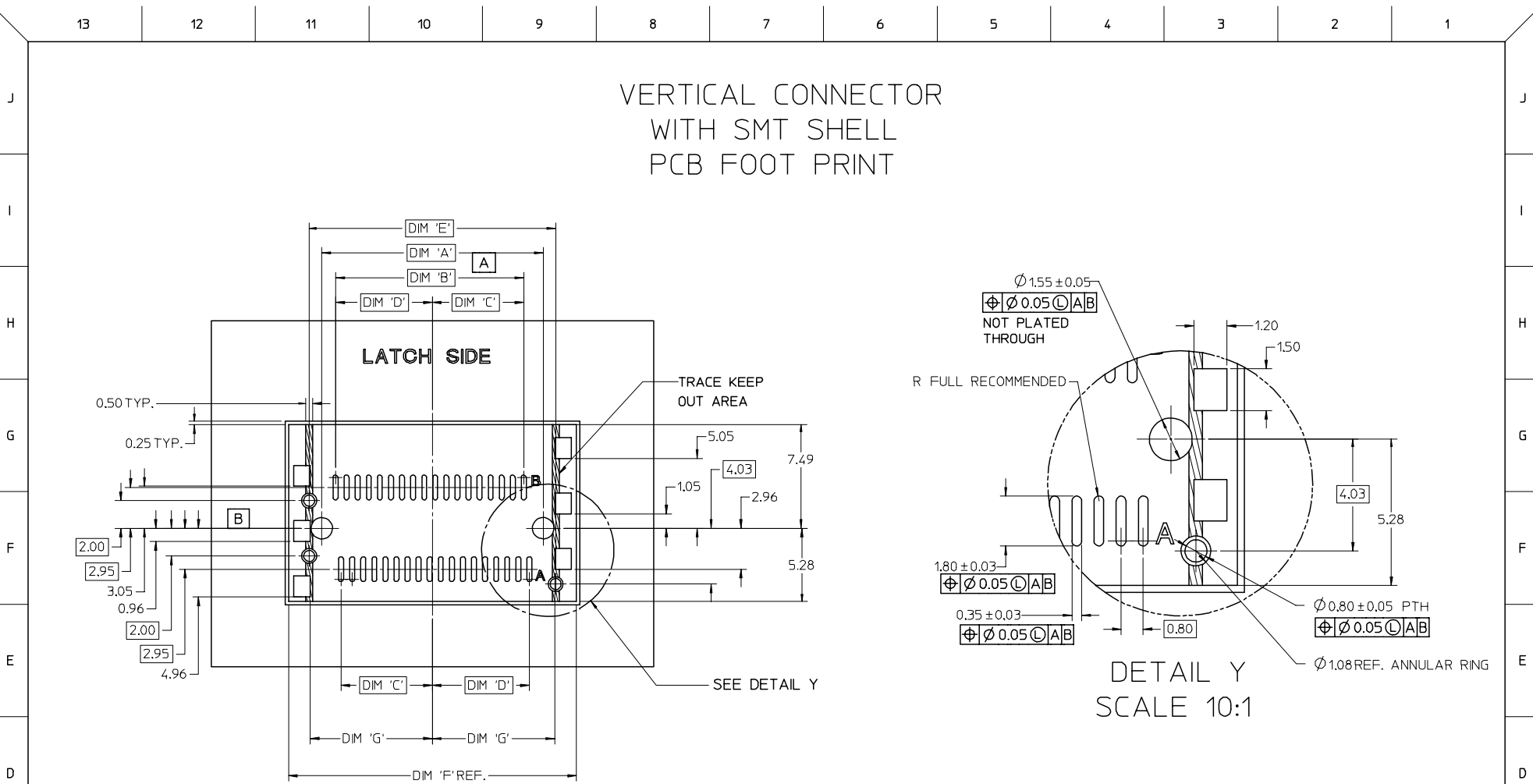

36 CIRCUIT SHOWN

CIRCUIT SIZE	PCB FOOTPRINT DIMENSIONS						
	PEG TO PEG	FIRST TO LAST PAD	CENTERLINE TO PAD	CENTERLINE TO PAD	SHELL PEG TO PEG	SHELL FOOTPRINT WIDTH	CENTERLINE TO PAD EDGE
	DIM 'A'	DIM 'B'	DIM 'C'	DIM 'D'	DIM 'E'	DIM 'F'	DIM 'G'
26	12.00	9.60	4.60	5.00	13.80	16.80	6.825
36	16.00	13.60	6.60	7.00	17.80	20.80	8.825
50	21.60	19.20	9.40	9.80	23.40	26.40	11.625
68	28.80	26.40	13.00	13.40	30.60	33.60	15.225

SEE SHEET 1 FC NO: UICP2006-2031 DRAWN: J.SWENSON 2006/03/24 CHKD: 2006/03/24 APPR: MBANAKIS 2006/03/22 REV: C1	QUALITY SYMBOLS ▽=0 ▽=0	GENERAL TOLERANCES (UNLESS SPECIFIED)		DIMENSION STYLE MM ONLY		SCALE 5:1	DESIGN UNITS METRIC	THIRD ANGLE PROJECTION		
		4 PLACES ± --- ± --- 3 PLACES ± --- ± --- 2 PLACES ± 0.13 ± --- 1 PLACE ± 0.25 ± --- ANGULAR ± 1/2°	mm INCH	DRAWN BY: KLANG CHECKED BY: JSWENSON APPROVED BY: MBANAKIS MATERIAL NO.	DATE: 02/09/05 DATE: 02/09/05 DATE: 02/02/05	TITLE I-PASS VERT CONNECTOR INTERNAL ASSY W/SHELL 0.8MM PITCH I/O				
		DRAFT WHERE APPLICABLE MUST REMAIN WITHIN DIMENSIONS		SEE CHART		MOLEX INCORPORATED		DOCUMENT NO. SD-75784-001		SHEET NO. 8 OF 10
		THIS DRAWING CONTAINS INFORMATION THAT IS PROPRIETARY TO MOLEX INCORPORATED AND SHOULD NOT BE USED WITHOUT WRITTEN PERMISSION								

iPass™ IS A TRADEMARK OF MOLEX

VERTICAL CONNECTOR WITH SHELL PCB FOOT PRINT DESCRIPTIONS

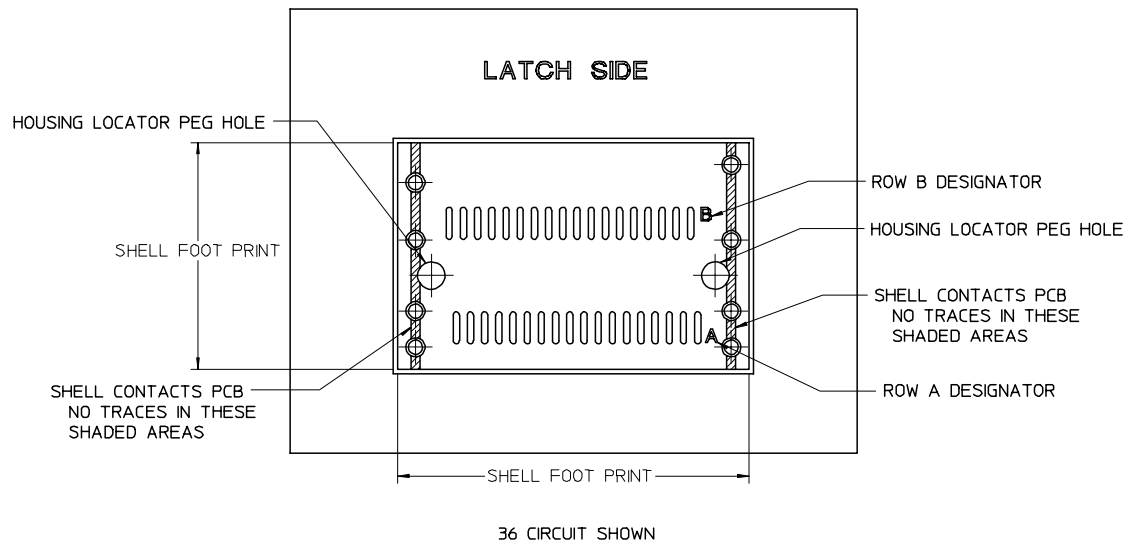

iPass™ IS A TRADEMARK OF MOLEX

ENTER DESCRIPTION EC NO: UCP2006-2031 DRAWN: J.SWENSON 2006/03/21 CHKD: 2006/03/21 APPR: MBANAKIS 2006/03/22 REVISIONS C1	QUALITY SYMBOLS =0 =0	GENERAL TOLERANCES (UNLESS SPECIFIED)		DIMENSION STYLE MM ONLY		SCALE 5:1	DESIGN UNITS METRIC	THIRD ANGLE PROJECTION		
		mm	INCH	DRAWN BY KLANG	DATE 02/09/05	TITLE I-PASS VERT CONNECTOR INTERNAL ASSY W/SHELL 0.8MM PITCH I/O				
		4 PLACES ± .005	± .005	CHECKED BY JSWENSON	DATE 02/09/05					
		3 PLACES ± .005	± .005	APPROVED BY MBANAKIS	DATE 02/02/05	MATERIAL NO. SD-75784-001		DOCUMENT NO. SD-75784-001		SHEET NO. 9 OF 10
2 PLACES ± 0.13	± .013	DRAFT WHERE APPLICABLE MUST REMAIN WITHIN DIMENSIONS		SEE CHART						
1 PLACE ± 0.25	± .025	THIS DRAWING CONTAINS INFORMATION THAT IS PROPRIETARY TO MOLEX INCORPORATED AND SHOULD NOT BE USED WITHOUT WRITTEN PERMISSION								
ANGULAR ±1/2°										