

PROPER USE GUIDELINES

Cumulative Trauma Disorders can result from the prolonged use of manually powered hand tools. AMP hand tools are intended for occasional use and low volume applications. AMP offers a wide selection of powered application equipment for extended-use, production operations.

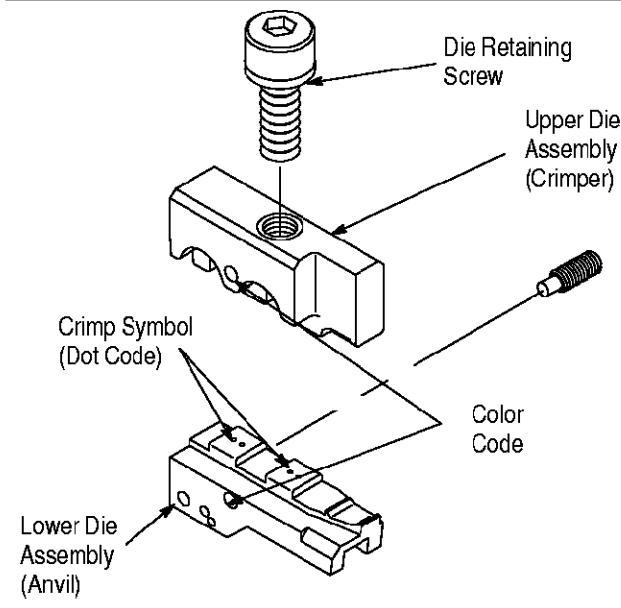

Figure 1

1. INTRODUCTION

AMP* Platform Crimping Die Assemblies 90390-3 and 90391-3 are used in AMP Platform Hand Tool Frame 58078-3 (408-6976). The die assemblies crimp the Ultra-Fast Fully Insulated FASTON* Terminals listed in Figure 2. Read These instructions before using the Platform Hand Tool Frame and Platform Crimping Dies.

NOTE *Dimensions are in millimeters [with inch equivalents in brackets]. Figures are for identification only and are not drawn to scale.*

Reasons for reissue are provided in Section 7, REVISION SUMMARY.

2. DESCRIPTION

Each die assembly consists of an upper die (crimper) and a lower die (anvil), a retaining screw (on the upper die), and a hex wrench for securing the lower die to the platform of the hand tool frame.

The die assemblies are identified by part numbers, color dot codes, and applicable wire range designations. See Figure 1. The 90390-3 die assembly has a red color dot on both the crimper and the anvil, while the 90391-3 die assembly has a blue

color dot on the crimper and the anvil. The color coding on the die assembly corresponds to the color coding on translucent insulation of the Ultra-Fast FASTON terminal for easier identification when crimping.

3. INSTALLATION

Determine the part number of the terminal you are crimping, then refer to the table in Figure 2 and select the appropriate die assembly. Install dies as described below.

3.1. Installing Lower Die Assembly

1. Squeeze the tool handlers together until they bottom. Then allow them to open fully.
2. Hold the hand tool frame so that the back of the tool is facing you and note the socket head screw located in the lower die platform. See Figure 3.
3. Slide the lower die onto the lower platform, ensuring that the drilled holes on the side of the lower die line up with the socket head screw.

NOTE *If the lower die will not seat on the lower die platform with the drilled hole aligned with the socket head screw, use the hex wrench to turn the screw either in or out until the lower die is correctly positioned.*

4. With the lower die in place, turn the socket head screw (on the die platform) clockwise until snug. Do NOT overtighten.

3.2. Installing Upper Die Assembly

1. Remove the die retaining screw from the die assembly.
2. Position the upper die in upper die platform of the tool. Thread the die retaining screw through the mounting hole in the top of tool and tighten the screw until it is snug but NOT secured.
3. While guiding the upper die into alignment with the lower die, slowly close the tool handles until the dies bottom.
4. Tighten the upper die retaining screw until the die is secure.
5. Squeeze the tool handles together until the ratchet releases. Allow the tool handles to open fully. The tool is now ready for use.

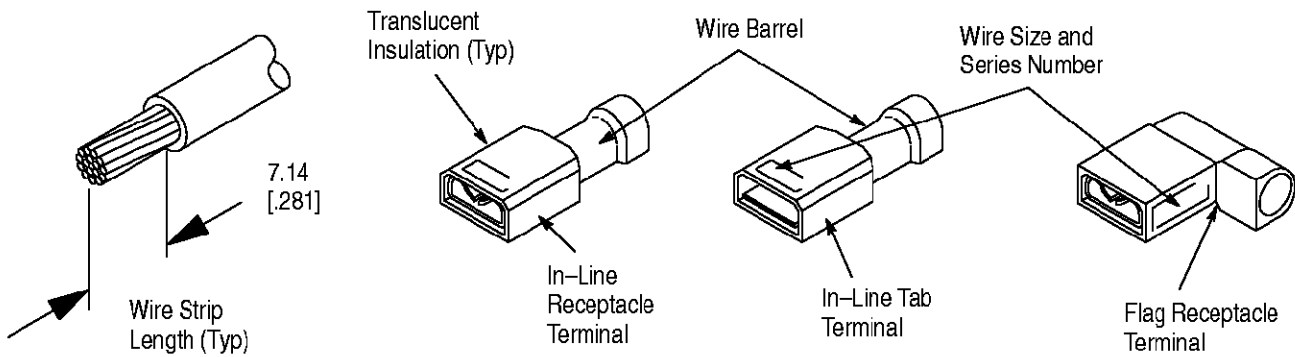

WIRE		TERMINAL					DIE	
WIRE SIZE (AWG)	INSUL DIA (Max)	SERIES	TYPE	COLOR CODE	LP	STRIP	DIE NUMBER	CRIMP SYMBOL (Dot Code)
22-16	3.04 [.120]	110	In-Line Recpt	Red	520081	520080	90390-3	1 Dot
	3.04 [.120]	110	In-Line Recpt		520084	520083		1 Dot
	3.04 [.120]	110	In-Line Recpt		520273	520272		1 Dot
	5.84 [.230]	110	In-Line Recpt		—	520306		1 Dot
	3.43 [.135]	187	In-Line Recpt		520182	520181		1 Dot
	3.43 [.135]	187	In-Line Recpt		520194	520193		1 Dot
	4.19 [.165]	187	Flag Recpt		520335	520334		Plain (No Mark)
	4.19 [.165]	187	Flag Recpt		520337	520336		Plain (No Mark)
	5.84 [.230]	187	In-Line Recpt		—	52061		1 Dot
	5.84 [.230]	187	In-Line Recpt		520275	520274		1 Dot
	3.43 [.135]	250	In-Line Recpt		520184	520183		1 Dot
	5.84 [.230]	250	In-Line Recpt		520264	520263		1 Dot
	3.43 [.135]	250	In-Line Tab		520103	520102		1 Dot
	4.19 [.165]	250	Flag Recpt		520129	520128		Plain (No Mark)
16-14	6.60 [.260]	110	In-Line Recpt	Blue	—	520370	90391-3	2 Dots
	4.06 [.160]	187	In-Line Recpt		350816	350815		2 Dots
	4.06 [.160]	187	In-Line Recpt		520125	520124		2 Dots
	4.70 [.185]	187	Flag Recpt		520339	—		Plain (No Mark)
	4.70 [.185]	187	Flag Recpt		—	520340		Plain (No Mark)
	6.60 [.260]	187	In-Line Recpt		520151	520150		2 Dots
	4.06 [.160]	187	In-Line Recpt		350820	350819		2 Dots
	4.06 [.160]	250	In-Line Recpt		520117	520116		2 Dots
	6.60 [.260]	250	In-Line Recpt		520141	520140		2 Dots
	4.06 [.160]	250	In-Line Tab		520107	520106		2 Dots
	4.70 [.185]	250	Flag Recpt		520133	520132		Plain (No Mark)
	4.19 [.165]	250	Flag Recpt		520129	520128		Plain (No Mark)
	5.84 [.230]	250	Flag Recpt		—	520856		Plain (No Mark)

Figure 2

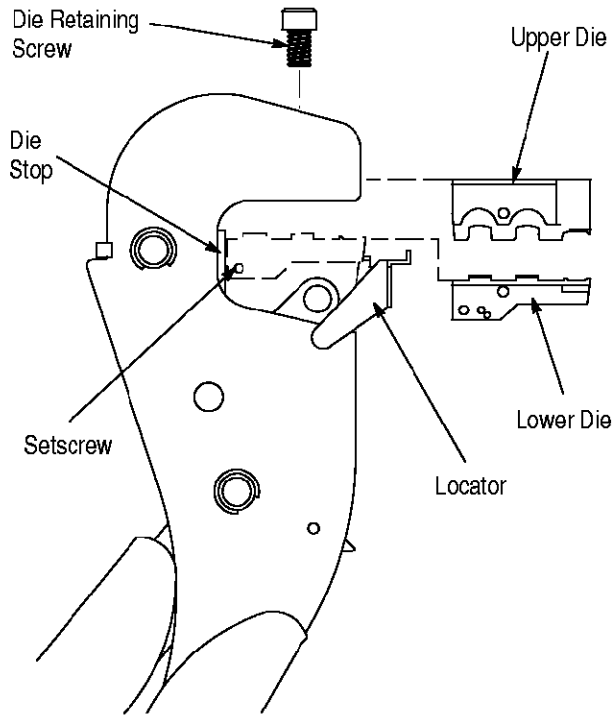

Figure 3

4. CRIMPING PROCEDURE

1. Refer to the table in Figure 2, select a wire of the specified size and strip the wire to the dimension provided. Do NOT nick or cut the wire strands.
2. Select an applicable contact. See Figure 2.
3. Hold the tool so that the front of the tool is facing you.
4. Make sure that the ratchet is released. Squeeze the tool handles together and allow them to open fully.
5. Rotate the blue plastic locator stop index to the appropriate position.
 - When crimping a 110 series terminal, rotate the index until the number “110” appears in the uppermost position.
 - When crimping a 187 or 250 series terminal, rotate the index until the numbers “250-187” appear in the uppermost position.
6. Insert the terminal into the proper crimp section. In-line terminals may be crimped in either in-line section. Flag terminals must be crimped in the flag crimp section. See Figure 4.
 - For in-line terminals, the flat side of the terminal must seat on the locator.

- For flag terminals, the flat side of the wire end must face outward and the mating end must seat on the locator.
7. Squeeze the tool handles sufficiently to hold the terminal firmly in place without deforming it.
 8. Insert a properly stripped wire into the barrel of the terminal.
 9. Hold the wire in place and squeeze the tool handles until the ratchet releases.
 10. Allow the tool handles to open fully, and remove the crimped terminal.

5. MAINTENANCE/INSPECTION

5.1. Daily Maintenance

Remove all foreign particles with a clean, soft brush or a clean, soft, lint-free cloth. Do NOT use materials or objects that can damage the dies. If foreign matter cannot be removed easily, or if the proper replacement parts are not available, return the dies to your supervisor.

Make certain the dies are protected with a THIN coat of any good SAE 20 motor oil. DO NOT OIL EXCESSIVELY.

When the dies are not in use, mate and store them in a clean, dry area.

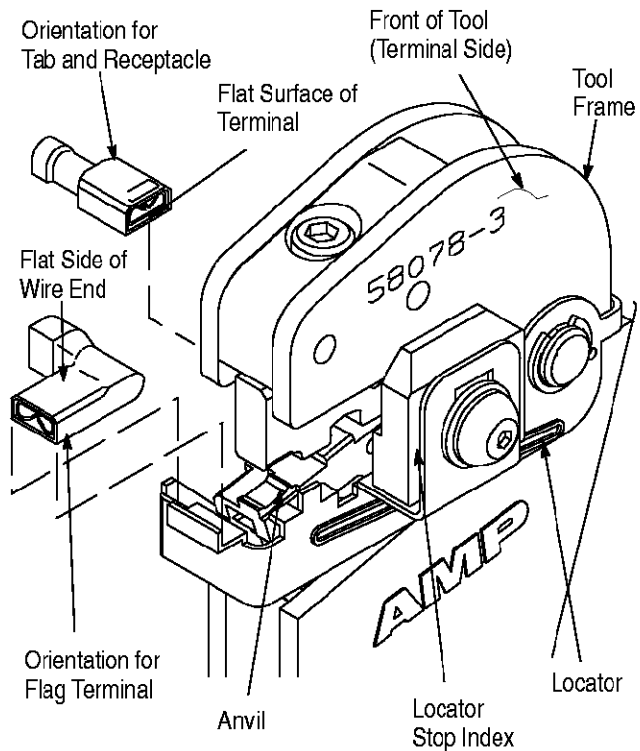

Figure 4

5.2. Periodic Inspection

Regular inspection should be performed by quality control personnel. A record of scheduled inspections should remain with the tool and/or be supplied to the supervisory personnel responsible for the tool. Though recommendations call for at least one inspection a month, the inspection frequency should be based on the amount of use, ambient working conditions, operator training and skill, and established company standards. These inspections should be performed in the following sequence:

A. Visual Inspection

1. Remove all lubrication and accumulated film by immersing the dies in a suitable degreaser that will not affect paint or plastic material.
2. Make sure all die holding screws and die components are in place. Refer to parts listed in Figure 6 if replacements are necessary.
3. Check all bearing surfaces. Remove and replace worn components.
4. Inspect the crimp area for flattened, chipped, cracked, worn or broken areas. If damage is evident, the dies must be repaired before returning them to service. Refer to Section 6, REPAIR.

If the crimping chamber conforms to the gage inspection, the dies are considered dimensionally correct and should be lubricated with a THIN coat of SAE 20 motor oil. If not, the dies must be repaired before returning them to service.

For additional information concerning the use of a plug gage, refer to AMP Instruction Sheet 408-7424.

Suggested Plug Gage Design

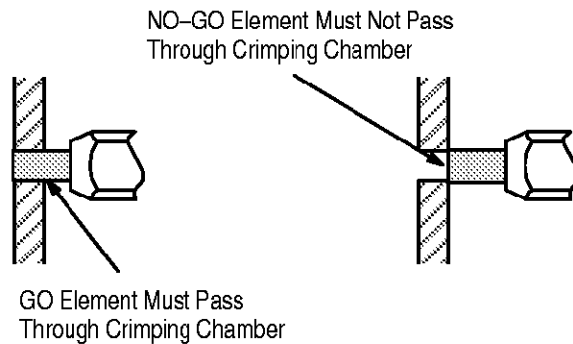
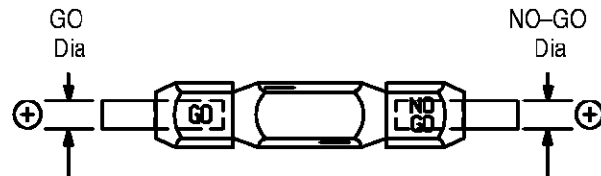

5.3. Gaging the Crimping Chamber

This inspection requires the use of a plug gage conforming to the diameters in Figure 5. AMP does not manufacture or market these gages.

Proceed as follows:

1. Mate the dies until it is evident that they have bottomed. Hold the dies in this position with a pressure of approximately 69 kPa [10 psi].
2. Align the GO element with the wire barrel crimping chamber. Push element straight into the crimping chamber without using force. The GO element must pass completely through the crimping chamber as shown in Figure 5.
3. Align the NO-GO element and try to insert it straight into the same crimping chamber. The NO-GO element may start entry but must not pass completely through, as shown in Figure 5.

Platform Die Number	Terminal Number (LP)	Element Diameter	
		GO	NO-GO
90390-3	520081	1.57 [.062]	1.73 [.068]
	520084		
	520273		
	520182		
	520194		
	520275		
	520184		
	520264		
	520103		
	520129		
	520335		
520337			
90391-3	350616	1.83 [.072]	1.98 [.078]
	520125		
	520151		
	350820		
	520117		
	520107		
	520141		
	520133		
	520339		

Figure 5

6. REPLACEMENT AND REPAIR

The parts listed in Figure 6 are customer-replaceable. A complete inventory can be stocked and controlled to prevent lost time when replacement of parts is necessary. Order replacement parts through your AMP representative, or call 1-800-526-5142, or send a facsimile of your purchase order to 1-717-986-7605, or write to:

CUSTOMER SERVICE (38-35)
 AMP INCORPORATED
 P.O. BOX 3608
 HARRISBURG, PA 17105-3608

Dies may be returned to AMP for evaluation and repair. For tool repair service, contact an AMP representative at 1-800-526-5136.

7. REVISION SUMMARY

The following changes were made since the previous release of this sheet:

Per EC 0990-0984-99

- Changed tool repair service information in Section 6, REPLACEMENT AND REPAIR
- Removed obsolete product part numbers
- Revised the title
- Updated document format

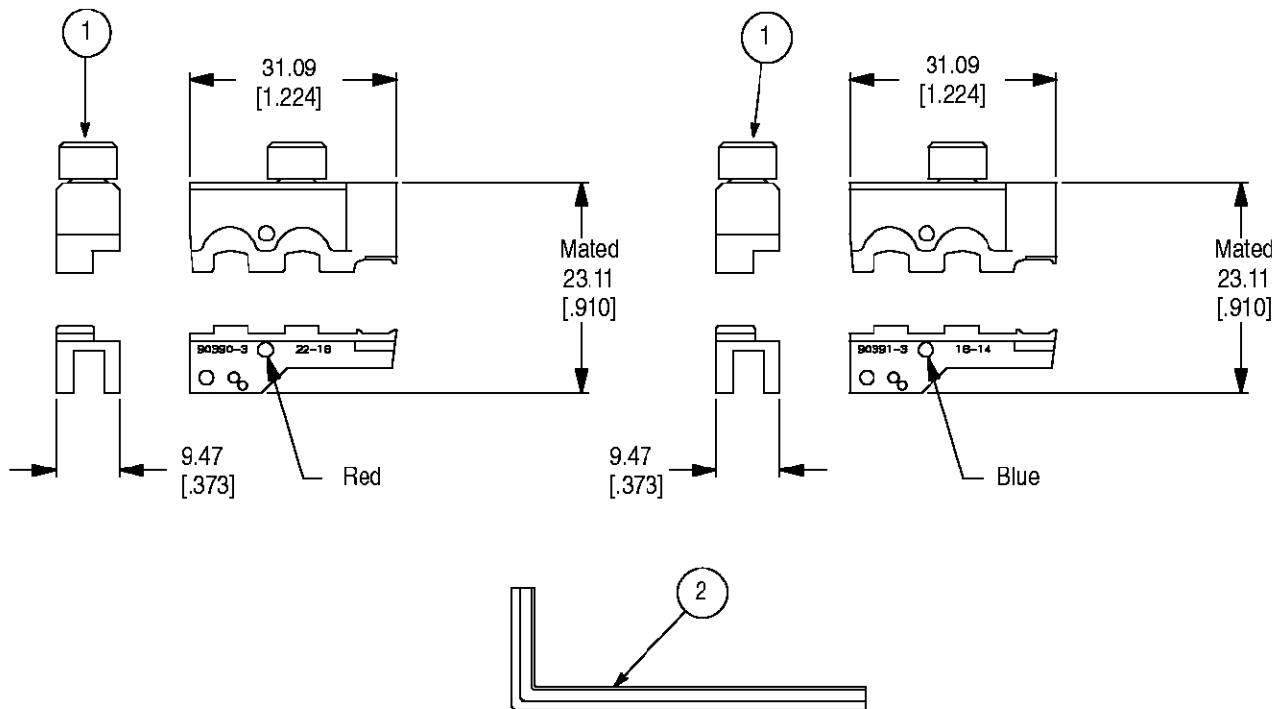

REPLACEMENT PARTS

ITEM NO.	PART NUMBER	DESCRIPTION	QTY PER DIE
1	3-21000-4	SCREW, Skt Hd Cap, 10-32 x .375 In. L	1
2	21027-3	WRENCH, Hex, .050 In.	1

Figure 6