

Extrusion

Milling, Drilling, Printing.
Modified Enclosures Supplied Quickly and Accurately.
Consult factory for Price and Delivery.

3D Models for product design in STEP and Iges Available
Consult Factory.

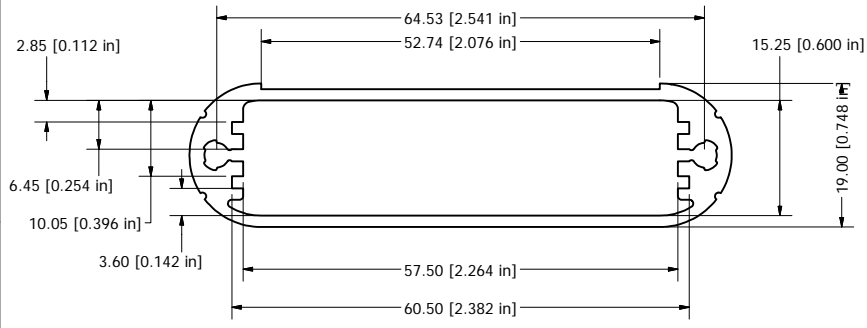

Extrusion designed for 60mm wide x 120mm long PCBs.

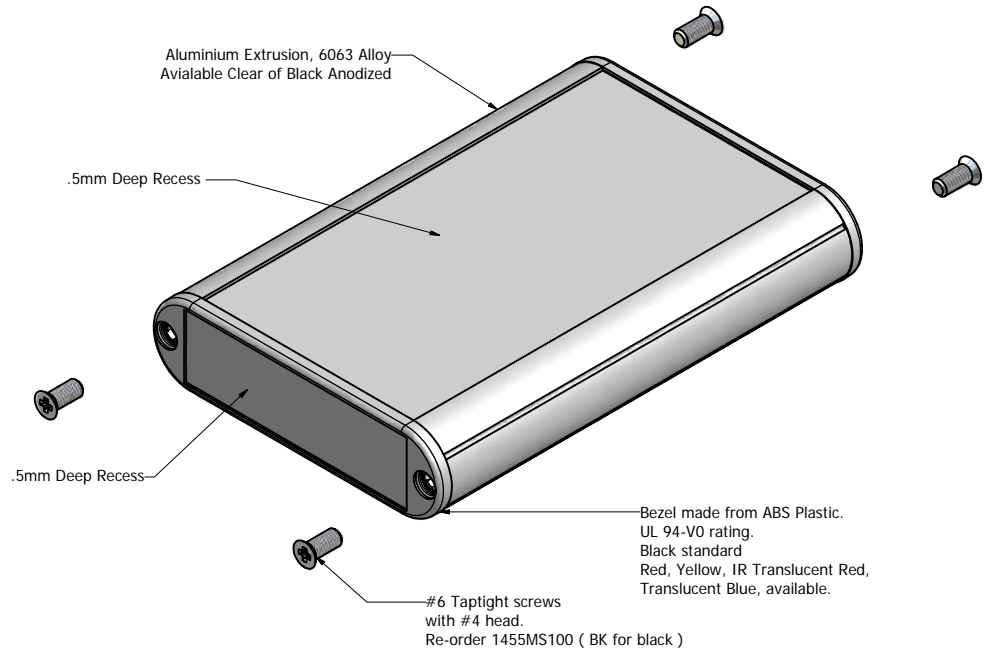
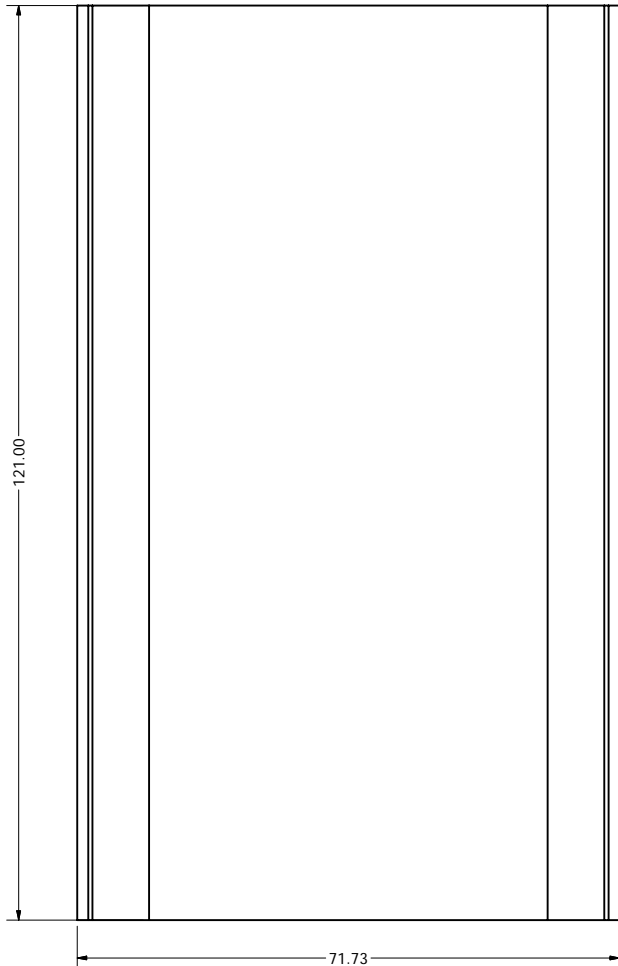

Bezel

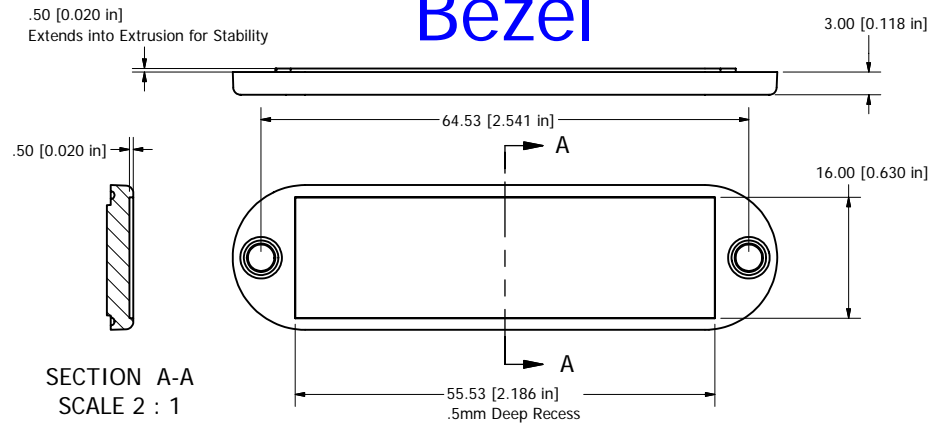

SECTION A-A
SCALE 2 : 1

HAMMOND MANUFACTURING™
1455B1202
www.hammondmfg.com