

<h1 style="margin: 0;">SPECIFICATION</h1> <p style="margin: 0;">MODEL : SLSNNWH802TS</p>
--

[Approved Rank : V_F(S), λ_b(S, L), I_v(D1, D2, D3, D4)]

WHITE TOP VIEW

CUSTOMER :

SAMSUNG ELECTRO-MECHANICS		
DRAWN	CHECKED	APPROVED

Preliminary

CUSTOMER :		
DRAWN	CHECKED	APPROVED

SAMSUNG ELECTRO-MECHANICS CO., LTD.
 314. MAETAN3-DONG, YEONGTONG-KU,
 SUWON-SI, GYUNGKI-DO, KOREA, 442-743

Contents

1. Product outline-----	3
2. Absolute Maximum Rating-----	3
3. Characteristics -----	3
4. Chromaticity Diagram -----	5
5. Typical Characteristic Graph -----	6
6. Outline Drawing and Dimension -----	7
7. Reliability Test Items and Conditions ---	8
8. Solder Conditions -----	9
9. Taping Dimension -----	10
10. Label Structure -----	11
11. Lot Number -----	11
12. Reel Packing Structure -----	12
13. Aluminum Vinyl Bag-----	13
14. Precaution for Use -----	14
15. Hazard Substance Analysis-----	16
16. Revision History -----	19

1. Product Outline

1) Feature

- . Lead Frame Type LED Package (3.5 * 2.8 * t 1.9mm)
- . Beam Angle ($\Delta\theta$: 120 °)
- . GaN/Al₂O₃ Chip & Long Time Reliability

2) Applications

- . Indoor, Outdoor Display and etc.

2. Absolute Maximum Rating

- 1). Operation Forward Current Per Chip..... 25 mA
 - 2). Peak Pulsed Forward Current Per Chip..... 100 mA
(Duty 1/10 Pulse Width 10msec)
 - 3). Reverse Current..... 85 mA
 - 4). Operating Temperature Range (T_{opr}) -30°C ~ 85°C
 - 5). Storage Temperature Range (T_{stg}) -40°C ~ 100°C
- . I_{FP} Conditions : Duty 1/10 Pulse Width 10msec

3. Characteristics

Electrical properties

(Ta : 25°C)

Item	Symbol	Conditions	Rank	Min.	Typ.	Max.	Unit
Forward Voltage (*)	V _F	I _F = 20 mA	S	2.9	-	3.6	V
Reverse Voltage	V _r	I _R = 10mA	-	0.6	-	2.0	V

Chromaticity

(Ta : 25°C)

Coordinate	Condition	Rank	x				y			
Chromaticity Coordinate(*)	IF=20mA	S	0.2805	0.2995	0.2910	0.2655	0.2465	0.2849	0.3100	0.2650
		L	0.2995	0.3200	0.3155	0.2910	0.2849	0.3255	0.3540	0.3100

Luminous Intensity

(Ta : 25°C)

Item	Symbol	Condition	Rank	Min.	Typ.	Max.	Unit	
Luminous Intensity (*)	I _v	I _F = 20 mA	D	D1	700	-	900	mcd
				D2	900	-	1200	
				D3	1200	-	1600	
				D4	1600	-	2100	

4. Chromaticity Diagram

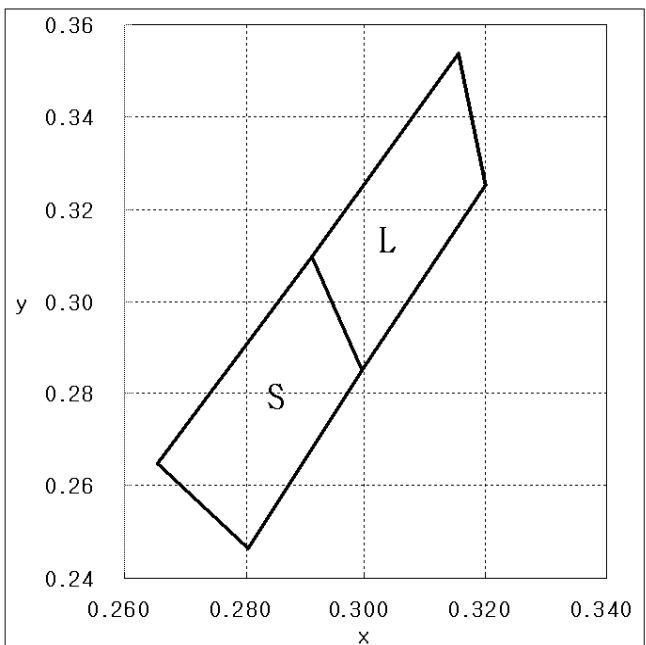
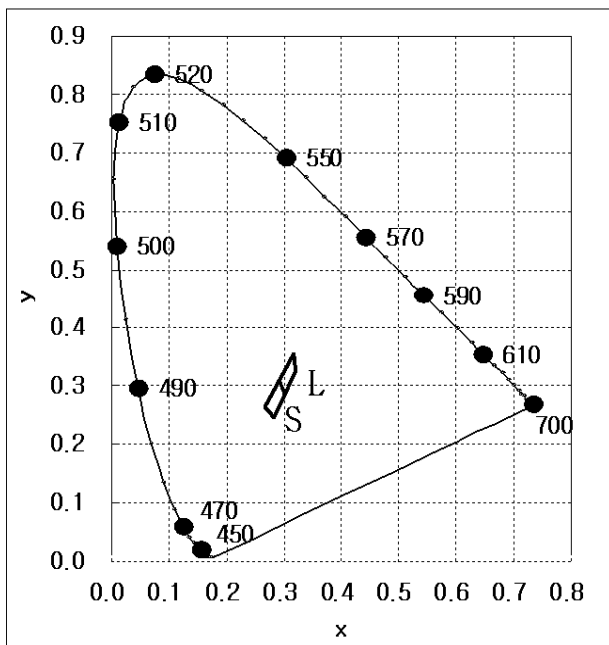

※ Approved Rank

V_F	CIE	I_v
S	S, L	D1, D2, D3, D4

- * Each reel contains only one of the S or L a segment (1/2) of the CIE rank.
- * Each reel contains only one of the D1, D2, D3 or D4 a segment (1/4) of the D rank.

5. Typical Characteristics Graph

* These graphs show typical values.

(Ta : 25°C)

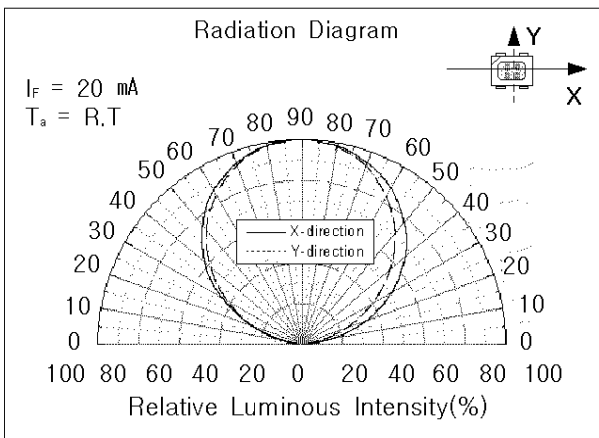
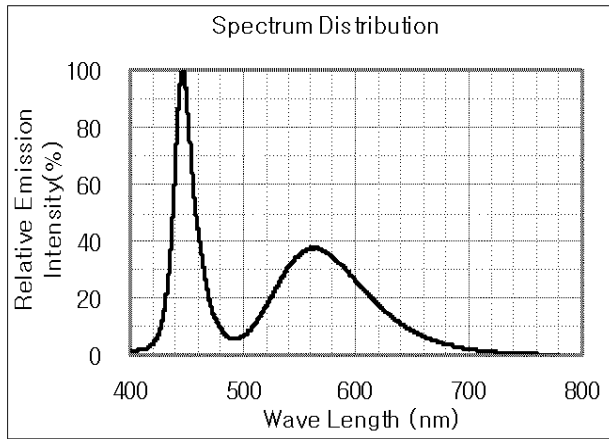
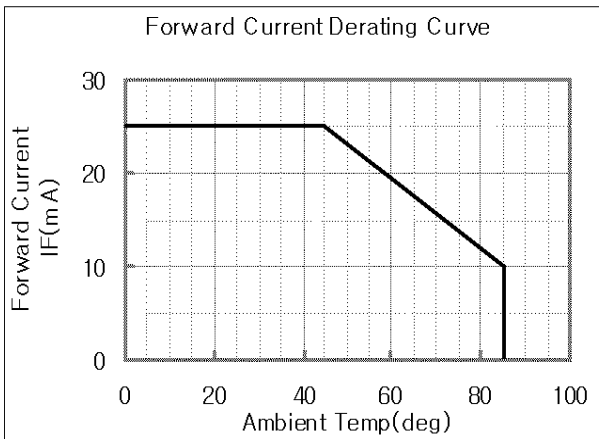
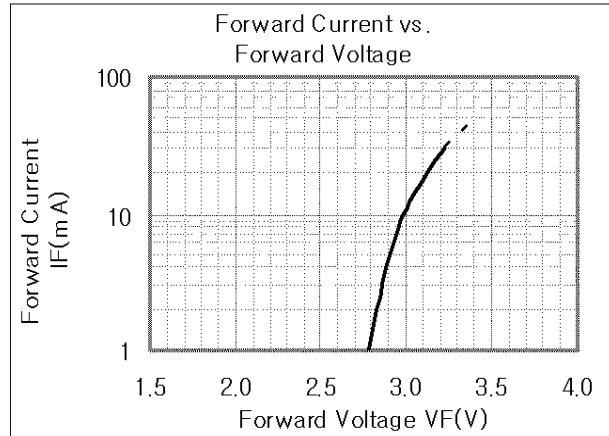
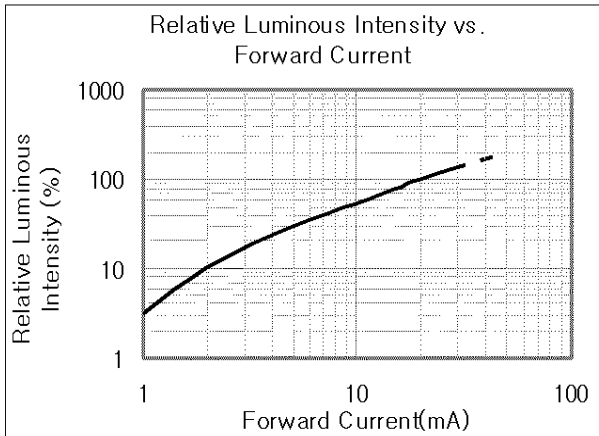

6. LED Package Outline Dimensions

Unit:mm

Tolerance:±0.1

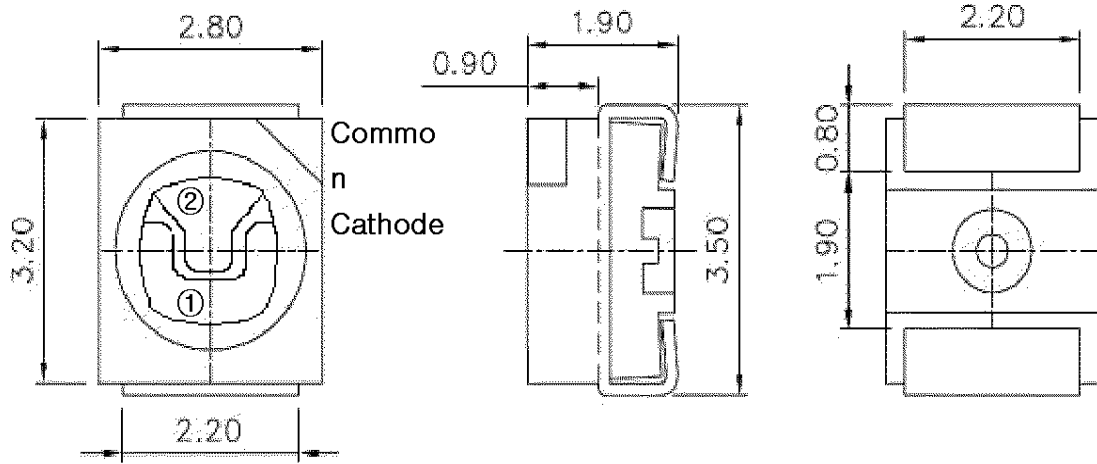

Cathode

②

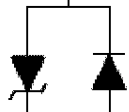

Anode

Circuit Diagram

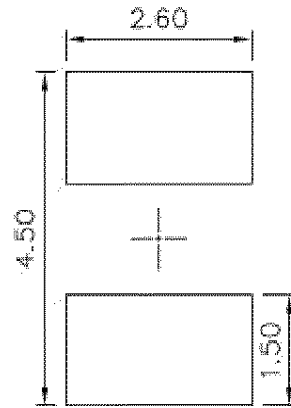

Land Pattern

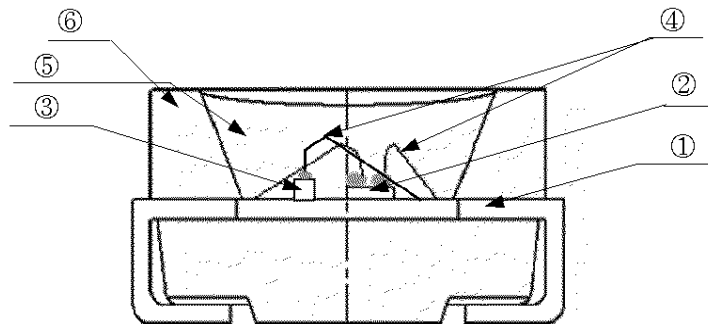

NUMBER	ITEM	MATERIAL
①	FRAME	Copper Frame(Silver Plated)
②	LED CHIP	GaN/Al ₂ O ₃
③	Zener Diode	Si
④	WIRE	Gold Wire
⑤	RESIN	Resin
⑥	PACKAGE	Heat-resistant Polymer

7. Reliability Test Items and Conditions

1) Test Items and Results

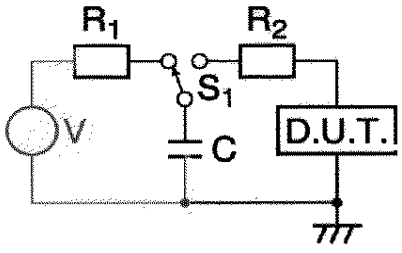
Test Item	Test Conditions	Test Hours/Cycles	Sample No
Room Temperature life test	25°C±3°C, DC 25mA	1000 hr	0/100
High Temperature humidity life test	60°C±3°C, 95%±2%RH, DC 20mA(15mA)	1000 hr	0/100
High Temperature life test	85°C±3°C, DC 10mA(7mA)	1000 hr	0/100
Temperature Cycle	-40°C ~ 25°C ~ 100°C ~ 25°C [30min, 5min, 30min, 5min], 70min/1cycle	100 cycles	0/100
Thermal Shock	-40°C ~ 100°C [30min, 30min], 60min/1cycle	100 cycles	0/100
Reflow (Pb-Free)	Peak 260±5°C for 10sec	3 times	0/50
Vibration test	100~2000~100Hz 200m/S ² , Sweep 4min, 48min X, Y, Z 3direction.	4 cycles	0/50
ESD(HBM)	 <p>-R1:10MΩ , R2:1.5KΩ , C:100pF</p>	1 time	0/50

2) Criteria for Judging the Damage

Item	Symbol	Test Condition	Limit	
			Min	Max
Forward Voltage	VF	IF=20mA	-	U.S.L.*1.2
Luminous intensity	IV	IF=20mA	L.S.L.*0.5	-

* USL : Upper Standard Level LSL : Lower Standard Level

8. Solder Conditions

1) Reflow Conditions (Pb Free)

Reflow Frequency : 2 times max.

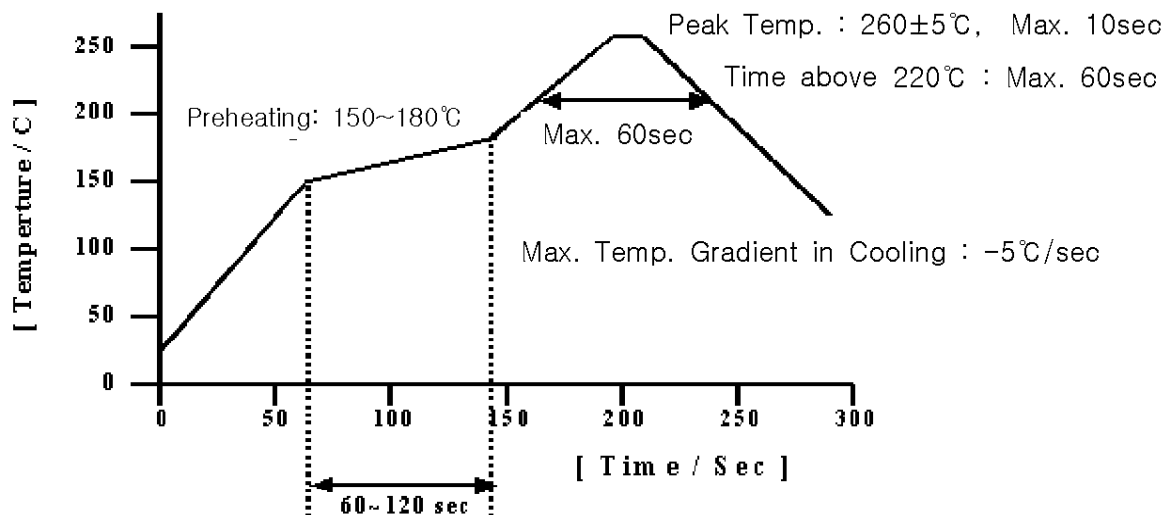

2) For Manual Soldering

Not more than 5 seconds @MAX300°C, under soldering iron.(one time only)

9. Taping Dimension

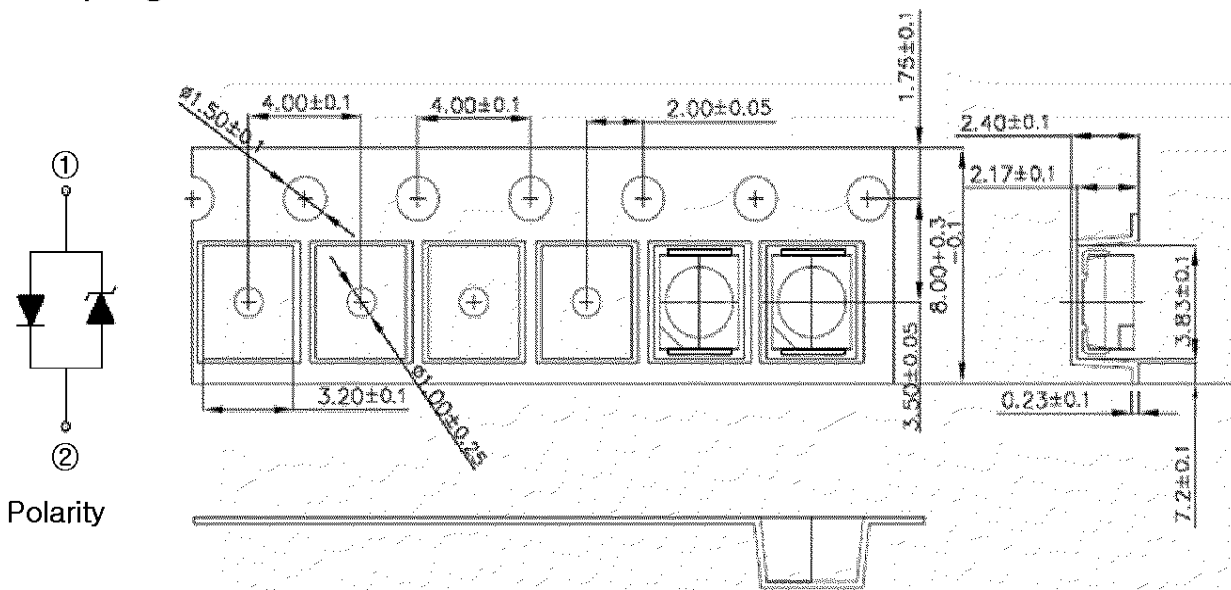

End				Start
More than 40 mm Unloaded tape	Mounted with Flash LED	More than (100~200)mm Unloaded tape	Leading part more than (200~400)mm	

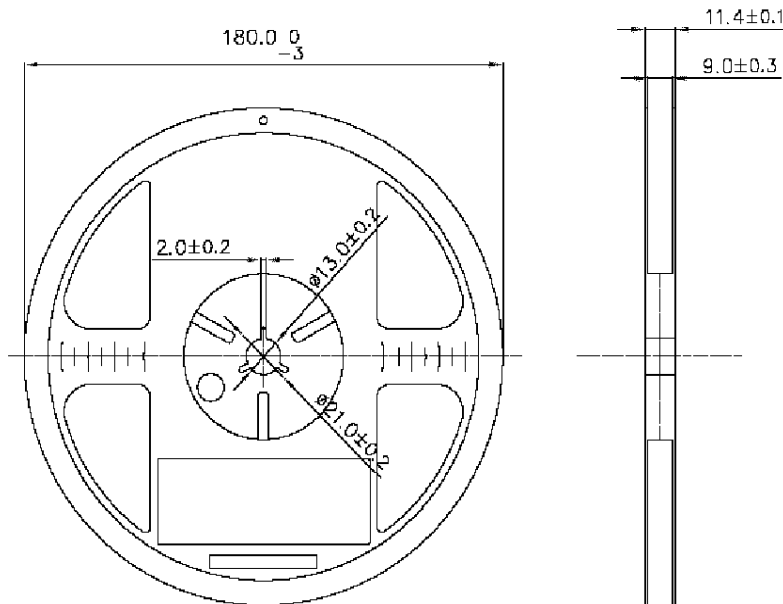

Tolerance ± 0.2 , Unit:mm

- (1) Quantity : The quantity/reel to be 2000pcs.
- (2) Cumulative Tolerance : Cumulative tolerance/10 pitches to be ± 0.2 mm
- (3) Adhesion Strength of Cover Tape : Adhesion strength to be 0.1–0.7N when the cover tape is turned off from the carrier tape at 10° angle to be the carrier tape.
- (4) Packaging : P/N, Manufacturing data code no. and quantity to be indicated on a damp proof package.

10. Label Structure

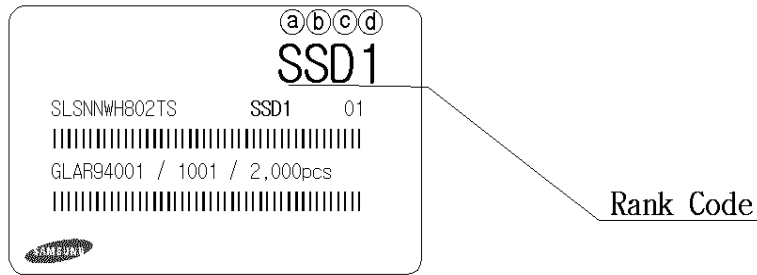

N.B) Denoted rank is the only example.

Rank Code

- Ⓐ : Forward Voltage(V_F) Rank (refer to page. 3)
- Ⓑ : Chromaticity Coordinate Rank (refer to page. 3)
- ⒸⒹ : Luminous Intensity(I_v) Rank (refer to page. 3)

11. Lot Number

The Lot number is composed of the following characters

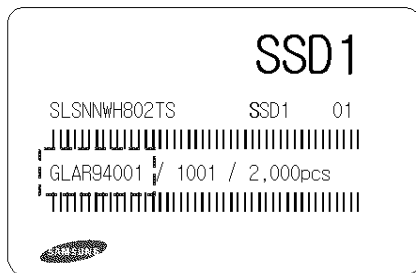

- ◎◇◆□■△△△ / ▲▲▲ / 2000PCS
- : Production Site (S:SEMCO, G:Gosin China)
- ◎ : L (LED)
- ◇ : Product State (A:Normality, B: Bulk, C:First Production, R:reproduction, S:Sample)
- ◆ : Year (Q:2006, R:2007, S:2008...)
- : Month (1 ~ 9, A, B)
- : Day (1 ~ 9, A, B ~ V)
- △ : SEMCO. Product number (1 ~ 999)
- ▲ : Reel Number (1 ~ 999)

12. Reel Packing Structure

Reel

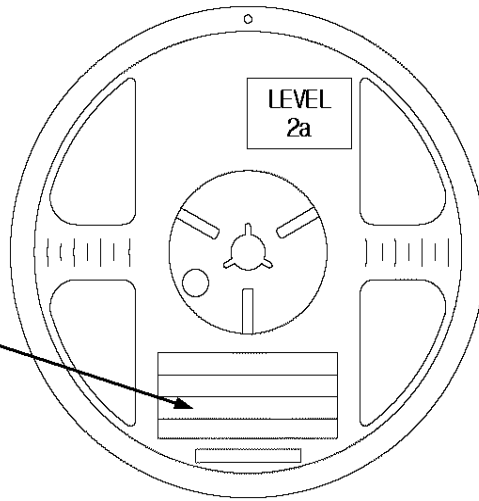
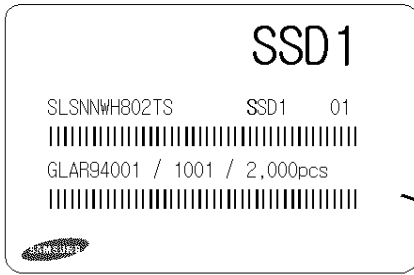

Aluminum Vinyl Bag

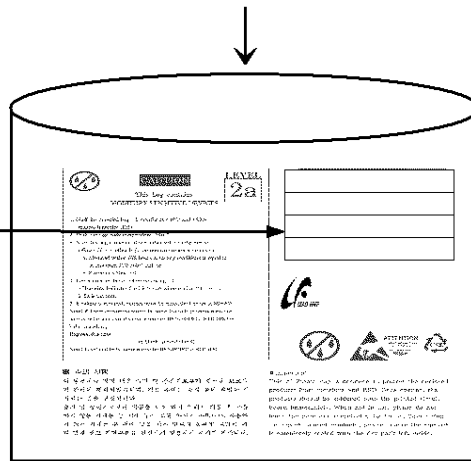
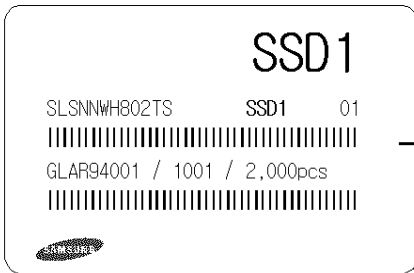

Material : Paper(SW3B(B))

TYPE	SIZE(mm)		
	a	b	c
7inch	245	220	182

① SIDE

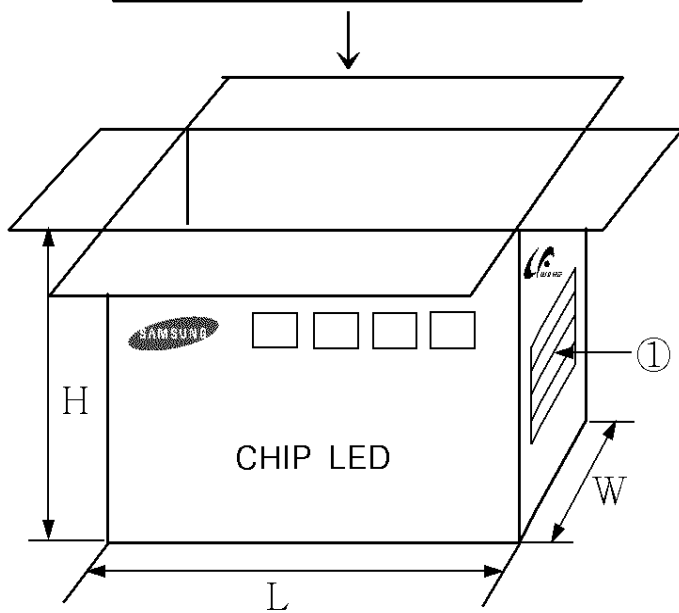
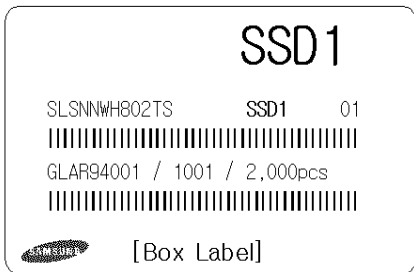

14. Precaution for Use

1) For over-current-proof function, customers are recommended to apply resistors to prevent sudden change of the current caused by slight shift of the voltage.
電圧の少しの変更により引き起こされる突然の電流変更を防ぐために過電流防止機能の抵抗器を適用する ように勧めします。

2) This device should not be used in any type of fluid such as water, oil, organic solvent, etc. When washing is required, IPA is recommended to use.
本製品は、水、油、有機的な溶剤などの任意のタイプの流体の中で使用しないで下さい。
洗浄が要求される場合、IPAを使用して下さい。

3) When the LEDs illuminate, operating current should be decided after considering the ambient maximum temperature.
LED発光の時、動作電流はLED周囲の温度条件により使用電流を決めてください。

4) LEDs must be stored in a clean environment.

If the LEDs are to be stored for 3 months or more after being shipped from SEMCO, they should be packed by a sealed container with nitrogen gas injected.
(Shelf life of sealed bags: 12 months, temp. 0~40°C, 20~70%RH)

本製品は清潔な大気を維持する環境で保存して下さい。

LEDが送られた後に3か月以上保存される場合、窒素雰囲気具备了密封したコンテナ装置に保管して下さい。(0~40°C以下、20~70%のRH以下とし12か月以内)

5) After storage bag is open, device subjected to soldering, solder reflow, or other high temperature processes must be:

a. Mounted within 168 hours (7 days) at an assembly line with a condition of no more than 30°C/60%RH,

b. Stored at <10% RH

開封後、Reflowハンダあるいは他の高温プロセスにさらされる場合は、

a. 工場条件30°C以下、60%RH以下の条件で168時間（7日）以内にマウントを完了して下さい。

b. また10%のRHで保存して下さい。

6) Repack unused Products with anti-moisture packing, fold to close any opening and then store in a dry place.

未使用のLEDが残った場合は、乾燥剤（シリカゲル）入り乾燥容器などで保管して下さい。
なお当社防湿袋に戻し、再封印することを推奨します。

7) Devices require baking before mounting, if humidity card reading is $>65\%$ at $23\pm 5^{\circ}\text{C}$.

以下の場合、マウントする前にbakeすることをお勧めします。

$23\pm 5^{\circ}\text{C}$ での湿度カードの表紙が65%以上の時

8) Devices must be baked for 24hours at $65\pm 5^{\circ}\text{C}$, if baking is required.

Bakingが要求される場合、 $65\pm 5^{\circ}\text{C}$ で24時間Bakeすることをお勧めします。

9) The LEDs are sensitive to the static electricity and surge. It is recommended to use a wrist band or anti-electrostatic glove when handling the LEDs.

If voltage exceeding the absolute maximum rating is applied to LEDs, it may cause damage or even destruction to LED devices.

Damaged LEDs may show some unusual characteristics such as increase in leak current, lowered turn-on voltage, or abnormal lighting of LEDs at low current.

本製品は静電気やサージ電圧に敏感で、素子の損傷や信頼性低下を起こすことがあります。本LEDの取り扱いに際しては、手首バンドまたは静電気防止グローブ等の静電気対策を十分行って下さい。

LEDに最大定格電圧値を超過される場合、LEDの損傷を引き起こし、破壊する可能性があります。

損傷したLEDには、漏洩電流が著しく大きくなり、順方向の立ち上がり電圧が低下したり低電流で発光しなくなる等の異常が現れます。

