

N-AFE SOFTWARE-CONFIGURABLE ANALOG FRONT END FAMILY WITH UNIVERSAL ANALOG INPUTS



Software-defined factory is enabled by NXP's N-AFE analog front end. Beyond Industry 4.0

Manufacturing today is facing a significant transformation called Industry 4.0. Market demands such as increased product variability is changing the way traditional production is set. In order to meet these demands, a way to reconfigure production lines to a new run in a timely manner is needed to maintain profit margins. The ability of smart factories to reconfigure is key.

NXP's N-AFE analog front end targeting factory automation applications can be configured for different types of inputs such as voltage, current, resistance, RTD and more to enable a software-defined factory. Also, improved product quality is expected, and this is possible thanks to enhanced accuracy and precision. In addition, predictive maintenance is making it possible to identify issues before they occur to avoid downtime. NXP's N-AFE advanced diagnostics and anomaly detection features enable predictive maintenance for a successful smart factory.



RECONFIGURABILITY

RECONFIGURE A SMART FACTORY AND ADJUST SETTINGS BASED ON SHIFTING MARKET NEEDS



ACCURACY AND PRECISION

IMPROVED PRODUCT QUALITY THANKS TO ENHANCED ACCURACY AND PRECISION



PREDICTIVE MAINTENANCE

DIAGNOSTICS AND ANOMALY DETECTION TO IDENTIFY ISSUES BEFORE THEY OCCUR

N-AFE BLOCK DIAGRAM

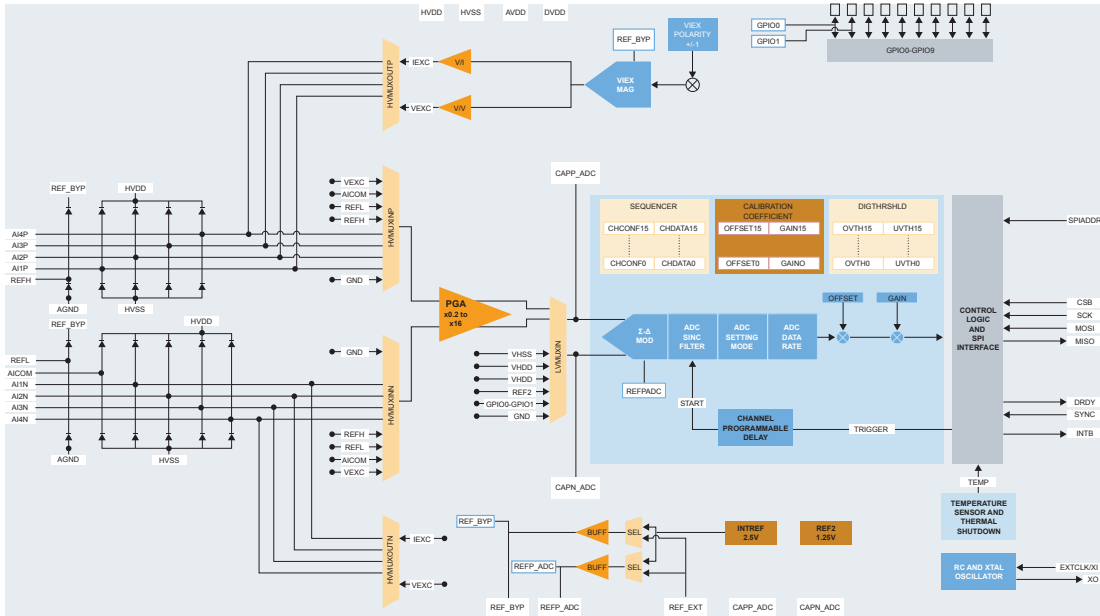

FAMILY PRODUCT FEATURES

- Up to 8 software-configurable channels
 - Voltage, current, RTD, thermocouple
 - +/-0.15 to +/-12.5 ranges for single-ended signals
 - ±40 V protection to miswiring
- High accuracy
 - 0.002% system accuracy at room
 - 0.05% system accuracy over temperature
 - 10 ppm max system level non-linearity
- High precision, 180 dB dynamic range
 - 17-bit ENOB at 7 us/reading for single input
 - 17-bit ENOB at 36 us/reading for multi-input
 - 1.0 uVrms at 2.25 ksp/s
 - 0.2 uVrms at 60 sp/s and 50 sp/s
- Fast and flexible data acquisition
 - 20 us/reading for multi-inputs
 - Fast and configurable sequencer to offload EP
 - Fast and flexible reading modes
- Digital factory calibration and self-calibration
 - 24-bit wide x 48-word deep NVM for calibration coefficients
 - Internal sources for system self-calibration

- Advanced protection and diagnostic
 - Supplies monitoring, UVLO, OVD on signal path
 - Redundant voltage reference and temp sensor
 - BIST for complete signal path monitoring and for failure and aging prediction

Part Number	Description
NAFE11388	Universal 8-input Low-Power +/- 25 V AFE
NAFE71388	Universal 8-input High-Speed +/- 25 V AFE
NAFE11388-EVB	Development Programming Board and Samples

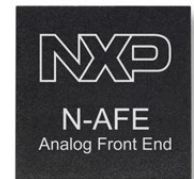

SYSTEM SOLUTION FACTORY AUTOMATION CONTROLLER

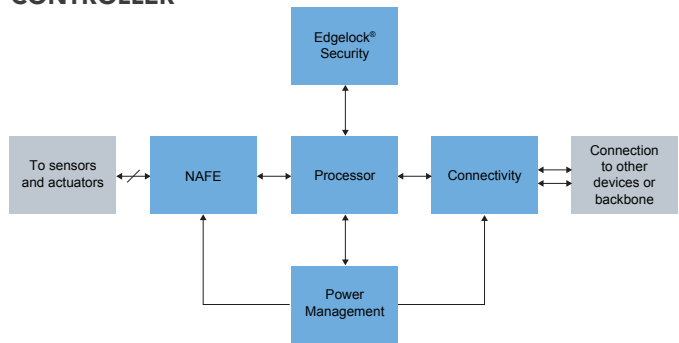

www.nxp.com/NAFE

NXP, the NXP logo, CodeWarrior, PowerQUICC, Processor Expert and StarCore are trademarks of NXP B.V. All other product or service names are the property of their respective owners. © 2022 NXP B.V.

Document Number: NAFEFAMFS REV 0