

TOSHIBA Intelligent Power Device High Voltage Monolithic Silicon Power IC

# TPD4125AK

The TPD4125AK is a DC brush less motor driver using high voltage PWM control. It is fabricated by high voltage SOI process. It is 3-shunt type. It contains level shift high-side driver, low-side driver, IGBT outputs, FRDs and protective functions for under voltage protection circuits and thermal shutdown circuit. It is easy to control a DC brush less motor by just putting logic inputs from a MPU or motor controller to the TPD4125AK.

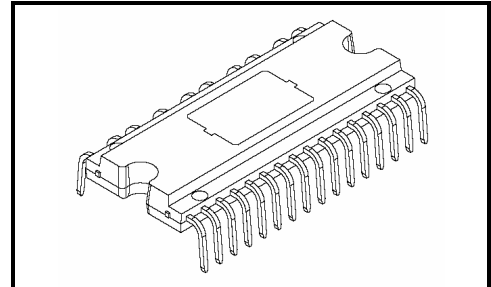

Weight  
HDIP26-P-1332-2.0 : 3.8 g (typ.)

## Features

- Bootstrap circuit gives simple high-side supply.
- Bootstrap diodes are built in.
- A dead time can be set as a minimum of 1.4  $\mu$ s, and it is the best for a Sine-wave from drive.
- 3-phase bridge output using IGBTs.
- FRDs are built in.
- Included under voltage protection and thermal shutdown.
- The regulator of 7V (typ.) is built in.
- Package: 26-pin DIP.

This product has a MOS structure and is sensitive to electrostatic discharge. When handling this product, ensure that the environment is protected against electrostatic discharge.

**Pin Assignment**

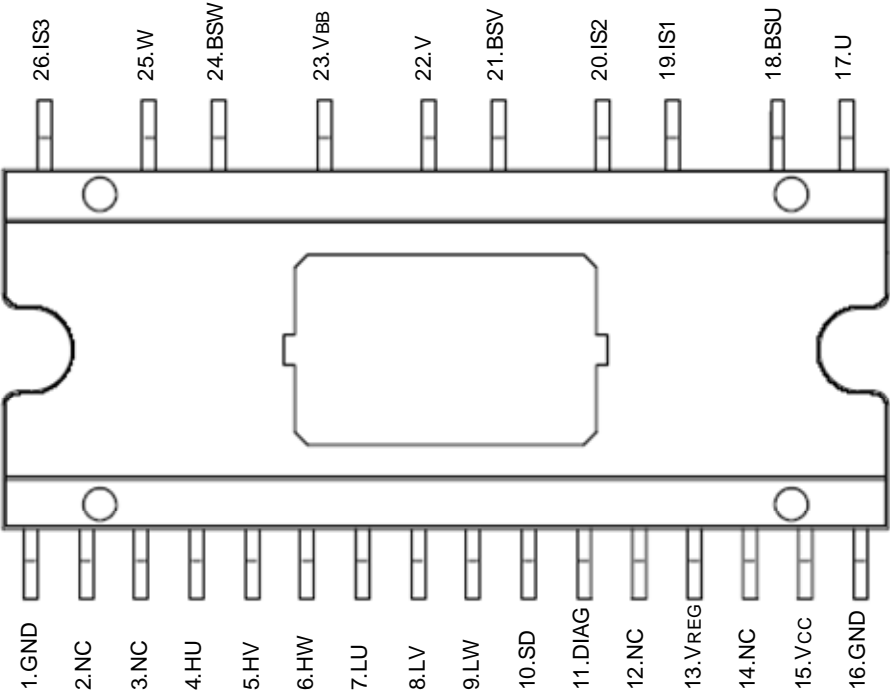

**Marking**

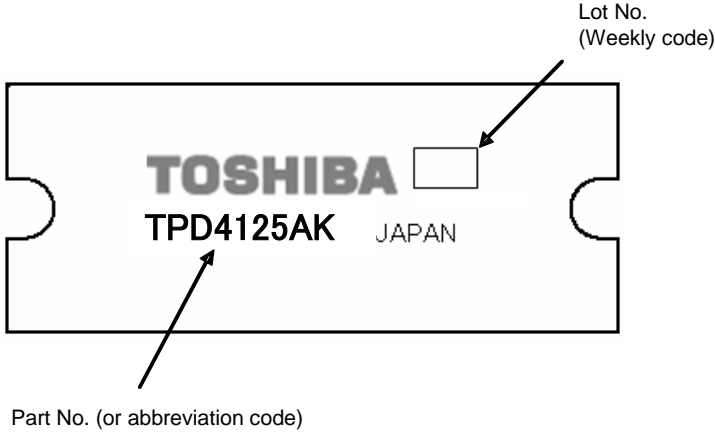

**Block Diagram**

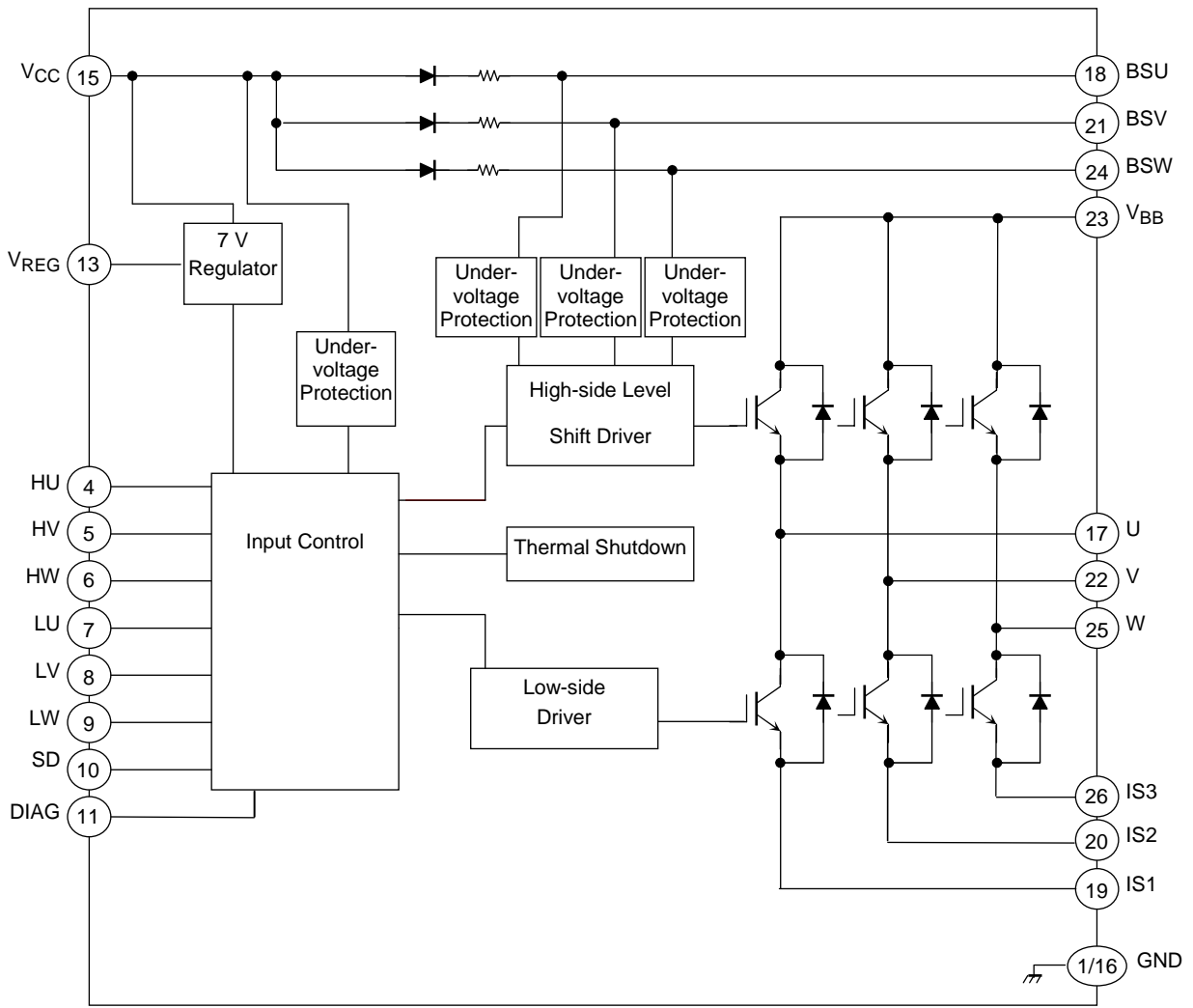

## Pin Description

Pin No.	Symbol	Pin Description
1	GND	Ground pin.
2	NC	Unused pin, which is not connected to the chip internally.
3	NC	Unused pin, which is not connected to the chip internally.
4	HU	The control terminal of IGBT by the high side of U. It turns off less than 1.5V. It turns on more than 3.5V.
5	HV	The control terminal of IGBT by the high side of V. It turns off less than 1.5V. It turns on more than 3.5V.
6	HW	The control terminal of IGBT by the high side of W. It turns off less than 1.5V. It turns on more than 3.5V.
7	LU	The control terminal of IGBT by the low side of U. It turns off less than 1.5V. It turns on more than 3.5V.
8	LV	The control terminal of IGBT by the low side of V. It turns off less than 1.5V. It turns on more than 3.5V.
9	LW	The control terminal of IGBT by the low side of W. It turns off less than 1.5V. It turns on more than 3.5V.
10	SD	Input pin of external protection. ("L" active, No input hysteresis)
11	DIAG	With the diagnostic output terminal of open drain , a pull-up is carried out by resistance. It turns it on at the time of unusual.
12	NC	Unused pin, which is not connected to the chip internally.
13	V <sub>REG</sub>	7V regulator output pin.
14	NC	Unused pin, which is not connected to the chip internally.
15	V <sub>CC</sub>	Control power supply pin.(15V typ.)
16	GND	Ground pin.
17	U	U-phase output pin.
18	BSU	U-phase bootstrap capacitor connecting pin.
19	IS1	U-phase IGBT emitter and FRD anode pin.
20	IS2	V-phase IGBT emitter and FRD anode pin.
21	BSV	V-phase bootstrap capacitor connecting pin.
22	V	V-phase output pin.
23	V <sub>BB</sub>	High-voltage power supply input pin.
24	BSW	W-phase bootstrap capacitor connecting pin.
25	W	W-phase output pin.
26	IS3	W-phase IGBT emitter and FRD anode pin.

**Equivalent Circuit of Input Pins**

**Internal circuit diagram of HU, HV, HW, LU, LV, LW input pins**

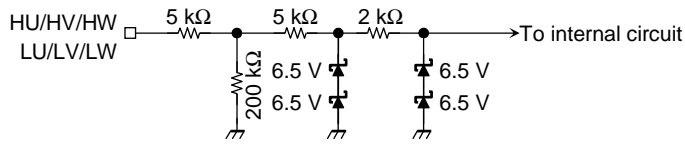

**Internal circuit diagram of SD pin**

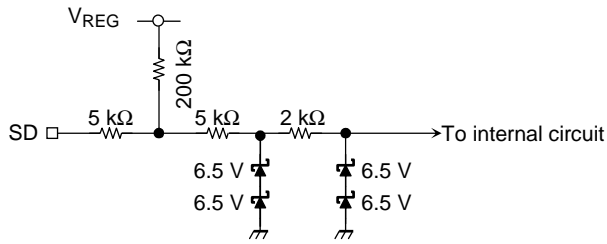

**Internal circuit diagram of DIAG pin**

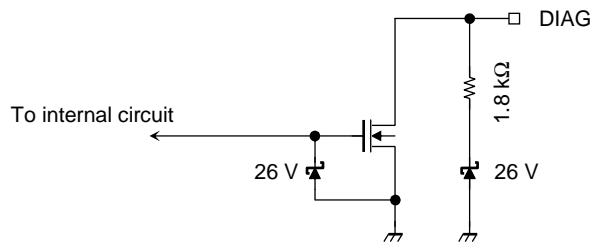

Timing Chart

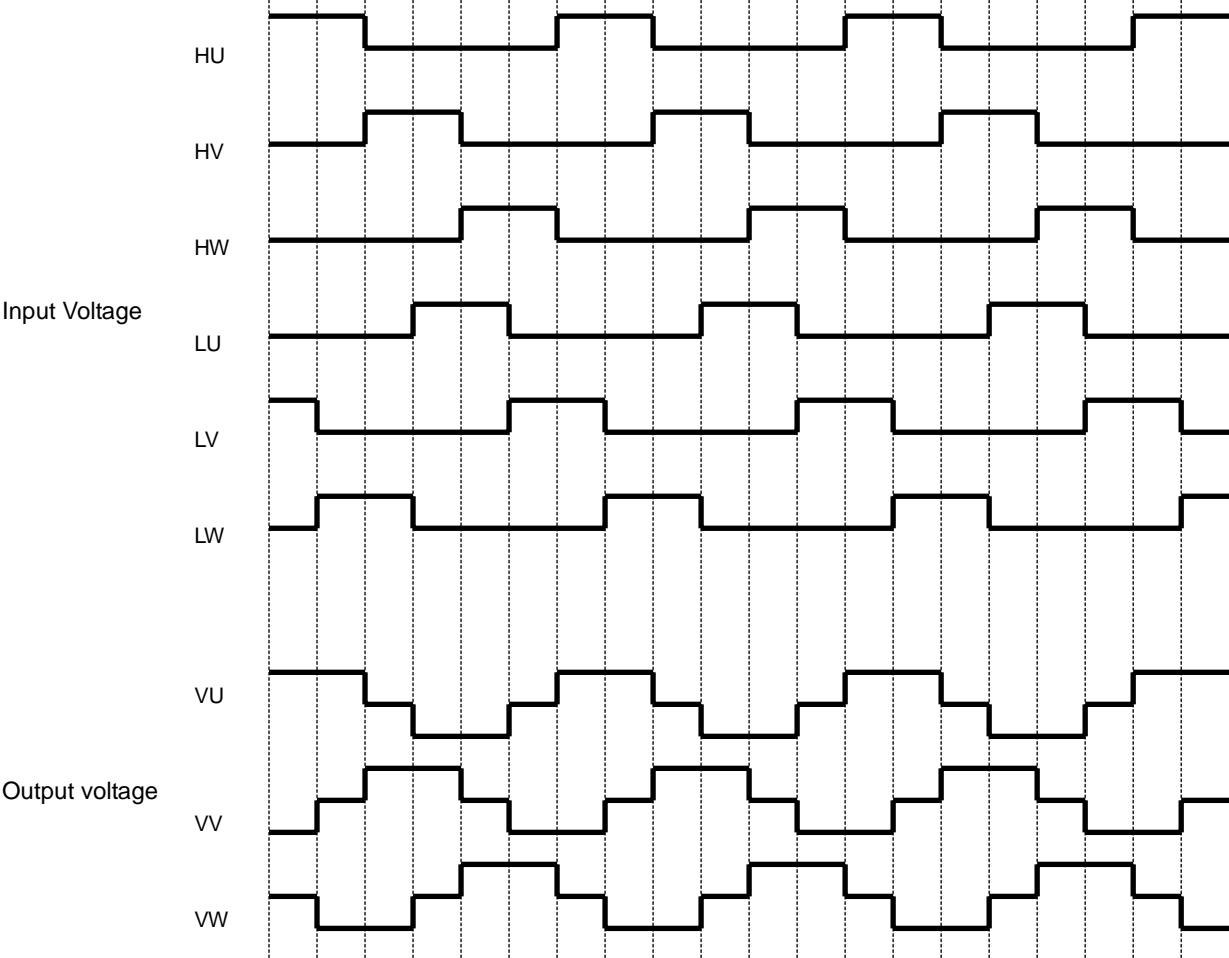

## Truth Table

Mode	Input							High side			Low side			DIAG
	HU	HV	HW	LU	LV	LW	SD	U phase	V phase	W phase	U phase	V phase	W phase	
Normal	H	L	L	L	H	L	H	ON	OFF	OFF	OFF	ON	OFF	OFF
	H	L	L	L	L	H	H	ON	OFF	OFF	OFF	OFF	ON	OFF
	L	H	L	L	L	H	H	OFF	ON	OFF	OFF	OFF	ON	OFF
	L	H	L	H	L	L	H	OFF	ON	OFF	ON	OFF	OFF	OFF
	L	L	H	H	L	L	H	OFF	OFF	ON	ON	OFF	OFF	OFF
	L	L	H	L	H	L	H	OFF	OFF	ON	OFF	ON	OFF	OFF
Thermal shutdown	H	L	L	L	H	L	H	OFF	OFF	OFF	OFF	OFF	OFF	ON
	H	L	L	L	L	H	H	OFF	OFF	OFF	OFF	OFF	OFF	ON
	L	H	L	L	L	H	H	OFF	OFF	OFF	OFF	OFF	OFF	ON
	L	H	L	H	L	L	H	OFF	OFF	OFF	OFF	OFF	OFF	ON
	L	L	H	H	L	L	H	OFF	OFF	OFF	OFF	OFF	OFF	ON
	L	L	H	L	H	L	H	OFF	OFF	OFF	OFF	OFF	OFF	ON
V <sub>CC</sub> Under-voltage	H	L	L	L	H	L	H	OFF	OFF	OFF	OFF	OFF	OFF	ON
	H	L	L	L	L	H	H	OFF	OFF	OFF	OFF	OFF	OFF	ON
	L	H	L	L	L	H	H	OFF	OFF	OFF	OFF	OFF	OFF	ON
	L	H	L	H	L	L	H	OFF	OFF	OFF	OFF	OFF	OFF	ON
	L	L	H	H	L	L	H	OFF	OFF	OFF	OFF	OFF	OFF	ON
	L	L	H	L	H	L	H	OFF	OFF	OFF	OFF	OFF	OFF	ON
V <sub>BS</sub> Under-voltage	H	L	L	L	H	L	H	OFF	OFF	OFF	OFF	ON	OFF	OFF
	H	L	L	L	L	H	H	OFF	OFF	OFF	OFF	OFF	ON	OFF
	L	H	L	L	L	H	H	OFF	OFF	OFF	OFF	OFF	ON	OFF
	L	H	L	H	L	L	H	OFF	OFF	OFF	ON	OFF	OFF	OFF
	L	L	H	H	L	L	H	OFF	OFF	OFF	ON	OFF	OFF	OFF
	L	L	H	L	H	L	H	OFF	OFF	OFF	OFF	ON	OFF	OFF
SD	*	*	*	*	*	*	L	OFF	OFF	OFF	OFF	OFF	OFF	ON

## Absolute Maximum Ratings (Ta = 25°C)

Characteristics	Symbol	Rating	Unit
Power supply voltage	V <sub>BB</sub>	500	V
	V <sub>CC</sub>	18	V
Output current (DC)	I <sub>out</sub>	3	A
Output current (pulse)	I <sub>out</sub>	4	A
Input voltage	V <sub>IN</sub>	-0.5~7	V
V <sub>REG</sub> current	I <sub>REG</sub>	50	mA
Power dissipation (IGBT 1 phase (T <sub>c</sub> = 25°C) )	P <sub>C</sub>	40	W
Power dissipation (FRD1 phase (T <sub>c</sub> = 25°C) )	P <sub>C</sub>	26	W
Operating temperature	T <sub>Jopr</sub>	-20~135	°C
Junction temperature	T <sub>J</sub>	150	°C
Storage temperature	T <sub>stg</sub>	-55~150	°C

Note: Using continuously under heavy loads (e.g. the application of high temperature/current/voltage and the significant change in temperature, etc.) may cause this product to decrease in the reliability significantly even if the operating conditions (i.e. operating temperature/current/voltage, etc.) are within the absolute maximum ratings and the operating ranges.

Please design the appropriate reliability upon reviewing the Toshiba Semiconductor Reliability Handbook ("Handling Precautions"/Derating Concept and Methods) and individual reliability data (i.e. reliability test report and estimated failure rate, etc).

## Thermal Characteristics

Characteristics	Symbol	Condition	Max	Unit
Thermal resistance, junction to case	R <sub>th(j-c)</sub> FRD	FRD 1 phase drive	4.8	°C/W
Thermal resistance, junction to case	R <sub>th(j-c)</sub> IGBT	IGBT 1 phase drive	3.1	°C/W



## Electrical Characteristics (Ta = 25°C)

Characteristics	Symbol	Test Condition	Min	Typ.	Max	Unit
Operating power supply voltage	$V_{BB}$	—	50	280	450	V
	$V_{CC}$	—	13.5	15	16.5	
Current dissipation	$I_{BB}$	$V_{BB} = 450\text{ V}$	—	—	0.5	mA
	$I_{CC}$	$V_{CC} = 15\text{ V}$	—	0.8	5	
	$I_{BS(ON)}$	$V_{BS} = 15\text{ V}$ , high side ON	—	220	410	$\mu\text{A}$
	$I_{BS(OFF)}$	$V_{BS} = 15\text{ V}$ , high side OFF	—	200	370	
Input voltage	$V_{IH}$	$V_{IN} = \text{"H"}$ , $V_{CC} = 15\text{ V}$	3.5	—	—	V
	$V_{IL}$	$V_{IN} = \text{"L"}$ , $V_{CC} = 15\text{ V}$	—	—	1.5	
SD input voltage	$V_{SD}$	$V_{CC} = 15\text{ V}$	—	2.5	—	V
Input current	$I_{IH}$	$V_{IN} = 5\text{ V}$	—	—	150	$\mu\text{A}$
	$I_{IL}$	$V_{IN} = 0\text{ V}$	—	—	100	
SD Input current	$I_{SDH}$	$V_{IN} = 5\text{ V}$	—	—	100	$\mu\text{A}$
	$I_{SDL}$	$V_{IN} = 0\text{ V}$	—	—	150	
Output saturation voltage	$V_{CEsatH}$	$V_{CC} = 15\text{ V}$ , $I_C = 1.5\text{ A}$ , high side	—	2.4	3	V
	$V_{CEsatL}$	$V_{CC} = 15\text{ V}$ , $I_C = 1.5\text{ A}$ , low side	—	2.4	3	
FRD forward voltage	$V_{FH}$	$I_F = 1.5\text{ A}$ , high side	—	1.6	2.0	V
	$V_{FL}$	$I_F = 1.5\text{ A}$ , low side	—	1.6	2.0	
BSD forward voltage	$V_F(\text{BSD})$	$I_F = 500\ \mu\text{A}$	—	0.9	1.2	V
Regulator voltage	$V_{REG}$	$V_{CC} = 15\text{ V}$ , $I_O = 30\text{ mA}$	6.5	7	7.5	V
Thermal shutdown temperature	TSD	$V_{CC} = 15\text{ V}$	135	—	185	$^{\circ}\text{C}$
Thermal shutdown hysteresis	$\Delta\text{TSD}$	$V_{CC} = 15\text{ V}$	—	50	—	$^{\circ}\text{C}$
$V_{CC}$ under voltage protection	$V_{CCUVD}$	—	10	11	12	V
$V_{CC}$ under voltage protection recovery	$V_{CCUVR}$	—	10.5	11.5	12.5	V
$V_{BS}$ under voltage protection	$V_{BSUVD}$	—	8	9	9.5	V
$V_{BS}$ under voltage protection recovery	$V_{BSUVR}$	—	8.5	9.5	10.5	V
DIAG saturation voltage	$V_{DIAGsat}$	$I_{DIAG} = 5\text{ mA}$	—	—	0.5	V
Output on delay time	$t_{on}$	$V_{BB} = 280\text{ V}$ , $V_{CC} = 15\text{ V}$ , $I_C = 1.5\text{ A}$	—	1.3	3	$\mu\text{s}$
Output off delay time	$t_{off}$	$V_{BB} = 280\text{ V}$ , $V_{CC} = 15\text{ V}$ , $I_C = 1.5\text{ A}$	—	1.0	3	$\mu\text{s}$
Dead time	$t_{dead}$	$V_{BB} = 280\text{ V}$ , $V_{CC} = 15\text{ V}$ , $I_C = 1.5\text{ A}$	1.4	—	—	$\mu\text{s}$
FRD reverse recovery time	$t_{rr}$	$V_{BB} = 280\text{ V}$ , $V_{CC} = 15\text{ V}$ , $I_C = 1.5\text{ A}$	—	200	—	ns

Application Circuit Example

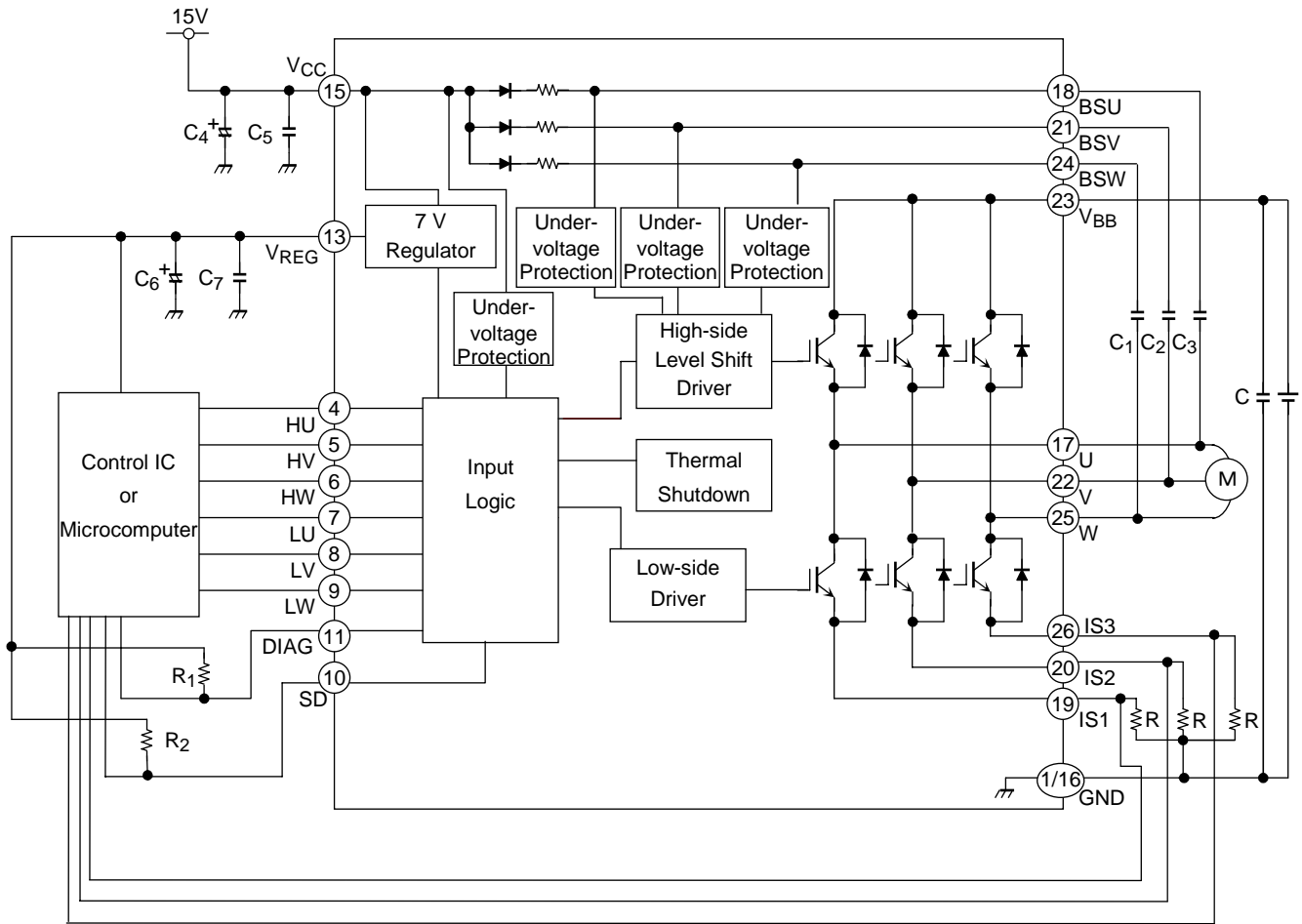

## External Parts

Typical external parts are shown in the following table.

Part	Typical	Purpose	Remarks
C <sub>1</sub> , C <sub>2</sub> , C <sub>3</sub>	25 V/2.2 $\mu$ F	Bootstrap capacitor	(Note 1)
C <sub>4</sub>	25 V/10 $\mu$ F	V <sub>CC</sub> power supply stability	(Note 2)
C <sub>5</sub>	25 V/0.1 $\mu$ F	V <sub>CC</sub> for surge absorber	(Note 2)
C <sub>6</sub>	25 V/1 $\mu$ F	V <sub>REG</sub> power supply stability	(Note 2)
C <sub>7</sub>	25 V/1000 pF	V <sub>REG</sub> for surge absorber	(Note 2)
R <sub>1</sub>	5.1 k $\Omega$	DIAG pin pull-up resistor	(Note 3)
R <sub>2</sub>	10 k $\Omega$	SD pin pull-up resistor	

Note 1: The required bootstrap capacitance value varies according to the motor drive conditions. The capacitor is biased by V<sub>CC</sub> and must be sufficiently derated for it.

Note 2: When using this product, adjustment is required in accordance with the use environment. When mounting, place as close to the base of this product leads as possible to improve the ripple and noise elimination.

Note 3: The DIAG pin is open drain. If not using the DIAG pin, connect to the GND.

## Handling precautions

- (1) Please control the input signal in the state to which the V<sub>CC</sub> voltage is steady. Both of the order of the V<sub>BB</sub> power supply and the V<sub>CC</sub> power supply are not cared about either.  
Note that if the power supply is switched off as described above, this product may be destroyed if the current regeneration route to the V<sub>BB</sub> power supply is blocked when the V<sub>BB</sub> line is disconnected by a relay or similar while the motor is still running.
- (2) The excess voltage such as the voltage surge which exceed the maximum rating is added, for example, may destroy the circuit. Accordingly, be careful of handling this product or of surge voltage in its application environment.

**Description of Protection Function**

(1) Under voltage protection

This product incorporates under voltage protection circuits to prevent the IGBT from operating in unsaturated mode when the VCC voltage or the VBS voltage drops.

When the VCC power supply falls to this product internal setting VCCUVD (=11 V typ.), all IGBT outputs shut down regardless of the input. This protection function has hysteresis. When the VCC power supply reaches 0.5 V higher than the shutdown voltage (VCCUVR (=11.5 V typ.)), this product is automatically restored and the IGBT is turned on again by the input.

When the VBS supply voltage drops VBSUVD (=9 V typ.), the high-side IGBT output shuts down.

When the VBS supply voltage reaches 0.5 V higher than the shutdown voltage (VBSUVR (=9.5 V typ.)), the IGBT is turned on again by the input signal.

(2) Thermal shutdown

This product incorporates a thermal shutdown circuit to protect itself against the abnormal state when its temperature rises excessively.

When the temperature of this chip rises to the internal setting TSD due to external causes or internal heat generation, all IGBT outputs shut down regardless of the input. This protection function has hysteresis  $\Delta TSD$  (=50 °C typ.). When the chip temperature falls to  $TSD - \Delta TSD$ , the chip is automatically restored and the IGBT is turned on again by the input.

Because the chip contains just one temperature detection location, when the chip heats up due to the IGBT, for example, the differences in distance from the detection location in the IGBT (the source of the heat) cause differences in the time taken for shutdown to occur. Therefore, the temperature of the chip may rise higher than the thermal shutdown temperature when the circuit started to operate.

(3) SD pin

SD pin is the input signal pin to shut down the internal output IGBT. Output of all IGBT is shutted down after delay times (2  $\mu$ s typ.) when "L" signal is inputted to the SD pin from external circuit(MCU etc.). It is possible to shut down IC when overcurrent and others is detected by external circuit. Shut down state is released by all of IC input signal "L". At open state of SD pin, shut down function can not operate.

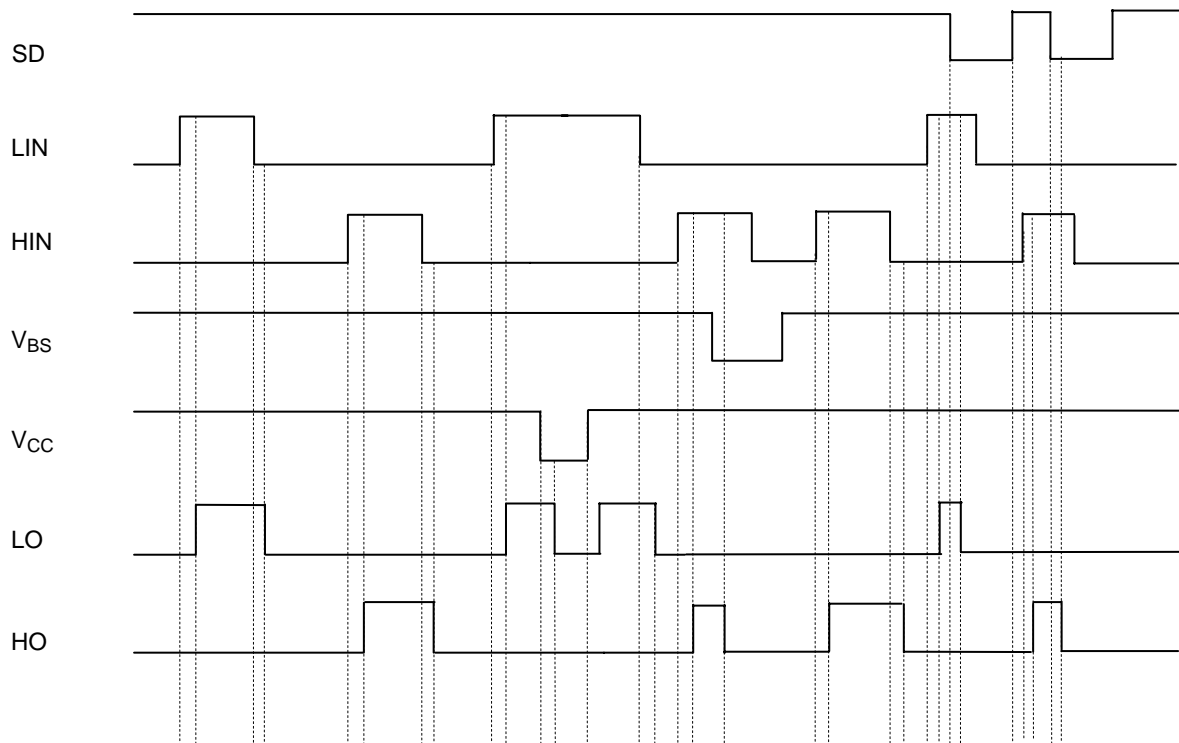

**Safe Operating Area**

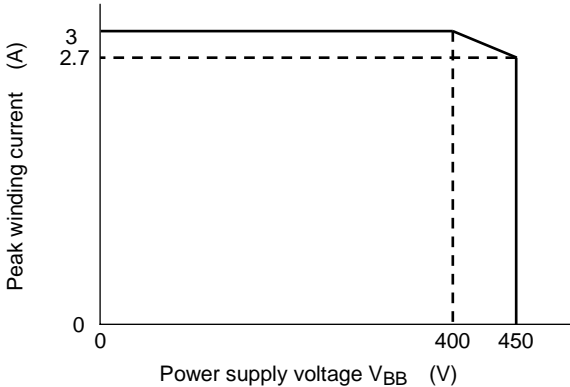
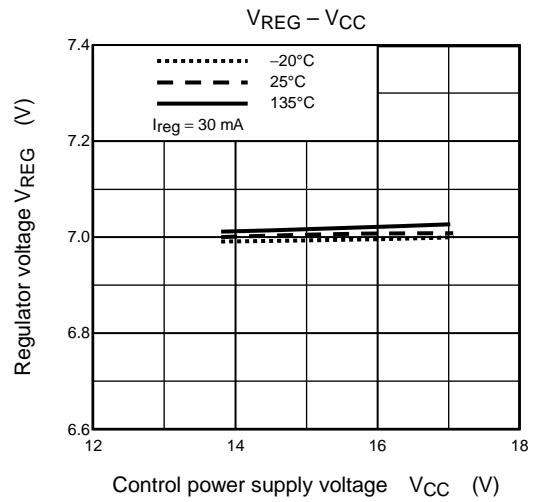
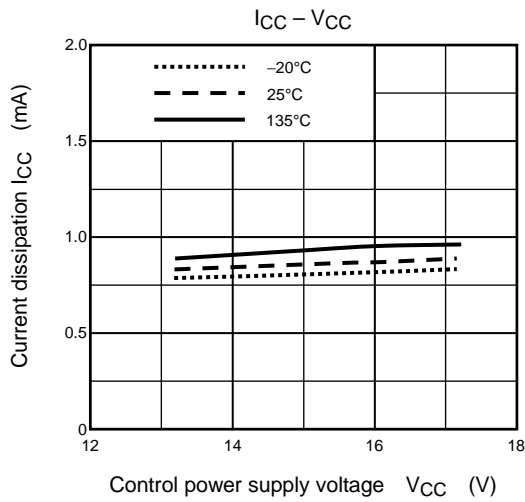
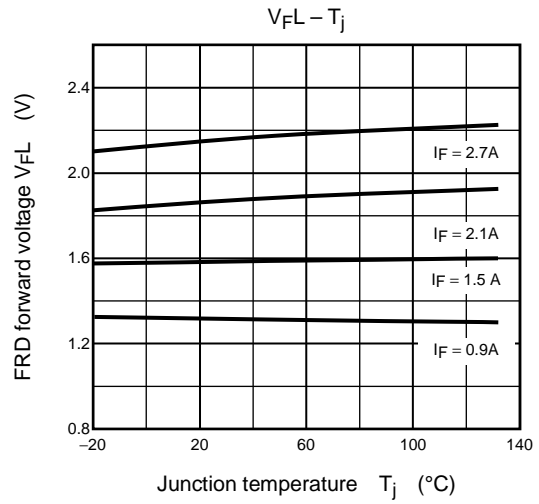
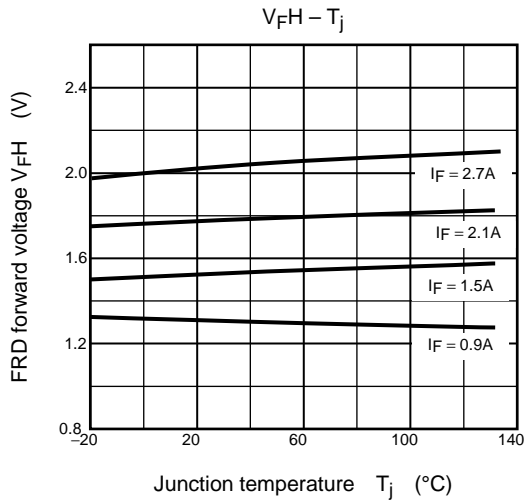
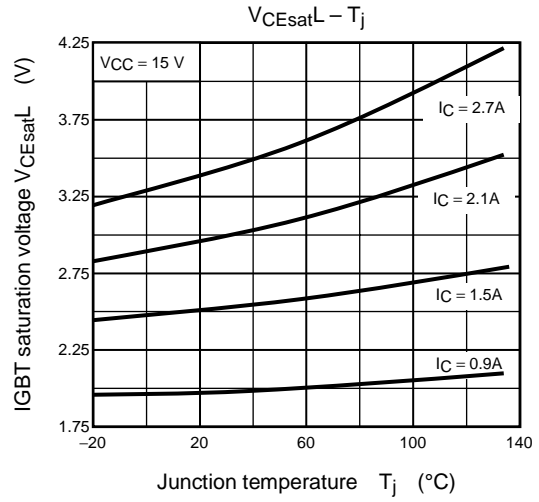
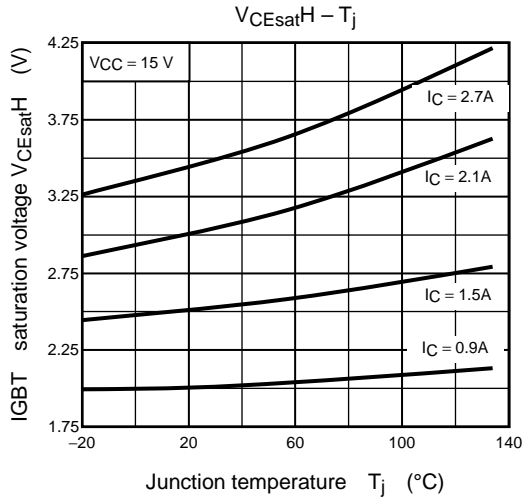
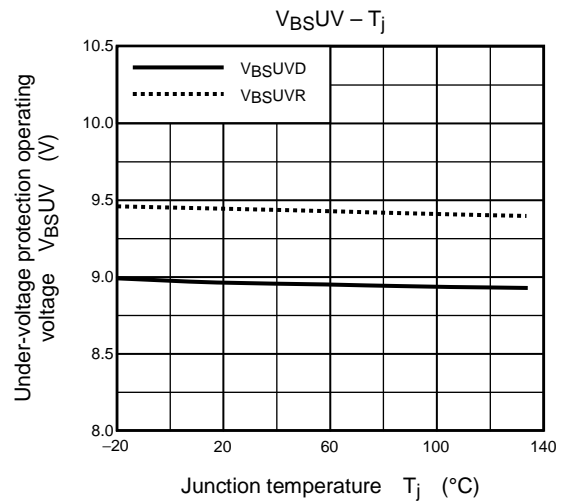
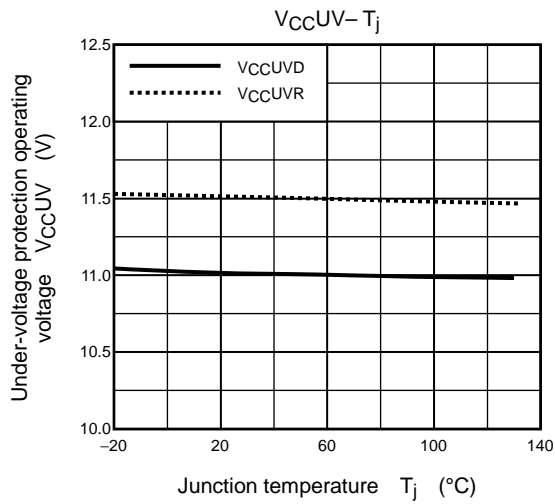
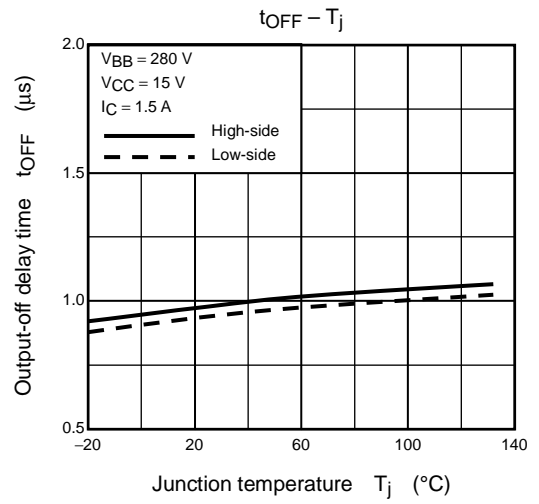
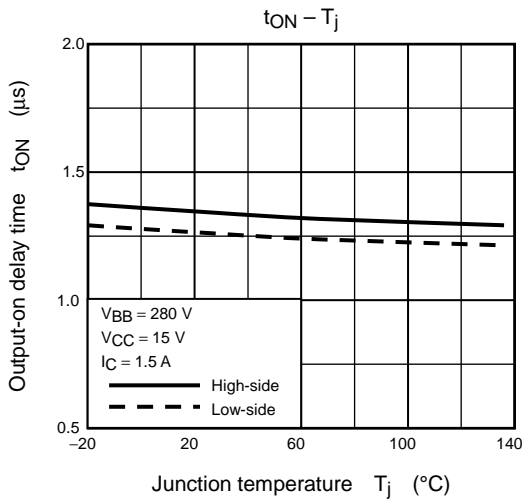
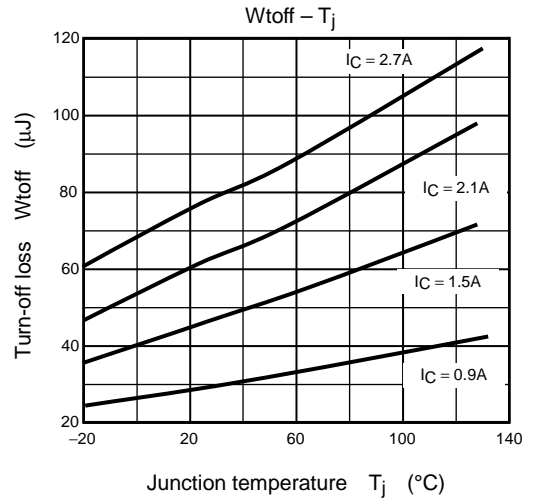
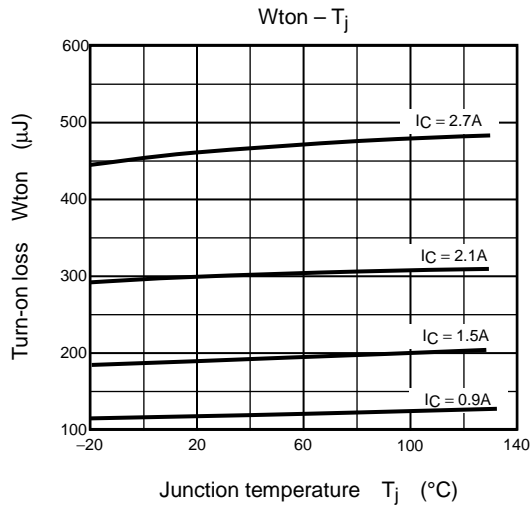
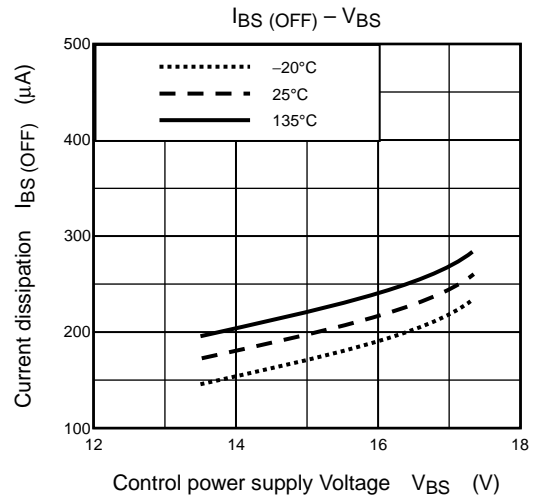
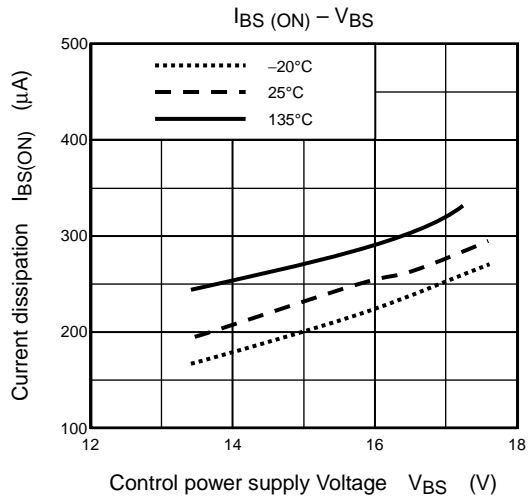

Figure 1 SOA at  $T_j = 135\text{ }^\circ\text{C}$

Note 1: The above safe operating areas are  $T_j = 135\text{ }^\circ\text{C}$  (Figure 1).









## Test Circuits

### IGBT Saturation Voltage (U-phase low side)

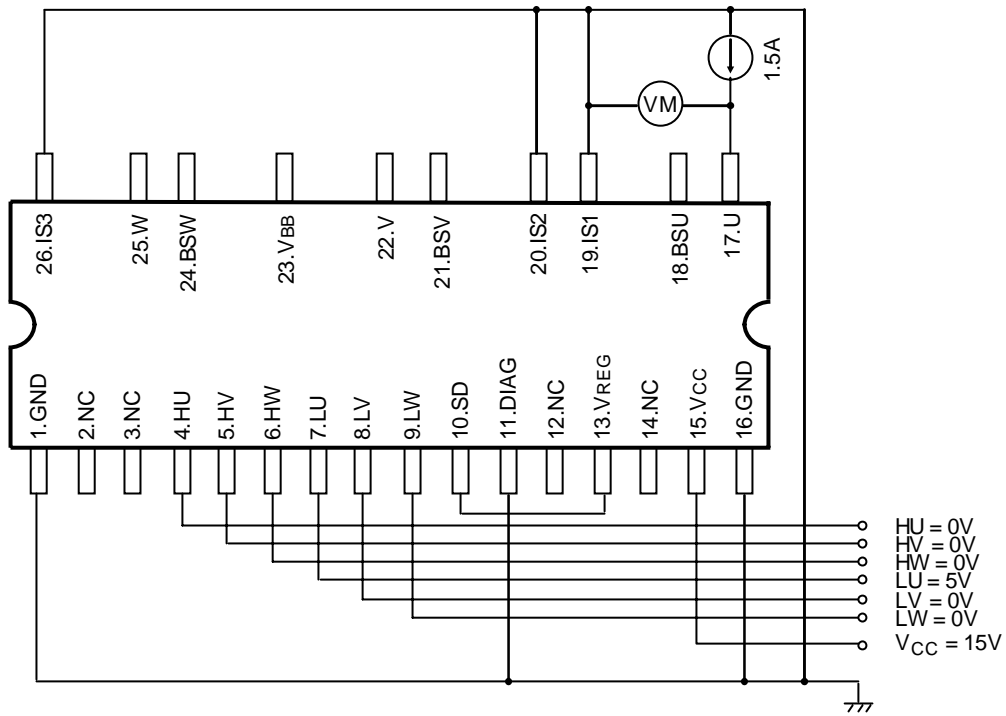

### FRD Forward Voltage (U-phase low side)

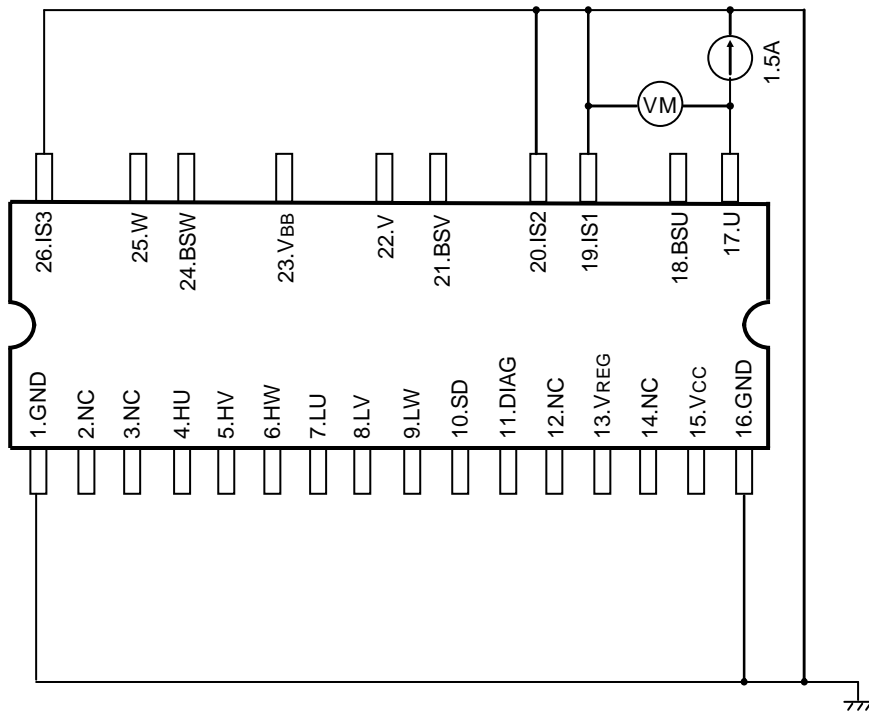

**V<sub>CC</sub> Current Dissipation**

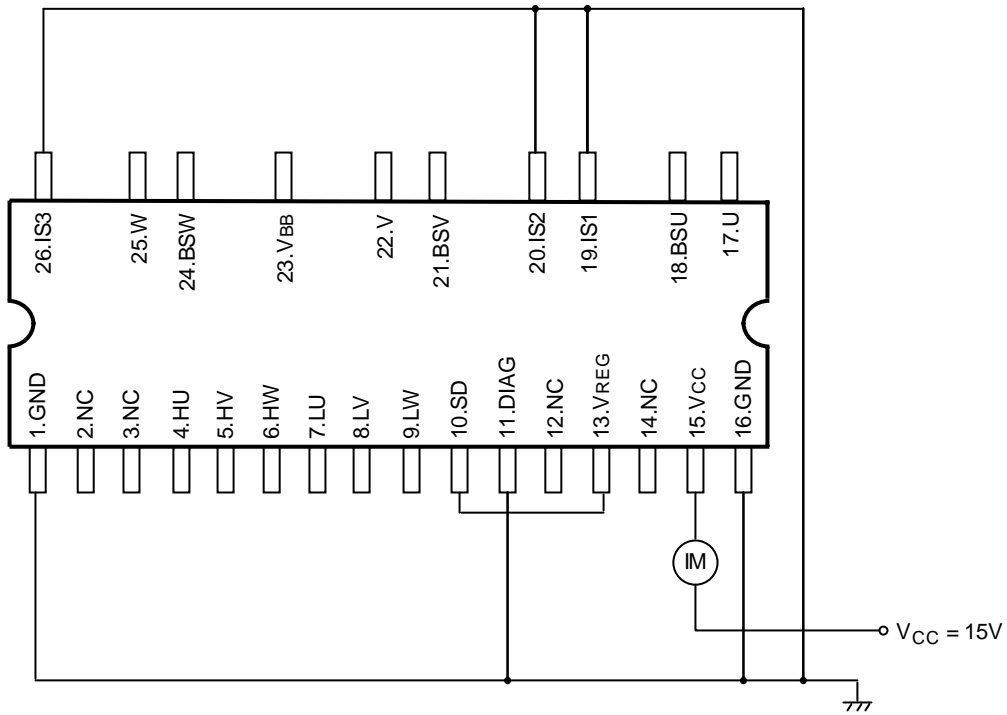

**Regulator Voltage**

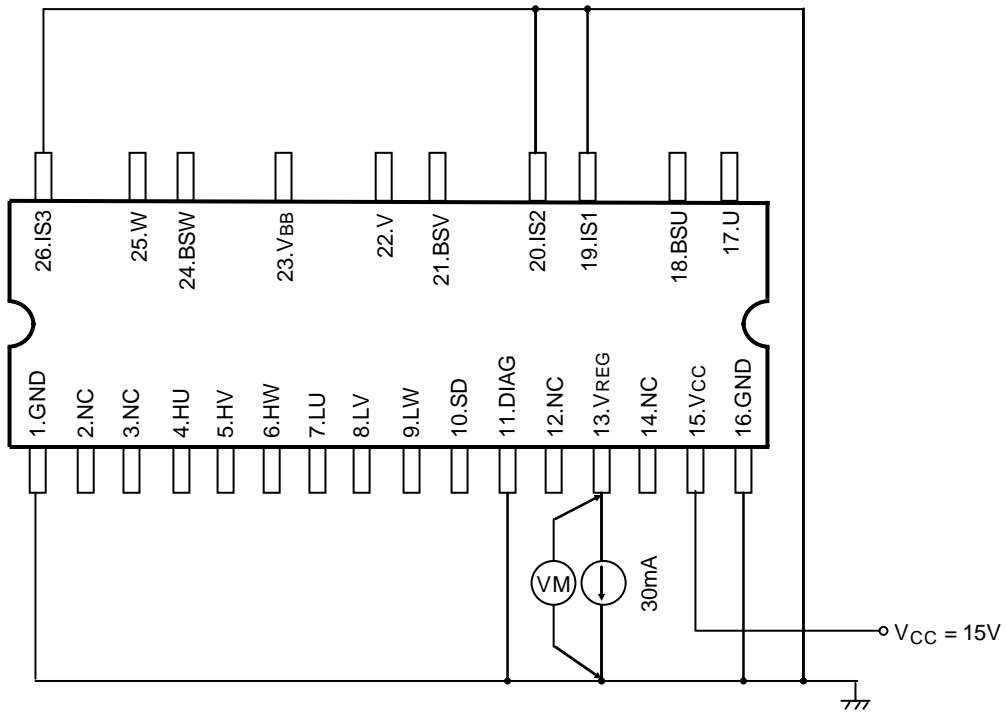

**Output ON/OFF Delay Time (U-phase low side)**

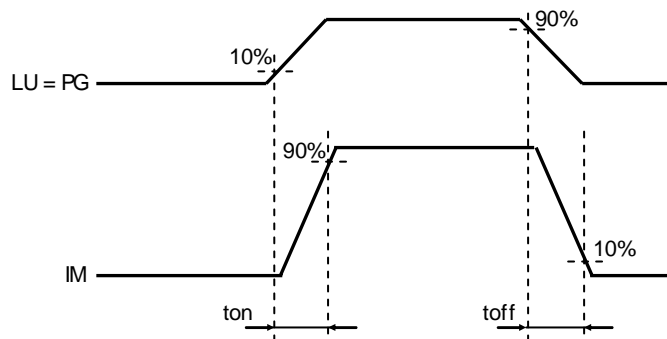
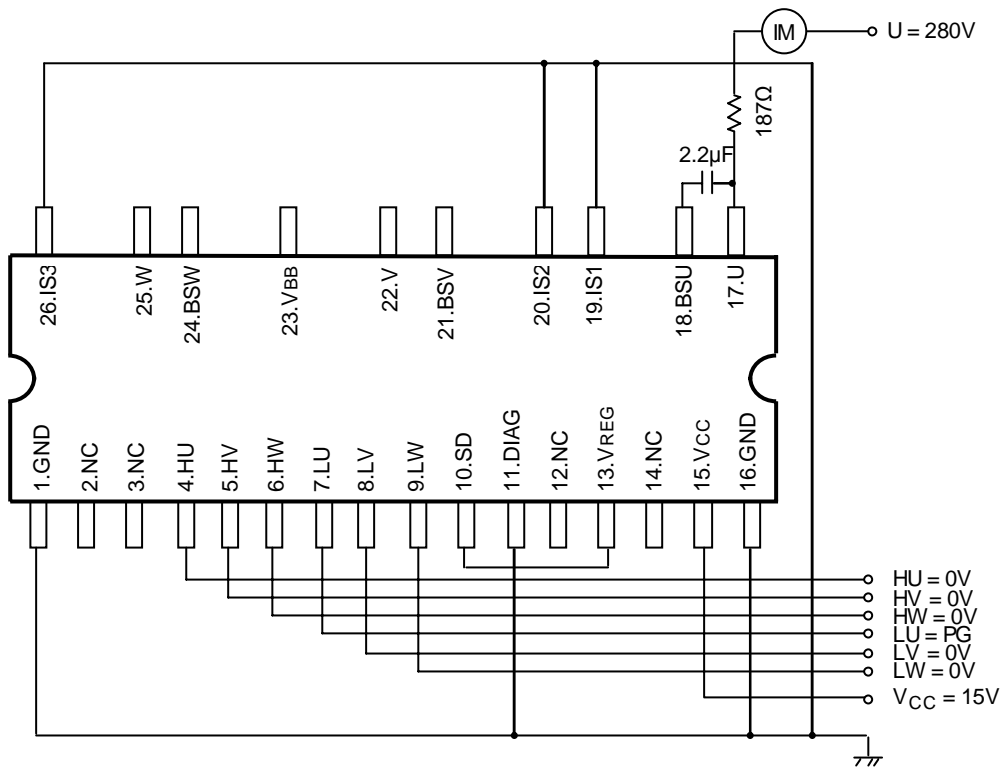

**V<sub>CC</sub> Under-voltage Protection Operating/Recovery Voltage (U-phase low side)**

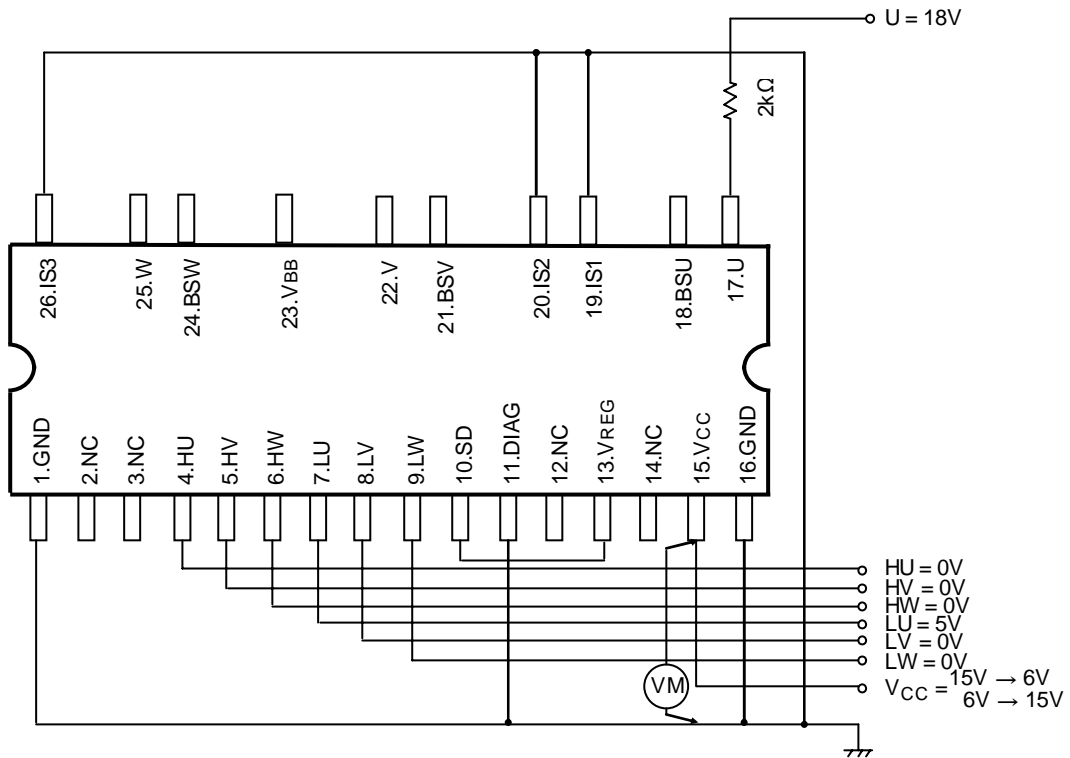

\*:Note: Sweeps the V<sub>CC</sub> pin voltage from 15 V and monitors the U pin voltage.  
 The V<sub>CC</sub> pin voltage when output is off defines the under voltage protection operating voltage.  
 Also sweeps from 6 V to increase. The V<sub>CC</sub> pin voltage when output is on defines the under voltage protection recovery voltage.

**V<sub>BS</sub> Under voltage Protection Operating/Recovery Voltage (U-phase high side)**

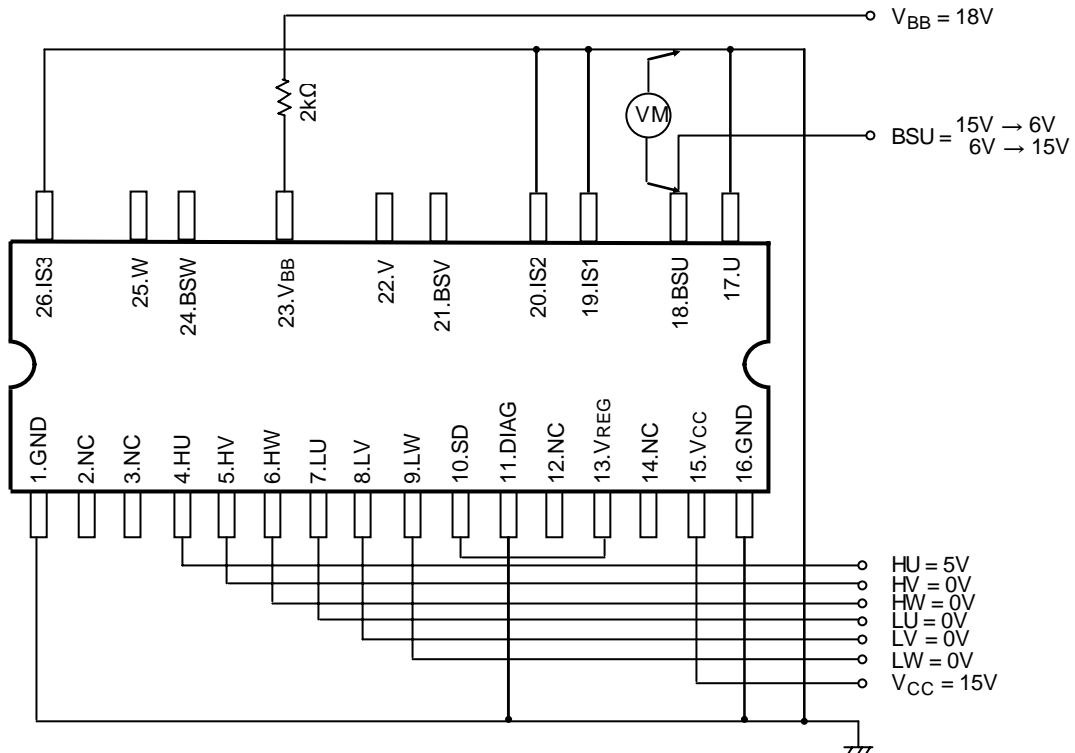

\*:Note:Sweeps the BSU pin voltage from 15 V to decrease and monitors the V<sub>BB</sub> pin voltage.The BSU pin voltage when output is off defines the under voltage protection operating voltage.Also sweeps the BSU pin voltage from 6 V to increase and change the HU pin voltage at 5 V→0 V→5 V each time. It repeats similarly output is on. When the BSU pin voltage when output is on defines the under voltage protection recovery voltage.

**V<sub>BS</sub> Current Dissipation (U-phase high side)**

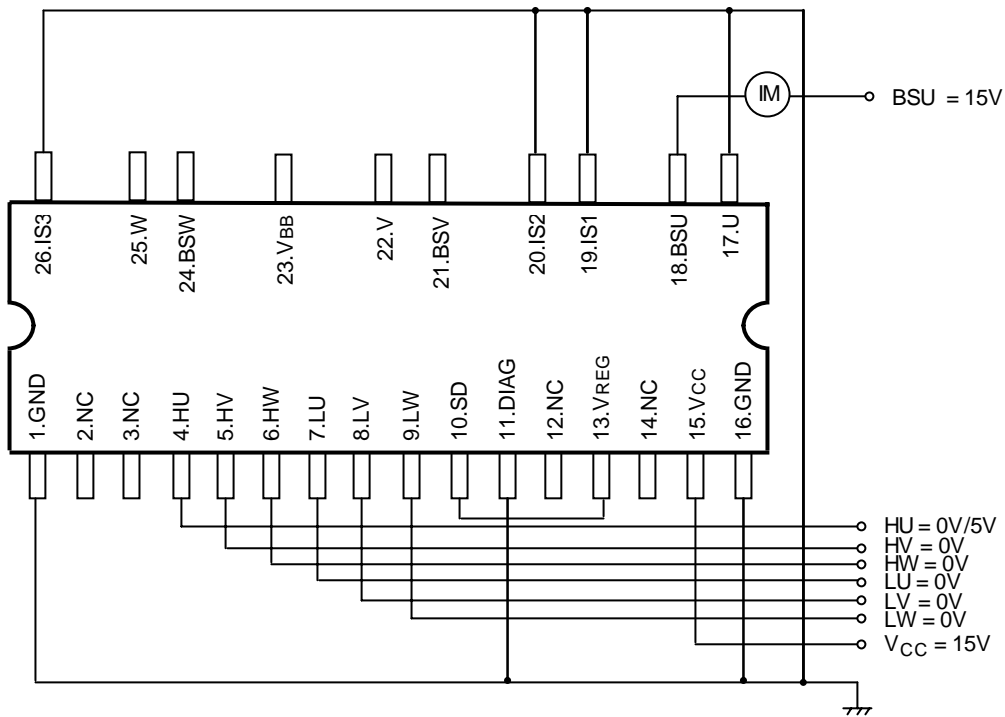

**Turn-On/Off Loss (low side IGBT + high side FRD)**

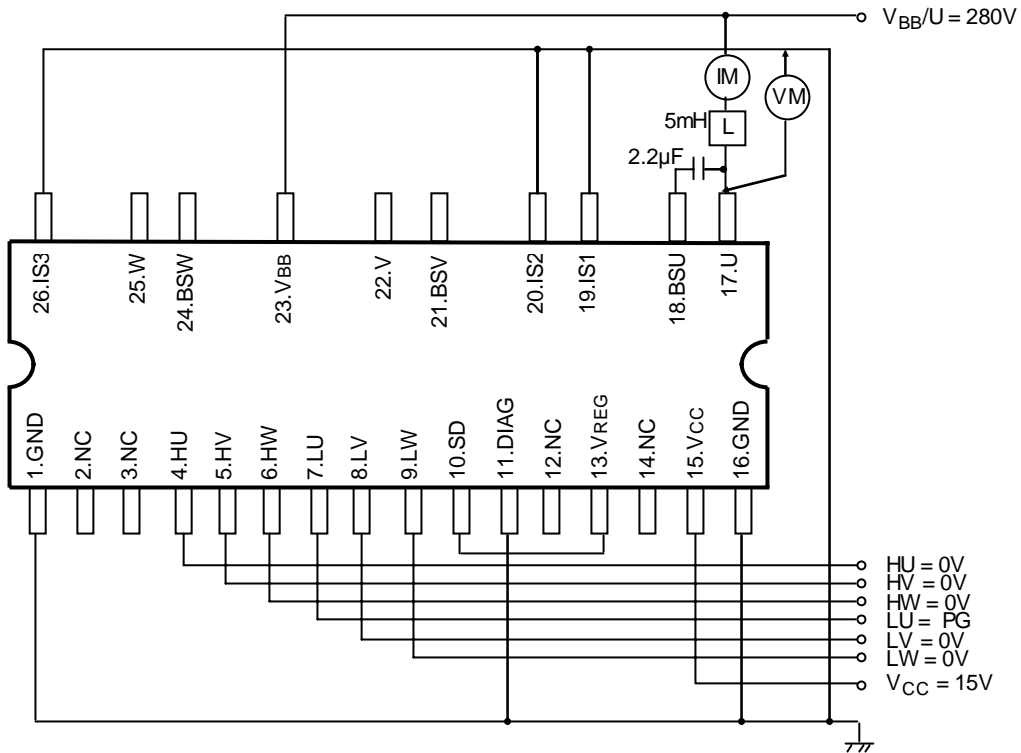

- HU = 0V
- HV = 0V
- HW = 0V
- LU = PG
- LV = 0V
- LW = 0V
- VCC = 15V

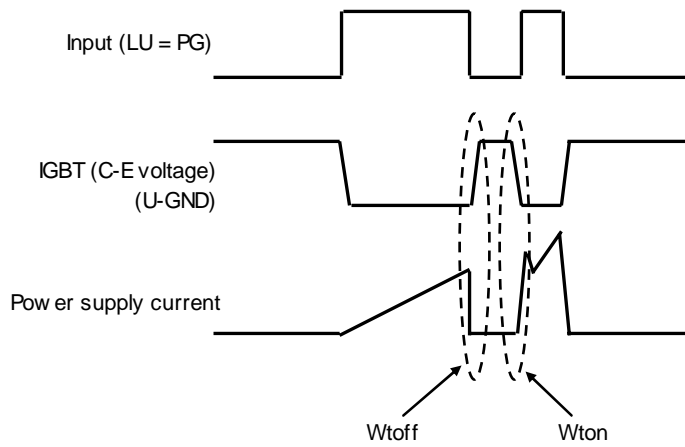



**RESTRICTIONS ON PRODUCT USE**

060629TBA

- The information contained herein is subject to change without notice.
- The information contained herein is presented only as a guide for the applications of our products. No responsibility is assumed by TOSHIBA for any infringements of patents or other rights of the third parties which may result from its use. No license is granted by implication or otherwise under any patent or patent rights of TOSHIBA or others.
- TOSHIBA is continually working to improve the quality and reliability of its products. Nevertheless, semiconductor devices in general can malfunction or fail due to their inherent electrical sensitivity and vulnerability to physical stress. It is the responsibility of the buyer, when utilizing TOSHIBA products, to comply with the standards of safety in making a safe design for the entire system, and to avoid situations in which a malfunction or failure of such TOSHIBA products could cause loss of human life, bodily injury or damage to property.  
In developing your designs, please ensure that TOSHIBA products are used within specified operating ranges as set forth in the most recent TOSHIBA products specifications. Also, please keep in mind the precautions and conditions set forth in the "Handling Guide for Semiconductor Devices," or "TOSHIBA Semiconductor Reliability Handbook" etc..
- The TOSHIBA products listed in this document are intended for usage in general electronics applications (computer, personal equipment, office equipment, measuring equipment, industrial robotics, domestic appliances, etc.). These TOSHIBA products are neither intended nor warranted for usage in equipment that requires extraordinarily high quality and/or reliability or a malfunction or failure of which may cause loss of human life or bodily injury ("Unintended Usage"). Unintended Usage include atomic energy control instruments, airplane or spaceship instruments, transportation instruments, traffic signal instruments, combustion control instruments, medical instruments, all types of safety devices, etc.. Unintended Usage of TOSHIBA products listed in this document shall be made at the customer's own risk.
- The products described in this document are subject to the foreign exchange and foreign trade laws.
- TOSHIBA products should not be embedded to the downstream products which are prohibited to be produced and sold, under any law and regulations.