

OSLON® 80 1 Micro Whites

ILM-ON01-####-SC221-WIR200. Series

Product Overview

The Micro OSLON® is now the smallest LED Light Engine from Intelligent LED Solutions measuring at just 11mm in diameter. Due to its unique design of the Micro OSLON® a secondary optic can be used with this LED Light Engine to narrow or widen the LED beam angle. Micro OSLONs use Osram OSLON® SSL LEDs, these are one of the smallest high-power lensed LED on the market today, thus enabling compact LED arrays and maximizing flux over area. Micro OSLONs are compact light sources built on aluminium substrates for optimal thermal management. Available with 200mm wires as standard.

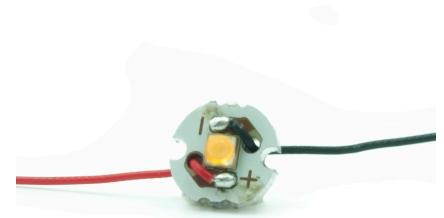

Applications

- General Lighting
- Decorative Lighting
- Task Lighting
- Spot Lighting
- Downlighters
- Retail and Entertainment Lighting

Technical Features

- OSLON®80 1 Micro OSLON®s contain OSLON® SSL 80 LED with integral 80 degree silicon resin Lenses
- Up to 100,000 Hour lifetime to 70% of original brightness
- Size (W x H): 11mmØ x 3.85mm
- Available with 200mm connecting wires
- Secondary Lens can be fitted – check options in suitable Lens and Reflector section
- Suitable Heat Sinks available – check options in Heat Sink section
- Matching Power Supply available - check options in Power Supply section
- Mirco OSLONs can be linked together to produce longer chains
- Current range 100 to 350mA

*This datasheet should be read in conjunction with the relevant OSRAM Opto Semiconductors data on the LED used

Important Information and Precautions

- The Micro OSLOON's LED, when powered up, is very bright. Thus it is advised that you do not look directly at it. Turn the Micro OSLOON's away from you and do not shine into the eyes of others.
- Micro OSLOON's will overheat in operation if not attached to a suitable Heat Sink. Over heating can cause failure or irreparable damage.
- Do not operate Micro OSLOON's with a Power Supply with unlimited current. Connection to constant voltage Power
- Supplies that are not current limited may cause the Micro OSLOON's to consume current above the specified maximum and cause failure or irreparable damage.
- Micro OSLOON's, when operated, can reach high temperatures thus there is risk of injury if they are touched.
- DO NOT HOT PLUG ON LED SIDE OF POWER SUPPLY.
- DO NOT TOUCH or PUSH on the LED as this can cause irreparable damage.

Product Options

ILS PART NUMBER	Colour	Colour Temp* (Degrees Kelvin)	Typical Wattage § at 350mA	Forward Voltage	Flux † at 350mA	Radiance Angle	Relevant OSRAM LED Data
ILM-ON01-FLWH-SC221-WIR200.	Fire Light White	2500K	1.03	2.8-3.25V	97lms	80° (±40°)	GW CS8PM1.EM
ILM-ON01-HWWH-SC221-WIR200.	Hot White	2700K	1.03	2.8-3.25V	104.2lms	80° (±40°)	GW CS8PM1.EM
ILM-ON01-WMWH-SC221-WIR200.	Warm White	3000K	1.03	2.8-3.25V	112lms	80° (±40°)	GW CS8PM1.EM
ILM-ON01-QZWH-SC221-WIR200.	Quartz White	3500K	1.03	2.8-3.25V	112lms	80° (±40°)	GW CS8PM1.EM
ILM-ON01-NUWH-SC221-WIR200.	Neutral White	4000K	1.03	2.8-3.25V	112lms	80° (±40°)	GW CS8PM1.EM
ILM-ON01-MWWH-SC221-WIR200.	Med White	4500K	1.03	2.8-3.25V	112lms	80° (±40°)	GW CS8PM1.EM
ILM-ON01-WHWH-SC221-WIR200.	White	5000K	1.03	2.8-3.25V	112lms	80° (±40°)	GW CS8PM1.EM
ILM-ON01-STWH-SC221-WIR200.	Street White	5700K	1.03	2.8-3.25V	130lms	80° (±40°)	GW CS8PM1.PM
ILM-ON01-ULWH-SC221-WIR200.	Ultra White	6500K	1.03	2.8-3.25V	130lms	80° (±40°)	GW CS8PM1.PM

*Due to the special conditions of the manufacturing processes of LEDs, the typical data of technical parameters can only reflect statistical figures and do not necessarily correspond to the actual parameters of each single product which could differ from the typical data.

§ Tolerance +/- 10%

† Measured with 20mS 350mA pulse at 25 °c

Minimum and Maximum Ratings

ILS PART NUMBER	Operating Temperature at Tc-Point [°C]*	Storage Temperature [°C]*	Forward Current per chip [mA]*	Reverse Voltage [Vdc]*
ILM-ON01-FLWH-SC221-WIR200.	70 °C max	- 40 to 110 °C	1,000mA max	not designed for reverse voltage
ILM-ON01-HWWH-SC221-WIR200.	70 °C max	- 40 to 110 °C	1,000mA max	not designed for reverse voltage
ILM-ON01-WMWH-SC221-WIR200.	70 °C max	- 40 to 110 °C	1,000mA max	not designed for reverse voltage
ILM-ON01-QZWH-SC221-WIR200.	70 °C max	- 40 to 110 °C	1,000mA max	not designed for reverse voltage
ILM-ON01-NUWH-SC221-WIR200.	70 °C max	- 40 to 110 °C	1,000mA max	not designed for reverse voltage
ILM-ON01-MWWH-SC221-WIR200.	70 °C max	- 40 to 110 °C	1,000mA max	not designed for reverse voltage
ILM-ON01-WHWH-SC221-WIR200.	70 °C max	- 40 to 110 °C	1,000mA max	not designed for reverse voltage
ILM-ON01-STWH-SC221-WIR200.	70 °C max	- 40 to 110 °C	1,000mA max	not designed for reverse voltage
ILM-ON01-ULWH-SC221-WIR200.	70 °C max	- 40 to 110 °C	1,000mA max	not designed for reverse voltage

* Exceeding maximum ratings for operating and storage temperature will reduce expected life time or destroy the LED module. Exceeding maximum ratings for operating voltage will cause hazardous overload and will likely destroy the LED module. The temperature of the LED module must be measured at the Tc-Point according to EN60598-1 in a thermally constant status with a temperature sensor or a temperature sensitive label.

Radiation of single LED

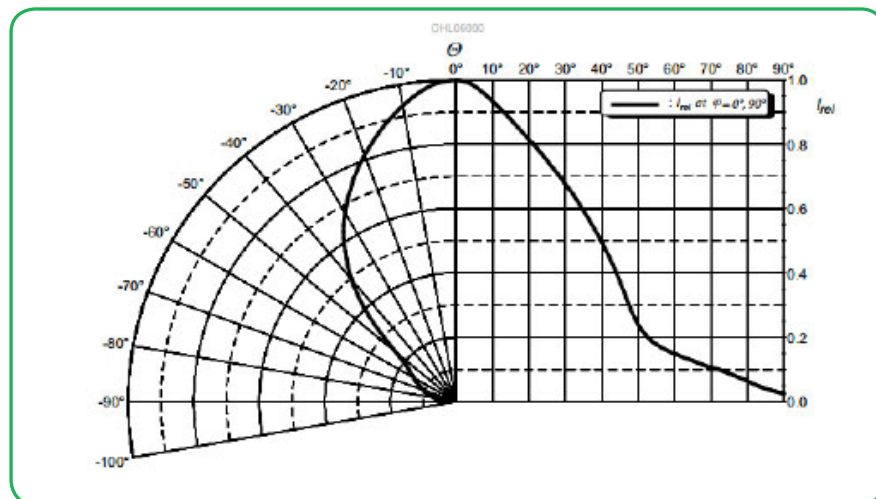

Technical Drawing

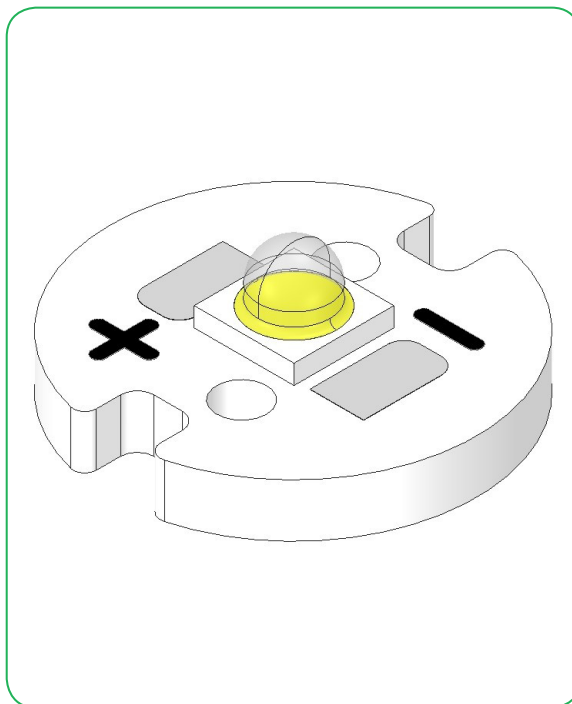
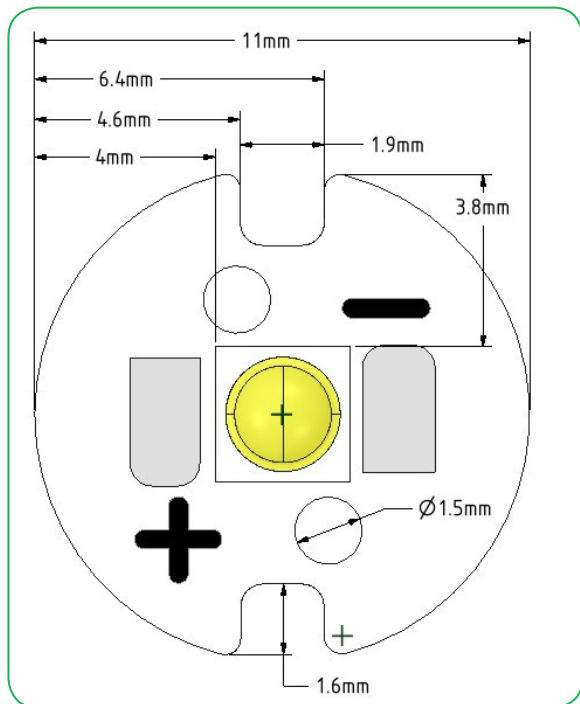

3D drawing files are available on request from ILS. Please call or email

Micro OSLO[®]N Lens and Reflector Options

LEDiL precision-engineered Lenses and Reflectors allow for rapid deployment of all types of light fixtures, including street lights, wall-wash, high-bay, sconces, emergency beacons, parking garage/low-bay, MR and AR downlights, and dock lights. Precision-engineered for maximum efficiency and durability, LEDiL Lenses and Reflectors are released alongside the latest product releases from our LED suppliers. You select the best LED for the application; choose LEDiL and you're selecting the best optical solution as well.



	OSLO [®] N+80	OSLO [®] N+150	OSLO [®] N Square	
LEDiL Part Number	Beam Angle (FWHM)	Beam Angle (FWHM)	Beam Angle (FWHM)	Mounting Type
FP13025_LISA2-W-PIN	N/A	N/A	33	Pin + Glue
FP14414_LISA2-O-PIN	N/A	N/A	47+25	Pin + Glue
FP11001_LISA2-M-PIN	23	25	31	Pin + Glue
FP11002_LISA2-W-PIN	36	46	42	Pin + Glue
FP11003_LISA2-WW-PIN	40	45	48	Pin + Glue
FP11047_LISA2-RS-PIN	16	16	18	Pin + Glue
FP11055_LISA2-RS-PIN	14		18	Pin + Glue
FP11081_LISA2-M-CLIP	23	23	21	Clips
FP11082_LISA2-W-CLIP	36	46	N/A	Clips
FP11083_LISA2-WW-CLIP	N/A	45	N/A	Clips
FP11084_LISA2-RS-CLIP	16	16	N/A	Clips
FP11120_LISA2-O-CLIP	48+19	48+19	N/A	Clips
FP11124_LISA2-O-PIN	48+19	48+19	N/A	Pin + Glue
FP11852_LISA2-O-90-PIN	48+19	48+19	10+40	Pin + Glue
FP11857_LISA2-O-90-CLIP	48+19	48+19	N/A	Clips

	OSLON+80	OSLON+150	OSLON Square	
LEDiL Part Number	Beam Angle (FWHM)	Beam Angle (FWHM)	Beam Angle (FWHM)	Mounting Type
FP11957_LISA2-WWW-PIN	70	91	80	Pin + Glue
FP11958_LISA2-WWW-CLIP	70	94	N/A	Clips
FP13026_LISA2-WW-PIN	N/A	N/A	46	Pin + Glue
FP13028_LISA2-M-PIN	N/A	N/A	26	Pin + Glue
FP13029_LISA2-WW-CLIP	N/A	N/A	46	Clips
FP13030_LISA2-M-CLIP	N/A	N/A	26	Clips
FP13031_LISA2-W-CLIP	N/A	N/A	33	Clips

Reflectors

	OSLON+80	OSLON+150	OSLON Square	
LEDiL Part Number	Beam Angle (FWHM)	Beam Angle (FWHM)	Beam Angle (FWHM)	Mounting Type
C12469_LISA2-R-PIN	76	83	32	Pin + Glue

Micro OSLON® 80 Heat Sink Options

ILS has a series of Aluminium Alloy Heat Sinks to be used with our standard range of PowerStars and PowerClusters. These Heat Sinks are supplied with fixing screws for the light engine and for fixing to a base plate. They also come with Thermal Interface Material (TIM) attached to the top surface. More versions will be introduced over the coming months and we are also happy to manufacture custom Heat Sinks to your request.

ILS Product		No Heat Sink, in free air	ILA-HSINK-10X10X10MM-BLK.
Micro OSLON	100mA	Yellow	Green
	350mA	Yellow	Green
	500mA	Red	Yellow

Green	Operates under the recommended ILS junction temperature
Yellow	Operates under the recommended LED maximum junction temperature
Red	Not suitable for use
N/A	Heat Sink not designed for use with this product

Micro OSLO[®] 80 Power Supply Options

ILS has a comprehensive range of standard Power Supplies. The table below shows the total number of ILS products each Power Supply can drive. Additional Power Supplies are being introduced so please call us or check our website for the latest offering. Please check against the forward voltage of the Micro OSLO before selecting a suitable LED driver.

Constant Current Types

ILS Driver Part Number	Rating Watts	Output	IP Rating	Output Volts	PF	Dimming	
IZC015-005F-0067C-QA	5	150mA	IP67	20-33	0.6	NO	
IZC035-005F-0067C-QA	5	350mA	IP67	2-12	0.6	NO	
IZC070-005F-0067C-QA	5	700mA	IP67	2-5	0.6	NO	
IZC035-008F-5065C-SA	8	350mA	IP65	3-36	0.5	NO	
IZC070-008F-5065C-SA	8	700mA	IP65	3-12	0.5	NO	
IZCXXX-012T-8000-SA	12	350mA - 1050mA	IP20	2-27	0.8	YES	
IZC035-017F-0067A-SA	17	350mA	IP67	6-48	0.6	NO	
IZC035-018T-9500A-SX	18	350mA	IP20	15-52	1	Triac	
IZC050-018T-9500A-SX	18	500mA	IP20	9-36	1	Triac	
IZC070-018T-9500A-SX	18	700mA	IP20	6-26	1	Triac	
IZC035-035F-9067C-QA	35	350mA	IP67	40-50	0.9	NO	
IZC070-035F-0067C-SA	35	700mA	IP67	9-48	0.6	NO	
IZC105-035F-9067C-QA	35	1.05A	IP67	16-32	0.9	NO	

ILS Driver Part Number	Rating Watts	Output	IP Rating	Output Volts	PF	Dimming	
IZC045-040A-9266C-SA	40	450mA	IP66	30-89	0.9	0-10 v	
IZC105-040A-0067C-QA	40	1.05A	IP67	24-40	0	0-10 v	
IZC070-050A-9267C-SA	50	700mA	IP67	24-72	0.9	0-10 v	
IZC050-060F-9067C-QA	60	500mA	IP67	40-110	0.9	NO	
IZC105-060F-9067C-QA	60	1.05A	IP67	30-60	0.9	NO	
IZC140-060F-9067C-QA	60	1.4A	IP67	20-42	0.9	NO	
IZC070-075A-9267C-SA	75	700mA	IP67	54-108	0.9	0-10 v	
IZC140-075F-9067A-QAL	75	1400mA	IP67	30-53	0.9	NO	

Thermal Interface Material Options

ILS have produced a range of high-performance, cost effective Thermal Interface Materials to match perfectly their standard products.

Our product fills the air pockets between the two surfaces, forming a continuous layer to conduct heat away from the LED to the Heat Sink.

Product	TIM Part Number
Micro OSOLON®	ILA-TIM-MICRO-2A

Other sizes are available, including customised parts

Assembly Information

- The mounting of the Micro OSOLON® has to be on a metal Heat Sink.
- In order to optimise the thermal management, the metal surface needs to be clean (dirt and oil free) and planar for the best contact with the LED module. A thermal grease or heat transfer material is highly recommended.

Safety Information

- The LED module itself and all its components must not be mechanically stressed.
- Assembly must not damage or destroy conducting paths on the circuit board.
- The mounting of the module is carried out by attaching it at the mounting holes. Metal mounting screws must be insulated with synthetic washers to prevent circuit board damage and possible short circuiting.
- To avoid mechanical damage to the connecting cables, the boards should be attached securely to the intended substrate. Heavy vibration should be avoided.
- Observe correct polarity!
- Depending on the product, incorrect polarity will lead to emission of red or no light. The module can be destroyed!
- Pay attention to standard ESD precautions when installing the Micro OSOLON®.
- The Micro OSOLON® as manufactured, have no conformal coating and therefore offer no inherent protection against corrosion.
- Damage by corrosion will not be accepted as a materials defect claim. It is the users responsibility to provide suitable protection against corrosive agents such as moisture and condensation and other harmful elements.
- For outdoor usage, a housing is definitely required to protect the board against environmental influences. The design of the housing must correspond to the IP standards in the application. It is also the responsibility of the user to ensure any housings or modifications keep the Tc junction temperature to within stated ranges.
- To also ease the luminaire/installation approval, electronic control gear for LED or LED modules should carry the CE mark and be ENEC certified. In Europe the declarations of conformity must include the following standards: CE: EC 61374-2-13, EN 55015, IEC 61547 and IEC 61000-3-2 - ENEC: 61374-2-13 and IEC/EN 62384.
- The evaluation of eye safety occurs according to the standard IEC 62471:2006 ("photobiological safety of lamps and lamp systems"). Within the risk grouping system of this CIE standard, the LED specified in this data sheet falls into the class "moderate risk" (exposure time 0.25s). Under real circumstances (for exposure time, eye pupils, observation distance), it is assumed that no endangerment to the eye exists from these devices. As a matter of principle, however, it should be mentioned that intense light sources have a high secondary exposure potential due to their blinding effect. As is also true when viewing other bright light sources (e.g. headlights), temporary reduction in visual acuity and afterimages can occur, leading to irritation, annoyance, visual impairment and even accidents, depending on the situation.

For further information please contact ILS

The values contained in this data sheet can change due to technical innovations. Any such changes will be made without separate notification.