

AERD-N1BB/N1CB/N1DB

Infrared SMT Round Lamps

Overview

The new Broadcom[®] surface mount infrared emitter LEDs (IR SMT lamps) elevate Broadcom to the world of infrared sensing. With a state-of-the-art packaging platform and exceptional lens optics profile, the IR SMT lamp is the right solution for a variety of infrared sensing applications such as light curtains, office automation, traffic detection, and industrial sensing.

Besides being packaged in a surface mount platform enabling solder reflow, the IR SMT lamps also offer a multiple range of optics design to address different applications needs. The IR SMT lamp is made with an advanced optical grade epoxy for superior performance in outdoor applications. Package stability and robustness boost the product's reliability to withstand critical outdoor conditions while exhibiting longevity features needed for semiconductor components.

Features

- Clear lens
- Tall package for easier potting
- Low power consumption
- Typical peak wavelength 850 nm
- Typical viewing angle: 18°, 30°, and 40°

Applications

- Light curtain
- Traffic control
- Industrial sensing
- Office automation

CAUTION! The LED must be kept in a moisture barrier bag with <5% relative humidity (RH) when not in use because prolonged exposure to the environment might cause the leads to tarnish or rust, which might cause difficulties in soldering.

Figure 1: Package Drawing

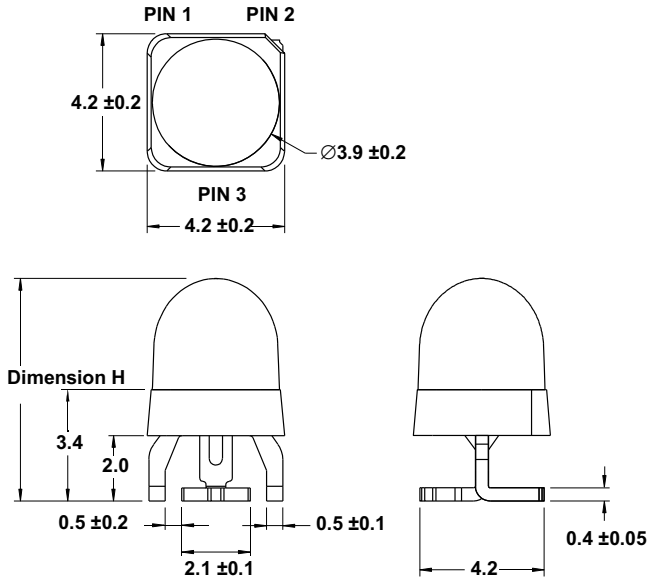

Part Number	Dimension H
AERD-N1BB	7.20
AERD-N1CB	7.05
AERD-N1DB	6.80

Lead Configuration	
Pin 1	Anode
Pin 2	Cathode
Pin 3	Anode

NOTE:

1. All dimensions in millimeters (mm).
2. Tolerance is ± 0.5 mm unless otherwise specified.

Device Selection Guide ($T_J = 25^\circ\text{C}$, $I_F = 100\text{ mA}$)

Part Number	Die Type	Radiant Intensity, I_e (mW/sr) ^{a, b, c}			Viewing Angle, $2\theta_{1/2}$ ($^\circ$) ^d
		Min.	Typ.	Max.	Typ.
AERD-N1BB-00010	AlGaAs	100	200	320	18
AERD-N1CB-00010	AlGaAs	90	140	220	30
AERD-N1DB-00010	AlGaAs	50	85	140	40

- Radiant intensity, I_e is measured at the mechanical axis of the package with a single current pulse condition ($t_p = 20\text{ ms}$).
- The optical axis is closely aligned with the package mechanical axis.
- Tolerance for each bin limit is $\pm 15\%$.
- $\theta_{1/2}$ is the off-axis angle where the luminous intensity is half of the on-axis intensity.

Absolute Maximum Ratings

Parameters	AERD-N1xB	Unit
DC Forward Current ^a	100	mA
Peak Forward Current ^b	1000	mA
Power Dissipation	195	mW
LED Junction Temperature	100	$^\circ\text{C}$
Operating Temperature Range	-40 to +85	$^\circ\text{C}$
Storage Temperature Range	-40 to +100	$^\circ\text{C}$

- Derate linearly as shown in [Figure 4](#).
- Duty factor = 1%, $t_p = 100\ \mu\text{s}$ at $T_S = 25^\circ\text{C}$.

Optical and Electrical Characteristics ($T_J = 25^\circ\text{C}$)

Parameter	Symbol	Min.	Typ.	Max.	Unit	Test Conditions
Radiant Flux ^a	Φ_e	—	58	—	mW	$I_F = 100\text{ mA}$, $t_p = 20\text{ ms}$
Peak Wavelength	λ_{PEAK}	—	850	—	nm	$I_F = 100\text{ mA}$, $t_p = 20\text{ ms}$
Temperature Coefficient of Brightness	TC_{I_e}	—	-0.38	—	$\%/^\circ\text{C}$	$I_F = 100\text{ mA}$
Temperature Coefficient of λ_p	TC_{λ_p}	—	0.27	—	$\text{nm}/^\circ\text{C}$	$I_F = 100\text{ mA}$
Spectral Line Half-Width	$\Delta\lambda_{1/2}$	—	37	—	nm	$I_F = 100\text{ mA}$, $t_p = 20\text{ ms}$
Forward Voltage ^b	V_F	—	1.60	1.95	V	$I_F = 100\text{ mA}$
Temperature Coefficient of V_F	TC_{V_F}	—	-1.62	—	$\text{mV}/^\circ\text{C}$	$I_F = 100\text{ mA}$
Reverse Voltage ^c	V_R	5	—	—	V	$I_R = 10\ \mu\text{A}$
Rise Time	t_r	—	15	—	ns	$I_F = 100\text{ mA}$
Fall Time	t_f	—	16	—	ns	$I_F = 100\text{ mA}$
Thermal Resistance	$R\theta_{J-S}$	—	270	—	$^\circ\text{C}/\text{W}$	LED junction to pin

- The radiant flux, Φ_e , is the total flux output as measured with an integrating sphere at a single current pulse condition ($t_p = 20\text{ ms}$).
- Forward voltage tolerance is $\pm 0.1\text{V}$.
- Indicates product final test condition. Long-term reverse bias is not recommended.

Figure 2: Relative Radiant Intensity vs. Mono Pulse Current

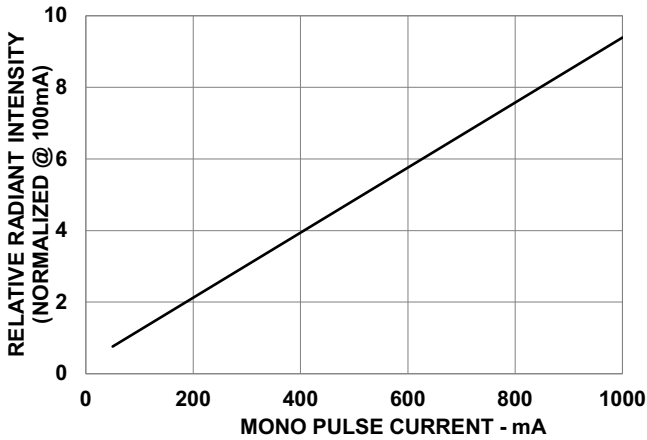

Figure 3: Forward Current vs. Forward Voltage

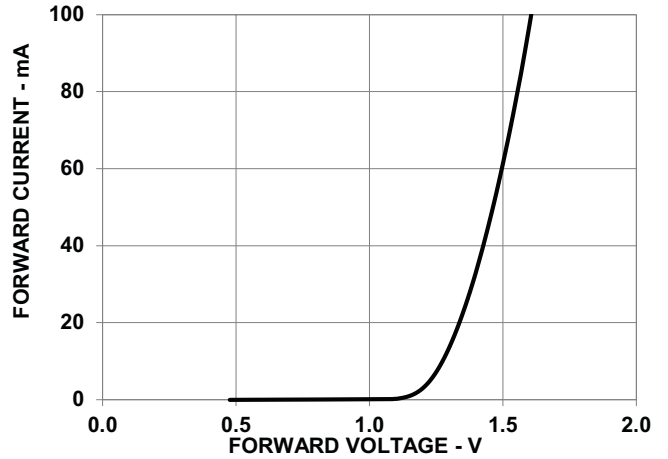

Figure 4: Maximum Forward Current vs. Ambient Temperature

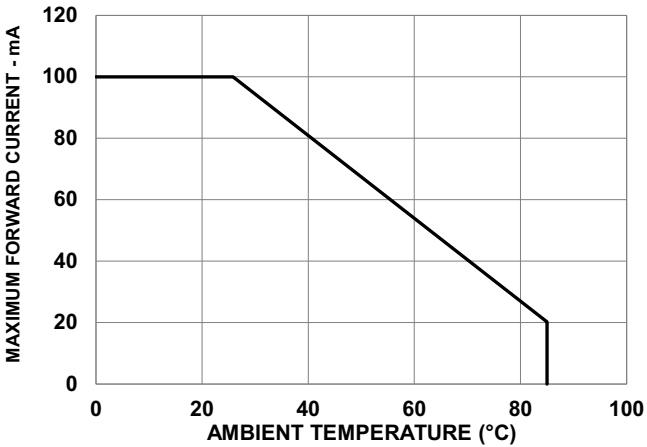

Figure 5: Radiation Pattern

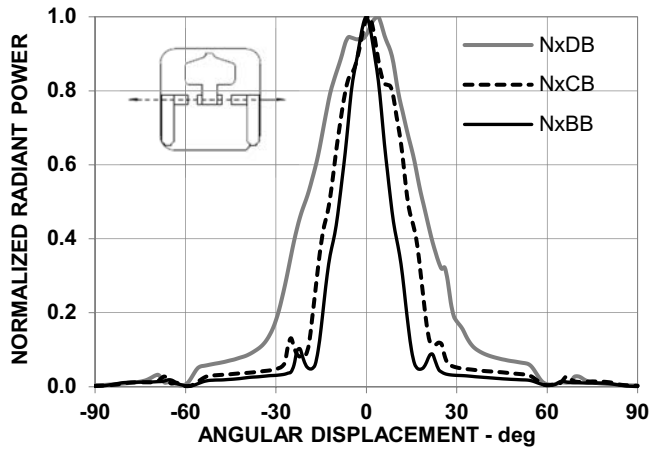

Figure 6: Spectral Distribution

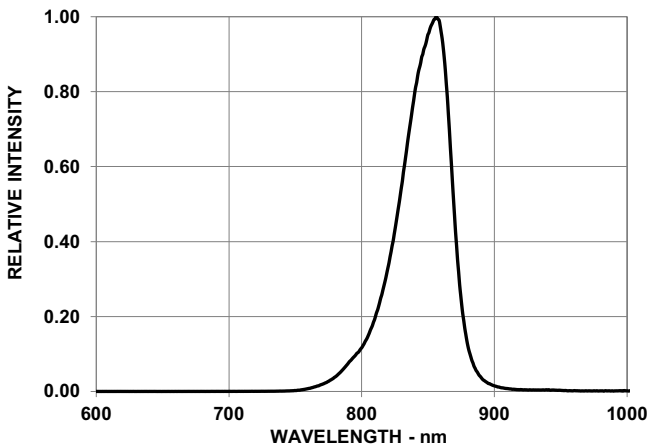
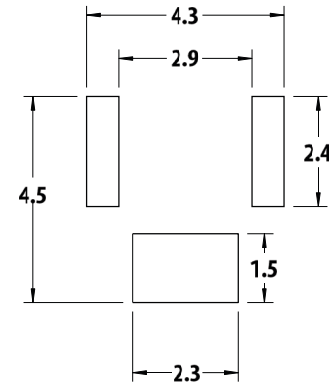
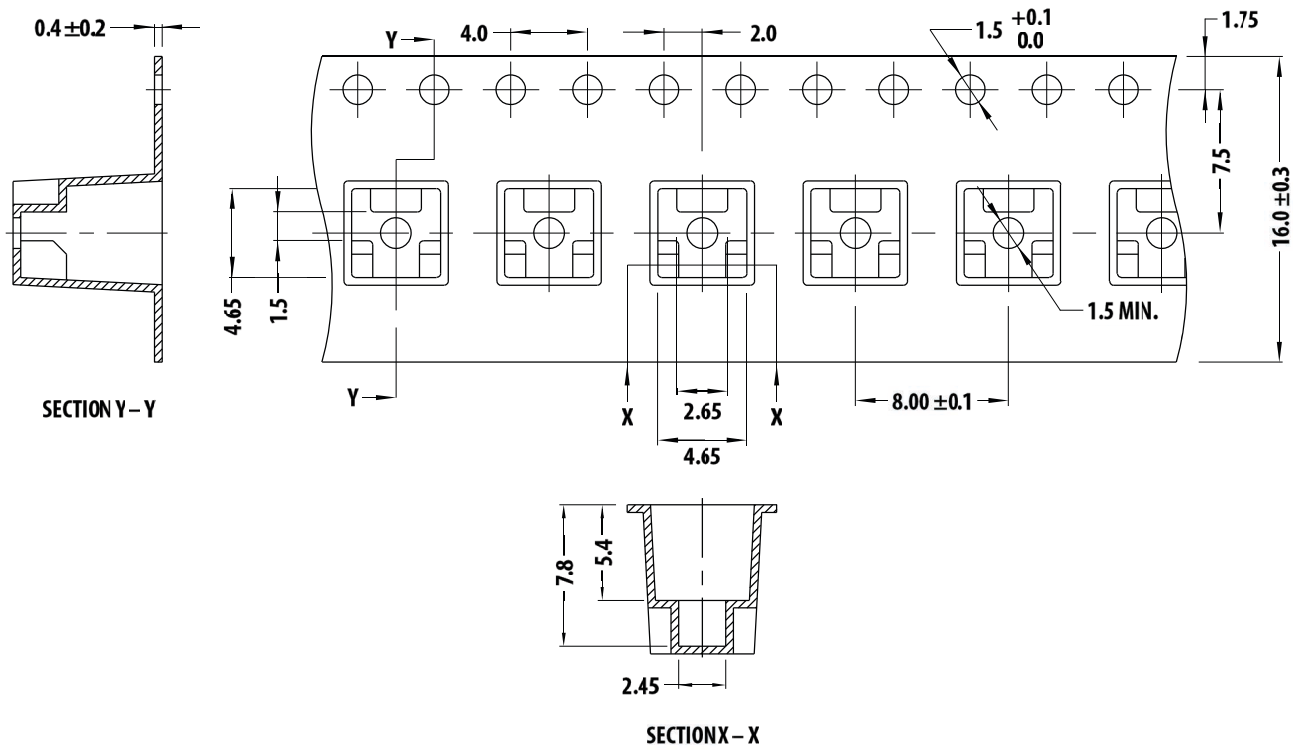

Figure 7: Recommended Soldering Land Pattern



NOTE: All dimensions are in millimeters (mm). Recommended stencil thickness is 0.1524 mm (6 mil) minimum and above.

Figure 8: Carrier Tape Dimensions



NOTE:

1. All dimensions in millimeters (mm).
2. Tolerance is ± 0.20 mm unless otherwise specified.

Figure 9: Reel Dimensions

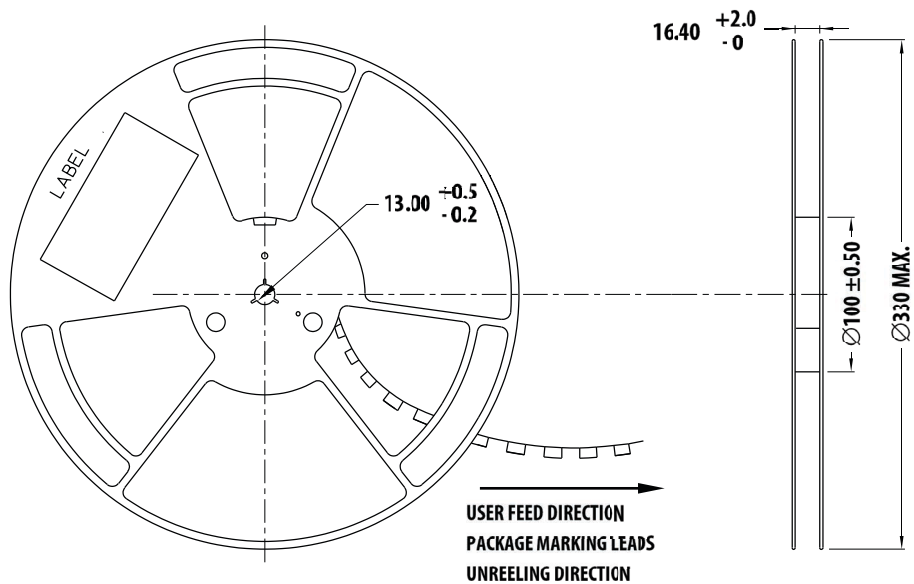

Precautionary Notes

Soldering

- Do not perform reflow soldering more than twice.
- Do not apply any pressure or force on the LED during reflow and after reflow when the LED is still hot.
- Use reflow soldering to solder the LED. Use hand soldering only for rework if unavoidable, but it must be strictly controlled to the following conditions:
 - Soldering iron tip temperature = 315°C maximum.
 - Soldering duration = 3 seconds maximum.
 - Number of cycles = 1 only.
 - Power of soldering iron = 50W maximum.
- Do not touch the LED package body with the soldering iron except for the soldering terminals, as it may cause damage to the LED.
- Confirm beforehand whether the functionality and performance of the LED is affected by soldering with hand soldering.

Figure 10: Recommended Lead-Free Reflow Soldering Profile

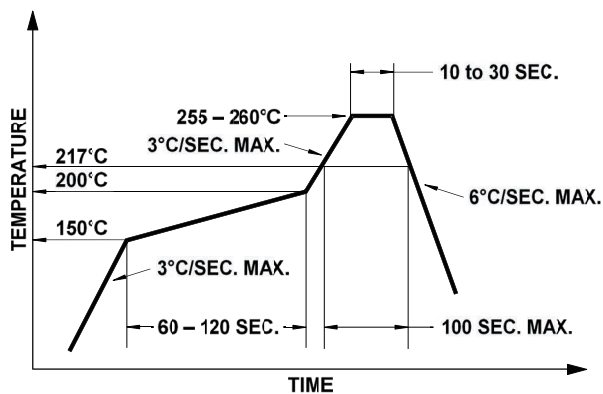

Handling Precautions

For automated pick and place, Broadcom has tested following nozzle size to work with this LED. However, due to the possibility of variations in other parameters such as pick and place machine maker/model, and other settings of the machine, verify that the selected nozzle performs as per requirements.

Figure 11: Recommended Nozzle Dimension

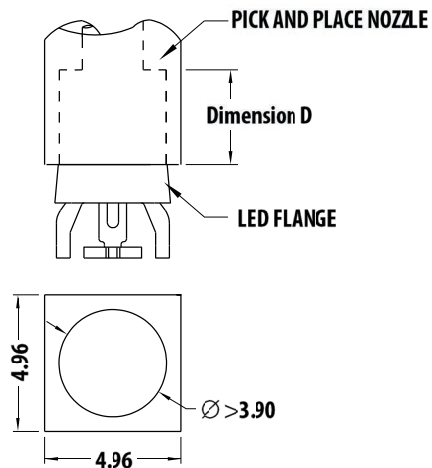

Part Number	Dimension D -mm
AERD-N1BB	>4.30
AERD-N1CB	>4.15
AERD-N1DB	>3.90

Handling of Moisture-Sensitive Devices

This product has a Moisture Sensitive Level 3 rating per JEDEC J-STD-020. Refer to Broadcom Application Note AN5305, *Handling of Moisture Sensitive Surface Mount Devices*, for additional details and a review of proper handling procedures.

- Before use:
 - An unopened moisture barrier bag (MBB) can be stored at $40^{\circ}\text{C}/90\% \text{RH}$ for 12 months. If the actual shelf life has exceeded 12 months and the Humidity Indicator Card (HIC) indicates that baking is not required, then it is safe to reflow the LEDs per the original MSL rating.
 - Do not open the MBB prior to assembly (for example, for IQC). If unavoidable, MBB must be properly resealed with fresh desiccant and HIC. The exposed duration must be taken in as floor life.
- Control after opening the MBB:
 - Read the HIC immediately upon opening of MBB.
 - Keep the LEDs at $30^{\circ}\text{C}/60\% \text{RH}$ at all times, and complete all high temperature-related processes, including soldering, curing, or rework within 168 hours.
- Control for unfinished reel:

Store unused LEDs in a sealed MBB with desiccant or a desiccator at $5\% \text{RH}$.
- Control of assembled boards:

If the PCB soldered with the LEDs is to be subjected to other high-temperature processes, store the PCB in a sealed MBB with desiccant or desiccator at $5\% \text{RH}$ to ensure that all LEDs have not exceeded their floor life of 168 hours.
- Baking is required if:
 - The HIC indicator indicates a change in color for 10% and 5%, as stated on the HIC.
 - The LEDs are exposed to conditions of $30^{\circ}\text{C}/60\% \text{RH}$ at any time.
 - The LED's floor life exceeded 168 hours.

The recommended baking condition is $60^{\circ}\text{C} \pm 5^{\circ}\text{C}$ for 20 hours.

Baking can only be done once.
- Storage:

The soldering terminals of these Broadcom LEDs are silver plated. If the LEDs are exposed in ambient environment for too long, the silver plating might be oxidized, thus affecting its solderability performance. As such, keep unused LEDs in a sealed MBB with desiccant or in a desiccator at $5\% \text{RH}$.

Application Precautions

- The drive current of the LED must not exceed the maximum allowable limit across temperature as stated in the data sheet. Constant current driving is recommended to ensure consistent performance.
- Circuit design must cater to the whole range of forward voltage (V_F) of the LEDs to ensure the intended drive current can always be achieved.
- The LED exhibits slightly different characteristics at different drive currents, which can result in a larger variation of performance (meaning: intensity, wavelength, and forward voltage). Set the application current as close as possible to the test current to minimize these variations.
- The LED is not intended for reverse bias. Use other appropriate components for such purposes. When driving the LED in matrix form, ensure that the reverse bias voltage does not exceed the allowable limit of the LED.
- Avoid rapid changes in ambient temperature, especially in high-humidity environments, because they cause condensation on the LED.
- If the LED is intended to be used in harsh or outdoor environment, protect the LED against damages caused by rain water, water, dust, oil, corrosive gases, external mechanical stresses, and so on.

Thermal Management

Optical, electrical, and reliability characteristics of the LED are affected by temperature. Keep the junction temperature (T_J) of the LED below the allowable limit at all times. T_J can be calculated as follows:

$$T_J = T_A + R_{\theta_{J-A}} \times I_F \times V_{F_{max}}$$

where:

T_A = ambient temperature ($^{\circ}\text{C}$).

$R_{\theta_{J-A}}$ = thermal resistance from LED junction to ambient ($^{\circ}\text{C}/\text{W}$).

I_F = forward current (A).

$V_{F_{max}}$ = maximum forward voltage (V).

The complication of using this formula lies in T_A and $R_{\theta_{J-A}}$. Actual T_A is sometimes subjective and hard to determine. $R_{\theta_{J-A}}$ varies from system to system depending on design and is usually not known.

Another way of calculating T_J is by using the solder point temperature, T_S , as follows:

$$T_J = T_S + R_{\theta_{J-S}} \times I_F \times V_{F_{max}}$$

where:

T_S = LED solder point temperature as shown in [Figure 12](#) ($^{\circ}\text{C}$).

$R_{\theta_{J-S}}$ = thermal resistance from junction to solder point ($^{\circ}\text{C}/\text{W}$).

I_F = forward current (A).

$V_{F_{max}}$ = maximum forward voltage (V).

Figure 12: Solder Point Temperature on PCB

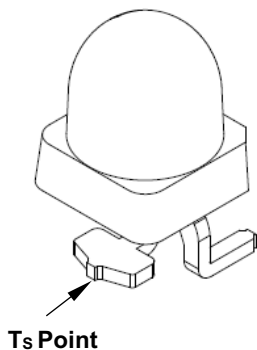

T_S can be easily measured by mounting a thermocouple on the soldering joint as shown in [Figure 12](#), while $R_{\theta_{J-S}}$ is provided in this data sheet. Verify the T_S of the LED in the final product to ensure that the LEDs are operating within all maximum ratings stated in this data sheet.

Eye Safety Precautions

LEDs may pose optical hazards when in operation. Do not look directly at operating LEDs because it might be harmful to the eyes. For safety reasons, use appropriate shielding or personal protective equipment.

Disclaimer

Broadcom's products and software are not specifically designed, manufactured, or authorized for sale as parts, components, or assemblies for the planning, construction, maintenance, or direct operation of a nuclear facility or for use in medical devices or applications. The customer is solely responsible, and waives all rights to make claims against Broadcom or its suppliers, for all loss, damage, expense, or liability in connection with such use.

Broadcom, the pulse logo, Connecting everything, Avago Technologies, Avago, and the A logo are among the trademarks of Broadcom and/or its affiliates in the United States, certain other countries, and/or the EU.

Copyright © 2021 Broadcom. All Rights Reserved.

The term "Broadcom" refers to Broadcom Inc. and/or its subsidiaries. For more information, please visit www.broadcom.com.

Broadcom reserves the right to make changes without further notice to any products or data herein to improve reliability, function, or design. Information furnished by Broadcom is believed to be accurate and reliable. However, Broadcom does not assume any liability arising out of the application or use of this information, nor the application or use of any product or circuit described herein, neither does it convey any license under its patent rights nor the rights of others.

