



TAOGLAS®



Datasheet

Universe

Part No:
PCS.60.A

Description:

Low Profile Cellular 5G/4G/3G & GNSS SMD Antenna

Features:

SMD Dielectric Antenna

5G/LTE: 600-6000MHz

GPS / GLONASS / Galileo / BeiDou (1561-1602MHz)

Adjusts the resonance frequency of the antenna to the desired frequency band

Dimensions: 38*10*1.6mm

Smart antenna solution with aperture tuning

RoHS & REACH Compliant

1. Introduction	3
2. Operational Instructions of the PCSD.60.A	5
3. Specifications	7
4. Antenna Characteristics	9
5. Radiation Patterns	11
6. Mechanical Drawing	26
7. Antenna Integration Guide	27
<hr/>	
8. Packaging	34
<hr/>	
9. Application Note	36
<hr/>	
10. Solder Reflow Recommendations	39
<hr/>	
Changelog	40

Taoglas makes no warranties based on the accuracy or completeness of the contents of this document and reserves the right to make changes to specifications and product descriptions at any time without notice. Taoglas reserves all rights to this document and the information contained herein. Reproduction, use or disclosure to third parties without express permission is strictly prohibited.



1. Introduction



The Taoglas Universe PCS.60A is a patent pending active Cellular and GNSS antenna designed specifically for IoT devices with small ground planes. With an unprecedented level of integration, it combines aperture tuning and active switching technologies to provide a wideband coverage for GNSS and most 5G/4G LTE cellular bands, including the most challenging 600-700MHz bands like band 71 commonly used in US applications.

The PCS.60.A has an RF switch to adjust the resonance frequency of the antenna depending on the device requirements. The aperture tuning technology allows the antenna to cover the whole spectrum of 5G/4G LTE bands by adjusting the resonant frequency of the antenna to the desired frequency band of operation. This allows the device to use the correct frequency band required by the radio module. Additionally, a second active switch can be simply added if either Cellular or GNSS needs to be selected. *

The PCS.60.A is compatible with the radio modules that support RF front end control interface (RFFE). The radio module controls the active RF switch to adjust the antenna resonance frequency to operate efficiently on multiple bands and increasing the RF capabilities by 3dB compared with standard passive solutions. This will in turn improve the Total Radiated Power (TRP) and Total Isotropic Sensitivity (TIS).

The PCS.60.A is easy to integrate using standard SMD technologies, and implementing the active solution is easy thanks to Taoglas' integration support, providing different design files depending on your requirements. The antenna can be tuned by simply selecting the best switching the configuration to achieve the optimum antenna performance.

Please see section 2 of this datasheet for the key operational instructions of this antenna to ensure optimum performance. Section 3, 4 and 5 of this datasheet shows the PCS.60.A antenna performance on Taoglas evaluation board PCSD.60A. Section 7 shows the general rules to implement the antenna and the Application Note in Section 9 demonstrates how to integrate the smart antenna solution into your device.

The PCS.60.A, tuned for PCBs to a size of just 40 x 70m, makes it suitable for even the smallest of IoT and CAT-M devices. Typical applications include IoT devices such as smart sensors requiring cellular and GNSS connectivity, wearables or asset tracking. The antenna itself measures just 38 x 10 x 1.6mm and as it is manufactured from high grade FR4 PCB, it is lightweight, yet robust and it is supplied on tape and reel.

Contact your regional Taoglas customer support team for quick and professional support from our senior engineering team on integration and matching of the antenna to your device.

*Depending on the capabilities of the radio module used.

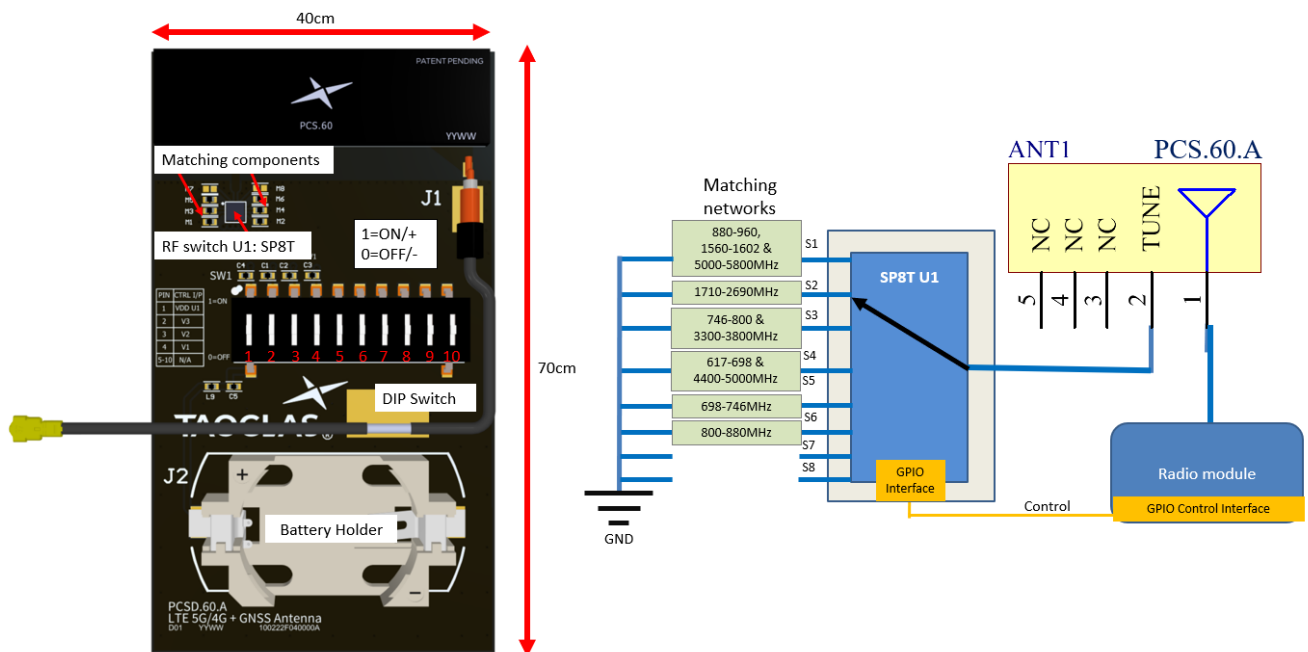

2. Operational Instructions of the PCSD.60.A

Taoglas developed an evaluation board called PCSD.60.A that includes the PCS.60.A antenna, a RF switch and other components to operate this smart antenna solution. This is available to order from Taoglas. Taoglas developed this EVB to help customers in implementing this solution on their application. The evaluation kit uses a simple RF switch SP8T to select different matching circuits.

The RF switches used in the evaluation kit are:

SP8T: Infineon [BGS18GA14](#)

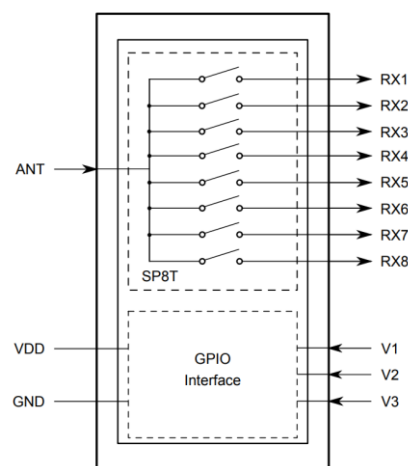
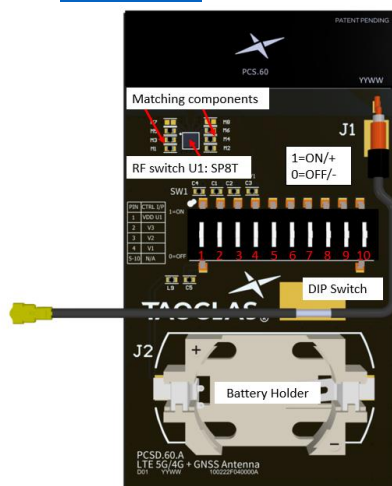

In the evaluation kit, A RF Switch is controlled by the DIP switch, representing the control interface of the radio module. The DIP switch is connected to a 3V coin battery (CR02032, need to buy separately).

The DIP switch has two states: 1 represents ON, 0 represents OFF.

The DIP switch is a 10 way switch, numbered 1 to 10.

- Pins 1-4 are used to control the SP8T (U1):
 - Pin 1 controls the power to SP8T (VDD),
 - Pin 2 controls V3 on the RF switch,
 - Pin 3 controls V2 on the RF switch,
 - Pin 4 controls V1 on the RF switch.

- Pin 5-10 are not connected and therefore not used.

PIN 1=VDD	Pin 4=V1	Pin 3=V2	Pin2=V3	SP8T State
1	0	0	0	S1: M1-ANT
1	0	0	1	S2:M2-ANT
1	0	1	0	S3:M3-ANT
1	0	1	1	S4:M4-ANT
1	1	0	1	S5:M5-ANT
1	1	1	0	S6:M6-ANT

The pin definition and control table is shown in the table above.

2.1 Antenna Active Tuning Circuit

Below is the Schematic of the PCSD.60.A using SP8T.

For the current setup, only the first 6 states, State 1 to State 6 (S1-S6), of the SP8T are used. The other 2 states are reserved for future applications.

Six sets of matching circuits are placed after the SP8T RX1-RX6. The antenna performance is tested and recorded when each of them are connected.

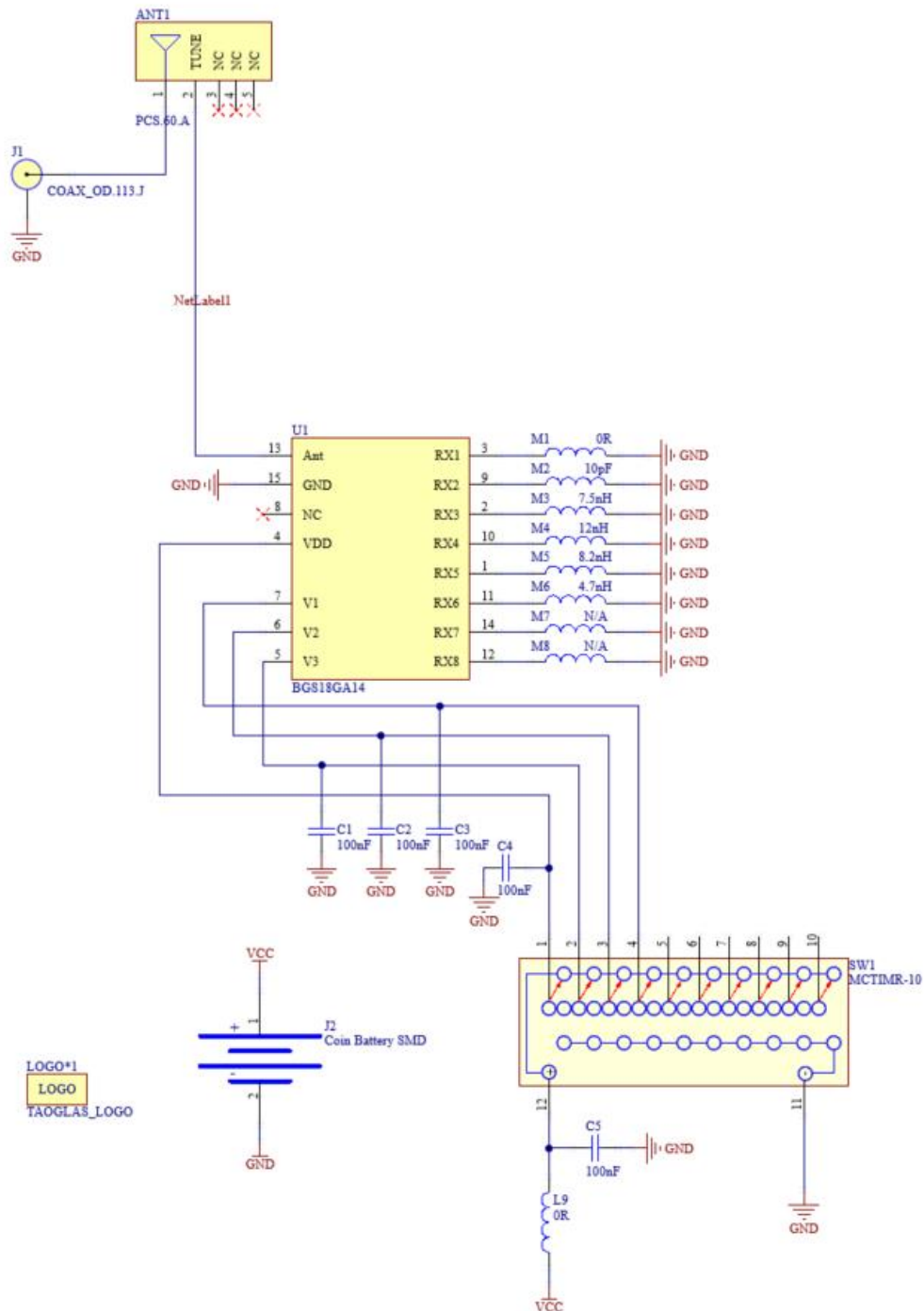

3. Specifications

Electrical								
Band	Frequency (MHz)	State	Efficiency (%)	Average Gain (dB)	Peak Gain (dBi)	Polarization	Impedance	Max Input Power
5G NR Band 71	617~698	S4	15	-8.0	-2.6	Linear	50Ω	5W
5G NR/4G Band 12,17,28,29,85	698~746	S5	21	-6.8	-2.1			
5G NR/4G Band 13,14,20,28	746~800	S3	25	-6.1	-1.2			
5G NR/4G Band 5,18,19,20,26,27	800~880	S6	27	-5.7	-0.8			
5G NR/4G Band 5,8,19,26	880~960	S1	27	-5.5	-0.5			
4G/3G Band 1,2,3,4,9,23,25,35,39,66	1710~2690	S2	65	-1.89	4.79			
5G NR Band 78	3300~3800	S3	64	-1.94	4.71			
5G NR Band 79	4400~5000	S4	61	-2.15	2.84			
5G NR Band 46	5000-5800	S1	44	-3.58	3.99			
GNSS	1560-1602	S1	62	-2.08	2.81			
Mechanical								
Antenna Dimensions	38 x 10 x 1.6mm							
Material	FR4							
Weight	-							
Soldering Type	SMT							
Environmental								
Operation Temperature	-40°C ~ +85°C							
Storage Temperature	-40°C ~ +85°C							
Moisture Sensitivity Level	3							

Results are based on the Evaluation board of 40mm x 70mm with ground plane length of 55 mm. The antenna efficiency values meet operator requirement for USA markets for CATM1 cellular technology.

*Results are shown using the optimum state of the antenna on the evaluation board.

5G/4G Bands			
Band Number	5G NR / FR1 / LTE / LTE-Advanced / WCDMA / HSPA / HSPA+ / TD-SCDMA		
	Uplink	Downlink	Covered
1	UL: 1920 to 1980	DL: 2110 to 2170	✓
2	UL: 1850 to 1910	DL: 1930 to 1990	✓
3	UL: 1710 to 1785	DL: 1805 to 1880	✓
4	UL: 1710 to 1755	DL: 2110 to 2155	✓
5	UL: 824 to 849	DL: 869 to 894	✓
7	UL: 2500 to 2570	DL: 2620 to 2690	✓
8	UL: 880 to 915	DL: 925 to 960	✓
9	UL: 1749.9 to 1784.9	DL: 1844.9 to 1879.9	✓
11	UL: 1427.9 to 1447.9	DL: 1475.9 to 1495.9	✗
12	UL: 699 to 716	DL: 729 to 746	✓
13	UL: 777 to 787	DL: 746 to 756	✓
14	UL: 788 to 798	DL: 758 to 768	✓
17	UL: 704 to 716	DL: 734 to 746	✓
18	UL: 815 to 830	DL: 860 to 875	✓
19	UL: 830 to 845	DL: 875 to 890	✓
20	UL: 832 to 862	DL: 791 to 821	✓
21	UL: 1447.9 to 1462.9	DL: 1495.9 to 1510.9	✗
22	UL: 3410 to 3490	DL: 3510 to 3590	✓
23	UL: 2000 to 2020	DL: 2180 to 2200	✓
24	UL: 1625.5 to 1660.5	DL: 1525 to 1559	✓
25	UL: 1850 to 1915	DL: 1930 to 1995	✓
26	UL: 814 to 849	DL: 859 to 894	✓
27	UL: 807 to 824	DL: 852 to 869	✓
28	UL: 703 to 748	DL: 758 to 803	✓
29	UL: -	DL: 717 to 728	✓
30	UL: 2305 to 2315	DL: 2350 to 2360	✓
31	UL: 452.5 to 457.5	DL: 462.5 to 467.5	✗
32	UL: -	DL: 1452 - 1496	✗
35		1850 to 1910	✓
38		2570 to 2620	✓
39		1880 to 1920	✓
40		2300 to 2400	✓
41		2496 to 2690	✓
42		3400 to 3600	✓
43		3600 to 3800	✓
46/47		5150 to 5925	✓
48		3550 to 3700	✓
66	UL: 1710-1780	DL: 2110-2200	✓
71		617 to 698	✓
74/75/76		1427 to 1518	✗
77/78		3300 to 4200	✓
79		4400 to 5000	✓
85	698-716	728-746	✓

4. Antenna Characteristics

4.1 Return Loss

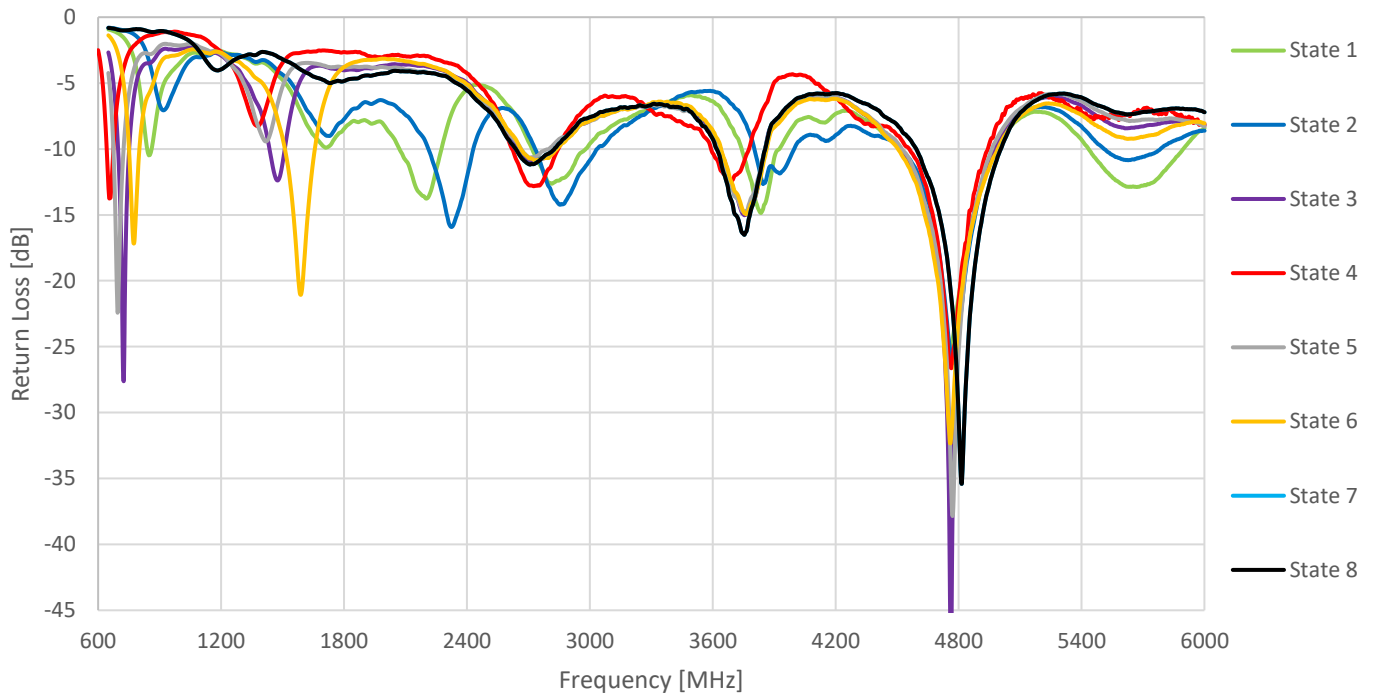

4.2 Efficiency

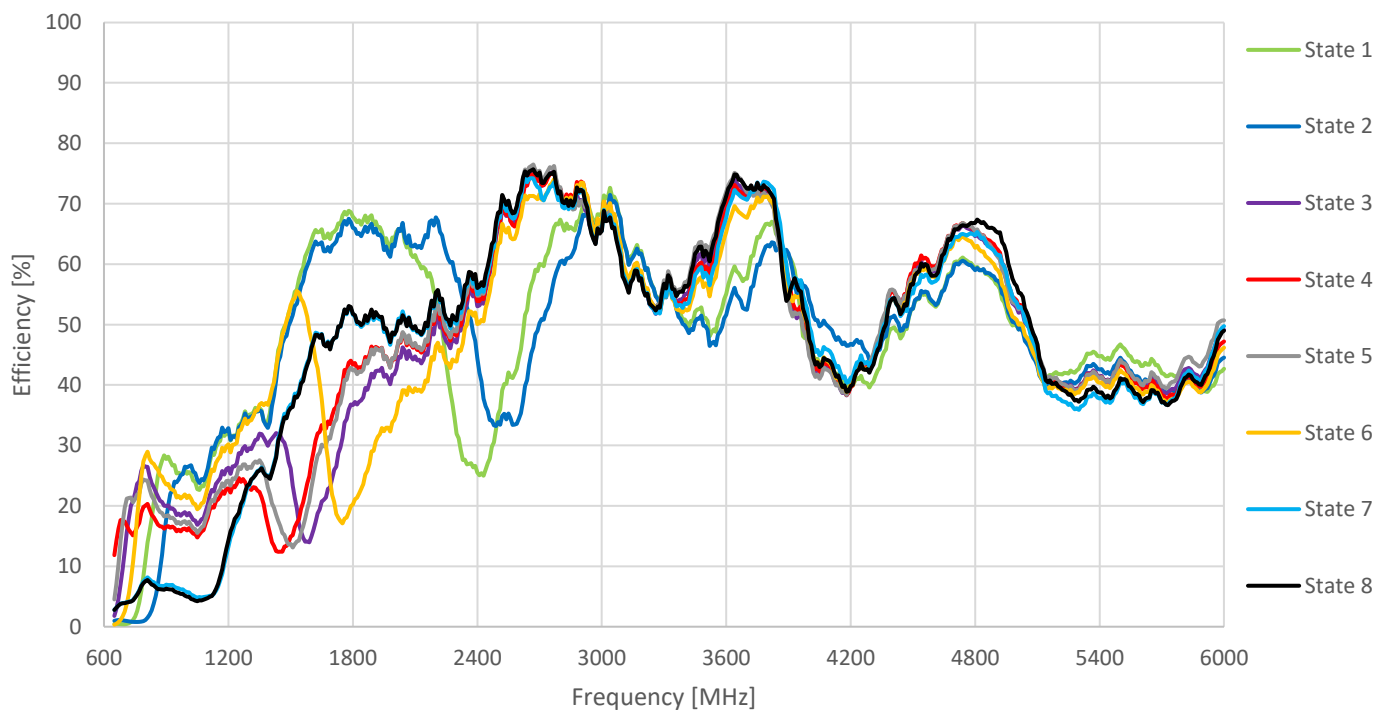

4.3 Peak Gain

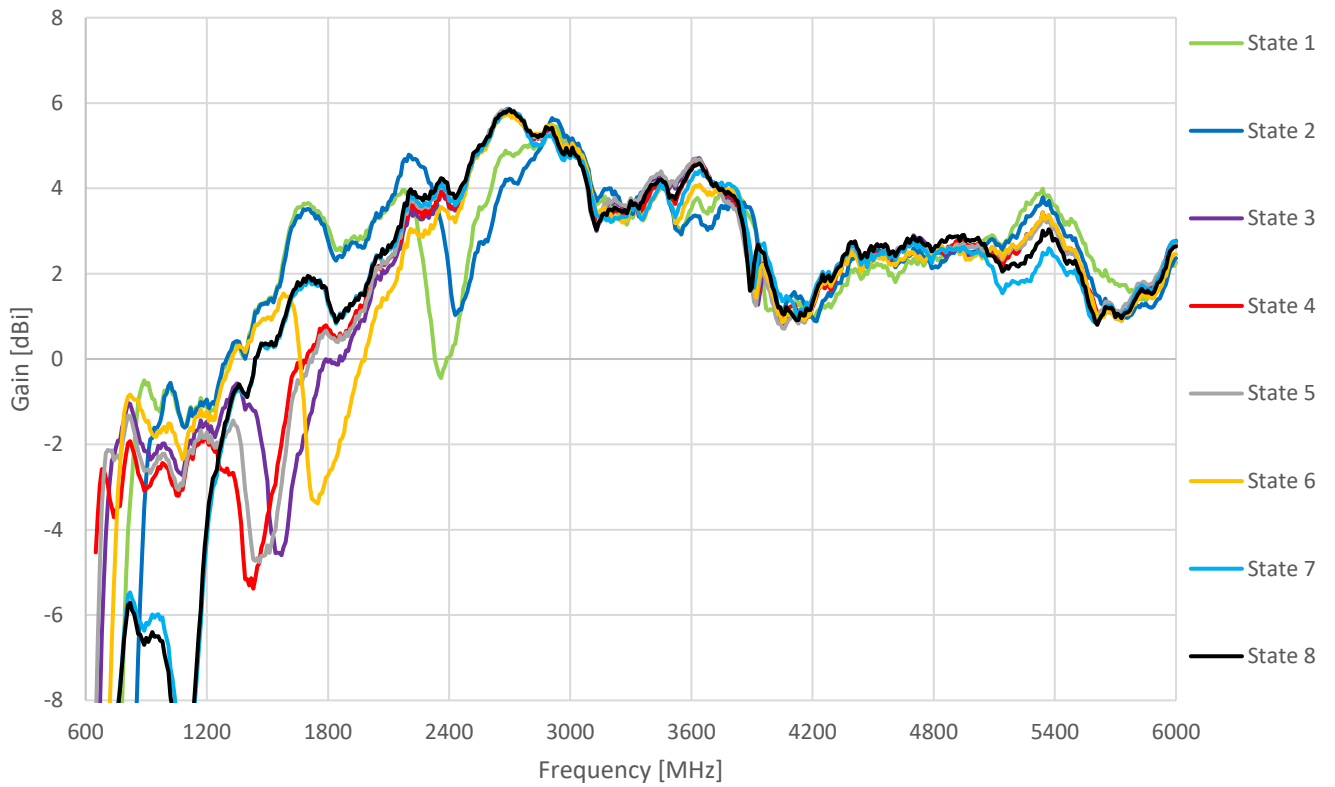

4.4 Average Gain

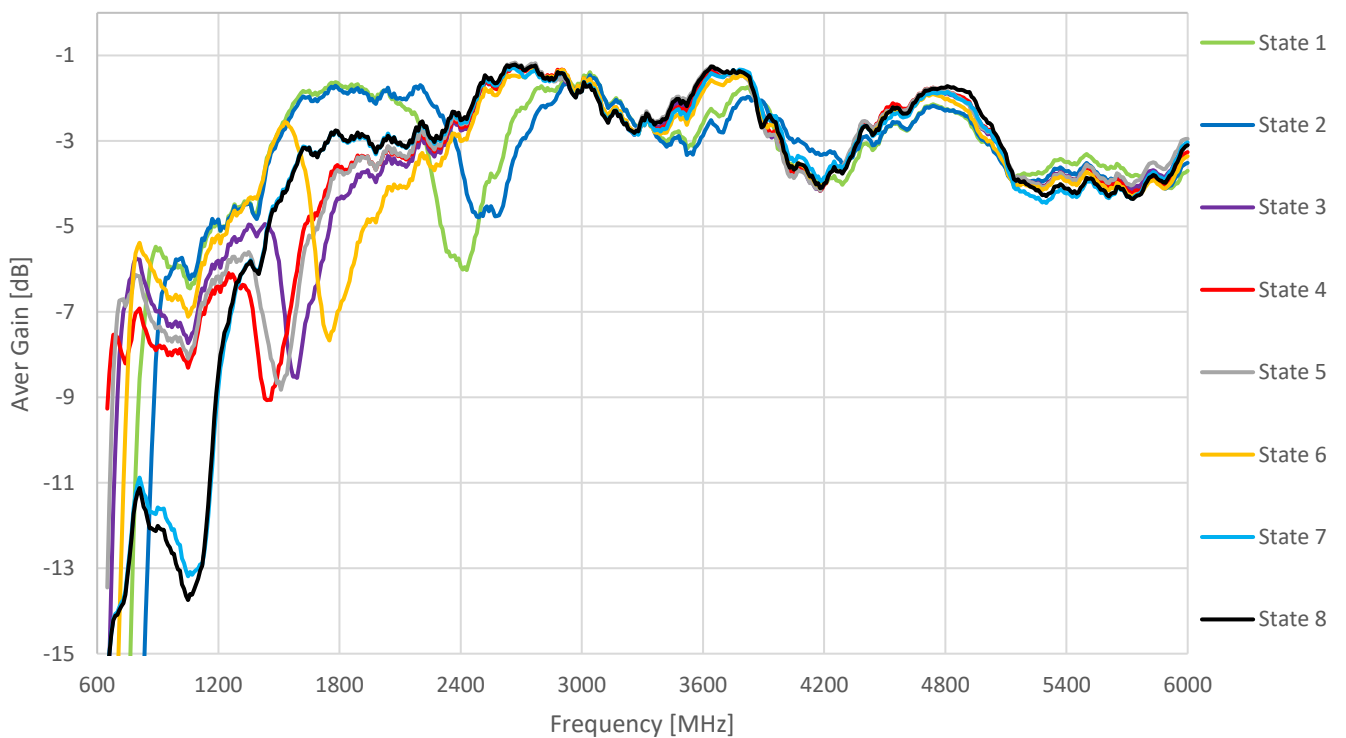

5. Radiation Patterns

5.1 Test Setup



5.2 650MHz 3D and 2D Radiation Patterns

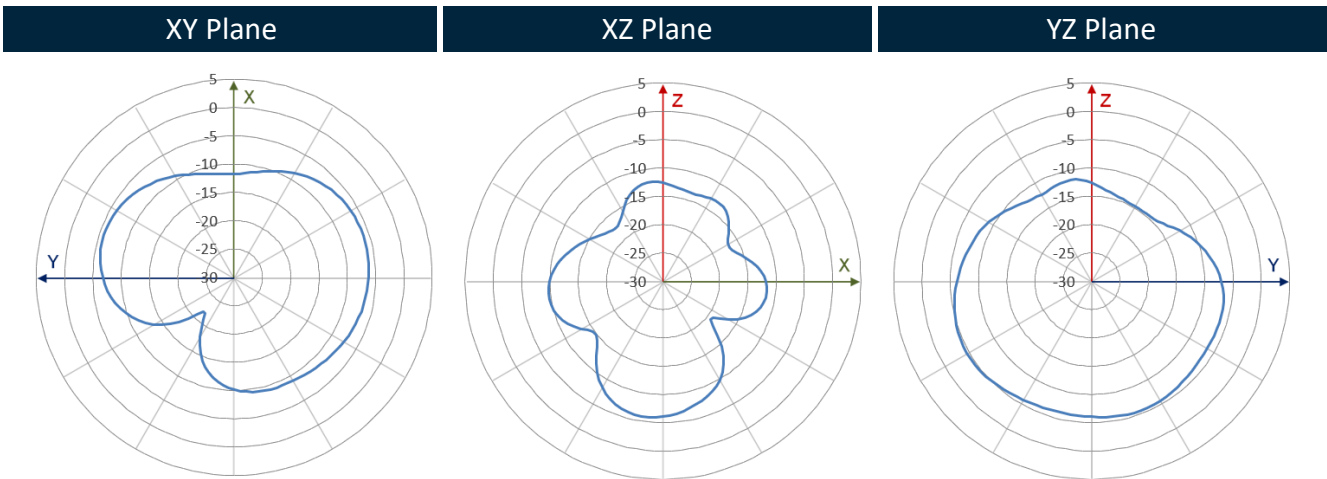
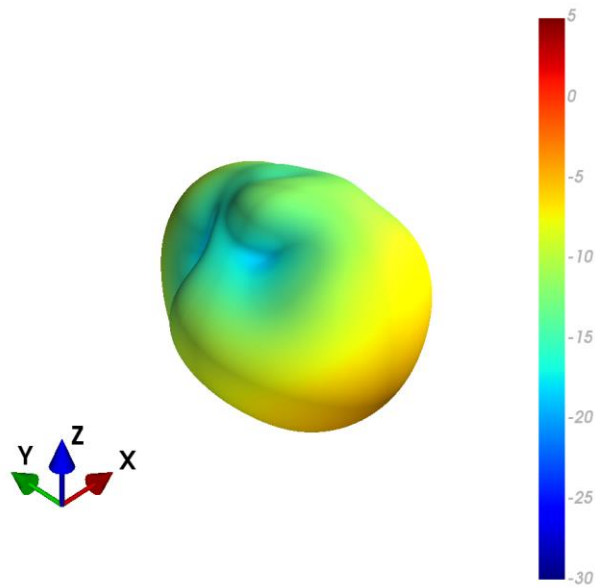

700MHz

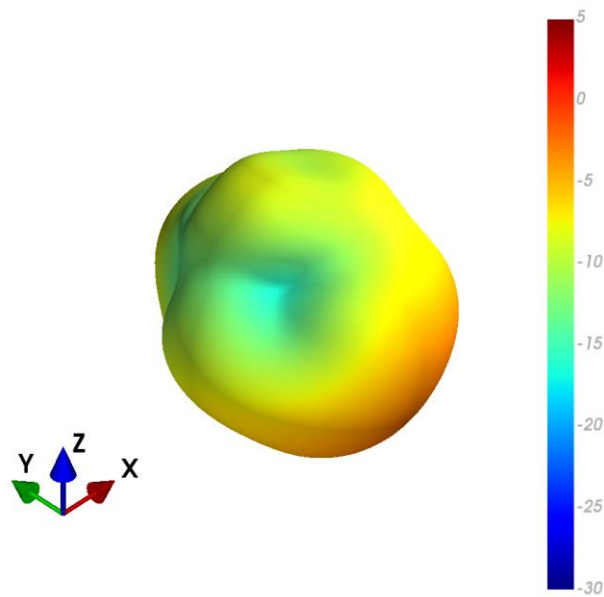

XY Plane

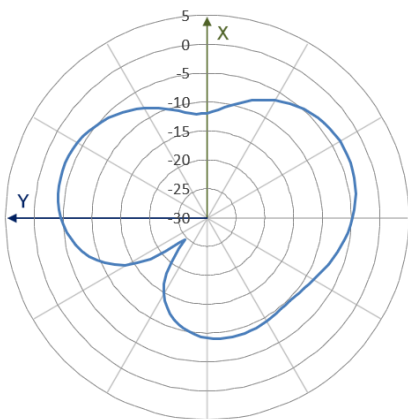

XZ Plane

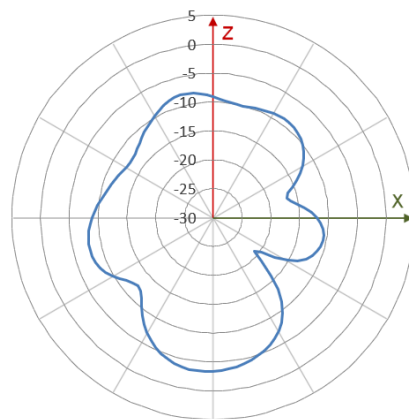

YZ Plane

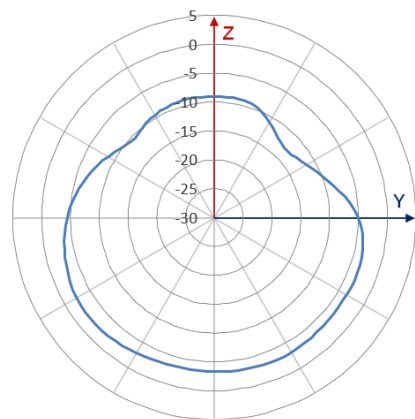

800MHz

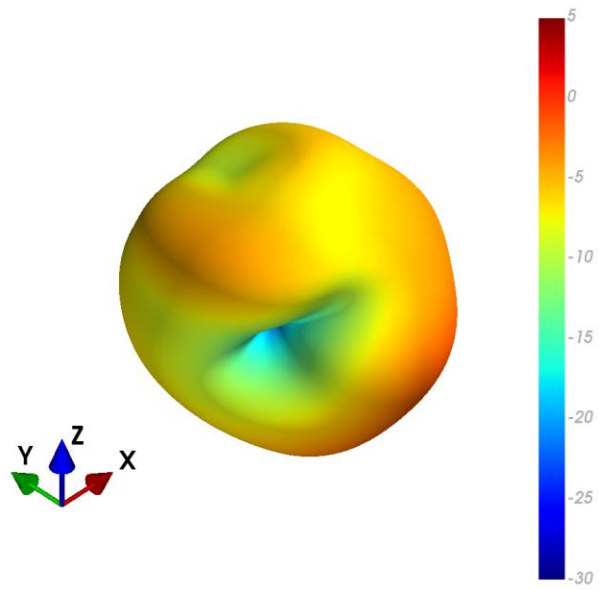

XY Plane

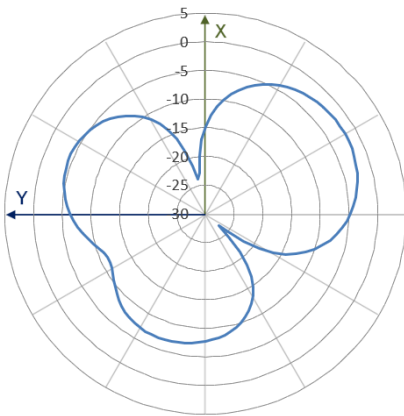

XZ Plane

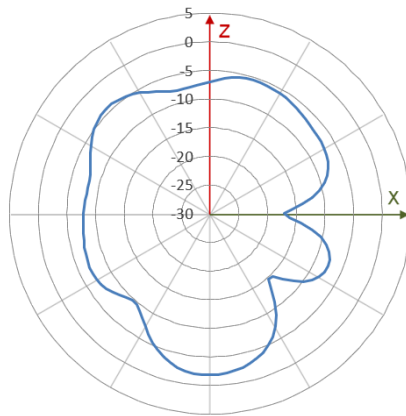

YZ Plane

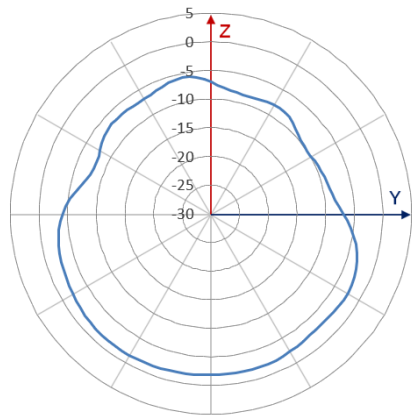

900MHz

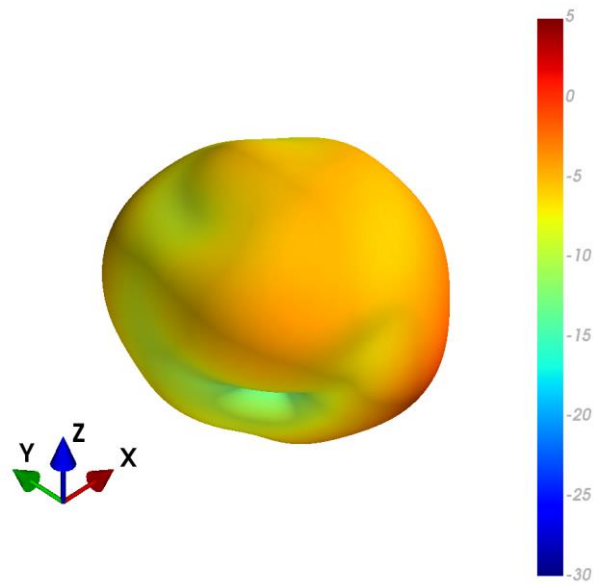

XY Plane

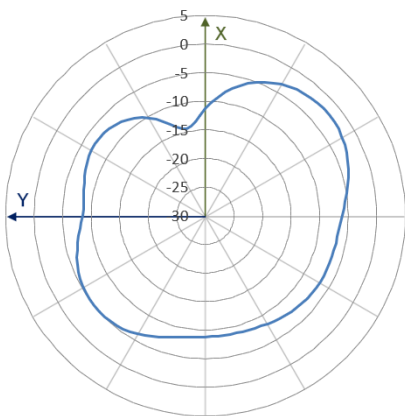

XZ Plane

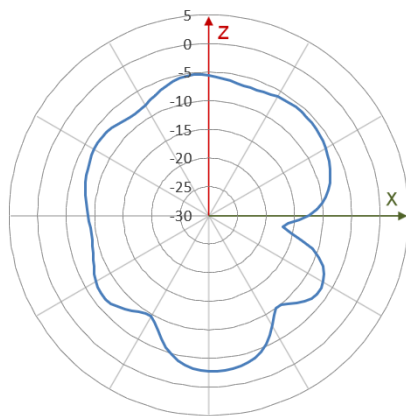

YZ Plane

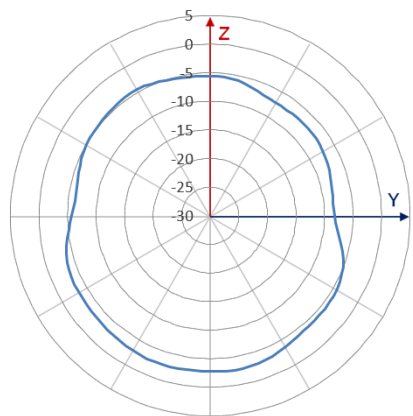

960MHz

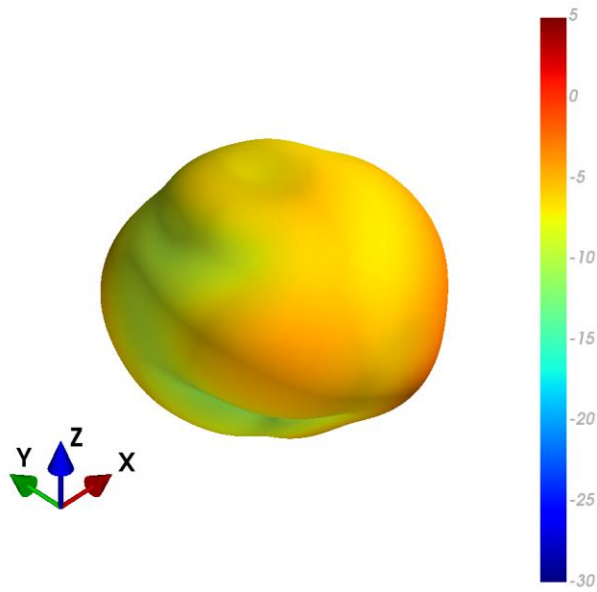

XY Plane

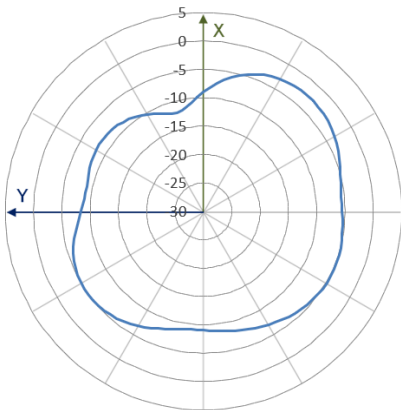

XZ Plane

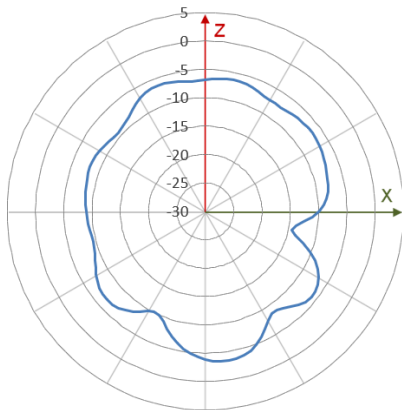

YZ Plane

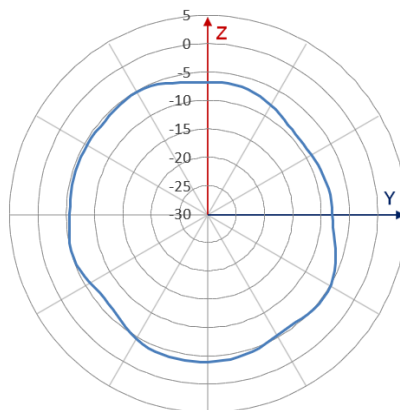

1575MHz

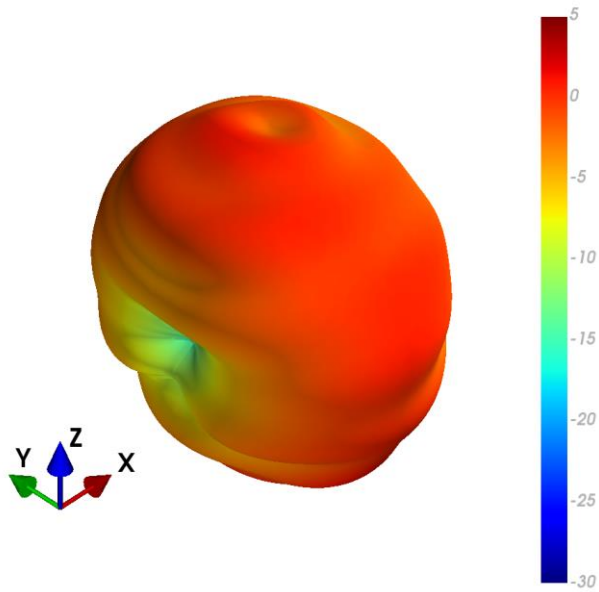

XY Plane

XZ Plane

YZ Plane

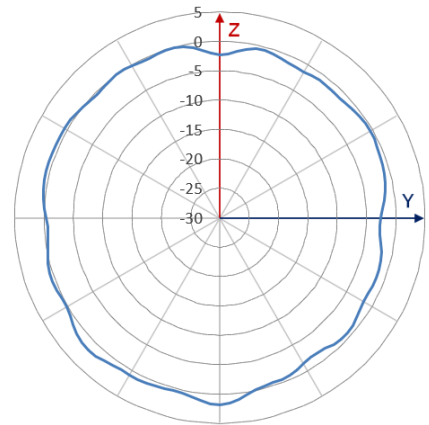
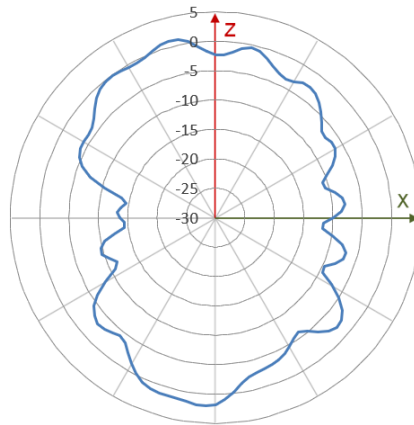
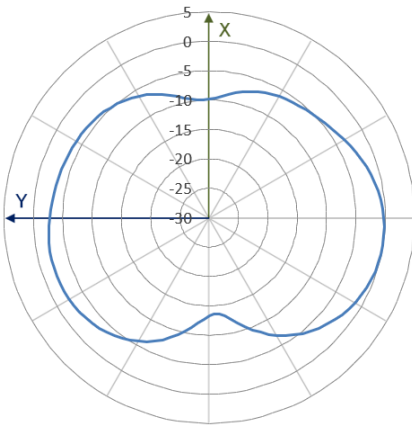

1700MHz

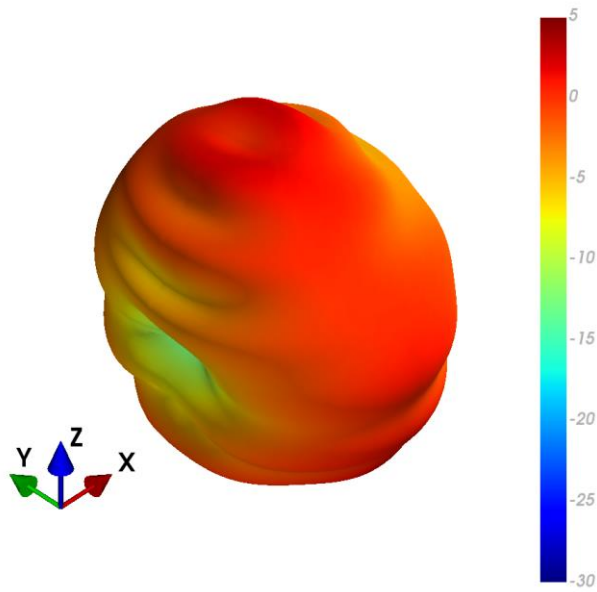

XY Plane

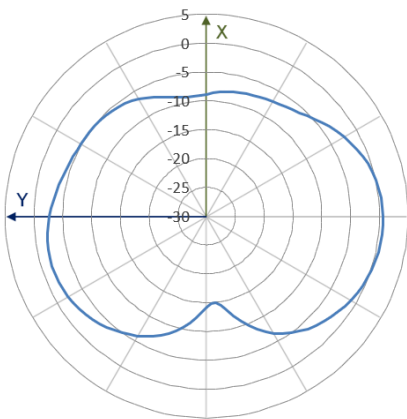

XZ Plane

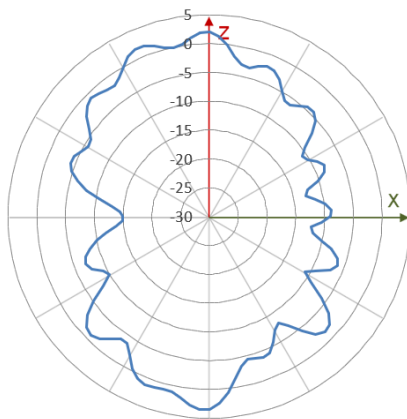

YZ Plane

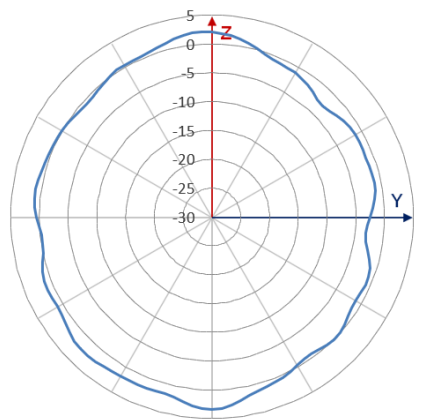

1880MHz

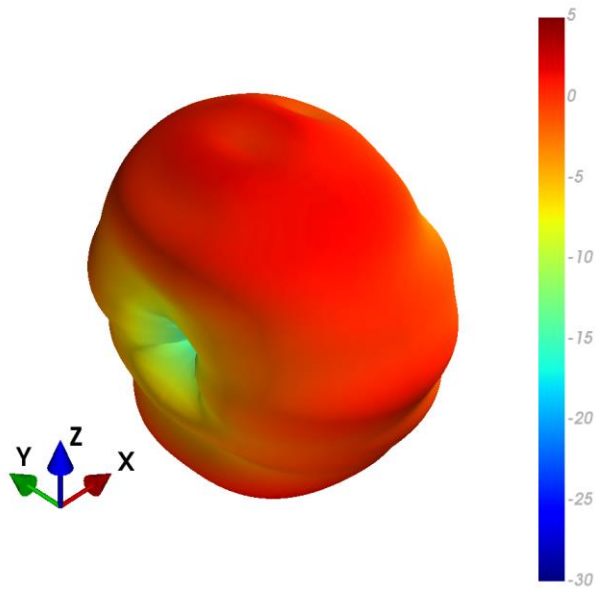

XY Plane

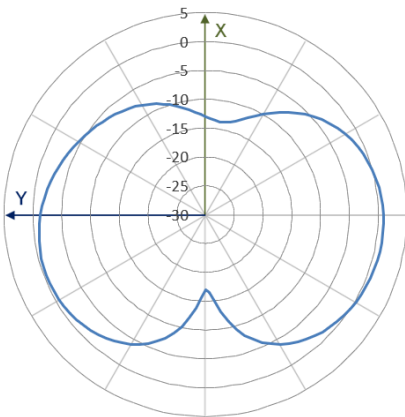

XZ Plane

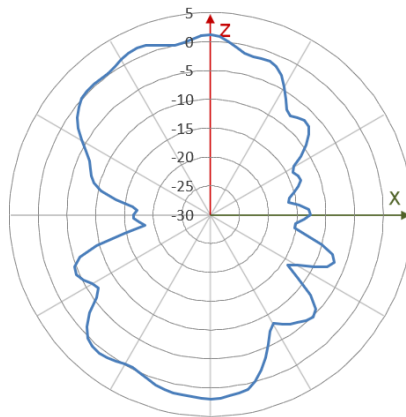

YZ Plane

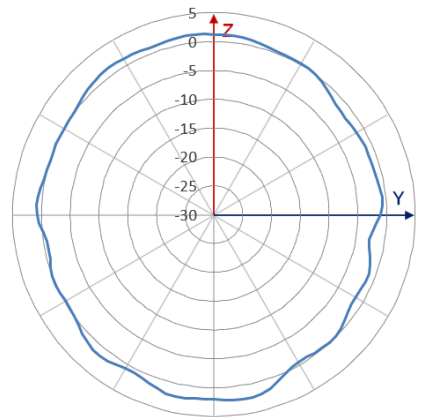

2170MHz

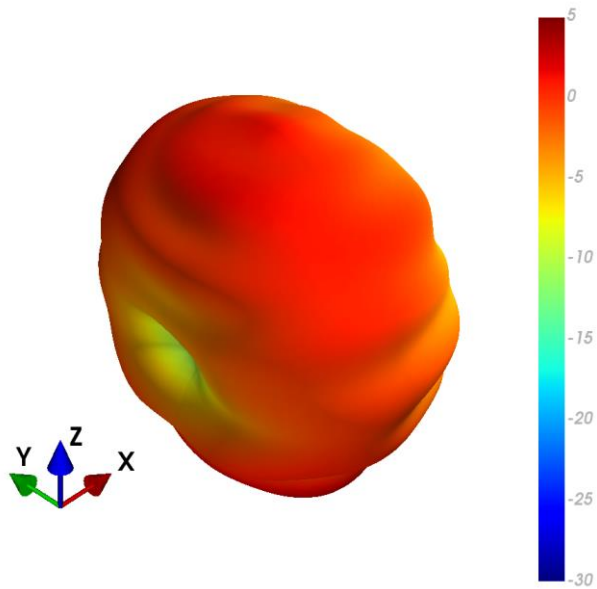

XY Plane

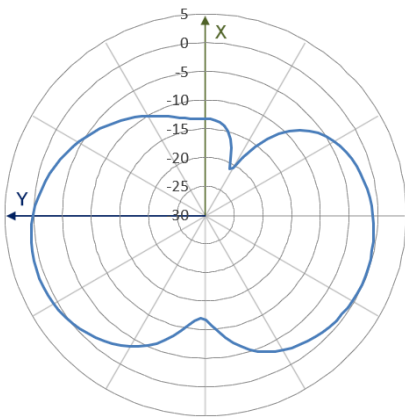

XZ Plane

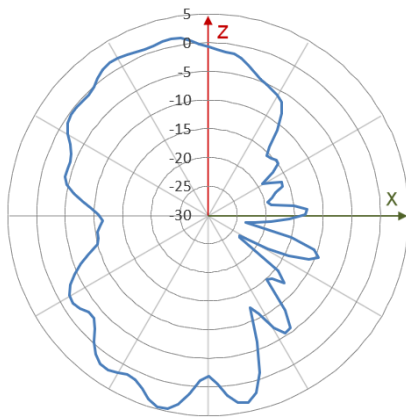

YZ Plane

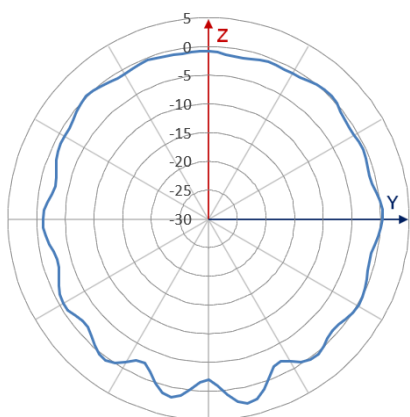

2500MHz

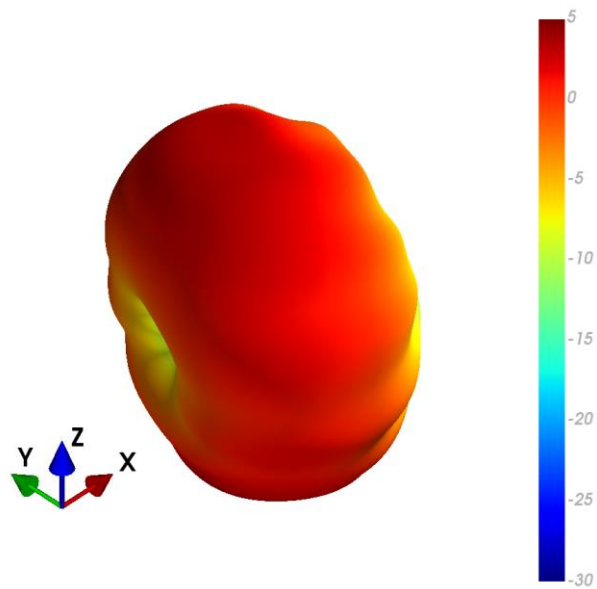

XY Plane

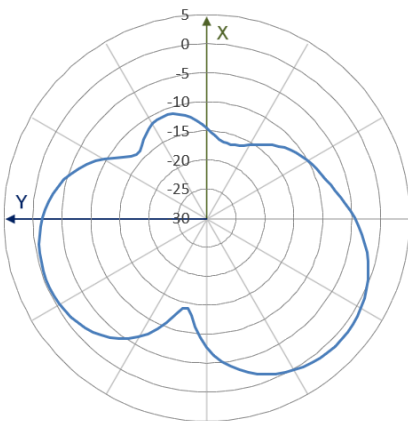

XZ Plane

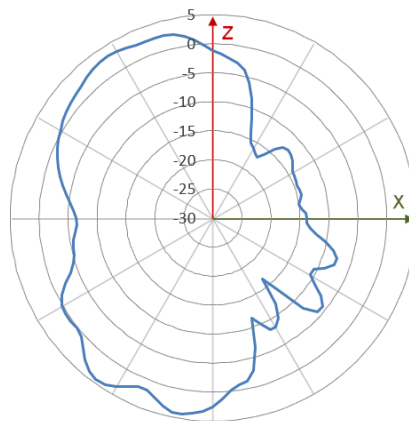

YZ Plane

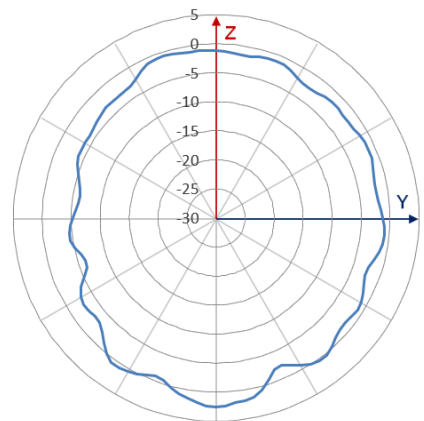

2700MHz

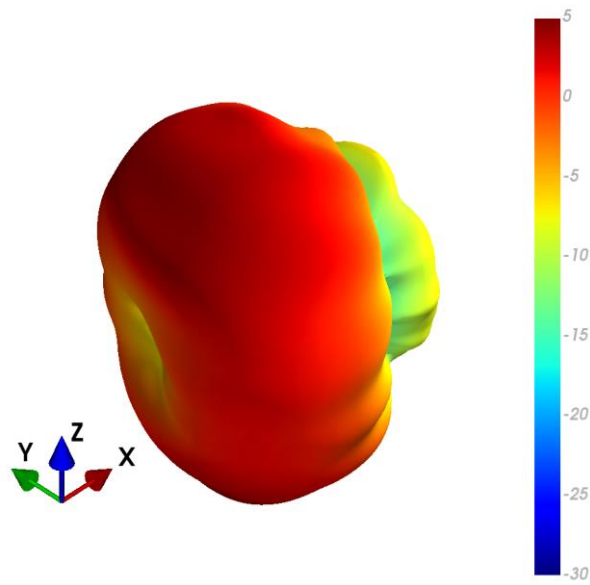

XY Plane

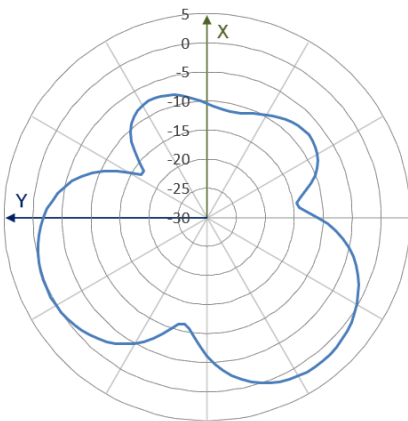

XZ Plane

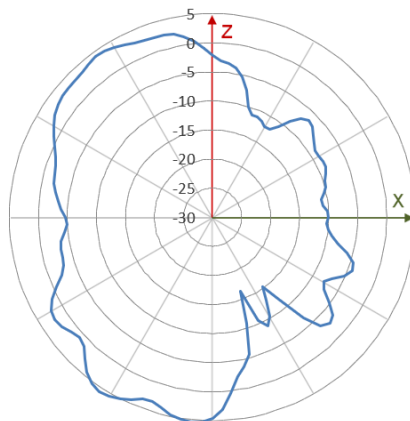

YZ Plane

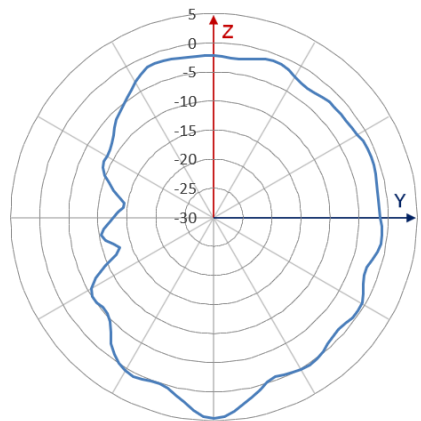

3500MHz

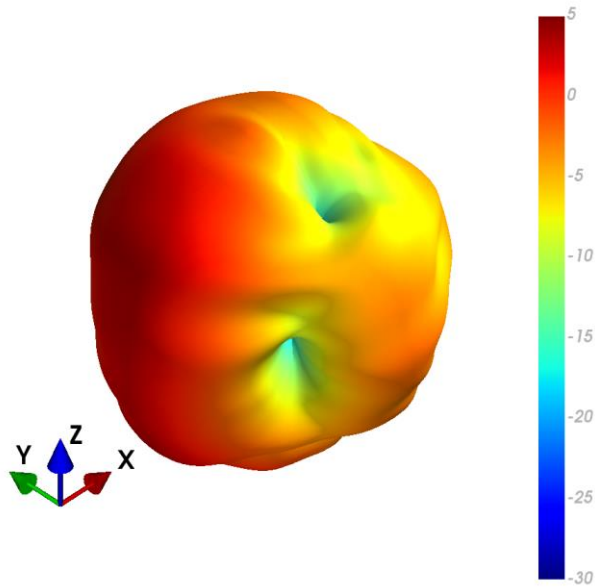

XY Plane

XZ Plane

YZ Plane

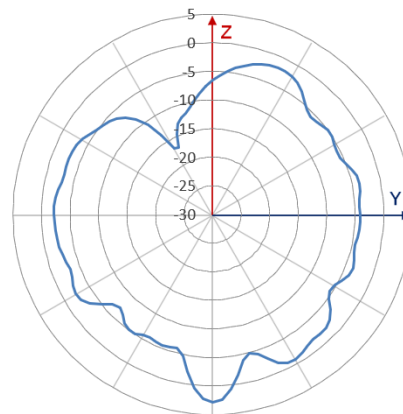
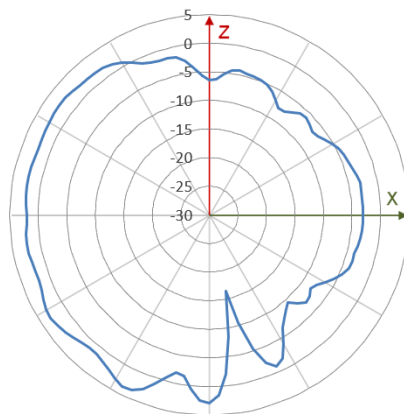
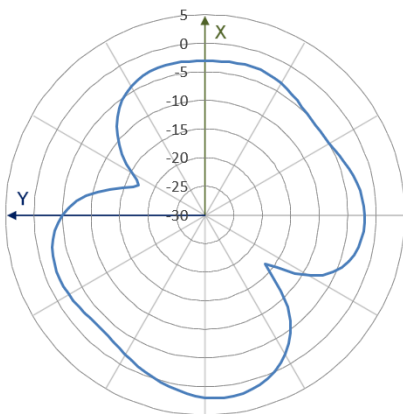

4500MHz

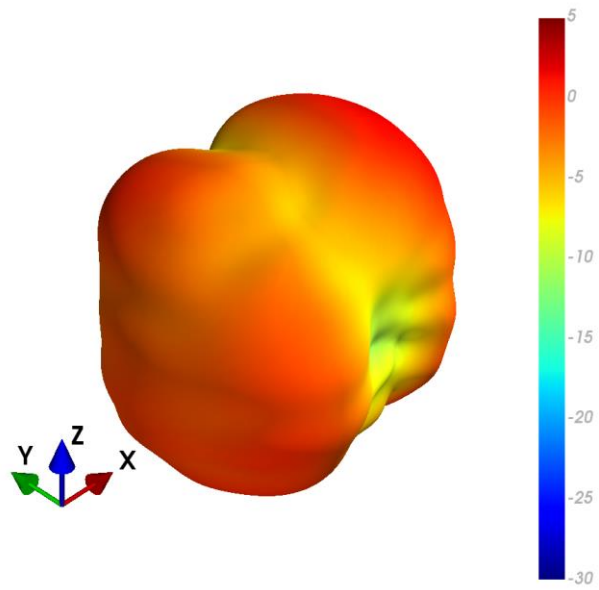

XY Plane

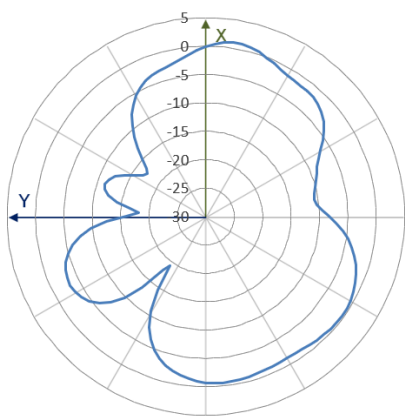

XZ Plane

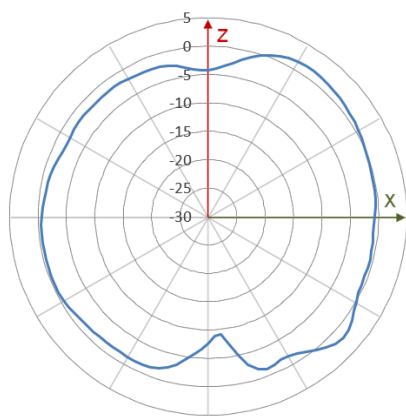

YZ Plane

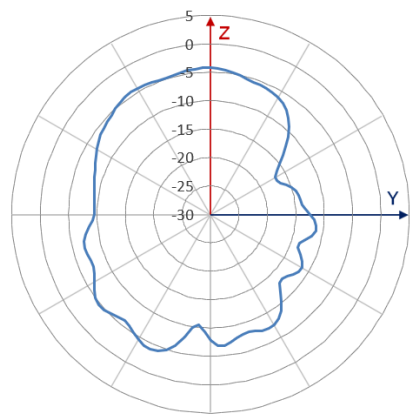

5500MHz

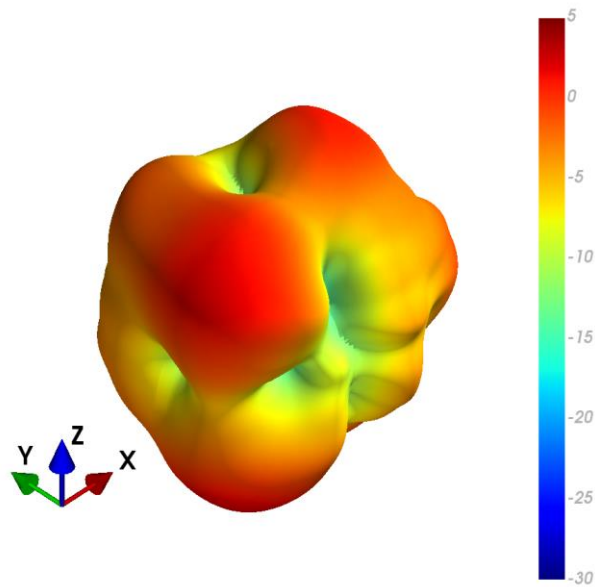

XY Plane

XZ Plane

YZ Plane

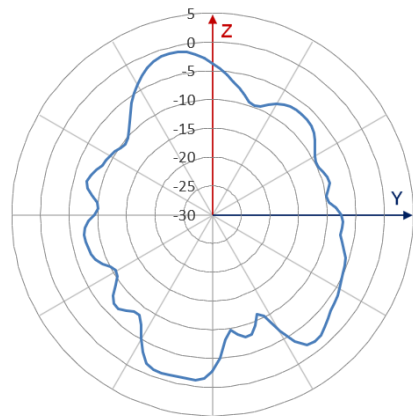
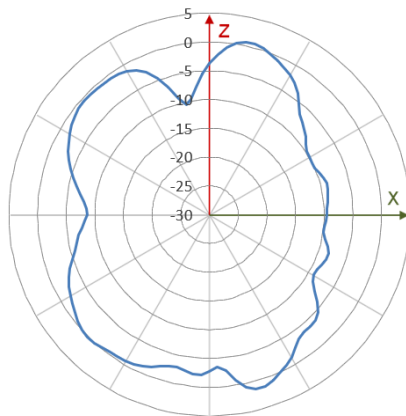
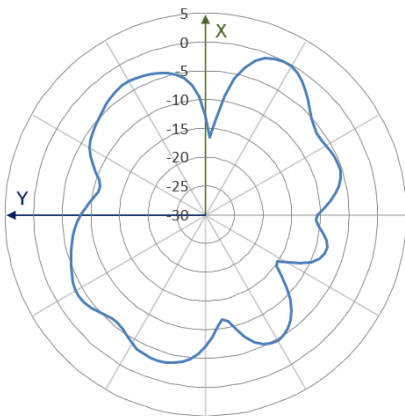

6. Mechanical Drawing (Units: mm)

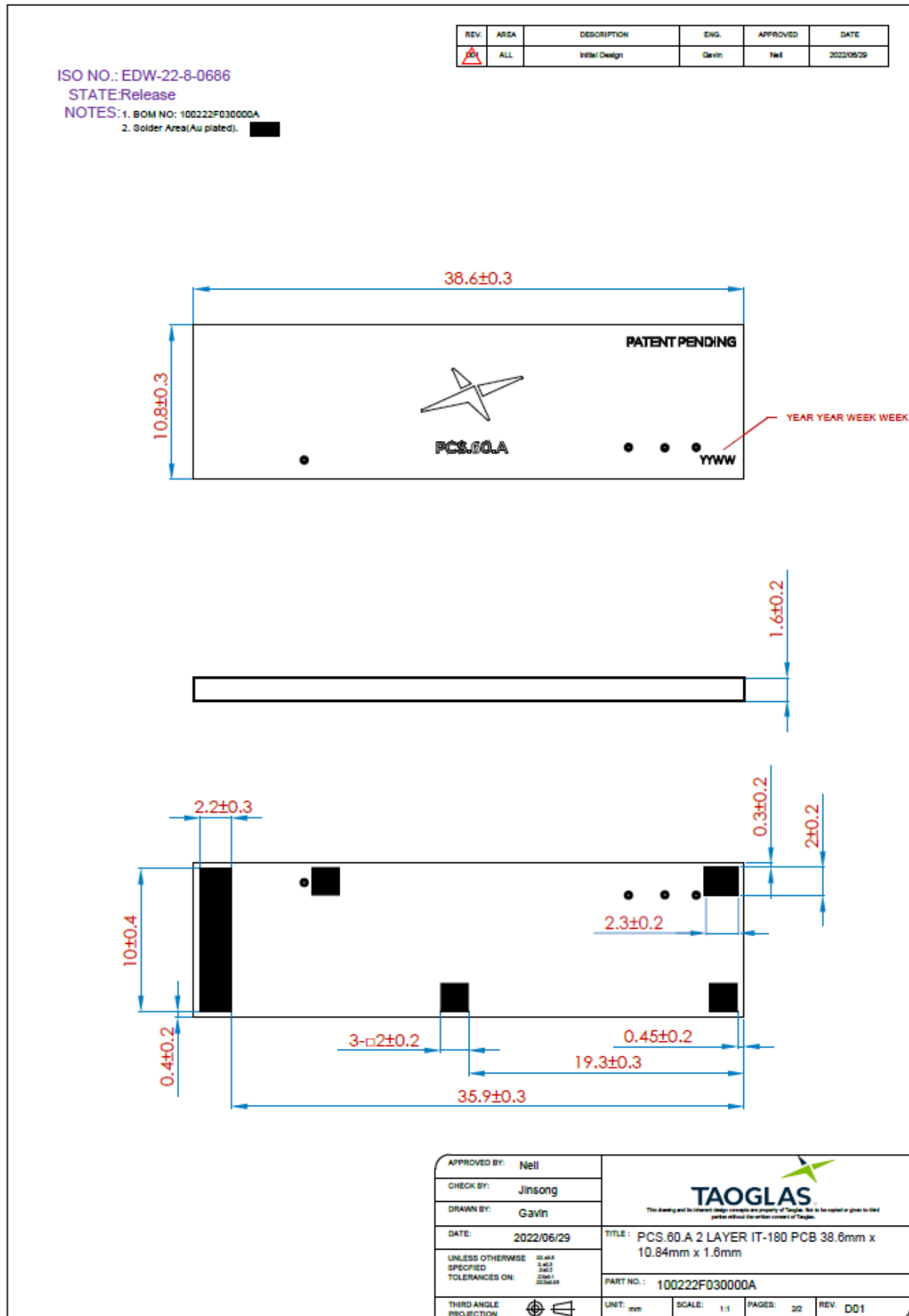

7. Antenna Integration Guide



7.1 Schematic Symbol and Pin Definition

The circuit symbol for the antenna is shown below. The antenna has 5 pins with only two pins (Pin 1 and Pin 2) as functional. Pins 3, 4 and 5 are not connected.

Pin	Description
1	RF Feed
2	Tuning
3, 4, 5	Not Connected

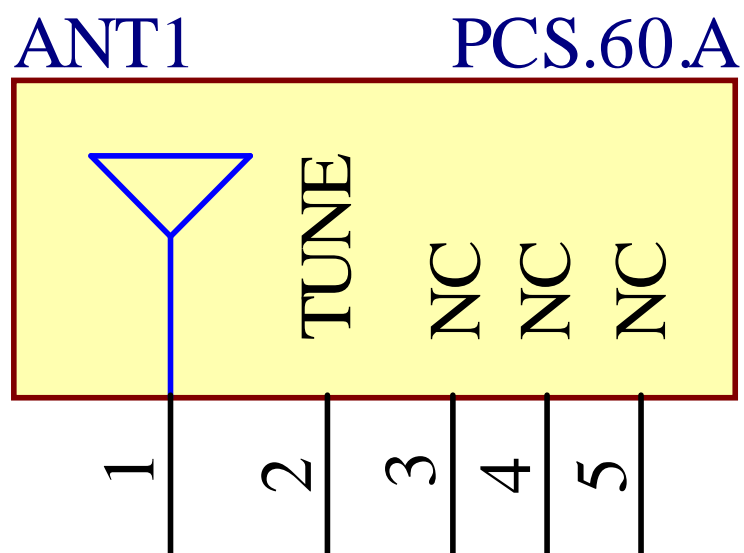

Please note you can download the design files, **3D model** and **2D drawings** from the website here:

<https://www.taoglas.com/product/universe-pcs-60-designed-for-iot-devices/>

7.2 Antenna Integration

Whatever the size of the PCB, the antenna should ideally be placed on the PCB's shortest side, to take advantage of the ground plane. Optimized matching components can be placed as shown.



With Solder Mask



Without Solder Mask

7.3 PCB Layout

The footprint and clearance on the PCB must meet the antenna specification. An example of the PCB layout shows the antenna footprint with clearance.



Topside

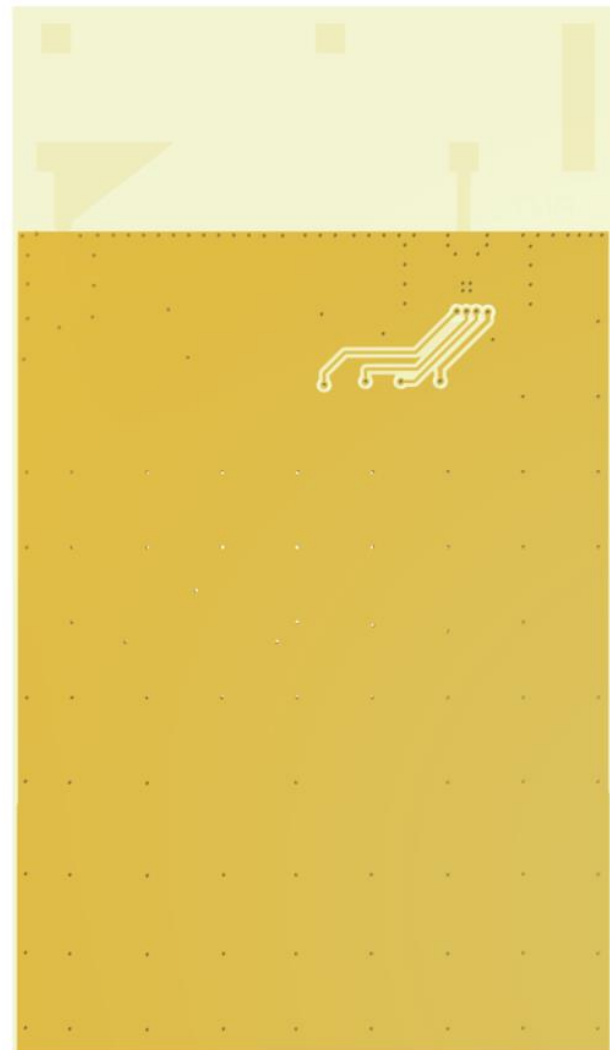

Bottom side

7.4 PCB Clearance

Below shows the antenna footprint and clearance through ALL layers on the PCB. Only the antenna pads and connections to feed and GND are present within this clearance area (marked RED). The clearance area extends to 4.4mm from the antenna mechanical pads to the ground area. This clearance area includes the bottom side and ALL internal layers on the PCB.

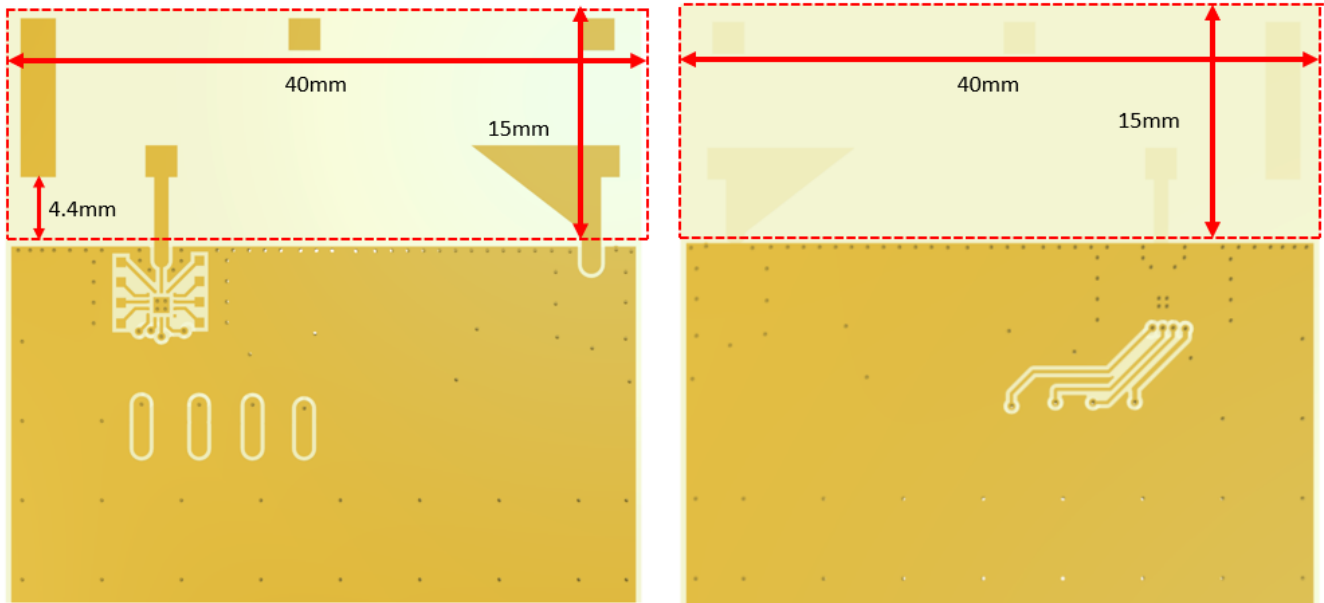

Topside

Bottom side

7.6 Evaluation Board



Topside



Bottom side

7.7 Evaluation Ground plane Length

Ground Plane Length
55mm



Topside

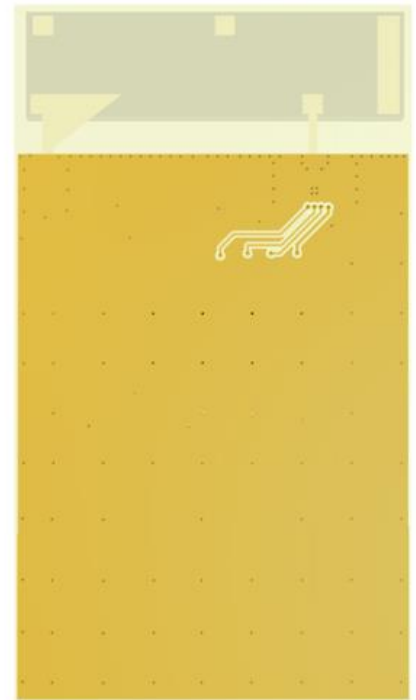

Bottom side

8. Packaging

1000pc PCS.60.A Per Reel
 Dimensions – Ø330*60mm
 Weight – 3230g

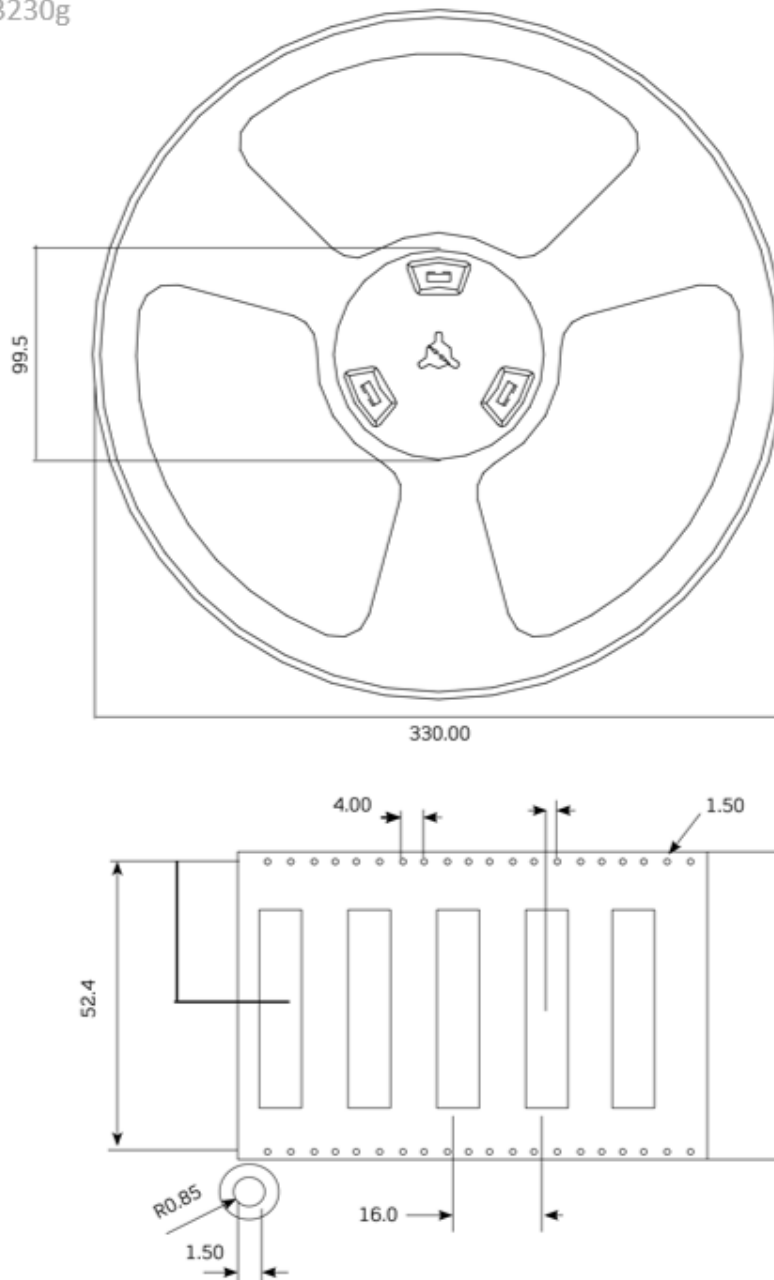

1000pc PCS.60.A Per Reel
 Dimensions – Ø330*60mm
 Weight – 3230g

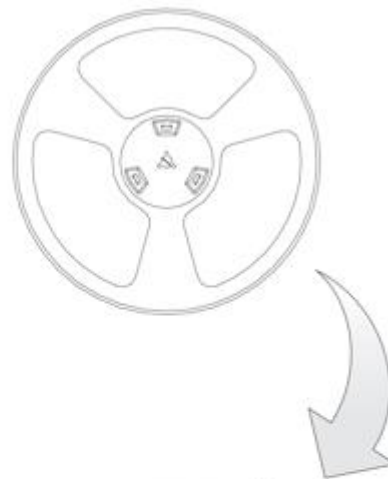

1000pc PCS.60.A / 1 Per Reel in small box
 Dimensions – Ø335*335*85mm
 Weight – 3.5Kg

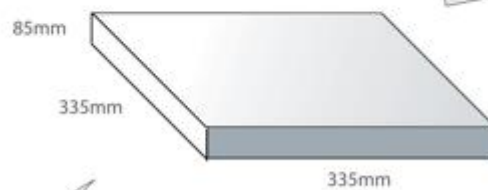

3 Reels, 3000pcs in one carton
 Carton Dimensions – 370*360*275mm
 Weight – 11.3Kg

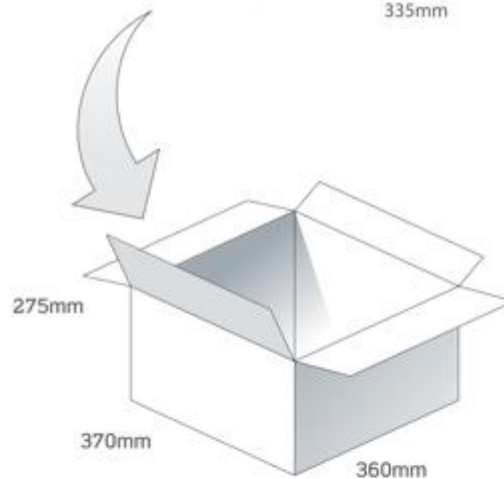

Pallet Dimensions 1200*1000*1320mm
 24 Carton per pallet
 6Cartons per layer
 4 Layers

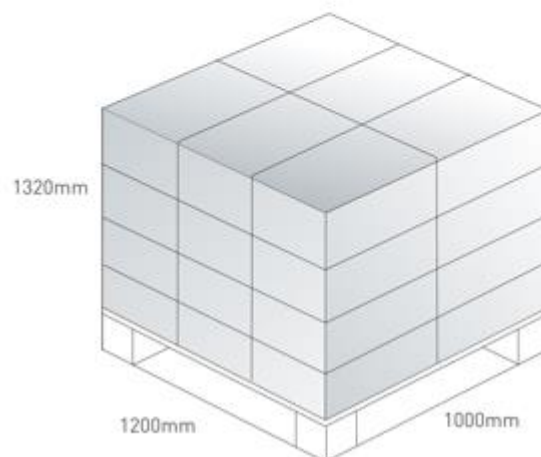

9. Application Note

9.1 Radio Module Selection for PCS.60.A

PCS.60.A is a smart antenna solution that works together with a radio module creating a whole RF system. When using the PCS.60.A antenna as part of a design, a suitable radio module will need to be selected that can control a tuneable antenna solution. Typically, there are two types of radio modules that operate with a tuneable antenna solution:

- Radio module with GPIO interface
- Radio module with MIPI interface

Depending on the radio module selected the RF switch should also have the same interface. As an example, a radio module with a GPIO interface requires an RF switch with a GPIO interface.

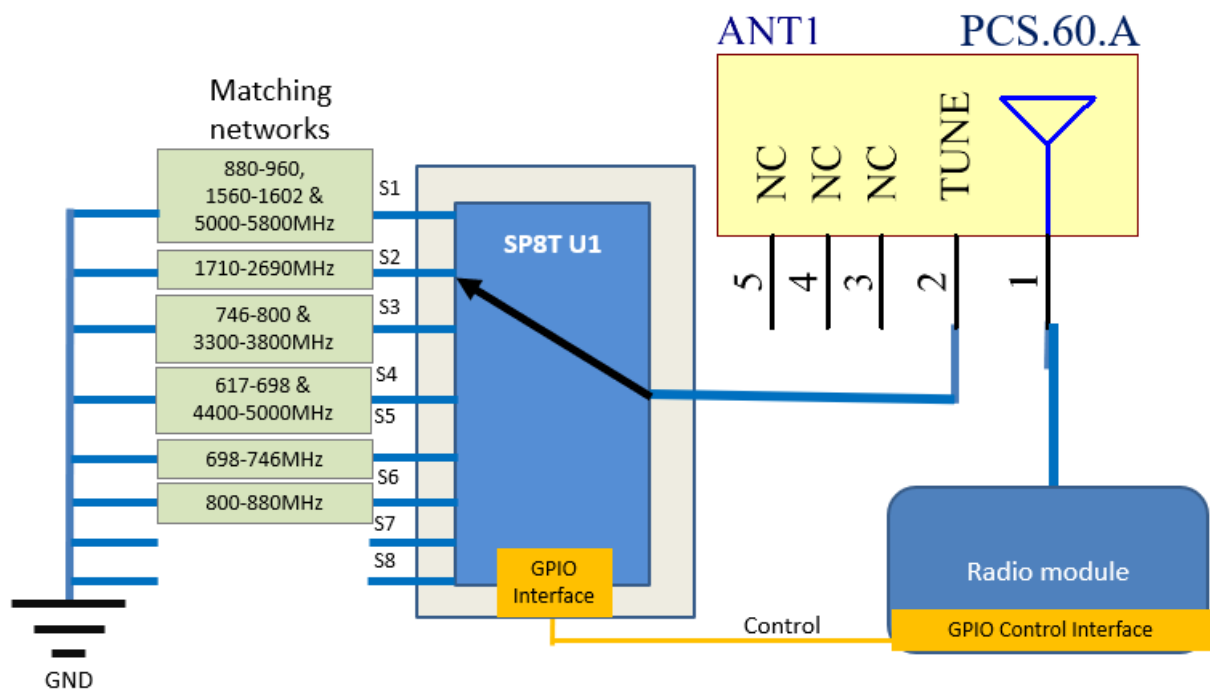

9.2 PCS.60.A Integration Service

Taoglas offer integration services for this device please contact customer services or local sales for more support.

A mapping table will be generated during the integration service. The mapping table links the matching circuits with the frequency bands and RF states (one example is shown below). The mapping table will be programmed within the interface of the radio module. When the radio module selects the frequency band, it uses the RF switch to select the best matching circuits for that frequency corresponding to the mapping table.

GPIO_1=V1	GPIO_2=V2	GPIO_3=V3	SP8T State	Matching Components	Frequency Coverage
0	0	0	S1:M1-ANT	OR	880-960, 1560-1602 & 5000-5800MHz
0	0	1	S2:M2-ANT	10pF, GJM1555C1H100FB01D	1710-2690MHz
0	1	0	S3:M3-ANT	7.5nH, L-07C7N5JV6S	746-800 & 3300-3800MHz
0	1	1	S4:M4-ANT	12nH, L-07C12NJV6T	617-698 & 4400-5000MHz
1	0	0	S5:M5-ANT	8.2nH, L-07C8N2JV6S	698-746MHz
1	0	1	S6:M6-ANT	4.7nH L-07C4N7JV6S	800-880MHz
1	1	0	S7:M7-ANT	N/F	Reserved for future application
1	1	1	S8:M8-ANT	N/F	Reserved for future application

PCS.60.A covers both LTE and GNSS. An SPDT can be used to choose between LTE and GNSS if needed.

9.3 Antenna Integration PCB Template for PCS.60.A

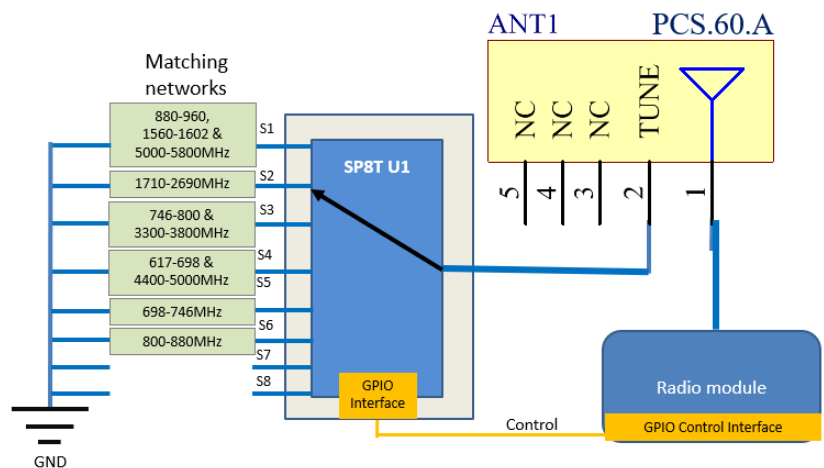
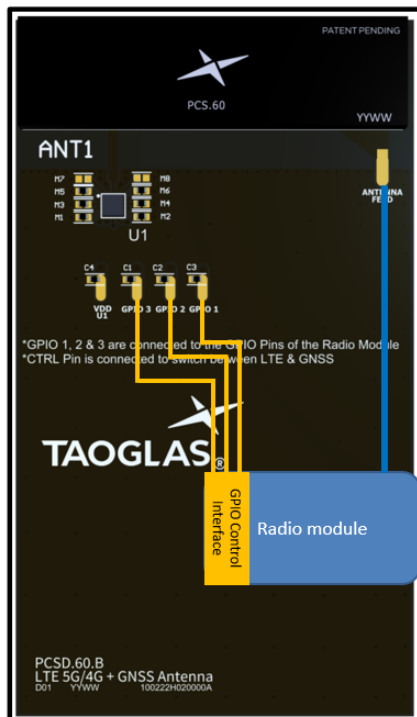

Taoglas has pre designed an antenna integration PCB template to help with the PCS.60.A integration into our customers PCB download from product page here [_____](#).

In the PCB template, The Antenna, foot print, RF switches are present. Customers just need to bring their design to the same PCB, and link up the VDD, GPIOs, RF port to the radio module and design the surrounding circuits. Customers are free to change the shape and dimensions of the ground plane (excluding the antenna clearance area) according to their application. For more information/support, please contact Taoglas customer services or local sales.

10. Solder Reflow Recommendations

The PCS.60.A can be assembled by following the recommended soldering temperatures are as follows:

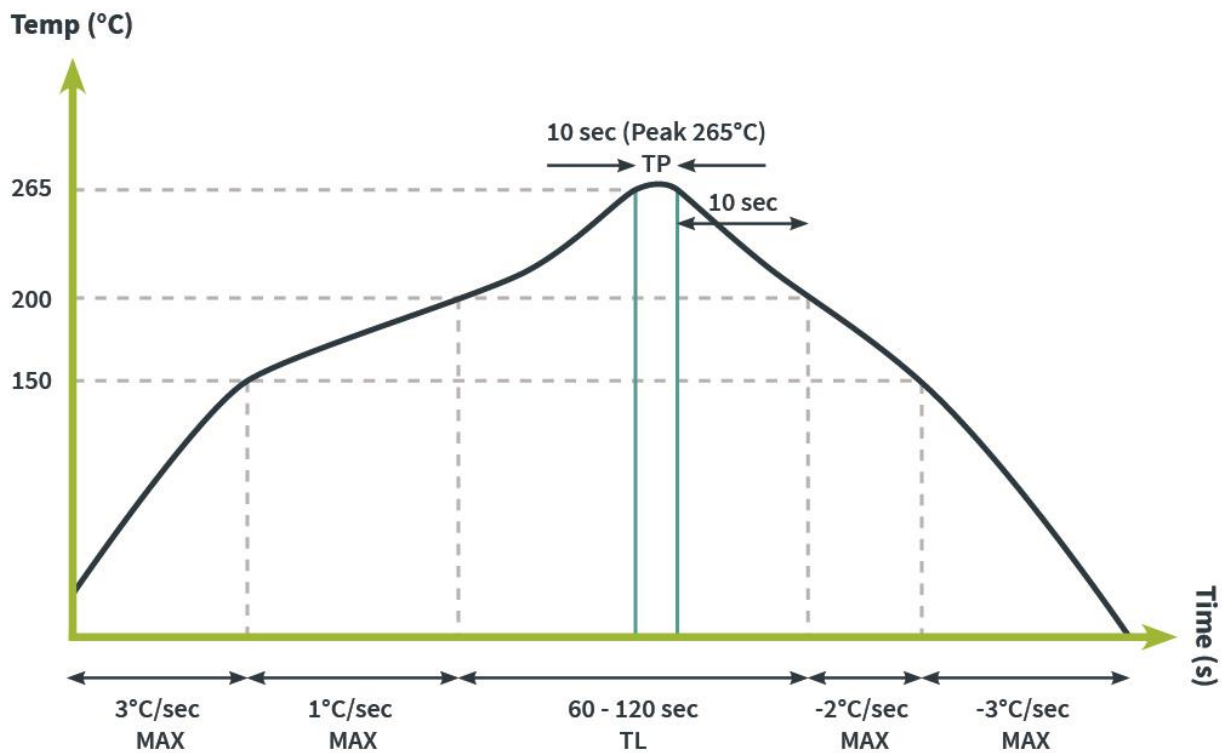

*Temperatures listed within a tolerance of +/- 10° C

The PCS.60.A is not limited to the number of passes through the reflow process. Smaller components are typically mounted on the first pass, however, we do advise mounting the PCS.60.A when placing larger components on the board during subsequent reflows.

Changelog for the datasheet

SPE-22-8-140 – PCS.60.A

Revision: A (First Release)	
Date:	2022-08-24
Changes:	First Release
Changes Made by:	Gary West

Previous Revisions



www.taoglas.com