

Description

The 9FGV1002C / 9FGV1006C are members of the Renesas' PhiClock™ programmable clock generator family. These devices are optimized for low phase noise spread-spectrum applications such as PCIe Express. Four user-defined configurations may be selected via two hardware select pins or two I²C bits, allowing easy software selection of the desired configuration. Any one of the four OTP configurations may be specified as the default when operating in I²C mode. Four unique I²C addresses are available, allowing easy I²C access to multiple components.

Typical Applications

- High-performance Computing (HPC)
- Enterprise Storage including eSSDs
- 10G / 25G / 100G Ethernet
- Fiber Optic Modules
- NVLink

PCIe Clocking Architectures

- Common Clocked (CC)
- Independent Reference (IR) without spread spectrum (SRnS)
- Independent Reference (IR) with spread spectrum (SRIS)

Output Features

- 2 or 4 programmable output pairs plus 2 LVCMOS REF outputs
- 1MHz–325MHz LVDS or LP-HCSL outputs
- 1MHz-200MHz LVCMOS outputs

Features

- 1.8V to 3.3V power supplies
- Individual 1.8V, 2.5V or 3.3V V_{DDO} for each output pair
- Supports HCSL, LVDS and LVCMOS I/O standards
- HCSL utilizes Renesas' LP-HCSL technology for improved performance, lower power and higher integration:
 - Programmable output impedance of 85Ω or 100Ω
- Supports LVPECL and CML logic with easy AC coupling – see application note [AN-891](#) for alternate terminations
- On-board OTP supports up to 4 complete configurations
 - 1 integer, fractional or spread spectrum output frequency per configuration
- Configuration selected via strapping pins or I²C
- Internal crystal load capacitors
- < 125mW (9FGV1002C – 1.8V with 100MHz LP-HCSL outputs)
- < 100mW (9FGV1006C – 1.8V with 100MHz LP-HCSL outputs)
- 4 programmable I²C addresses: D0, D2, D4, D6
- Easily configured with Renesas [Timing Commander™](#) software or Web Configuration tool
- 4 × 4 mm 24-VFQFPN with integrated crystal option
- 3 × 3 mm 16-LGA with integrated crystal option
- Programmable spread spectrum modulation frequency and amount

Key Specifications

- 276fs RMS 12kHz–20MHz typical phase jitter at 156.25MHz
- PCIe Gen6 jitter (CC) < 50fs RMS

9FGV1002C / 9FGV1006C Block Diagram

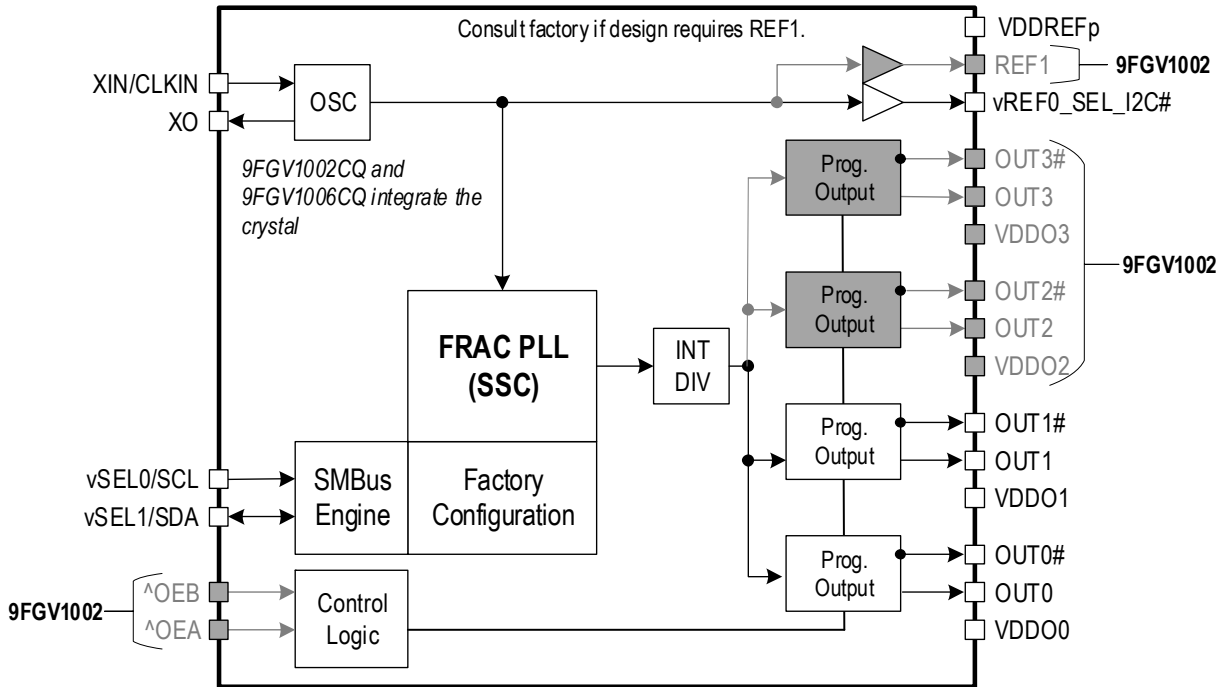

Table 1. OE Mapping

OE[B:A]	OUT0	OUT1	OUT2	OUT3	REF0	REF1
00	Running	Stopped	Stopped	Stopped	Running	Running
01	Running	Running	Stopped	Stopped	Running	Running
10	Running	Running	Running	Stopped	Running	Running
11	Running	Running	Running	Running	Running	Running

Contents

Description	1
Typical Applications	1
PCIe Clocking Architectures	1
Output Features	1
Features	1
Key Specifications	1
9FGV1002C / 9FGV1006C Block Diagram	2
Pin Assignments	4
9FGV1002C Pin Descriptions	5
9FGV1006C Pin Descriptions	6
Phase Noise Plots	7
Absolute Maximum Ratings	9
Thermal Characteristics	9
Recommended Operating Conditions	10
Electrical Characteristics	11
I2C Bus Characteristics	20
Test Loads	21
Crystal Characteristics	23
Package Outline Drawings	23
Marking Diagrams	23
Standard Configurations	24
Ordering Information	25
Revision History	25

Pin Assignments

Figure 1. Pin Assignments for 9FGV1002C 4 x 4 mm 24-VFQFPN and 24-LGA Packages – Top View

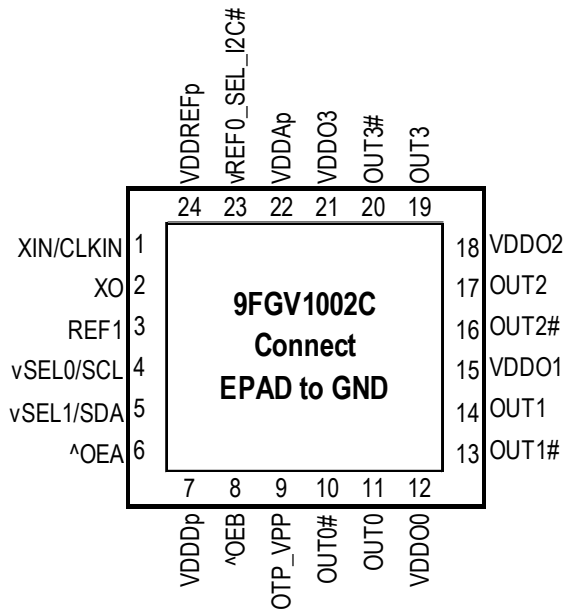

4 x 4 mm 24-QFN, 0.5mm pitch

^ prefix indicates internal pull-up
 v prefix indicates internal pull-down resistor
 Note: The order of OUT3 is reversed from OUT[0:2]

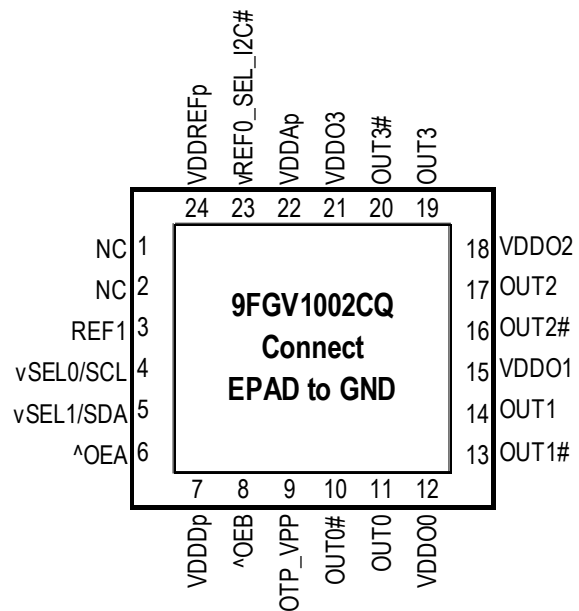

4 x 4 mm 24-LGA, 0.5mm pitch

^ prefix indicates internal pull-up resistor
 v prefix indicates internal pull-down resistor
 Note: The order of OUT3 is reversed from OUT[0:2]

Figure 2. Pin Assignments for 9FGV1006C 3 x 3 mm 16-LGA Package – Top View

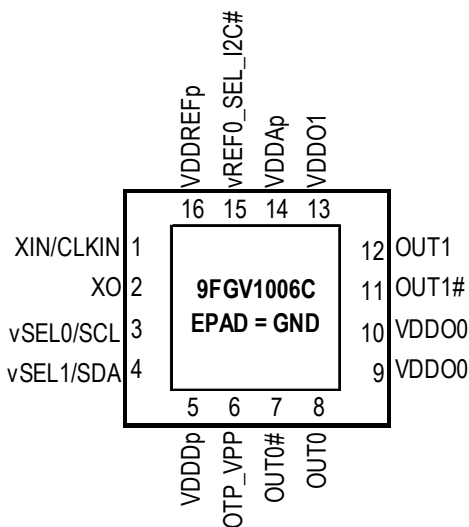

16-LGA 3 x 3 mm, 0.5mm pitch

^ prefix indicates internal pull-up resistor
 v prefix indicates internal pull-down resistor

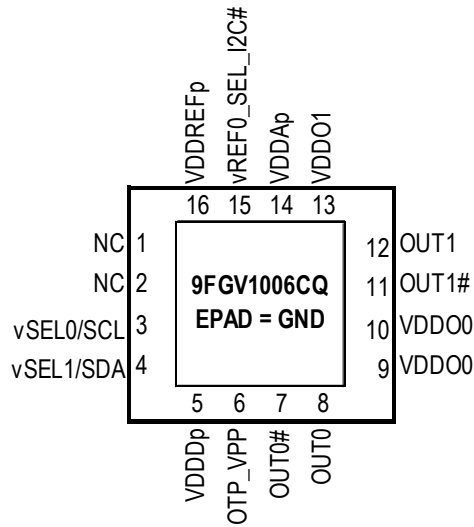

16-LGA 3 x 3 mm, 0.5mm pitch

^ prefix indicates internal pull-up resistor
 v prefix indicates internal pull-down resistor

9FGV1002C Pin Descriptions

Note: Unused outputs can be programmed off and left floating. Output supplies V_{DDREF} and V_{DDO2} have to be connected. If OUT0 is used, V_{DDO1} must also be connected.

Table 2. 9FGV1002C Pin Descriptions

Number	Name	Type	Description
1 ^[a]	XIN/CLKIN	Input	Crystal input or reference clock input.
2 ^[a]	XO	Output	Crystal output.
3	REF1	Output	LVC MOS reference output.
4	vSEL0/SCL	Input	Select pin for internal frequency configurations/I ² C clock pin. Function is determined by state of SEL_I2C# upon power-up. This pin has an internal pull-down.
5	vSEL1/SDA	I/O	Select pin for internal frequency configurations/I ² C data pin. Function is determined by state of SEL_I2C# upon power-up. This pin has an internal pull-down.
6	^OE A	Input	Active high input for enabling outputs. This pin has an internal pull-up resistor. 0 = disable outputs, 1 = enable outputs.
7	VDDDp	Power	Digital power. Connect to 1.8V, 2.5V or 3.3V.
8	^OE B	Input	Active high input for enabling outputs. This pin has an internal pull-up resistor. 0 = disable outputs, 1 = enable outputs.
9	OTP_VPP	Power	Voltage for programming OTP. During normal operation, this pin should be connected to the same power rail as V_{DD} .
10	OUT0#	Output	Complementary output clock 0.
11	OUT0	Output	Output clock 0.
12	VDDO0	Power	Power supply for output 0.
13	OUT1#	Output	Complementary output clock 1.
14	OUT1	Output	Output clock 1.
15	VDDO1	Power	Power supply for output 1.
16	OUT2#	Output	Complementary output clock 2.
17	OUT2	Output	Output clock 2.
18	VDDO2	Power	Power supply for output 2.
19	OUT3	Output	Output clock 3.
20	OUT3#	Output	Complementary output clock 3.
21	VDDO3	Power	Power supply for output 3.
22	VDDAp	Power	Analog power. Connect to same voltage as VDDDp, with proper filtering.
23	vREF0_SEL_I2C#	Latched I/O	Latched input/LVC MOS output. At power-up, the state of this pin is latched to select the state of the I ² C pins. After power-up, the pin acts as an LVC MOS reference output. This pin has an internal pull-down. 1 = SEL0/SEL1. 0 = SCL/SDA.
24	VDDREFp	Power	Power supply for REF outputs and the internal XO. Nominal voltages are 1.8V, 2.5V or 3.3V.
25	EPAD	GND	Connect to ground.

[a] These pins are 'No Connect' on 9FGV1002Q integrated quartz versions and should have no stubs.

9FGV1006C Pin Descriptions

Note: Unused outputs can be programmed off and left floating. Output supplies V_{DDREF} and V_{DDO1} have to be connected. This means that if only one output is to be used, it must be OUT1. If OUT0 is used, both pins 9 and 10 must be connected. They may share the same power filter.

Table 3. 9FGV1006C Pin Descriptions

Number	Name	Type	Description
1 ^[a]	XIN/CLKIN	Input	Crystal input or reference clock input.
2 ^[a]	XO	Output	Crystal output.
3	vSEL0/SCL	Input	Select pin for internal frequency configurations/I ² C Clock pin. Function is determined by state of SEL_I2C# upon power-up. This pin has an internal pull-down.
4	vSEL1/SDA	I/O	Select pin for internal frequency configurations/I ² C Data pin. Function is determined by state of SEL_I2C# upon power-up. This pin has an internal pull-down.
5	VDDDp	Power	Digital power. Connect to 1.8V, 2.5V or 3.3V.
6	OTP_VPP	Power	Voltage for programming OTP. During normal operation, this pin should be connected to the same power rail as V_{DD} .
7	OUT0#	Output	Complementary output clock 0.
8	OUT0	Output	Output clock 0.
9	VDDO0	Power	Power supply for output 0.
10	VDDO0	Power	Power supply for output 0.
11	OUT1#	Output	Complementary output clock 1.
12	OUT1	Output	Output clock 1.
13	VDDO1	Power	Power supply for output 1.
14	VDDAp	Power	Analog power. Connect to same voltage as VDDDp, with proper filtering.
15	vREF0_SEL_I2C#	Latched I/O	Latched input/LVCMOS output. At power-up, the state of this pin is latched to select the state of the I ² C pins. After power-up, the pin acts as an LVCMOS reference output. This pin has an internal pull-down. 1 = SEL0/SEL1. 0 = SCL/SDA.
16	VDDREFp	Power	Power supply for REF outputs and the internal XO. Nominal voltages are 1.8V, 2.5V or 3.3V.
17	EPAD	GND	Connect to ground.

[a] These pins are 'No Connect' on 9FGV1006Q integrated quartz version and should have no stubs.

Phase Noise Plots

Figure 3. 9FGV1002C Phase Noise Plot¹, 3.3V, 25°C.

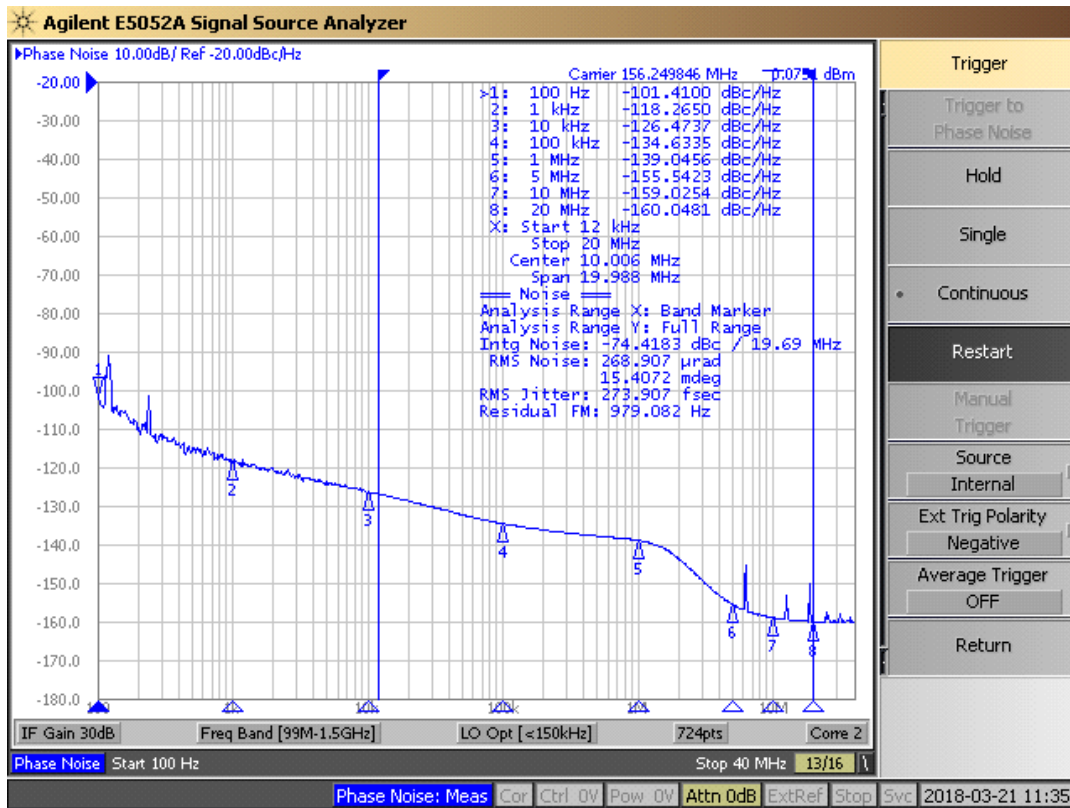

¹ See Test Frequencies for Jitter Measurements table for details.

Figure 4. 9FGV1006C Phase Noise Plot¹, 3.3V, 25°C.

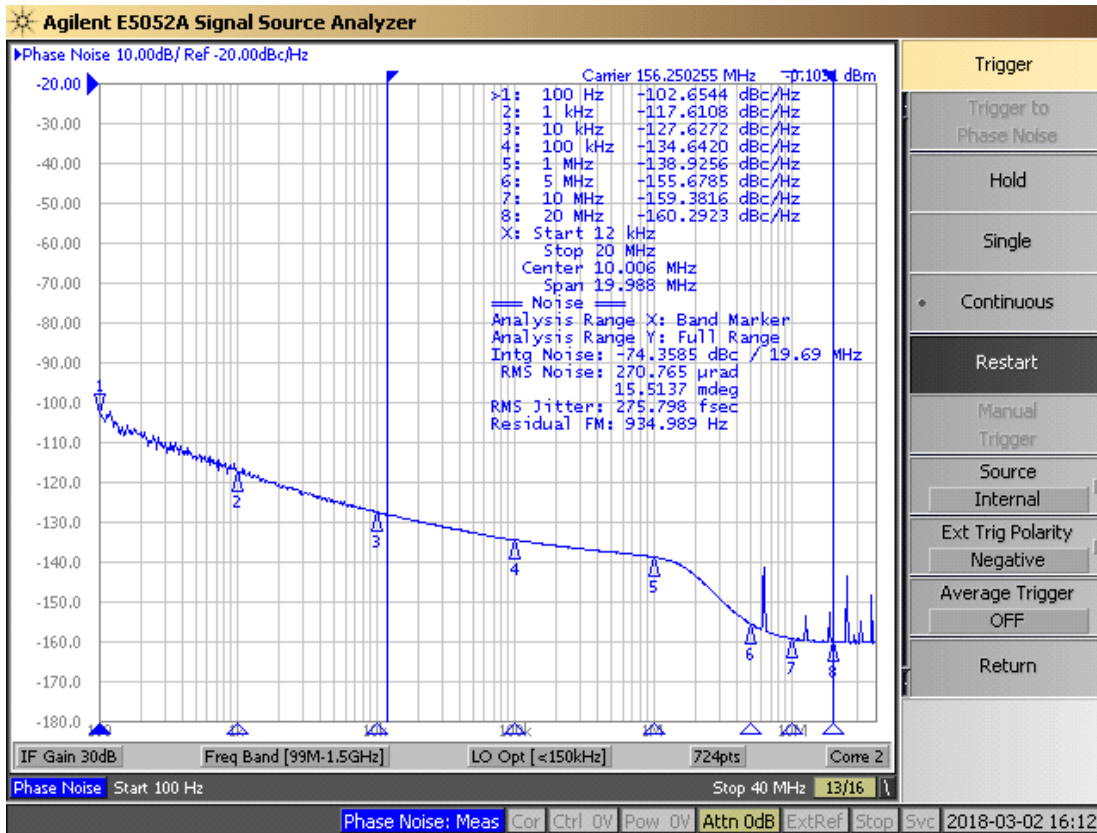

¹ See Test Frequencies for Jitter Measurements table for details.

Absolute Maximum Ratings

The absolute maximum ratings are stress ratings only. Stresses greater than those listed below can cause permanent damage to the device. Functional operation of the 9FGV1002C / 9FGV1006C at absolute maximum ratings is not implied. Exposure to absolute maximum rating conditions may affect device reliability.

Table 4. Absolute Maximum Ratings

Parameter	Rating
Supply Voltage, V_{DDA} , V_{DDD} , V_{DDO}	3.9V
Storage Temperature, T_{STG}	-65°C to 150°C
ESD Human Body Model	2000V
Junction Temperature	125°C
Inputs	
XIN/CLKIN	0V to 1.2V voltage swing
Other Inputs	-0.5V to V_{DDD}
Outputs	
Outputs, V_{DDO} (LVCMOS)	-0.5V to $V_{DDO} + 0.5V$
Outputs, IO (SDA)	10mA

Thermal Characteristics

Table 5. Thermal Characteristics for 24-pin Devices

Parameter	Symbol	Conditions	Package	Typical Values	Unit	Notes
Thermal Resistance (devices with external crystal)	θ_{JC}	Junction to case.	NBG24	52	°C/W	1
	θ_{Jb}	Junction to base.		2.3	°C/W	1
	θ_{JA0}	Junction to air, still air.		44	°C/W	1
	θ_{JA1}	Junction to air, 1 m/s air flow.		37	°C/W	1
	θ_{JA3}	Junction to air, 3 m/s air flow.		33	°C/W	1
	θ_{JA5}	Junction to air, 5 m/s air flow.		32	°C/W	1
Thermal Resistance Q-series (devices with internal crystal)	θ_{JC}	Junction to case.	LTG24	57.3	°C/W	1
	θ_{Jb}	Junction to base.		24.3	°C/W	1
	θ_{JA0}	Junction to air, still air.		79.8	°C/W	1
	θ_{JA1}	Junction to air, 1 m/s air flow.		73.9	°C/W	1
	θ_{JA3}	Junction to air, 3 m/s air flow.		69.9	°C/W	1
	θ_{JA5}	Junction to air, 5 m/s air flow.		67.3	°C/W	1

¹ EPAD soldered to board.

Table 6. Thermal Characteristics for 16-pin devices

Parameter	Symbol	Conditions	Package	Typical Values	Unit	Notes
Thermal Resistance (devices with external crystal)	θ_{JC}	Junction to case.	LTG16	66	°C/W	1
	θ_{Jb}	Junction to base.		5.1	°C/W	1
	θ_{JA0}	Junction to air, still air.		63	°C/W	1
	θ_{JA1}	Junction to air, 1 m/s air flow.		56	°C/W	1
	θ_{JA3}	Junction to air, 3 m/s air flow.		51	°C/W	1
	θ_{JA5}	Junction to air, 5 m/s air flow.		49	°C/W	1
Thermal Resistance Q-series (devices with internal crystal)	θ_{JC}	Junction to case.	LTG16	82.1	°C/W	1
	θ_{Jb}	Junction to base.		42.3	°C/W	1
	θ_{JA0}	Junction to air, still air.		93.6	°C/W	1
	θ_{JA1}	Junction to air, 1 m/s air flow.		87.1	°C/W	1
	θ_{JA3}	Junction to air, 3 m/s air flow.		83.3	°C/W	1

¹ EPAD soldered to board.

Recommended Operating Conditions

Table 7. Recommended Operating Conditions

Symbol	Parameter	Minimum	Typical	Maximum	Unit
V_{DDOx}	Power supply voltage for supporting 1.8V outputs.	1.71	1.8	1.89	V
	Power supply voltage for supporting 2.5V outputs.	2.375	2.5	2.625	V
	Power supply voltage for supporting 3.3V outputs.	3.135	3.3	3.465	V
V_{DDD}	Power supply voltage for core logic functions.	1.71	-	3.465	V
V_{DDA}	Analog power supply voltage. Use filtered analog power supply if available.	1.71	-	3.465	V
T_A	Operating temperature, ambient.	-40	-	85	°C
C_L	Maximum load capacitance (3.3V LVCMOS only).	-	-	15	pF
t_{PU}	Power-up time for all V_{DDs} to reach minimum specified voltage (power ramps must be monotonic).	0.05	-	5	ms

Electrical Characteristics

$V_{DDx} = 3.3V \pm 5\%$, $2.5V \pm 5\%$, $1.8V \pm 5\%$, $T_A = -40^\circ C$ to $+85^\circ C$ unless stated otherwise.

Table 8. Common Electrical Characteristics

Parameter	Symbol	Conditions	Minimum	Typical	Maximum	Unit	Notes
Input Frequency	f_{IN}	Crystal input frequency.	8	-	50	MHz	1
		CLKIN input frequency.	1	-	240	MHz	5
Output Frequency	f_{OUT}	Differential clock output (LVDS/LP-HCSL).	1	-	325	MHz	-
		Single-ended clock output (LVCMOS).	1	-	200	MHz	-
VCO Frequency	f_{VCO}	VCO operating frequency range.	2400	2500	2600	MHz	-
Loop Bandwidth	f_{BW}	Input frequency = 25MHz.	0.06	-	0.9	MHz	-
Input High Voltage	V_{IH}	SEL[1:0].	$0.7 \times V_{DDD}$	-	$V_{DDD} + 0.3$	V	-
Input Low Voltage	V_{IL}	SEL[1:0].	$GND - 0.3$	-	0.8	V	-
Input High Voltage	V_{IH}	REF/SEL_I2C#.	$0.65 \times V_{DDREF}$	-	$V_{DDREF} + 0.3$	V	-
Input Low Voltage	V_{IL}	REF/SEL_I2C#.	-0.3	-	0.4	V	-
Input High Voltage	V_{IH}	XIN/CLKIN.	0.8	-	1.2	V	-
Input Low Voltage	V_{IL}	XIN/CLKIN.	-0.3	-	0.4	V	-
Input Rise/Fall Time	T_R/T_F	OEA, OEB (when present)	-	-	10	ns	-
		SEL1/SDA, SEL0/SCL	-	-	300		-
Input Capacitance	C_{IN}	SEL[1:0].	-	3	7	pF	-
Internal Pull-up Resistor	R_{UP}		200	237	300	k Ω	-
Internal Pull-down Resistor	R_{DOWN}		200	237	300	k Ω	-
Programmable Capacitance at XIN and XO (XIN in parallel with XO)	C_L	XIN/CLKIN, XO.	0	-	8	pF	-
Input Duty Cycle	t2	CLKIN, measured at $V_{DDREF}/2$.	40	50	60	%	-
Output Duty Cycle	t3	LVCMOS, $f_{OUT} > 156.25MHz$.	40	50	60	%	-
		LVCMOS, $f_{OUT} \leq 156.25MHz$.	45	50	55	%	-
		LVDS, LP-HCSL outputs.	45	50.2	55	%	-
Clock Jitter	t6	Cycle-to-cycle jitter (Peak-to-Peak), See Test Frequencies for Jitter Measurements for configurations.	-	24	-	ps	4
		Reference clock RMS phase jitter (12kHz to 20MHz integration range). See Test Frequencies for Jitter Measurements for configurations.	-	245	-	fs rms	4
		OUTx RMS phase jitter(12kHz to 20MHz integration range) differential output. See Test Frequencies for Jitter Measurements for configurations.	-	276	-	fs rms	4

Table 8. Common Electrical Characteristics (Cont.)

Parameter	Symbol	Conditions	Minimum	Typical	Maximum	Unit	Notes
Output Skew	t7	All outputs using the same driver format same V _{DDO} voltage. (9FGV1006C).	-	38	60	ps	-
		All outputs using the same driver format and same V _{DDO} voltage. (9FGV1002C).	-	62	100		-
Lock Time	t8a	PLL outputs valid from V _{DDs} reaching 1.5V.	-	5	10	ms	2,3
	t8b	REF outputs valid from V _{DDs} reaching 1.5V.	-	5	11	ms	2,3

¹ Practical lower frequency is determined by loop filter settings.

² Includes loading the configuration bits from OTP to registers. This time also applies when changing configuration select.

³ Actual PLL lock time depends on the loop configuration.

⁴ Actual jitter is configuration dependent. These values are representative of what the device can achieve.

⁵ Input doubler off. Maximum input frequency with input doubler on is 160MHz.

Table 9. Test Frequencies for Jitter Measurements

V_{DDx} = 3.3V±5%, 2.5V±5%, 1.8V±5%, T_A = -40°C to +85°C unless stated otherwise

XIN/CLKIN	OUT0	OUT1	OUT2	OUT3	Unit	Notes
50	156.25				MHZ	3,4
	100				MHZ	1,2,3

¹ This configuration is used for 12kHz–20MHz REF phase jitter measurement, SSC off.

² This configuration is used for PCIe filtered phase jitter measurements with SSC on and off.

³ Outputs configured as LP-HCSL or LVDS with REF output off, unless noted.

⁴ This configuration is used for 12kHz–20MHz OUT phase jitter measurement. REF off, SSC off.

Table 10. LVCMOS Output Electrical Characteristics

Parameter	Symbol	Conditions	Minimum	Typical	Maximum	Unit	Notes
Slew Rate	S _R	3.3V ±5%, 20% to 80% of V _{DDO} (output load = 4.7pF).	2.6	3.7	4.7	V/ns	-
		2.5V ±5%, 20% to 80% of V _{DDO} (output load = 4.7pF).	1.5	2.4	4.7		-
		1.8V ±5%, 20% to 80% of V _{DDO} (output load = 4.7pF).	1.0	1.7	3.2		-
Output High Voltage	V _{OH}	I _{OH} = -15mA at 3.3V.	0.8 x V _{DDO}	-	V _{DDO}	V	-
		I _{OH} = -12mA at 2.5V.					-
		I _{OH} = -8mA at 1.8V.					-

Table 10. LVCMOS Output Electrical Characteristics (Cont.)

Parameter	Symbol	Conditions	Minimum	Typical	Maximum	Unit	Notes
Output Low Voltage	V_{OL}	$I_{OL} = 15\text{mA}$ at 3.3V.	-	0.22	0.4	V	-
		$I_{OL} = 12\text{mA}$ at 2.5V.					-
		$I_{OL} = 8\text{mA}$ at 1.8V.					-
Output Leakage Current	I_{OZDD}	Outputs, tri-stated, $V_{DDO}, V_{DDREF} = 3.465\text{V}$.	-	0	5	μA	-
CMOS Output Driver Impedance	R_{OUT}	$T_A = 25^\circ\text{C}$.	-	17	-	Ω	-

Table 11. LVDS Output Electrical Characteristics

Parameter	Symbol	Minimum	Typical	Maximum	Unit	Notes
Differential Output Voltage for the TRUE Binary State	$V_{OT (+)}$	247	328	454	mV	-
Differential Output Voltage for the FALSE Binary State	$V_{OT (-)}$	-454	-332	-247	mV	-
Change in V_{OT} between Complementary Output States	ΔV_{OT}	-	-	50	mV	-
Output Common Mode Voltage (Offset Voltage) at 3.3V +5% and 2.5V +5%	V_{OS}	1.125	1.19	1.55	V	-
Output Common Mode Voltage (Offset Voltage) at 1.8V +5%	V_{OS}	0.8	0.86	0.95	V	-
Change in V_{OS} between Complementary Output States	ΔV_{OS}	-	0	50	mV	-
Outputs Short Circuit Current, V_{OUT+} or $V_{OUT-} = 0\text{V}$ or V_{DD}	I_{OS}	-	6	12	mA	-
Differential Outputs Short Circuit Current, $V_{OUT+} = V_{OUT-}$	I_{OSD}	-	3	12	mA	-
Rise Times Tested at 20%–80%	T_R	-	257	375	ps	-
Fall Times Tested at 80%–20%	T_F	-	287	375	ps	-

Table 12. Low-Power (LP) Push-Pull HCSL Differential Outputs

$V_{DDO} = 3.3V \pm 5\%$, $2.5V \pm 5\%$, $1.8V \pm 5\%$, $T_A = -40^\circ C$ to $+85^\circ C$ unless stated otherwise.

Parameter	Symbol	Conditions	Minimum	Typical	Maximum	Unit	Notes
Slew Rate	$T_{R/F}$	Scope averaging on.	1.25	2.5	4	V/ns	2,3,16
Slew Rate Matching	$\Delta T_{R/F}$		-	9	20	%	1,14,16
Crossing Voltage (abs)	V_{CROSS}	Scope averaging off.	250	424	550	mV	1,4,5,16
Crossing Voltage (var)	ΔV_{CROSS}	Scope averaging off.		16	140	mV	1,4,9,16
Average Clock Period Accuracy	T_{PERIOD_AVG}	Outputs set to 100MHz for PCIe applications.	-100	0	+2600	-	2,10,12,13
Absolute Period	T_{PERIOD_ABS}	Includes jitter and spread modulation.	9.949	10	10.101	-	2,6
Absolute Maximum Voltage	V_{MAX}	Includes 300mV of overshoot (Vovs).	660	808	1150	mV	1,7,15
Absolute Minimum Voltage	V_{MIN}	Includes -300mV of undershoot (Vuds).	-300	-54	150	mV	1,8,15

¹ Measured from single-ended waveform.

² Measured from differential waveform.

³ Measured from -150mV to +150mV on the differential waveform (derived from REFCLK+ minus REFCLK-). The signal must be monotonic through the measurement region for rise and fall time. The 300mV measurement window is centered on the differential zero crossing.

⁴ Measured at crossing point where the instantaneous voltage value of the rising edge of REFCLK+ equals the falling edge of REFCLK-.

⁵ Refers to the total variation from the lowest crossing point to the highest, regardless of which edge is crossing. Refers to all crossing points for this measurement.

⁶ Defined as the absolute minimum or maximum instantaneous period. This includes cycle to cycle jitter, relative ppm tolerance, and spread spectrum modulation.

⁷ Defined as the maximum instantaneous voltage including overshoot.

⁸ Defined as the minimum instantaneous voltage including undershoot.

⁹ Defined as the total variation of all crossing voltages of rising REFCLK+ and falling REFCLK-. This is the maximum allowed variance in V_{CROSS} for any particular system.

¹⁰ Refer to Section 8.6 of the PCI Express Base Specification, Revision 4.0 for information regarding PPM considerations.

¹¹ System board compliance measurements must use the test load. REFCLK+ and REFCLK- are to be measured at the load capacitors CL. Single ended probes must be used for measurements requiring single ended measurements. Either single ended probes with math or differential probe can be used for differential measurements. Test load $C_L = 2pF$.

¹² PCIe Gen1 through Gen4 specify $\pm 300ppm$ frequency tolerances. The PhiClock devices already meet the tighter $\pm 100ppm$ frequency tolerances proposed for PCIe Gen5 and required by most servers.

¹³ "ppm" refers to parts per million and is a DC absolute period accuracy specification. 1ppm is 1/1,000,000th of 100.000000MHz exactly or 100Hz. For 100ppm, then we have an error budget of $100Hz/ppm \times 100ppm = 10kHz$. The period is to be measured with a frequency counter with measurement window set to 100ms or greater. The $\pm 100ppm$ applies to systems that do not employ Spread Spectrum clocking, or that use common clock source. For systems employing Spread Spectrum Clocking, there is an additional 2,500ppm nominal shift in maximum period resulting from the 0.5% down spread resulting in a maximum average period specification of +2,600ppm for Common Clock architectures. Separate Reference Clock architectures may have a lower allowed spread percentage.

¹⁴ Matching applies to rising edge rate for REFCLK+ and falling edge rate for REFCLK-. It is measured using a $\pm 75mV$ window centered on the median cross point where REFCLK+ rising meets REFCLK- falling. The median cross point is used to calculate the voltage thresholds the oscilloscope is to use for the edge rate calculations. The rise edge rate of REFCLK+ should be compared to the fall edge rate of REFCLK-; the maximum allowed difference should not exceed 20% of the slowest edge rate.

¹⁵ At default amplitude settings.

¹⁶ Guaranteed by design and characterization.

Table 13. PCIe Refclk Phase Jitter - 3.3V Operation

T_{AMB} = over the specified operating range. Supply Voltages = 3.3V ± 5%; see [Test Loads](#) for loading conditions.

Parameter	Symbol	Conditions	Typical	Maximum	Specification Limits	Unit	Notes
PCIe Gen1 (2.5 GT/s)	t _{jph} PCIeG1-CC	Common Clocked Architecture SSC = 0.0% (off)	2767	9218	86,000	fs pk-pk	1, 2, 8
PCIe Gen2 Hi-Band (5.0 GT/s)	t _{jph} PCIeG2-CC		141	433	3,000	fs RMS	1, 2, 8
PCIe Gen2 Lo-Band (5.0 GT/s)			44	79	3,100	fs RMS	1, 2, 8
PCIe Gen3 (8.0 GT/s)	t _{jph} PCIeG3-CC		77	263	1,000	fs RMS	1, 2, 8
PCIe Gen4 (16.0 GT/s)	t _{jph} PCIeG4-CC		77	263	500	fs RMS	1, 2, 3, 4, 8
PCIe Gen5 (32.0 GT/s)	t _{jph} PCIeG5-CC		32	113	150	fs RMS	1, 2, 3, 5, 8
PCIe Gen6 (64.0 GT/s)	t _{jph} PCIeG6-CC		18	61	100	fs RMS	1, 2, 3, 6, 8
PCIe Gen1 (2.5 GT/s)	t _{jph} PCIeG1-CC	Common Clocked Architecture SSC = -0.3% or -0.5%.	5044	11196	86,000	fs pk-pk	1, 2, 8
PCIe Gen2 Hi-Band (5.0 GT/s)	t _{jph} PCIeG2-CC		183	376	3,000	fs RMS	1, 2, 8
PCIe Gen2 Lo-Band (5.0 GT/s)			175	431	3,100	fs RMS	1, 2, 8
PCIe Gen3 (8.0 GT/s)	t _{jph} PCIeG3-CC		112	225	1,000	fs RMS	1, 2, 8
PCIe Gen4 (16.0 GT/s)	t _{jph} PCIeG4-CC		112	225	500	fs RMS	1, 2, 3, 4, 8
PCIe Gen5 (32.0 GT/s)	t _{jph} PCIeG5-CC		41	90	150	fs RMS	1, 2, 3, 5, 8
PCIe Gen6 (64.0 GT/s)	t _{jph} PCIeG6-CC		25	50	100	fs RMS	1, 2, 3, 6, 8
PCIe Gen2 IR (5.0 GT/s)	t _{jph} PCIeG2-IR	IR (SRNS) Architecture SSC = 0%	163	358	N/A	fs RMS	1, 2, 7, 8
PCIe Gen3 IR (8.0 GT/s)	t _{jph} PCIeG3-IR		49	106		fs RMS	1, 2, 7, 8
PCIe Gen4 IR (16.0 GT/s)	t _{jph} PCIeG4-IR		51	107		fs RMS	1, 2, 7, 8
PCIe Gen5 IR (32.0 GT/s)	t _{jph} PCIeG5-IR		47	151		fs RMS	1, 2, 7, 8
PCIe Gen6 IR (64.0 GT/s)	t _{jph} PCIeG6-IR		N/A	N/A		fs RMS	1, 2, 7, 8
PCIe Gen2 IR (5.0 GT/s)	t _{jph} PCIeG2-IR	IR (SRIS) Architecture SSC = -0.1%, -0.3% or -0.5%.	931	1465	N/A	fs RMS	1, 2, 7, 8
PCIe Gen3 IR (8.0 GT/s)	t _{jph} PCIeG3-IR		363	559		fs RMS	1, 2, 7, 8
PCIe Gen4 IR (16.0 GT/s)	t _{jph} PCIeG4-IR		271	483		fs RMS	1, 2, 7, 8
PCIe Gen5 IR (32.0 GT/s)	t _{jph} PCIeG5-IR	IR (SRIS) Architecture	95	159	N/A	fs RMS	1, 2, 7, 8
PCIe Gen6 IR (64.0 GT/s)	t _{jph} PCIeG6-IR	SSC = -0.1% or -0.3%	N/A	N/A		fs RMS	1, 2, 7, 8

¹ The REFCLK jitter is measured after applying the filter functions found in PCI Express Base Specification 6.0, Revision 1.0. See the [Test Loads](#) section of the data sheet for the exact measurement setup. The worst case results for each data rate are summarized in this table. Equipment noise is removed from all measurements.

² Jitter measurements shall be made with a capture of at least 100,000 clock cycles captured by a real-time oscilloscope (RTO) with a sample rate of 20 GS/s or greater. Broadband oscilloscope noise must be minimized in the measurement. The measured PP jitter is used (no extrapolation) for RTO measurements. Alternately, jitter measurements may be used with a Phase Noise Analyzer (PNA) extending (flat) and integrating and folding the frequency content up to an offset from the carrier frequency of at least 200MHz (at 300MHz absolute frequency) below the Nyquist frequency. For PNA measurements for the 2.5 GT/s data rate, the RMS jitter is converted to peak to peak jitter using a multiplication factor of 8.83. In the case where real-time oscilloscope and PNA measurements have both been done and produce different results, the RTO result must be used.

³ SSC spurs from the fundamental and harmonics are removed up to a cutoff frequency of 2MHz taking care to minimize removal of any non-SSC content.

⁴ Note that 700fs RMS is to be used in channel simulations to account for additional noise in a real system.

- ⁵ Note that 250fs RMS is to be used in channel simulations to account for additional noise in a real system.
- ⁶ Note that 150fs RMS is to be used in channel simulations to account for additional noise in a real system.
- ⁷ While the PCI Express Base Specification 6.0, Revision 1.0 provides the filters necessary to calculate IR jitter values, it does not provide specification limits, hence the N/A in the Limit column. IR values are informative only. IR is not defined for PCIe Gen1.
- ⁸ 9FGV1002C or 9FGV1006C with 001, 015, Q505 or Q515 configurations. See the [9FGV1002C/9FGV1006C Standard Configurations](#) table for details and a selection of off-the-shelf configurations supporting PCIe Gen6.

Table 14. PCIe Refclk Phase Jitter - 1.8V Operation

T_{AMB} = over the specified operating range. Supply Voltages = 1.8V ± 5%; see [Test Loads](#) for loading conditions.

Parameter	Symbol	Conditions	Typical	Maximum	Specification Limits	Unit	Notes
PCIe Gen1 (2.5 GT/s)	t _{jph} PCIeG1-CC	Common Clocked Architecture SSC = 0.0% (off)	3186	7259	86,000	fs pk-pk	1, 2, 8
PCIe Gen2 Hi-Band (5.0 GT/s)	t _{jph} PCIeG2-CC		172	341	3,000	fs RMS	1, 2, 8
PCIe Gen2 Lo-Band (5.0 GT/s)			54	93	3,100	fs RMS	1, 2, 8
PCIe Gen3 (8.0 GT/s)	t _{jph} PCIeG3-CC		90	205	1,000	fs RMS	1, 2, 8
PCIe Gen4 (16.0 GT/s)	t _{jph} PCIeG4-CC		90	205	500	fs RMS	1, 2, 3, 4, 8
PCIe Gen5 (32.0 GT/s)	t _{jph} PCIeG5-CC		37	88	150	fs RMS	1, 2, 3, 5, 8
PCIe Gen6 (64.0 GT/s)	t _{jph} PCIeG6-CC		21	47	100	fs RMS	1, 2, 3, 6, 8
PCIe Gen1 (2.5 GT/s)	t _{jph} PCIeG1-CC	Common Clocked Architecture SSC = -0.3% or -0.5%.	5314	14409	86,000	fs pk-pk	1, 2, 8
PCIe Gen2 Hi-Band (5.0 GT/s)	t _{jph} PCIeG2-CC		208	397	3,000	fs RMS	1, 2, 8
PCIe Gen2 Lo-Band (5.0 GT/s)			183	551	3,100	fs RMS	1, 2, 8
PCIe Gen3 (8.0 GT/s)	t _{jph} PCIeG3-CC		119	281	1,000	fs RMS	1, 2, 8
PCIe Gen4 (16.0 GT/s)	t _{jph} PCIeG4-CC		119	281	500	fs RMS	1, 2, 3, 4, 8
PCIe Gen5 (32.0 GT/s)	t _{jph} PCIeG5-CC		44	95	150	fs RMS	1, 2, 3, 5, 8
PCIe Gen6 (64.0 GT/s)	t _{jph} PCIeG6-CC		27	60	100	fs RMS	1, 2, 3, 6, 8
PCIe Gen2 IR (5.0 GT/s)	t _{jph} PCIeG2-IR	IR (SRNS) Architecture SSC = 0%	209	340	N/A	fs RMS	1, 2, 7, 8
PCIe Gen3 IR (8.0 GT/s)	t _{jph} PCIeG3-IR		60	95		fs RMS	1, 2, 7, 8
PCIe Gen4 IR (16.0 GT/s)	t _{jph} PCIeG4-IR		62	97		fs RMS	1, 2, 7, 8
PCIe Gen5 IR (32.0 GT/s)	t _{jph} PCIeG5-IR		55	117		fs RMS	1, 2, 7, 8
PCIe Gen6 IR (64.0 GT/s)	t _{jph} PCIeG6-IR		N/A	N/A		fs RMS	1, 2, 7, 8
PCIe Gen2 IR (5.0 GT/s)	t _{jph} PCIeG2-IR	IR (SRIS) Architecture SSC = -0.1%, -0.3% or -0.5%.	950	1583	N/A	fs RMS	1, 2, 7, 8
PCIe Gen3 IR (8.0 GT/s)	t _{jph} PCIeG3-IR		370	589		fs RMS	1, 2, 7, 8
PCIe Gen4 IR (16.0 GT/s)	t _{jph} PCIeG4-IR		279	602		fs RMS	1, 2, 7, 8
PCIe Gen5 IR (32.0 GT/s)	t _{jph} PCIeG5-IR	IR (SRIS) Architecture	N/A	N/A	N/A	fs RMS	1, 2, 7, 8
PCIe Gen6 IR (64.0 GT/s)	t _{jph} PCIeG6-IR	SSC = -0.1% or -0.3%	N/A	N/A		fs RMS	1, 2, 7, 8

¹ The REFCLK jitter is measured after applying the filter functions found in PCI Express Base Specification 6.0, Revision 1.0. See the [Test Loads](#) section of the data sheet for the exact measurement setup. The worst case results for each data rate are summarized in this table. Equipment noise is removed from all measurements.

- ² Jitter measurements shall be made with a capture of at least 100,000 clock cycles captured by a real-time oscilloscope (RTO) with a sample rate of 20 GS/s or greater. Broadband oscilloscope noise must be minimized in the measurement. The measured PP jitter is used (no extrapolation) for RTO measurements. Alternately, jitter measurements may be used with a Phase Noise Analyzer (PNA) extending (flat) and integrating and folding the frequency content up to an offset from the carrier frequency of at least 200MHz (at 300MHz absolute frequency) below the Nyquist frequency. For PNA measurements for the 2.5 GT/s data rate, the RMS jitter is converted to peak to peak jitter using a multiplication factor of 8.83. In the case where real-time oscilloscope and PNA measurements have both been done and produce different results, the RTO result must be used.
- ³ SSC spurs from the fundamental and harmonics are removed up to a cutoff frequency of 2MHz taking care to minimize removal of any non-SSC content.
- ⁴ Note that 700fs RMS is to be used in channel simulations to account for additional noise in a real system.
- ⁵ Note that 250fs RMS is to be used in channel simulations to account for additional noise in a real system.
- ⁶ Note that 150fs RMS is to be used in channel simulations to account for additional noise in a real system.
- ⁷ While the PCI Express Base Specification 6.0, Revision 1.0 provides the filters necessary to calculate IR jitter values, it does not provide specification limits, hence the N/A in the Limit column. IR values are informative only. IR is not defined for PCIe Gen1.
- ⁸ 9FGV1002C or 9FGV1006C with 002 or Q506 configurations. See the [9FGV1002C/9FGV1006C Standard Configurations](#) table for details and a selection of off-the-shelf configurations supporting PCIe Gen6.

Table 15. 9FGV1002C Current Consumption

$V_{DDO} = 3.3V \pm 5\%$, $2.5V \pm 5\%$, $1.8V \pm 5\%$, $T_A = -40^\circ C$ to $+85^\circ C$ unless stated otherwise.

Parameter	Symbol	Conditions	Minimum	Typical	Maximum	Unit	Notes
V_{DDREF} Supply Current	I_{DDREF}	50MHz REFCL, subtract 3mA for 25MHz REFCLK.	-	7	11	mA	-
Core Supply Current	I_{DDCORE}	2400MHz VCO.	-	37	49	mA	3
Output Buffer Supply Current V_{DDO3}	I_{DDOx}	LVDS, 325MHz.	-	7	9	mA	2
		LP-HCSL, 100MHz.	-	6	7	mA	2
		LVC MOS, 50MHz.	-	4	6	mA	1,2
		LVC MOS, 200MHz.	-	12	21	mA	1,2
Output Buffer Supply Current V_{DDO2} (includes output divider)		LVDS, 325MHz.	-	19	24	mA	2
		LP-HCSL, 100MHz.	-	16	20	mA	2
		LVC MOS, 50MHz.	-	14	18	mA	1,2
		LVC MOS, 200MHz.	-	23	35	mA	1,2
Output Buffer Supply Current V_{DDO1} (this pin must be connected if OUT0 is used)		LVDS, 325MHz.	-	7	10	mA	2
		LP-HCSL, 100MHz.	-	7	10	mA	2
		LVC MOS, 50MHz.	-	8	14	mA	1,2
		LVC MOS, 200MHz.	-	9	15	mA	1,2
Output Buffer Supply Current V_{DDO0}	LVDS, 325MHz.	-	6	9	mA	2	
	LP-HCSL, 100MHz.	-	5	7	mA	2	
	LVC MOS, 50MHz.	-	3	6	mA	1,2	
	LVC MOS, 200MHz.	-	12	22	mA	1,2	
Total Power Down Current	I_{DDPD}	Programmable outputs in HCSL mode, B37[0] = 0.	-	20	27	mA	2
		Programmable outputs in LVDS mode, B37[0] = 0.	-	33	45	mA	2
		Programmable outputs in LVC MOS1 mode, B37[0] = 0.	-	16	22	mA	2

¹ Single CMOS driver active for each output pair.

² See [Test Loads](#) for details.

³ $I_{DDCORE} = I_{DDA} + I_{DD}$. For integer, fractional or spread spectrum PLL.

Table 16. 9FGV1006C Current Consumption

$V_{DDO} = 3.3V \pm 5\%$, $2.5V \pm 5\%$, $1.8V \pm 5\%$, $T_A = -40^\circ C$ to $+85^\circ C$ unless stated otherwise.

Parameter	Symbol	Conditions	Minimum	Typical	Maximum	Unit	Notes
V_{DDREF} Supply Current	I_{DDREF}	50MHz REFCLK.	-	3	7	mA	-
Core Supply Current	I_{DDCORE}	2400MHz VCO.	-	37	48	mA	3
Output Buffer Supply Current (V_{DDO1})	I_{DDOx}	LVDS, 350MHz.	-	19	24	mA	2
		LP-HCSL, 100MHz.	-	16	20	mA	2
		LVC MOS, 50MHz.	-	14	19	mA	1,2
		LVC MOS, 200MHz.	-	22	34	mA	1,2
Output Buffer Supply Current (V_{DDO0} – the total for pins 9 and 10)	I_{DDOx}	LVDS, 350MHz.	-	7	11	mA	2
		LP-HCSL, 100MHz.	-	8	10	mA	2
		LVC MOS, 50MHz.	-	8	13	mA	1,2
		LVC MOS, 200MHz.	-	8	14	mA	1,2
Total Power Down Current	I_{DDPD}	Programmable outputs in HCSL mode, B37[0] = 0.	-	19	25	mA	2
		Programmable outputs in LVDS mode, B37[0] = 0.	-	25	34	mA	2
		Programmable outputs in LVC MOS1 mode, B37[0] = 0.	-	16	22	mA	2

¹ Single CMOS driver active for each output pair.

² See [Test Loads](#) for details.

³ $I_{DDCORE} = I_{DDA} + I_{DDD} + I_{DDAO}$.

Table 17. Spread Spectrum Generation Specifications

Parameter	Symbol	Conditions	Minimum	Typical	Maximum	Unit
Mod Frequency	$f_{MODPCle}$	PCle Compliant -0.5% spread modulation.	30	31.5	33	kHz
Mod Frequency	f_{MOD}	Modulation frequency.	30	31.5	63	kHz
Spread%	SSC%	Amount of spread value (programmable) – down spread.	-0.1	-0.5	-3.0	%
		Amount of spread value (programmable) – center spread.	± 0.05	-	± 1.5	

I²C Bus Characteristics

Table 18. I²C Bus DC Characteristics

Parameter	Symbol	Conditions	Minimum	Typical	Maximum	Unit
Input High Level	V _{IH}	-	0.7 × V _{DDD}	-	-	V
Input Low Level	V _{IL}	-		-	0.3 × V _{DDD}	V
Hysteresis of Inputs	V _{HYS}	-	0.05 × V _{DDD}	-	-	V
Input Leakage Current	I _{IN}	-	-1	-	30	μA
Output Low Voltage	V _{OL}	I _{OL} = 3mA.	-	-	0.4	V

Table 19. I²C Bus AC Characteristics

Parameter	Symbol	Conditions	Minimum	Typical	Maximum	Unit
Serial Clock Frequency (SCL)	F _{SCLK}	-	10	-	400	kHz
Bus free time between STOP and START	t _{BUF}	-	1.3	-	-	μs
Setup Time, START	t _{SU:START}	-	0.6	-	-	μs
Hold Time, START	t _{HD:START}	-	0.6	-	-	μs
Setup Time, Data Input (SDA)	t _{SU:DATA}	-	0.1	-	-	μs
Hold Time, Data Input (SDA) 1	t _{HD:DATA}	-	0	-	-	μs
Output Data Valid from Clock	t _{OVD}	-	-	-	0.9	μs
Capacitive Load for Each Bus Line	C _B	-	-	-	400	pF
Rise Time, Data and Clock (SDA, SCL)	t _R	-	20 + 0.1 × C _B	-	300	ns
Fall Time, Data and Clock (SDA, SCL)	t _F	-	20 + 0.1 × C _B	-	300	ns
HIGH Time, Clock (SCL)	t _{HIGH}	-	0.6	-	-	μs
LOW Time, Clock (SCL)	t _{LOW}	-	1.3	-	-	μs
Setup Time, STOP	t _{SU:STOP}	-	0.6	-	-	μs

Note: A device must internally provide a hold time of at least 300ns for the SDA signal (referred to the V_{IH(MIN)} of the SCL signal) to bridge the undefined region of the falling edge of SCL.

Test Loads

Figure 5. LVCMOS AC/DC Test Load

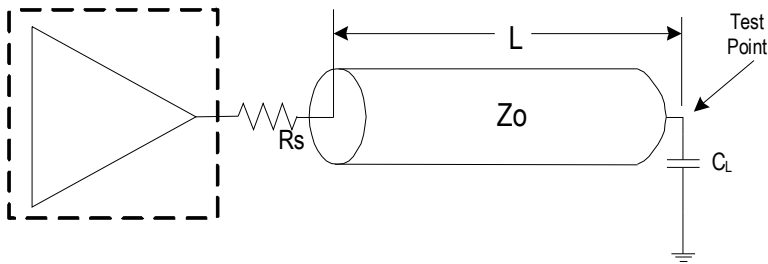

R_s	Z_o	L	C_L
33Ω	50Ω	5 inches	4.7pF

Figure 6. LP-HCSL AC/DC Test Load

(Standard PCIe source-terminated test load)

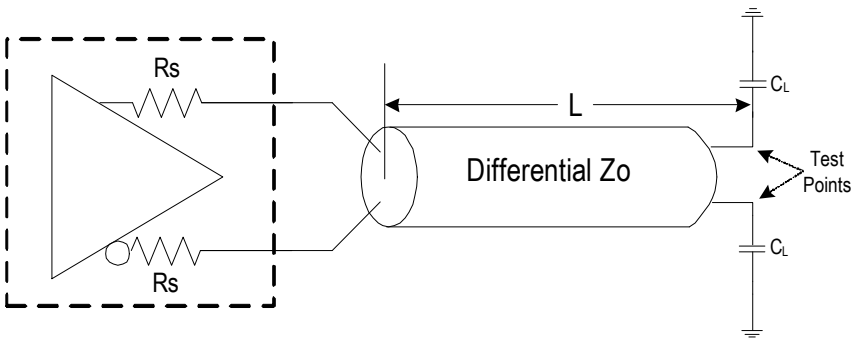

R_s	Z_o	L	C_L
Internal	100Ω	5 inches	2pF
Internal	85Ω	5 inches	2pF

Figure 7. LVDS AC/DC Test Load

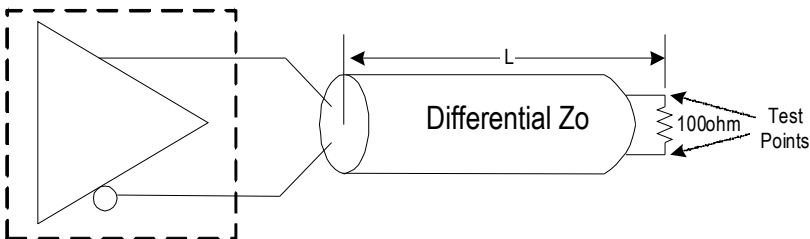

R_s	Z_o	L	C_L
N/A	100Ω	5 inches	N/A

Figure 8. Test Setup for PCIe Measurement Using a Real-Time Scope

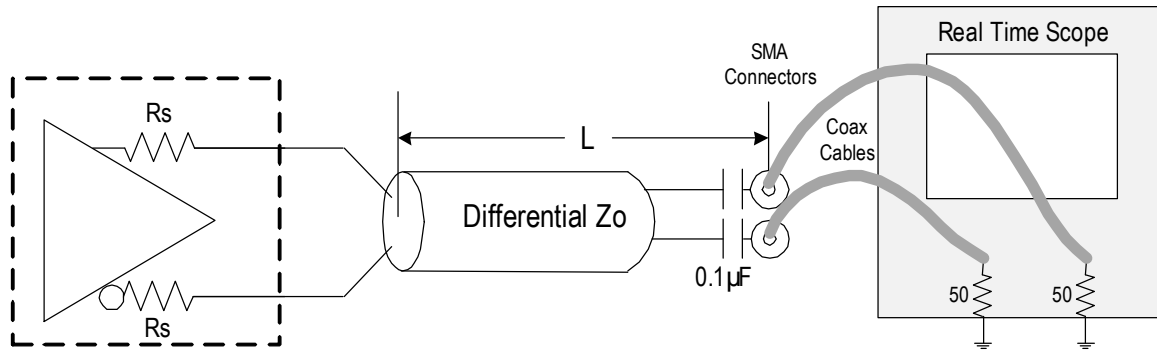

Rs	Zo	L	CL
Internal	100Ω	5 inches	N/A

Figure 9. Test Setup for PCIe Measurement Using a Phase Noise Analyzer

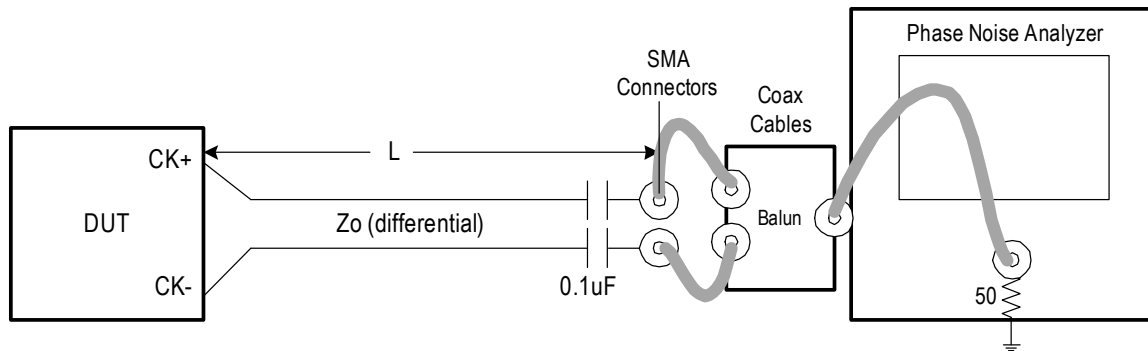

Rs	Zo	L	CL
Internal	100Ω	5 inches	N/A

Crystal Characteristics

Table 20. Recommended Crystal Characteristics

Parameter	Value	Unit
Frequency	8–50	MHz
Resonance Mode	Fundamental	-
Frequency Tolerance at 25°C	±20	ppm maximum
Frequency Stability, REF at 25°C Over Operating Temperature Range	±20	ppm maximum
Temperature Range (commercial)	0 to +70	°C
Temperature Range (industrial)	-40 to +85	°C
Equivalent Series Resistance (ESR)	50	Ω maximum
Shunt Capacitance (C _O)	7	pF maximum
Load Capacitance (C _L)	8	pF maximum
Drive Level	0.1	mW maximum
Aging Per Year	±5	ppm maximum

Package Outline Drawings

The package outline drawings are located at the end of this document and are accessible from the Renesas website (see [Ordering Information](#) for POD links). The package information is the most current data available and is subject to change without revision of this document.

Marking Diagrams

Figure 10. 9FGV1002C Marking Diagrams

<p>9FGV100 2CnnnGI #YWW**\$</p>	<p>1002C Q5aal YWW**\$</p>	<ul style="list-style-type: none"> ▪ Lines 1 and 2 are the truncated part number: <ul style="list-style-type: none"> • “nnn” denotes the decimal digits indicating a specific configuration. • “aa” denotes the alphanumeric digits indicating a specific Q5 configuration. ▪ Line 3: <ul style="list-style-type: none"> • “#” denotes the stepping number. • “YWW” denotes the last digits of the year and week the part was assembled. • “***” denotes the lot sequence; “\$” denotes the mark code.
-----------------------------------------	------------------------------------	---------------------------------------------------------------------------------------------------------------------------------------------------------------------------------------------------------------------------------------------------------------------------------------------------------------------------------------------------------------------------------------------------------------------------------------------------------------------------------------------------------------------------------------------------------------------------------------------------------------------------------------------------

Figure 11. 9FGV1006C Marking Diagrams

<p>6Cnnn YWW\$ XXX</p>	<p>6CQ5aa YWW\$ XXX</p>	<ul style="list-style-type: none"> ▪ Line 1: truncated part number <ul style="list-style-type: none"> • “nnn” denotes the decimal digits indicating a specific configuration. • “aa” denotes the alphanumeric digits indicating a specific Q5 configuration. ▪ Line 2: “YWW” denotes the last digits of the year and week the part was assembled; “\$” denotes mark code. ▪ Line 3: “XXX” denotes the last three characters of the lot number.
--------------------------------	---------------------------------	--------------------------------------------------------------------------------------------------------------------------------------------------------------------------------------------------------------------------------------------------------------------------------------------------------------------------------------------------------------------------------------------------------------------------------------------------------------------------------------------------------------------------------------

Standard Configurations

Table 21. 9FGV1002C/9FGV1006C Standard Configurations

Supply Voltage—all pins (V)	Output Impedance (ohms)	Number of PCIe Clock Outputs	XTAL Frequency (MHz)	Orderable Part Number (Bulk)	Orderable Part Number (Tape and Reel)
3.3	100	4	25 – external	9FGV1002C001NBGI	9FGV1002C001NBGI8
			50 – internal	9FGV1002CQ505LTGI	9FGV1002CQ505LTGI8
		2	25 – external	9FGV1006C001LTGI	9FGV1006C001LTGI8
			50 – internal	9FGV1006CQ505LTGI	9FGV1006CQ505LTGI8
	85	4	25 – external	9FGV1002C015NBGI	9FGV1002C015NBGI8
			50 – internal	9FGV1002CQ515LTGI	9FGV1002CQ515LTGI8
		2	25 – external	9FGV1006C015LTGI	9FGV1006C015LTGI8
			50 – internal	9FGV1006CQ515LTGI	9FGV1006CQ515LTGI8
1.8	100	4	25 – external	9FGV1002C002NBGI	9FGV1002C002NBGI8
			50 – internal	9FGV1002CQ506LTGI	9FGV1002CQ506LTGI8
		2	25 – external	9FGV1006C002LTGI	9FGV1006C002LTGI8
			50 – internal	9FGV1006CQ506LTGI	9FGV1006CQ506LTGI8

Table 22. Common Features of 9FGV1002C/9FGV1006C Standard Configurations

Output Freq (MHz)	Output Type	REF Outputs	Configuration	SSC amount (%)	CC	SRNS, SRIS
100	LP-HCSL	Off	0	0	PCIe Gen1-6	PCIe Gen1-6
			1	-0.1	PCIe Gen1-6	PCIe Gen1-6
			2	-0.3	PCIe Gen1-6	PCIe Gen1-6
			3	-0.5	PCIe Gen1-6	PCIe Gen1-4

Ordering Information

Orderable Part Number	Package	Carrier Type	Temperature	Crystal
9FGV1002CnnnNBGI	4 × 4 mm, 0.5mm pitch 24-VFQFPN	Tray	-40 to +85°C	External
9FGV1002CnnnNBGI8	4 × 4 mm, 0.5mm pitch 24-VFQFPN	Tape and Reel	-40 to +85°C	External
9FGV1002CQ5aaLTGI	4 × 4 mm, 0.5mm pitch 24-LGA	Tray	-40 to +85°C	50MHz Internal
9FGV1002CQ5aaLTGI8	4 × 4 mm, 0.5mm pitch 24-LGA	Tape and Reel	-40 to +85°C	50MHz Internal
9FGV1006CnnnLTGI	3 × 3 mm, 0.5mm pitch 16-LGA	Tray	-40 to +85°C	External
9FGV1006CnnnLTGI8	3 × 3 mm, 0.5mm pitch 16-LGA	Tape and Reel	-40 to +85°C	External
9FGV1006CQ5aaLTGI	3 × 3 mm, 0.5mm pitch 16-LGA	Tray	-40 to +85°C	50MHz Internal
9FGV1006CQ5aaLTGI8	3 × 3 mm, 0.5mm pitch 16-LGA	Tape and Reel	-40 to +85°C	50MHz Internal

“G” indicates RoHS 6.6 compliance.

“nnn” are decimal digits indicating a specific configuration.

“aa” are alphanumeric digits indicating a specific configuration.

“Q5” indicates internal 50MHz crystal.

Revision History

Revision Date	Description of Change
March 29, 2023	Updated footnote 2 in Table 8 .
March 23, 2022	<ul style="list-style-type: none"> ▪ Separated PCIe Refclk Jitter table into separate 3.3V and 1.8V tables (Table 13 and Table 14). ▪ Updated both tables to show PCIe Gen6 support. ▪ Minor updates to front page text.
January 24, 2022	<ul style="list-style-type: none"> ▪ Typo correction: changed unit specification in Key Specifications from 276ps to 276fs. ▪ Updated Package Outline Drawings section; moved package drawing links to Ordering Information.
November 30, 2020	Removed “Output Frequency” parameter from Spread Spectrum Generation Specifications table.
October 29, 2020	Updated pin descriptions for VDDAp and VDDDp.
October 9, 2020	Added a condition and values for REF outputs to the Lock Time parameter.
September 28, 2020	Removed “PCIe Gen5” from the standard configuration tables titles and the relative heading title.
August 18, 2020	Updated 9FGV1006CQ marking diagram.
August 14, 2020	Updated Slew Rate 1.8V minimum value from 0.8 to 1.0V/ns.
August 13, 2020	Updated Carrier Type in Ordering Information table from “Cut-Tape” to “Tray”.
July 16, 2020	Corrected internal resistors on SEL0/SCL and SEL1/SDA to be pull-downs.
July 10, 2020	Initial release.

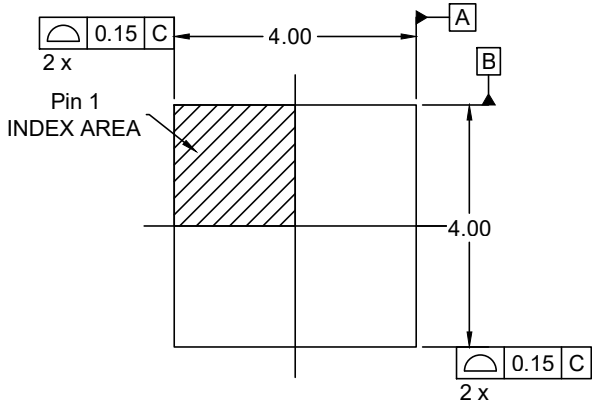

TOP VIEW

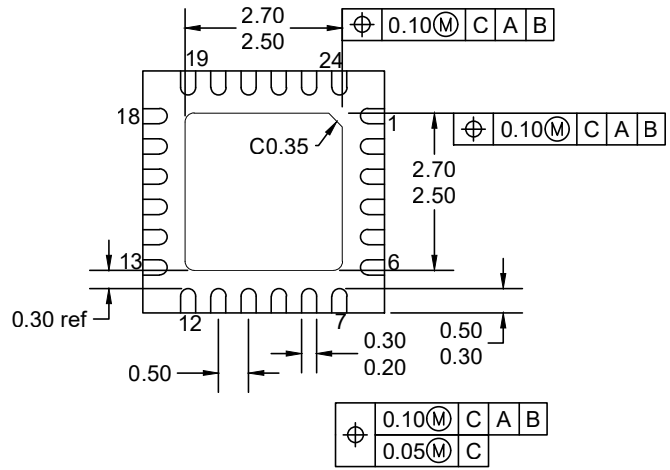

BOTTOM VIEW

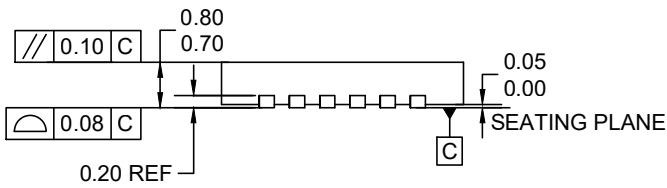

SIDE VIEW

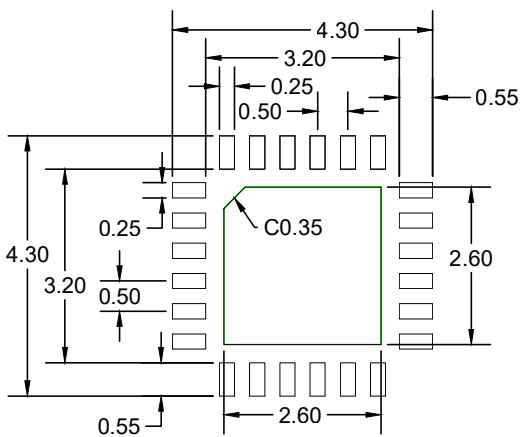

RECOMMENDED LAND PATTERN
(PCB Top View, NSMD Design)

NOTES:

1. JEDEC compatibles.
2. All dimensions are in mm and angles are in degrees.
3. Use ± 0.05 mm for the non-toleranced dimensions.
4. Numbers in () are for references only.

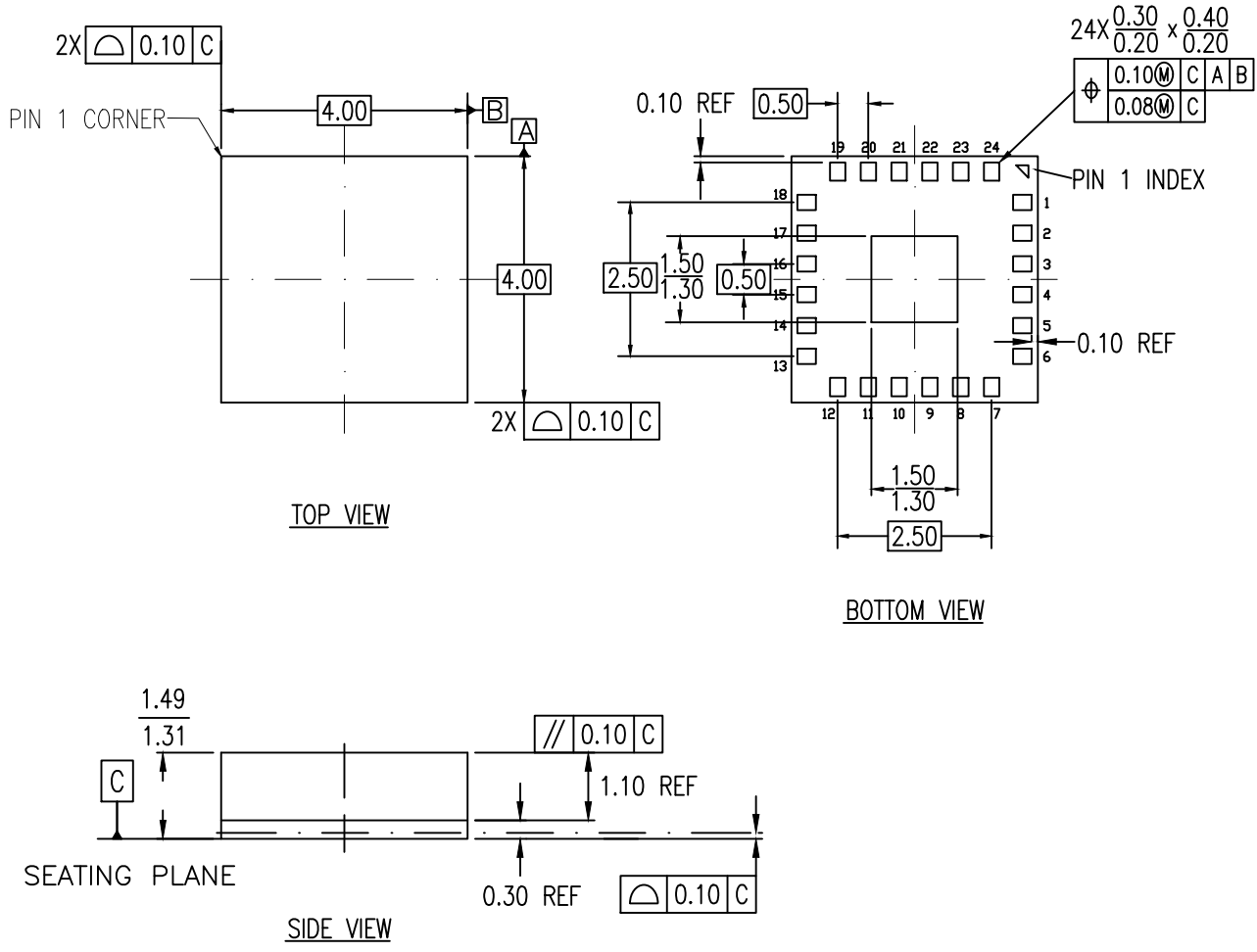

- NOTES:
1. ALL DIMENSIONS ARE IN MILLIMETERS.
 2. DIMENSIONING AND TOLERANCING PER ASME Y14.5M 1994.

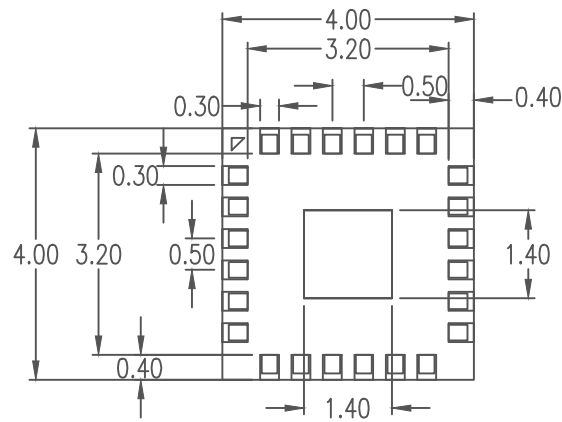

RECOMMENDED LAND PATTERN DIMENSION

NOTES:

1. ALL DIMENSION ARE IN mm. ANGLES IN DEGREES.
2. TOP DOWN VIEW. AS VIEWED ON PCB.
3. LAND PATTERN RECOMMENDATION PER IPC-7351B GENERIC REQUIREMENT FOR SURFACE MOUNT DESIGN AND LAND PATTERN.

Package Revision History		
Date Created	Rev No.	Description
Sept 15, 2017	Rev 00	Initial Release

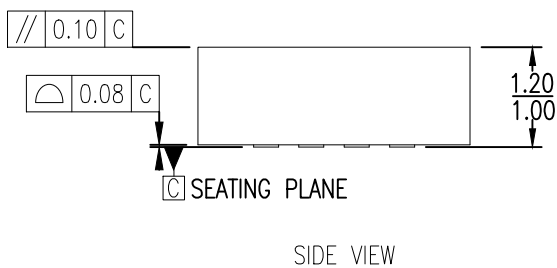
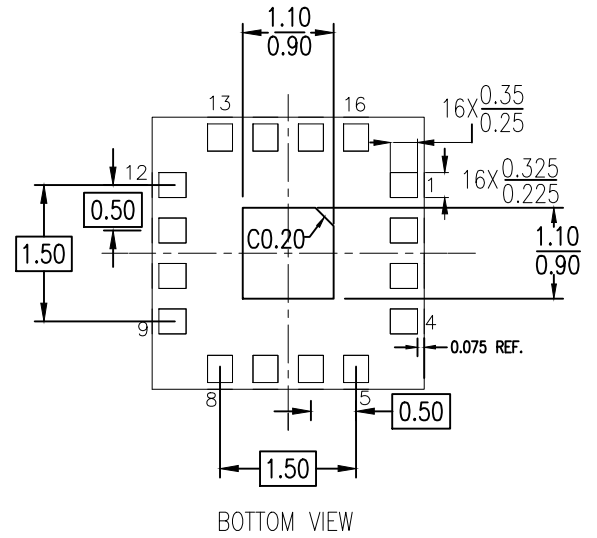
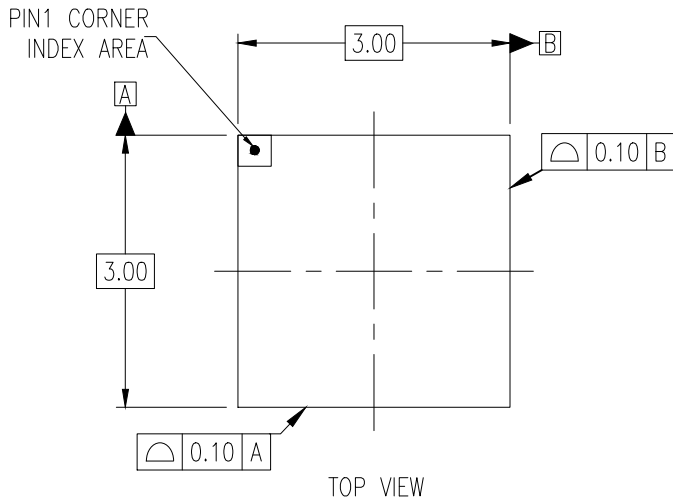

NOTES:

1. ALL DIMENSIONING AND TOLERANCING CONFORM TO ANSI Y14.5M-1982.
2. ALL DIMENSIONS ARE IN MILLIMETERS.

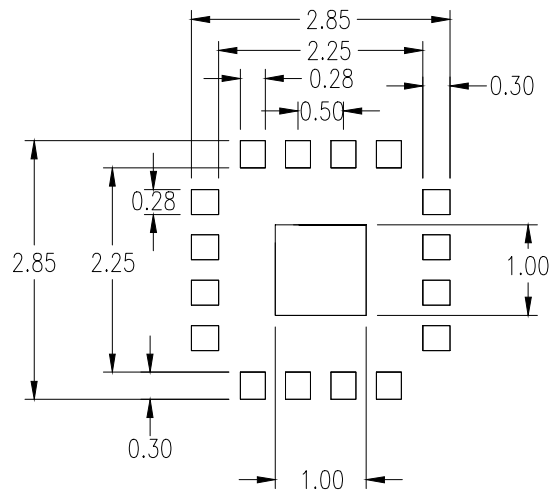

RECOMMENDED LAND PATTERN DIMENSION

NOTES:

1. ALL DIMENSION ARE IN mm. ANGLES IN DEGREES.
2. TOP DOWN VIEW. AS VIEWED ON PCB.
3. LAND PATTERN RECOMMENDATION PER IPC-7351B GENERIC REQUIREMENT FOR SURFACE MOUNT DESIGN AND LAND PATTERN.

IMPORTANT NOTICE AND DISCLAIMER

RENESAS ELECTRONICS CORPORATION AND ITS SUBSIDIARIES (“RENESAS”) PROVIDES TECHNICAL SPECIFICATIONS AND RELIABILITY DATA (INCLUDING DATASHEETS), DESIGN RESOURCES (INCLUDING REFERENCE DESIGNS), APPLICATION OR OTHER DESIGN ADVICE, WEB TOOLS, SAFETY INFORMATION, AND OTHER RESOURCES “AS IS” AND WITH ALL FAULTS, AND DISCLAIMS ALL WARRANTIES, EXPRESS OR IMPLIED, INCLUDING, WITHOUT LIMITATION, ANY IMPLIED WARRANTIES OF MERCHANTABILITY, FITNESS FOR A PARTICULAR PURPOSE, OR NON-INFRINGEMENT OF THIRD PARTY INTELLECTUAL PROPERTY RIGHTS.

These resources are intended for developers skilled in the art designing with Renesas products. You are solely responsible for (1) selecting the appropriate products for your application, (2) designing, validating, and testing your application, and (3) ensuring your application meets applicable standards, and any other safety, security, or other requirements. These resources are subject to change without notice. Renesas grants you permission to use these resources only for development of an application that uses Renesas products. Other reproduction or use of these resources is strictly prohibited. No license is granted to any other Renesas intellectual property or to any third party intellectual property. Renesas disclaims responsibility for, and you will fully indemnify Renesas and its representatives against, any claims, damages, costs, losses, or liabilities arising out of your use of these resources. Renesas' products are provided only subject to Renesas' Terms and Conditions of Sale or other applicable terms agreed to in writing. No use of any Renesas resources expands or otherwise alters any applicable warranties or warranty disclaimers for these products.

(Disclaimer Rev.1.0 Mar 2020)

Corporate Headquarters

TOYOSU FORESIA, 3-2-24 Toyosu,
Koto-ku, Tokyo 135-0061, Japan
www.renesas.com

Contact Information

For further information on a product, technology, the most up-to-date version of a document, or your nearest sales office, please visit:
www.renesas.com/contact/

Trademarks

Renesas and the Renesas logo are trademarks of Renesas Electronics Corporation. All trademarks and registered trademarks are the property of their respective owners.