



Adventurer 3 Pro 2



While preserving the smart and easy-to-use features of the Adventurer 3 series, Adventurer 3 Pro 2 increases the speed to 150mm/s and adopts a new extruder fan structure and a PEI flexible platform design, meeting the needs of individuals, families and educational users with better printing quality and convenient and efficient experience.



Auto leveling



Standard printing speed: 100mm/s;
Max.: 150mm/s



PEI Flexible Build Plate



Detachable Nozzle



Support
PLA/ABS/PETG/
PLA-CF/PETG-CF



150*150*150mm
Build Volume



Filament Detector



Touch Screen
Operation



Cloud Printing
Integrated Management



45 dB
Quiet Printing

Multi-material Printing, Excellent Surface Quality

The new extruder fan structure supports multi-material printing and outputs better quality. The extruder is equipped with three fans and two air guide nozzles, and the dual ducts realize quick cooling of models, offering better surface finish.

240°C, 265°C nozzle supports filaments such as PLA/PETG/PLA-CF/PETG-CF

Detachable nozzle with the snap-on design, replace 3 steps, realizing more worry-free use and maintenance

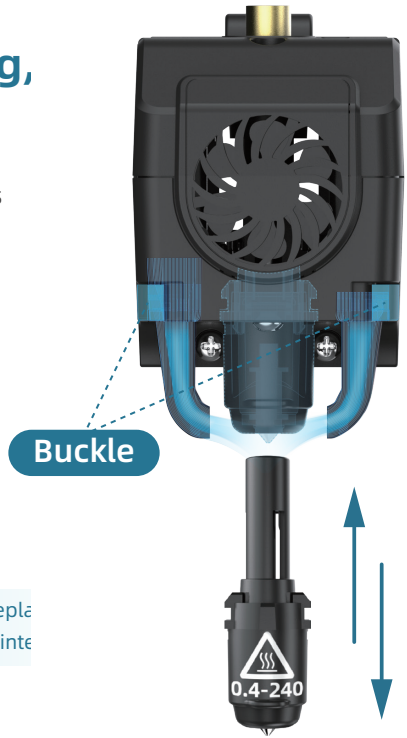

Faster Printing Speed, Less Printing Time

The standard speed of Adventurer 3 Pro 2 is increased from 60mm/s to 100mm/s.



Printing time shortened by **67%**

3DBenchy

60*31*48mm

 **60min**

Adventurer 3 Pro 2

 **1h30min**

Adventurer 3 Pro

Automatic Leveling

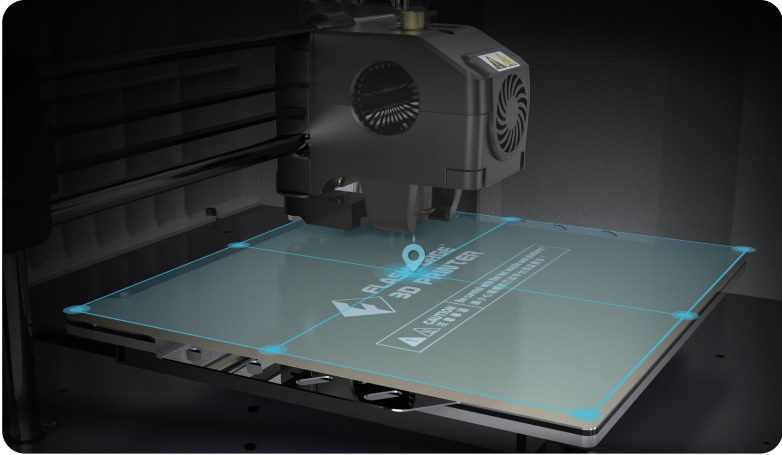

The illustration is for reference only. The actual product shall prevail as actual leveling data collection points may change.

Adventurer 3 Pro 2 adopts multi-point automatic leveling. The relative height between the nozzle and the platform is measured by magnetic induction of the extruder leveling sensor, and then intelligent compensation is carried out during the printing process, which guarantees excellent first-layer printing quality and improves the printing success rate.

PEI Flexible Steel Plate Platform

Adventurer 3 Pro 2's build plate is upgraded with PEI coating to yield smoother model bottom effects;

Magnetic and bendable; models can be easily removed in **1s**, even for large models, no tools required.



PARAMETERS

PRINT

Extruder number:	1
Extruder diameter:	0.4mm(default)/0.6mm(optional)
Highest set temperature of extruder:	265°C
Build volume:	150*150*150mm
Print speed:	0-150mm/s
Highest set temperature of platform:	110°C

DEVICE

Printer volume:	388*340*405mm
Screen:	2.8-inch Touch Screen
Net weight:	9kg
Input:	100-240 VAC, 47-63Hz
Power:	150w
Internal storage:	8G
Spool:	52mm

COMMUNICATION

Data transmission:	USB stick, Wi-Fi, Ethernet, FlashCloud, PolarCloud
Software:	FlashPrint
Output:	GX/G files
Input:	3MF/STL/OBJ/FPP/BMP/PNG/JPG/JPEG files

Zhejiang Flashforge 3D Technology Co., Ltd.

Tel: 400 8866 023 Email: support@flashforge.com
Address: No.518 XianYuan Road, Jinhua City, Zhejiang Province, China

